

# Fisher™ Control-Disk™ NPS 14-36 CL150-300 High-Performance Butterfly Valve

## Contents

Introduction .....	1
Scope of Manual .....	1
Description .....	2
Specifications .....	2
Installation .....	3
Valve Orientation .....	4
Before Installing the Valve .....	4
Adjusting the Actuator Travel .....	6
Installing the Valve .....	7
Packing Adjustment and Shaft Bonding .....	9
Maintenance .....	11
Removing and Replacing the Actuator .....	11
Packing Maintenance .....	11
Removing the Valve .....	13
Seal Maintenance .....	13
PTFE Seals .....	14
NOVEX, Phoenix III and/or Phoenix III Fire-Tested Seals .....	15
Anti-Blowout Design, Packing, Valve Shaft, Disk, and Bearing Maintenance .....	16
Installing the Two-Piece Shaft .....	18
Gasket Retainer .....	20
Parts Ordering .....	20
Parts List .....	22

Figure 1. Fisher Control-Disk Valve with 1061  
Actuator and FIELDVUE™ DVC6020 Digital Valve  
Controller

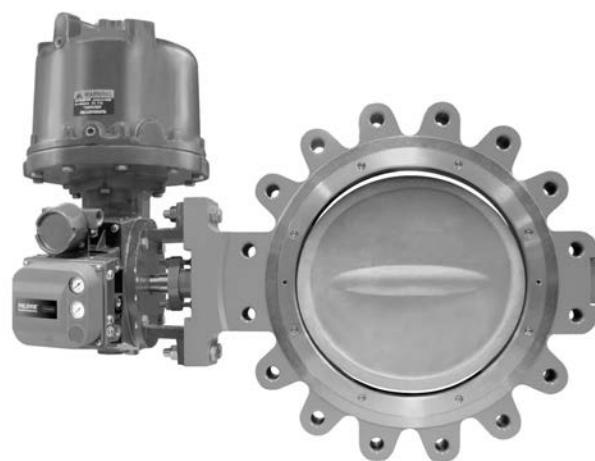

W9138-1

## Introduction

### Scope of Manual

This instruction manual includes installation, maintenance, and parts ordering information for NPS 14 through 36, CL150-300 Control-Disk High-Performance Butterfly Valves (see figure 1). Refer to separate instruction manuals for information covering the actuator and accessories.

Do not install, operate, or maintain Control-Disk valves without being fully trained and qualified in valve, actuator, and accessory installation, operation, and maintenance. To avoid personal injury or property damage, it is important to carefully read, understand, and follow all the contents of this manual, including all safety cautions and warnings. If you have any questions about these instructions, contact your [Emerson sales office](#) or Local Business Partner before proceeding.

Unless otherwise noted, all NACE references are to NACE MR0175-2002.

Table 1. Specifications

<p><b>Valve Size and End Connection Styles</b>            ■ NPS 14, ■ 16, ■ 18, ■ 20, ■ 24, ■ 30, or ■ 36 valves, in ■ wafer-style (flangeless) or ■ single-flange (lugged) with raised-face flanges, CL150 or CL300</p> <p><b>Maximum Pressure Drop<sup>(1)</sup></b>            Consistent with CL150 and CL300 pressure/temperature ratings per ASME B16.34. Contact your <a href="#">Emerson sales office</a> or Local Business Partner for additional information</p> <p><b>Shutoff Classification Per ANSI/FCI 70-2 and IEC 60534-4</b>            Standard Soft Seal: Bidirectional shutoff Class VI (bubble-tight)            NOVEX Seal: Unidirectional shutoff Class V (reverse flow direction only)            Phoenix III Seal: Bidirectional shutoff Class VI (bubble-tight)            Phoenix III Seal for Fire-Tested Applications: Unidirectional shutoff Class VI (reverse flow direction only) (bubble-tight). Fire Tested per API 607 Rev. 4. For cryogenic seal applications, consult your Emerson sales office or Local Business Partner.</p> <p><b>Available Seal Configurations</b>            Standard Constructions            See figure 2 and table 2</p> <p><b>Standard Construction Materials</b>            See table 2</p> <p><b>Flow Characteristic</b>            Equal percentage</p> <p><b>Flow Coefficients</b>            Contact your Emerson Automation Solutions sales office</p>	<p><b>Flow Coefficient Ratio<sup>(2)</sup></b>            100 to 1</p> <p><b>Noise Levels</b>            See Catalog 12 for sound/pressure level prediction</p> <p><b>Valve In-Line Position</b>            Shaft horizontal. See figure 4</p> <p><b>Valve/Actuator Action</b>            With diaphragm or piston rotary actuator, field-reversible between:            ■ push-down-to-close (extending actuator rod closes valve) and            ■ push-down-to-open (extending actuator rod opens valve)</p> <p><b>Valve Body Classification</b>            NPS 14 to 24: Face-to-face dimensions are in compliance with MSS SP68 and API 609 standards. Valve bodies are designed for installation between ASME B16.5 CL150 and CL300 raised-face flanges            NPS 30 to 36: Valve bodies are designed for installation between ASME B16.47 CL150 and CL300 raised-face flanges</p> <p><b>Disk Rotation</b>            Clockwise to close (when viewing from the drive shaft end) through 90 degrees rotation</p> <p><b>Shaft Diameter and Approximate Weight</b>            See tables 3 and 4</p> <p><b>ENVIRO-SEAL™ Packing</b>            This optional packing system provides improved sealing, guiding, and transmission of loading force to control liquid and gas emissions. Contact your Emerson sales office for availability of ENVIRO-SEAL packing</p>
--	---

1. The pressure/temperature limits in this manual, and any applicable code or standard limitation should not be exceeded.  
 2. Ratio of maximum flow coefficient to minimum usable flow coefficient may also be called rangeability.

## Description

The valve is available in either a flangeless wafer body or a single-flange (lugged) body design, with a variety of seals and internal components. The pressure-assisted seal provides tight shutoff. The upper (splined) shaft combines with a variety of pneumatic piston or spring-and-diaphragm actuators. Maximum inlet pressure/temperature ratings are consistent with CL150 and CL300.

Table 2. Material Temperature Ratings

COMPONENT AND MATERIAL OF CONSTRUCTION <sup>(1)</sup>		TEMPERATURE RANGE	
		°C	°F
Body Carbon Steel (WCC or SA 516-70) <sup>(5)</sup> CF8M (316 SST) CL150 CF8M FMS 20B16 (0.04% min carbon) CL300		-29 to 427 -198 to 538 -198 to 816	-20 to 800 -325 to 1000 -325 to 1500
Disk CF8M (316 SST) w/ or w/o Hard coating CF8M with CoCr-A edge (Alloy 6)		-198 to 538 -198 to 538	-325 to 1000 -325 to 1000
Shaft S20910 S17400 (17-4 PH H1025) S17400 (17-4 PH H1150M)		-198 to 538 -73 to 427 -196 to 427	-325 to 1000 -100 to 800 -320 to 800
Bearings PEEK <sup>(2)</sup> (standard) S31600 <sup>(3)</sup>		-73 to 260 -198 to 816	-100 to 500 -325 to 1500
Packing PTFE Packing and PTFE ENVIRO-SEAL Packing Graphite packing Graphite packing with oxidizing media Graphite ENVIRO-SEAL packing		-54 to 232 -198 to 916 -198 to 538 -7 to 316	-65 to 450 -325 to 1500 -325 to 1000 20 to 600
Seal Ring and Backup Ring	PTFE Seal Ring NBR (Nitrile) Backup O-Ring CR (chloroprene) Backup O-Ring EPR Backup O-Ring Fluorocarbon Backup O-Ring PTFE Backup O-Ring	-29 to 93 -43 to 149 -54 to 182 -29 to 204 -73 to 204	-20 to 200 -45 to 300 -65 to 360 -20 to 400 -100 to 400
	UHMWPE <sup>(4)</sup> Seal Ring (CL150 Only) NBR Backup O-Ring CR Backup O-Ring EPR Backup O-Ring Fluorocarbon Backup O-Ring PTFE Backup O-Ring	-29 to 93 -43 to 93 -54 to 93 -29 to 93 -73 to 93	-20 to 200 -45 to 200 -65 to 200 -20 to 200 -100 to 200
	Phoenix III and/or Fire Tested Construction S31600 and PTFE Seal Ring with NBR Backup O-Ring CR Backup O-Ring EPR Backup O-Ring Fluorocarbon Backup O-Ring	-40 to 149 -54 to 149 -62 to 204 -40 to 232	-40 to 300 -65 to 300 -80 to 400 -40 to 450
Seal Ring	NOVEX S31600 Seal <sup>(3)</sup> Ring (CL150) NOVEX S31600 Seal <sup>(3, 6)</sup> Ring (CL300) NOVEX S21800 Seal Ring (CL300)	-29 to 538 -29 to 816 -29 to 816	-20 to 1000 -20 to 1500 -20 to 1500
	Cryogenic Seal Ring	Contact your Emerson sales office	

1. NACE trim constructions are available; consult your [Emerson sales office](#) or Local Business Partner.  
 2. PEEK stands for poly-ether-ether-ketone.  
 3. For a complete material description, contact your Emerson Automation Solutions sales office.  
 4. UHMWPE stands for ultra high molecular weight polyethylene.  
 5. Cast or wrought /plate grades used interchangeably, depending upon availability - unless specified by customer.  
 6. Seal rated for CL150 pressures. For fully rated CL300 seal rating, use NOVEX S21800 seal ring.

## Installation

The valve is normally shipped as part of a control valve assembly, with the power actuator mounted on the valve. If the valve or actuator has been purchased separately, or if the actuator has been removed for maintenance, mount the actuator on the valve, and adjust actuator travel before installing the valve into the line. This is necessary due to the measurements that must be made during the actuator calibration adjustment process. Refer to the Actuator Mounting section of this manual and to the separate actuator instruction manual for mounting and adjusting instructions before proceeding.

### **⚠ WARNING**

To avoid personal injury or property damage resulting from the sudden release of pressure:

- Always wear protective gloves, clothing, and eyewear when performing any maintenance operation.
- Do not install the valve assembly where service conditions could exceed the limits given in this manual or on the nameplates.
- Use pressure-relieving devices as required by government or accepted industry codes and good engineering practices to protect from over-pressurizing the system.
- Check with your process or safety engineer for any other hazards that may be present from exposure to process media.
- If installing into an existing application, also refer to the WARNING at the beginning of the Maintenance section in this instruction manual.

## CAUTION

When ordered, the valve configuration and construction materials were selected to meet particular pressure, temperature, pressure drop, and controlled fluid conditions. Responsibility for the safety of process media and compatibility of valve materials with process media rests solely with the purchaser and end-user. Since some body/trim material combinations are limited in their pressure drop and temperature ranges, do not apply any other conditions to the valve without first contacting your Emerson Automation Solutions sales office.

1. Isolate the control valve from the line pressure, release pressure from both sides of the valve body, and drain the process media from both sides of the valve. If using a power actuator, shut off all pressure lines to the power actuator, release pressure from the actuator, and disconnect the pressure lines from the actuator. Use lock-out procedures to be sure that the above measures stay in effect while you are working on the equipment.

See the WARNING at the beginning of the Maintenance section for more information before removing the valve from the pipeline.

2. Install a three-valve bypass around the control valve assembly if continuous operation is necessary during inspection and maintenance of the valve.
3. Inspect the valve to be certain that it is free of foreign material.
4. Be certain that adjacent pipelines are free of any foreign material, such as pipe scale or welding slag, that could damage the valve sealing surfaces.

## CAUTION

Damage to the disk will occur if any pipe flanges or piping connected to the valve interfere with the disk rotation path. If the piping flange has a smaller inner diameter than specified for schedule 80 piping, measure carefully to be certain the disk rotates without interference before placing the valve into operation. Minimum inside diameters for flanges or pipe mating with valves are shown in tables 3 and 4.

## Valve Orientation

The valve can be installed in any orientation, however it is recommended that the valve drive shaft be horizontal and the actuator vertical as shown in figure 4.

Install the valve with the high-pressure shutoff side in the direction noted by the flow arrow for proper installation, and see figure 4 for more information.

## Before Installing the Valve

### ⚠ WARNING

The edges of a rotating valve disk (key 2, figure 9) close with a shearing, cutting motion. To avoid personal injury, keep hands, tools, and other objects away from the disk while stroking the valve.

If the Control-Disk valve is equipped with a fail-open actuator, cycle the valve into the fully closed position. Ensure the valve cannot open during installation by using a manual actuator, a constant supply pressure to the pneumatic actuator, or other steps as necessary.

Table 3. Valve Body Data, CL150

VALVE SIZE, NPS	SHAFT DIAMETER AT ACTUATOR YOKE	FACE-TO-FACE DIMENSION <sup>(1)</sup>	MINIMUM I.D. <sup>(2)</sup>	APPROXIMATE WEIGHT, KILOGRAMS	
				Wafer	Single-Flange
mm					
14	31.8	92.1	331.2	79.8	103
16	31.8	102	375.2	106	150
18	39.7	114	418.8	152	191
20	44.5	127	464.1	191	248
24	57.2	154	580.9	286	381
30	(3)	159	723.9	625	824
36	(3)	178	876.3	934	1250
VALVE SIZE, NPS	SHAFT DIAMETER AT ACTUATOR YOKE	FACE-TO-FACE DIMENSION <sup>(1)</sup>	MINIMUM I.D. <sup>(2)</sup>	APPROXIMATE WEIGHT, POUNDS	
				Wafer	Single-Flange
Inches					
14	1.25	3.63	13.04	176	227
16	1.25	4.00	14.77	233	330
18	1.56	4.50	16.49	336	422
20	1.75	5.00	18.27	421	546
24	2.25	6.06	22.87	630	840
30	(3)	6.25	28.5	1380	1820
36	(3)	7.00	34.5	2060	2750

1. NPS 14 to 24 face-to-face dimensions are in compliance with MSS SP68 and API 609 specifications.  
 2. Minimum I.D. is the minimum pipe or flange I.D. required for disk swing clearance.  
 3. Contact your [Emerson sales office](#) for information.

Table 4. Valve Body Data, CL300

VALVE SIZE, NPS	SHAFT DIAMETER AT ACTUATOR YOKE	FACE-TO-FACE DIMENSION <sup>(1)</sup>	MINIMUM I.D. <sup>(2)</sup>	APPROXIMATE WEIGHT, KILOGRAMS	
				Wafer	Single-Flange
mm					
14	44.5	118	304.3	143	249
16	44.5	133	346.2	203	314
18	57.2	149	389.4	253	427
20	76.2	156	442.0	388	568
24	88.9	181	523.2	501	853
30	(3)	241	670.6	1070	1520
36	(3)	273	828.0	1470	2150
VALVE SIZE, NPS	SHAFT DIAMETER AT ACTUATOR YOKE	FACE-TO-FACE DIMENSION <sup>(1)</sup>	MINIMUM I.D. <sup>(2)</sup>	APPROXIMATE WEIGHT, POUNDS	
				Wafer	Single-Flange
Inches					
14	1.75	4.63	11.98	315	549
16	1.75	5.25	13.63	447	693
18	2.25	5.88	15.32	558	941
20	3.00	6.13	17.40	855	1250
24	3.50	7.13	20.59	1110	1880
30	(3)	9.50	26.4	2360	3360
36	(3)	10.8	32.6	3240	4730

1. Face-to-face dimensions are in compliance with MSS SP68 and API 609 specifications.  
 2. Minimum I.D. is the minimum pipe or flange I.D. required for disk swing clearance.  
 3. Contact your Emerson sales office for information.

A Control-Disk valve is normally shipped as part of an assembly with an actuator and other accessories such as a valve positioner. If the valve and actuator have been purchased separately or if the actuator has been removed for maintenance, properly mount the actuator and adjust valve/actuator travel before inserting the valve into the line.

## CAUTION

Damage to the disk will occur if any pipe flanges or piping connected to the valve interfere with the disk rotation path. Be certain to align the valve accurately to avoid contact between the disk (key 2) and the flanges.

Figure 2. Available Seal Configurations

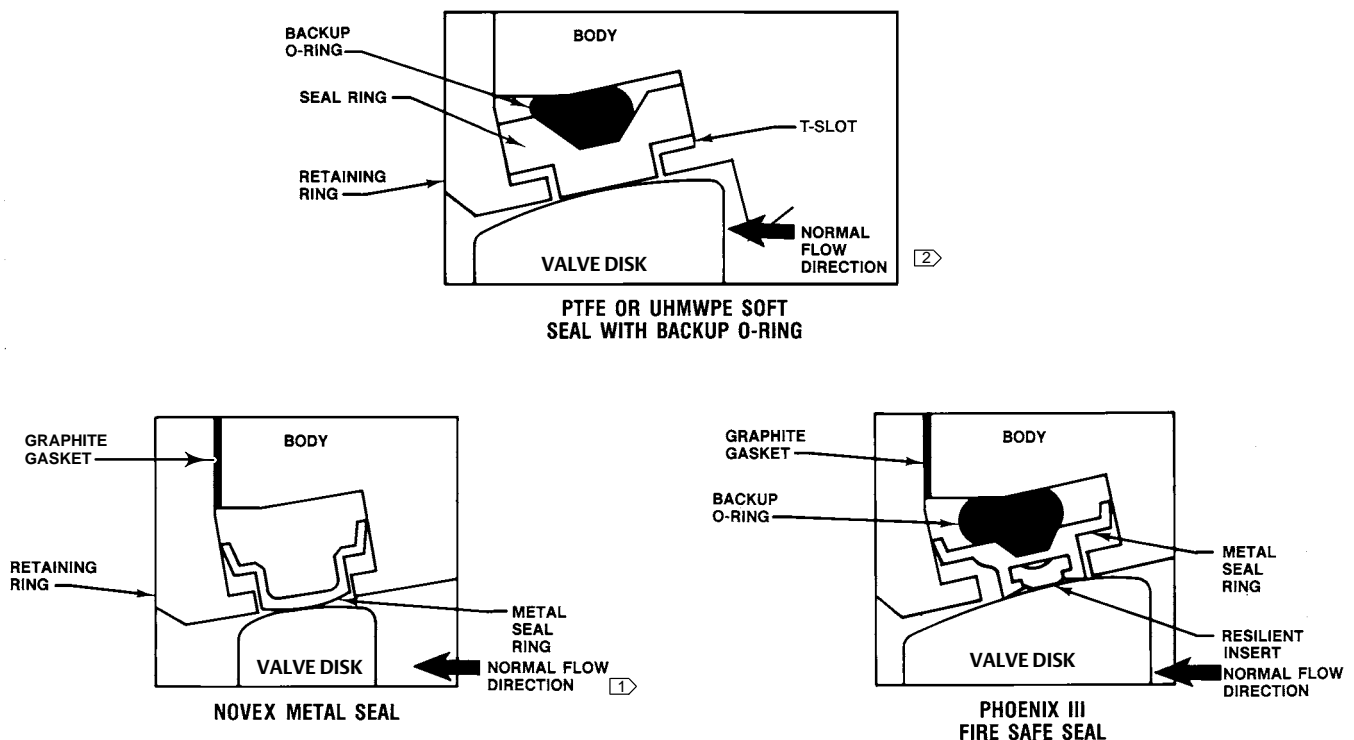

B2313-3

NOTES:

① THIS UNIDIRECTIONAL SEAL MUST BE INSTALLED SO THAT THE RETAINING RING IS DOWNSTREAM FROM THE HIGH PRESSURE SIDE OF THE VALVE AT SHUTOFF, AS SHOWN.

② FOR THIS BIDIRECTIONAL SEAL, THE "PREFERRED" VALVE ORIENTATION PLACES THE RETAINING RING DOWNSTREAM FROM THE HIGH PRESSURE SIDE OF THE VALVE AT SHUTOFF.

## Adjusting the Actuator Travel

Key number locations are shown in figure 9, unless otherwise noted.

1. Adjust the actuator to bring the disk to the fully closed position at the end of the actuator stroke. To determine the fully closed disk position, measure the distances between the disk face and the seal retainer face at the top and bottom of the valve (X1 and X2) as shown in figure 3. Adjust the actuator to rotate the disk slightly until the two measurements are within 0.8 mm (0.032 inch) of each other. Refer to the appropriate actuator instruction manual for assistance.
2. Before installing the valve/actuator assembly in the process line, cycle the valve several times to be sure the valve disk returns to the proper position.

Figure 3. Sectional of Typical Valve Body

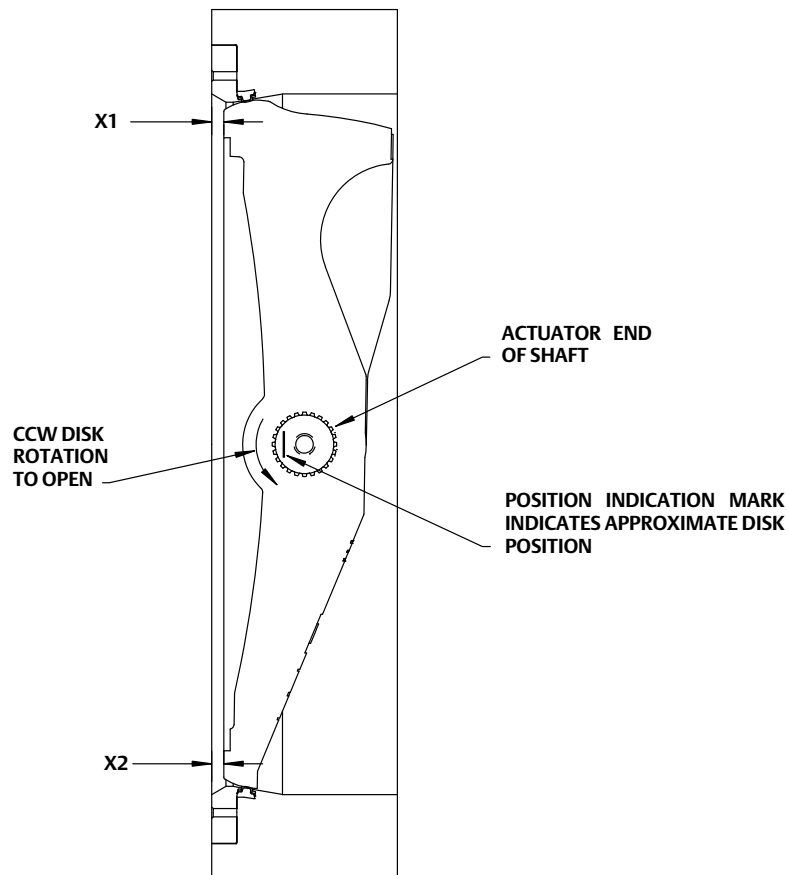

GE53027-A

## Installing the Valve

The maximum allowable inlet pressures for Control-Disk valves are consistent with the applicable ASME pressure/temperature ratings except where limited by the material capabilities as shown in table 2 or figure 2.

Refer to table 5 for the quantity and size of line bolting required to install the valve in the pipeline.

### CAUTION

To avoid damage to the valve disk during installation, the valve must be in the fully closed position. If the Control-Disk valve is equipped with a fail-open actuator, remove the actuator before installing the valve/actuator assembly or cycle the valve into the fully closed position. Then, take appropriate steps to be sure that the actuator does not cause the valve to open during installation.

Table 5. Hex Head Screw, Stud Bolt and Cap Screw Data<sup>(1)</sup>

VALVE SIZE, NPS	NO. OF CAP SCREWS		NO. OF STUD BOLTS		SIZE-DIA. INCH & THREAD		LENGTH OF CAP SCREWS, INCH		LENGTH OF STUD BOLTS, INCH	
	CL150	CL300	CL150	CL300	CL150	CL300	CL150	CL300	CL150	CL300
<b>Single-Flange Style<sup>(2)</sup></b>										
14	24	40	---	---	1-8	1-1/8-8	2.75	3.5	---	---
16	32	40	---	---	1-8	1-1/4-8	3	3.75	---	---
18	32	48	---	---	1-1/8-8	1-1/4-8	3.25	4	---	---
20	40	48	---	---	1-1/8-8	1-1/4-8	3.5	4	---	---
24	40	48	---	---	1-1/4-8	1-1/2-8	3.5	4.5	---	---
30	8	8	24	24	1-1/4-8	1-3/4-8	4.5	5.75	15.5	21.5
36	8	8	28	28	1-1/2-8	2-8	5.25	6.5	18	24.25
<b>Wafer-Style</b>										
14	---	8	12	16	1-8	1-1/8-8	---	3.5	9.5	12
16	---	8	16	16	1-8	1-1/8-8	---	3.75	10	13.5
18	---	8	16	16	1-1/8-8	1-1/4-8	---	4	11	13.75
20	---	8	20	20	1-1/8-8	1-1/4-8	---	4	12	14.5
24	---	8	20	20	1-1/4-8	1-1/2-8	---	4.5	14	16.5
30	56	56	---	---	1-1/4-8	1-3/4-8	4.5	5.75	---	---
36	64	64	---	---	1-1/2-8	2-8	5.25	6.5	---	---

1. Thread engagement in accordance with ASME B31.3 "Chemical Plant and Petroleum Refinery Piping".  
2. Bolting lengths are based on installation of valve between standard raised face flanges and utilizing flange gaskets with a final compression thickness of 0.125 inch. When gaskets used have a final compression thickness of less than 0.125 inch, reduce bolting lengths shown by 0.25 inch.

Figure 4. Installation of Wafer-Style Valves

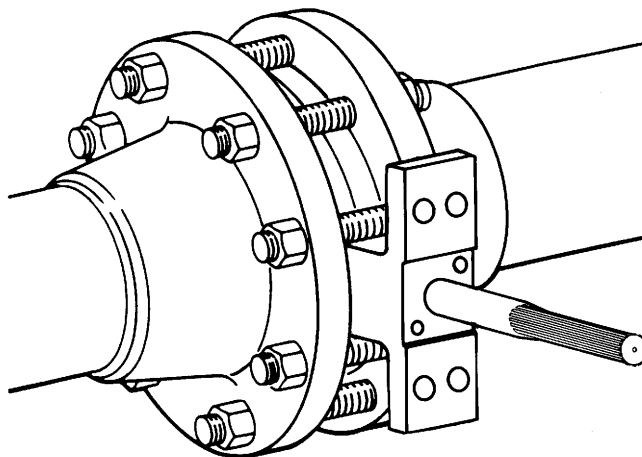

A5557

- See figure 4 for recommended valve orientation.
  - For Wafer-Style Valves: Install the lower flange bolts first to form a cradle for the valve (see figure 5). See table 5 for flange bolt specifications.
  - For Single-Flange Valves: Position the valve between the flanges. Be sure to leave enough room for the flange gaskets. Install the lower flange bolts.
- For all Valves: Select the appropriate gaskets for the application. Flat sheet, spiral wound, or other gasket types, made to the ASME B16.5 standard or user's standard, can be used on Control-Disk valves depending on the service conditions of the application.



Figure 5. Proper Installation Steps

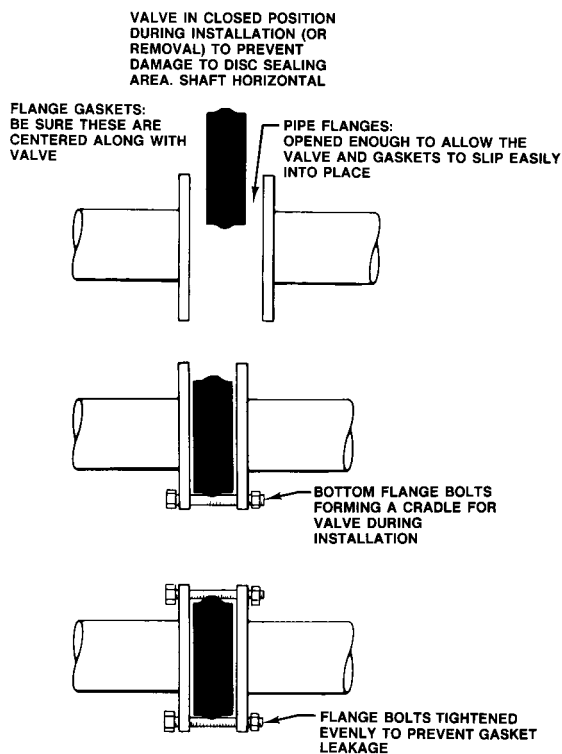

3. For Wafer-Style Valves: Properly orient the valve according to the specific application. Place the valve in the line so the flow properly enters the valve as indicated by the flow tag. Then, install the valve and the gaskets between the flanges into the cradle formed by the flange bolts.
4. Install the remaining flange bolts.
  - For Wafer-Style Valves: Make sure the gaskets are centered on the gasket sealing surfaces of the flange and body.
5. For all Valves: Tighten the flange bolts in an alternating criss-cross fashion to a torque value of one-fourth of the final bolting torque. Repeat this procedure several times, increasing the torque value each time by a fourth of the final desired torque. After applying the final torque value, tighten each flange bolt again to allow for gasket compression.

## Packing Adjustment and Shaft Bonding

### **⚠ WARNING**

Personal injury could result from packing leakage. Valve packing was tightened before shipment; however, the packing might require some readjustment to meet specific service conditions. Check with your process or safety engineer for any other hazards that may be present from exposure to process media.

Figure 6. Optional Shaft-to-Valve Body Bonding Strap Assembly

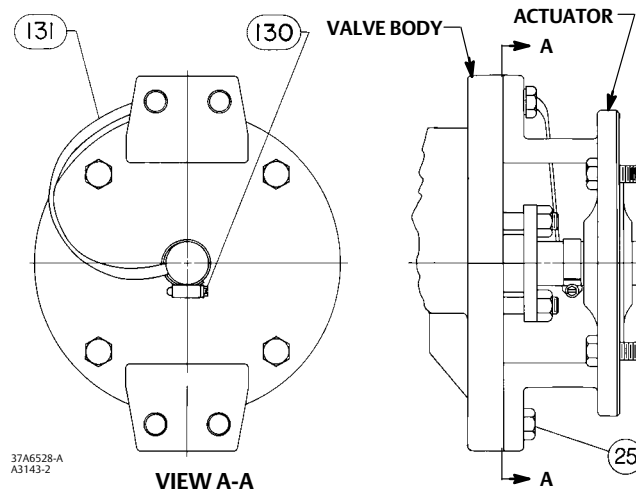
**CAUTION**

**For non-ENVIRO-SEAL packing: Tighten the packing follower nuts only enough to prevent shaft leakage. Excessive tightening will accelerate wear of the packing and could produce higher friction loads on the valve stem.**

1. For PTFE or graphite packing: Tighten standard packing follower nuts only enough to prevent shaft leakage. Excessive tightening of packing will accelerate wear and could produce higher rotating friction loads on the valve stem. If necessary, refer to the Packing Maintenance section.
2. The ENVIRO-SEAL Packing Systems will not require this initial re-adjustment. Refer to the separate instruction manual ENVIRO-SEAL Packing System for Rotary Valves, D101643X012, for repair and adjustment procedures.
3. For hazardous atmosphere or oxygen service valves, read the following Warning, and provide the bonding strap assembly mentioned below if the valve is used in an explosive atmosphere.

**⚠ WARNING**

**The valve shaft is not necessarily grounded when installed in a pipeline unless the shaft is electrically bonded to the valve. To avoid personal injury or property damage resulting from the effects of a static electricity discharge from valve components in a hazardous atmosphere or where the process fluid is combustible, electrically bond the drive shaft (key 3) to the valve according to the following step.**

**Note**

Standard PTFE packing is composed of a partially conductive carbon-filled PTFE female adaptor with PTFE V-ring packing. Standard graphite packing is composed of all conductive graphite ribbon packing. Alternate shaft-to-valve body bonding is available for hazardous service areas where the standard packing is not sufficient to bond the shaft to the valve (see the following step).

For oxygen service applications, provide alternate shaft-to-valve body bonding according to the following step.

4. Attach the bonding strap assembly (key 131, figure 6) to the shaft with the clamp (key 130, figure 6).

5. Connect the other end of the bonding strap assembly to the valve flange cap screws.
6. For more information, refer to the Packing Maintenance section below.

## Maintenance

Valve parts are subject to normal wear and must be inspected and replaced as necessary. The frequency of inspection and replacement depends upon the severity of service conditions.

Key numbers in this procedure are shown in figure 9 unless otherwise indicated.

### **⚠ WARNING**

**Avoid personal injury from sudden release of process pressure. Before performing any maintenance operations:**

- Always wear protective gloves, clothing, and eyewear when performing any maintenance operations to avoid personal injury.
- Disconnect any operating lines providing air pressure, electric power, or a control signal to the actuator. Be sure the actuator cannot suddenly open or close the valve.
- Use bypass valves or completely shut off the process to isolate the valve from process pressure. Relieve process pressure on both sides of the valve. Drain the process media from both sides of the valve.
- Vent the power actuator loading pressure.
- Use lockout procedures to be sure that the above measures stay in effect while you work on the equipment.
- The valve packing box may contain process fluids that are pressurized, *even when the valve has been removed from the pipeline*. Process fluids may spray out under pressure when removing the packing hardware or packing rings, or when loosening the packing box pipe plug.
- Check with your process or safety engineer for any other hazards that may be present from exposure to process media.

## Removing and Replacing the Actuator

Refer to the appropriate actuator instruction manual for actuator removal and replacement procedures.

## Packing Maintenance

The Control-Disk valve is designed so the packing can be replaced without removing the valve from the process pipeline.

### **CAUTION**

**For non-ENVIRO-SEAL packing: Tighten the packing follower nuts only enough to prevent shaft leakage. Excessive tightening will accelerate wear of the packing and could produce higher friction loads on the valve stem.**

Usually, packing leakage can be eliminated by merely tightening the hex nuts (key 15) located above the packing follower (key 11) while the valve is in the pipeline. However, if leakage continues, the packing must be replaced.

For PTFE ENVIRO-SEAL packing systems, refer to the separate instruction manual, ENVIRO-SEAL Packing System for Rotary Valves, [D101643X012](#), (see figure 10).

Figure 7. Anti-Blowout Design Details

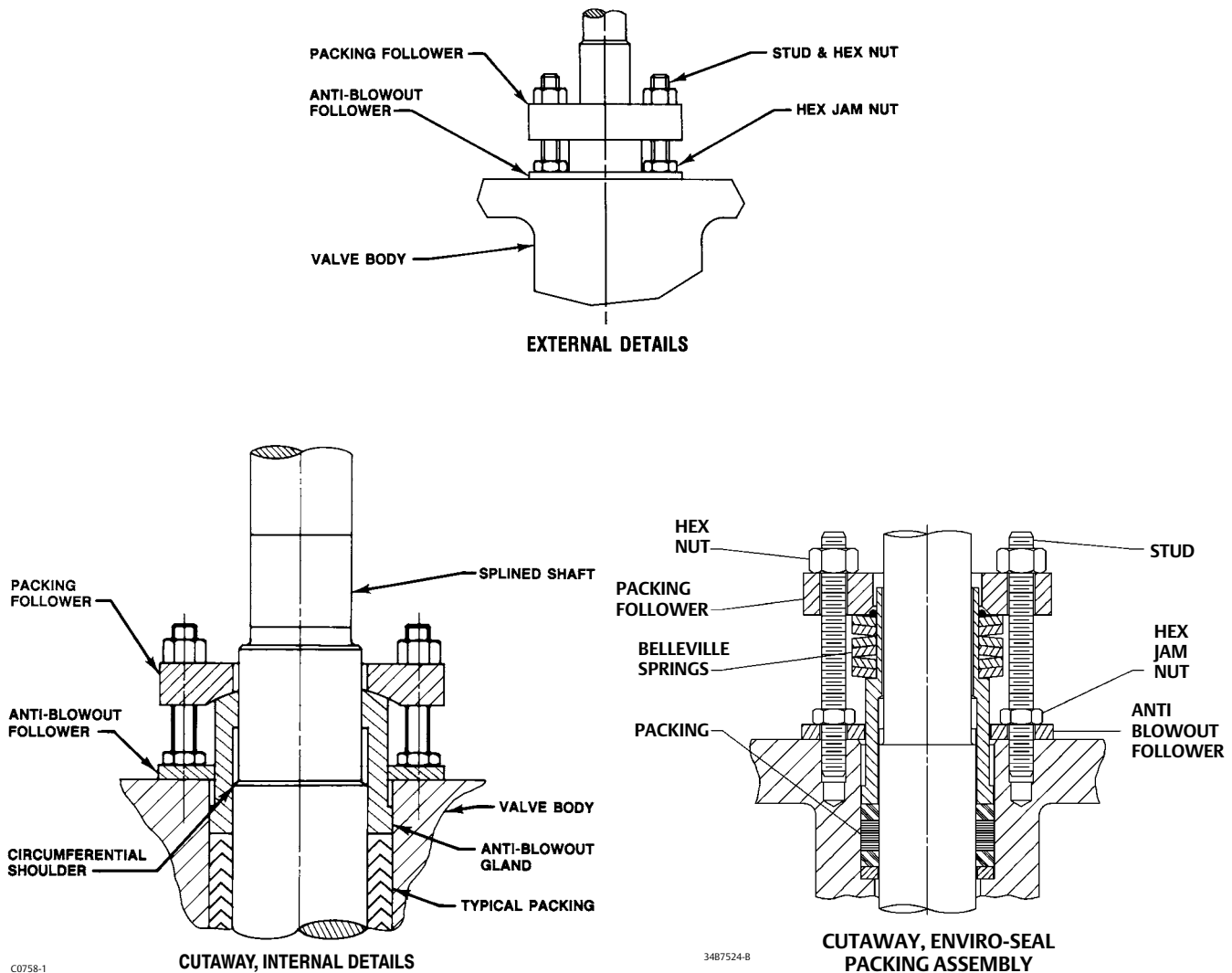
**CAUTION**

Never use a wrench or pliers on the splined (upper) shaft (key 3). A damaged shaft could cut the packing and allow leakage.

1. Before loosening any parts on the valve, release the pressure from the pipeline. Then, remove the hex nuts (key 15) and lift off the packing follower (key 11).
2. Remove the hex jam nuts (key 17) and the anti-blowout flange (key 10). Remove the packing follower (key 12). Refer to figure 7 for details of the anti-blowout design parts.

The packing is now accessible.

3. Use a packing extractor to remove packing. Insert the corkscrew-like end of the tool into the first piece of packing and pull firmly to remove the packing. Repeat this process until all packing parts have been removed.

**CAUTION**

Be careful when cleaning the packing box. Scratches to the upper shaft (key 3) or inside diameter of the packing bore might cause leakage.

4. Before installing new packing, clean the packing box.
5. Install new packing one ring at a time, using the packing follower as a driver. If using split-ring packing, stagger the splits in the rings to avoid creating a leak path.
6. Reinstall packing parts. Refer to figure 9 for sequence of packing parts.

## Removing the Valve

1. Disconnect any operating lines providing air pressure, electric power, or a control signal to the actuator. Be sure the actuator cannot suddenly open the valve. Vent the power actuator loading pressure.
2. Use bypass valves or completely shut off the process to isolate the valve from process pressure. Relieve process pressure on both sides of the valve. Drain the process media from either side of the valve.

**CAUTION**

Damage to the valve disk can occur if the disk is not closed when the valve is being removed from the pipeline. If necessary, stroke the actuator to place the disk in the closed position while removing the valve from the pipeline.

3. Loosen the flange bolting that holds the valve. Make sure the valve cannot slip or twist while loosening and removing the bolting.
4. Before removing the valve from the pipeline, make sure the valve disk is closed. Removing the valve with the disk open could cause damage to the disk, piping, or pipe flanges.
5. After removing the valve from the pipeline, move the valve to an appropriate work area. Always support the valve properly.
6. When valve maintenance is complete, refer to the Installation procedures in this manual.

## Seal Maintenance

**Note**

For larger valves, it is possible to replace the seal (key 5) while the actuator is mounted to the valve and can be accomplished by cycling the valve to 90 degrees open.

Key numbers in this procedure are shown in figure 9 unless otherwise indicated.

1. After removing the valve from the pipeline, remove the manual or power actuator. Manually rotate the upper shaft (key 3) counterclockwise until the disk has moved a full 180 degrees away from the closed position.

**⚠ WARNING**

Avoid personal injury or property damage caused by the impact of a falling or tipping of a large valve. Support large valves during maintenance.

2. Lay the valve flat on a work bench in a secure position with the retaining ring (key 18) and retaining ring screws (key 19) facing up. Properly secure the valve on a suitable worktable so it cannot slip, twist, or fall during maintenance. Remove all retaining ring screws.
3. Remove the retaining ring by placing a socket head cap screw from the retaining ring in each of the two retaining ring jacking screw holes. Slowly turn the screws until the retaining ring has been lifted from the valve body. Remove the retaining ring to expose the seal in the T-slot area of the valve body.

**Note**

The Control-Disk valve is available with different seal designs and components. See figure 2 to identify the specific seal design.

**CAUTION**

In the following procedure, take care not to damage the seal or T-slot area of the valve body during removal of the seal.

4. Insert a regular screwdriver or other similar tool under the top edge of the seal and gently pry the seal out of the T-slot area in the valve body. Take care not to damage the seal or T-slot area of the valve body. After the seal has been removed, clean the T-slot area, retaining ring and, if required, polish the disk (key 2) thoroughly with fine steel wool or other appropriate material.

To install a new seal, O-ring (key 6), and retaining ring gasket, follow the appropriate instructions given below.

Table 6. Torque Values for Fasteners

FASTENER NOMINAL SIZE	RETAINING RING SCREWS		GASKET RETAINING BOLTS	
	N•m	In•lbs	N•m	In•lbs
#10	4.6	41	4.0	35
1/4	11	100	9.2	81
5/16	25	220	19	167
3/8	45	400	33	295
	N•m	ft•lbs	N•m	ft•lbs
7/16	72	53	53	39
1/2	112	83	80	59
9/16	161	119	117	86
5/8	225	166	161	119
3/4	401	296	286	210
7/8	651	480	447	330
1	976	720	651	480
1-1/8	1356	1000	837	617

Note: These values are based upon standard materials, S66286/N07718 screws and ASTM A193GRB6 bolts. For other special fastener materials, please contact your Emerson sales office.

**PTFE Seals**

1. Locate the replacement seal ring (key 5) and note the shape of the ring. The ring is wider across one edge diameter and narrower across the other edge diameter. Around the outside circumference is one wide groove.

Before installing the seal ring into the valve body, place the O-ring (key 6) into the wide, outer groove of the seal ring. Refer to figure 8.

2. Install the seal ring and O-ring assembly in the valve body. The wider outside diameter of the seal ring goes into the T-slot area of the body (see figure 5). Start the edge with the wider diameter into the T-slot of the valve body using a blunt-end screwdriver. If you have a maintenance kit, use the seal installation tools.

Figure 8. Typical Seal Installation

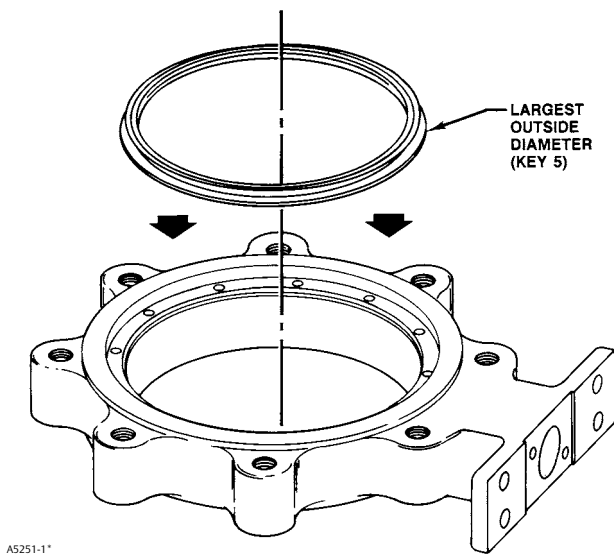

3. Carefully tuck the O-ring downward into the body T-slot until the seal ring is completely entrapped in the body T-slot, and it completely covers the backup O-ring.
4. Re-install the retaining ring and the socket head cap screws. Tighten the cap screws just enough to eliminate any movement of the retaining ring. Do not over-tighten the retaining ring screws. Using a blunt-end tool, carefully tuck the lip of the seal ring under the retaining ring.
5. When the seal is under the lip of the retaining ring, continue to tighten the cap screws according to standard procedures. Do not fully torque the screws at this time. Final tightening of the screws is accomplished in step 7 of this procedure.
6. Manually rotate the upper shaft clockwise 180 degrees to return the disk (key 2) to its closed position.
7. The final seating of the retaining ring cap screws can now be done. For the screw torque values, refer to table 6. The seal is now fully installed. Refer to the Installation procedures in this manual.

### NOVEX, Phoenix III and/or Phoenix III Fire-Tested Seals

1. Locate the replacement seal ring (key 5) and note the shape of the ring. The ring is wider across one edge diameter and narrower across the other edge diameter as shown in figure 8. Around the outside circumference is one wide groove.

Install the seal ring (key 5) in the valve body by first placing the wider outside diameter of the seal ring into the T-slot area of the valve body which is shown in figure 2.

The backup O-ring (key 6) for the Phoenix III seal will have to be installed after placement of the seal ring in the valve body using a blunt-end screwdriver or the seal installation tool in the maintenance kit. Do not use the screwdriver or seal tool directly on the metal seat. Use tools on the O-ring only.

2. With the seal ring inserted all the way around the body T-slot now lay the O-ring into the opening between the valve body and the seal ring. Use the seal tool to apply pressure to the O-ring and carefully tuck the O-ring down into the T-slot between the valve body and the seal ring.

---

**Note**

On larger valves, it may be more efficient to have someone hold down the seal ring while you push the O-ring into the T-slot.

---

3. Once the seal ring and backup O-ring have been fully installed into the body T-slot, the retaining ring gasket can be installed. This gasket is a thin graphite material. Punch one initial screw hole through the gasket for alignment, being careful not to cause additional damage to the gasket.
4. Install the retaining ring and align the screw holes in the retaining ring with the holes in the valve body. Install the first retaining ring screw through the punched hole in the ring gasket. Install the other ring screws by pushing the screws through the graphite gasket and threading them into the valve body.
5. Tighten the retaining ring socket head cap screws just enough to eliminate any movement of the retaining ring. Do not over-tighten the retaining ring screws.

**⚠ WARNING**

**Avoid personal injury or property damage caused by the impact of a falling or tipping of a large valve. Support large valves during maintenance.**

---

6. To complete this step, stand the valve up. Support the valve securely using methods appropriate for the valve size. If a vise or other clamps are being used, be sure to not damage the flange gasket sealing area of the valve body.
7. Manually rotate the upper shaft (key 3) to turn the disk clockwise to meet the seal.
8. Adjust the actuator to bring the disk to the fully closed position at the end of the actuator stroke. To determine the fully closed disk position, measure the distances between the disk face and the seal retainer face at the top and bottom of the valve (X1 and X2) as shown in figure 3. Adjust the actuator to rotate the disk slightly until the two measurements are within 0.8 mm (0.032 inch) of each other. Refer to the appropriate actuator instruction manual for assistance.
9. The final seating of the retaining ring screws can now be done. For the screw torque values, refer to table 6.

## Anti-Blowout Design, Packing, Valve Shaft, Disk, and Bearing Maintenance

---

**Note**

The Control-Disk valve has a two-piece shaft. In these procedures, the shaft (with the splined end) is called the upper shaft (key 3). The shaft opposite the upper shaft is called the lower (follower) shaft (key 4).

---

**CAUTION**

**When removing the actuator from the valve, do not use a hammer or similar tool to drive the lever off the valve shaft. Driving the lever or actuator off the valve shaft could damage the valve internal parts.**



---

**If necessary, use a wheel puller to remove the lever or actuator from the valve shaft. It is okay to tap the wheel puller screw lightly to loosen the lever or actuator, but hitting the screw with excessive force could also damage internal valve parts.**

---

Key numbers in this procedure are shown in figure 9 unless otherwise indicated.

1. Remove the valve from the pipeline. Remove the actuator from the valve.

## CAUTION

**Never use a wrench, pliers, or similar tool to turn the upper shaft. A damaged shaft can cut the packing and allow leakage.**

---

### Note

It is not necessary to remove the retaining ring and valve seal when removing the shaft(s) and disk.

---

## ⚠ WARNING

**Avoid personal injury or property damage caused by the impact of a falling or tipping of a large valve. Support large valves during maintenance.**

---

2. Properly secure the valve on a suitable worktable so it cannot slip, twist, or fall during maintenance.
3. Removing the Anti-Blowout Design:
  - a. **For PTFE or Graphite Packing:** Remove the hex nuts (key 15) and pull off the packing follower (key 11). Remove the hex jam nuts (key 17) and the anti-blowout flange (key 10). Remove the anti-blowout gland (key 12). See figure 7.
  - b. **For ENVIRO-SEAL Packing System:** Remove the hex nuts (key 101), the packing follower (key 102), jam nuts (key 17), anti-blowout flange (key 10), and the spring pack assembly (key 103). See figure 10.
4. Remove the packing from around the upper shaft.
5. Remove the tangential pins or disk pins. Locate the pins (key 9) in the upper shaft (key 3) and the pin in the lower shaft (key 4), if the valve has a two-piece shaft.
  - a. If a maintenance kit is available, use the pin extractor to remove the disk pins. Select the correct size pin extractor tip with screws of proper thread size to match the thread size in the disk pins. If you do not have a kit, see steps c and d below.
  - b. Screw the pin extractor tip into the pin as far as possible. With an upward, straight sliding motion, pull out the pin. Repeat the same procedure for the other pins.
  - c. You can use a threaded rod with an appropriate spacer (tube) and nut as an extractor tool. If you use a threaded rod, choose a rod with threads that fit the inside thread of the pins. The rod should extend several inches above the disk when it is screwed into a pin.
  - d. After screwing the rod into the pin, slide the spacer over the rod and pin. Thread a nut onto the rod and tighten it. As you tighten the nut, the nut will drive the spacer against the disk. The increasing force will draw the pin from the disk.

6. The gasket retainer (key 20) on the side of the valve opposite the upper shaft must be removed before removing the lower shaft.

Remove the hex head bolts (key 23) and lockwashers (key 22) from the gasket retainer and remove the gasket retainer and gasket (key 21) to expose the end of the lower shaft.

7. Before removing the lower shaft (key 4), be sure the valve disk is properly supported. Pull the lower shaft from the valve body. Use a shaft extractor screwed into the puller hole in the end of the lower shaft.
8. Before removing the upper shaft (key 3), be sure the valve disk is properly supported. Pull out the upper shaft (key 3) by hand-pulling or by using a shaft extractor screwed into the end of the shaft.

## CAUTION

**To avoid damage to the disk, seal, and T-slot area, do not force the disk past the seal or T-slot area. Remove the disk from the opposite side of the valve body.**

### Note

Both the upper shaft and the lower shaft have a thrust bearing (key 24) between the disk and the bearings (key 7). The thrust bearing is located outside of the bearing bore which holds the bearings. Use care when removing the valve disk to avoid loss of or damage to the thrust bearings.

9. After removing the shaft(s), remove the disk. Do not force the disk past the seal or T-slot area. Collect the thrust bearings.
10. Remove the bearings (key 7). Using a suitable punch or puller, drive or pull the bearings into the valve body bore from the upper shaft bearing bore. Remove the bearing from the lower shaft bearing bore.
11. Inspect the valve body bore, bearings, bearing bores, and packing box for damage.

### Note

In these instructions, the drive shaft (with splined end) is called the upper shaft (key 3). The shaft opposite the upper shaft is called the lower (follower) shaft (key 4).

## Installing the Two-Piece Shaft

Key numbers in this procedure are shown in figure 9 unless otherwise indicated.

## ⚠ WARNING

**Avoid personal injury or property damage caused by the impact of a falling or tipping of a large valve. Support large valves during maintenance.**

1. Properly secure the valve on a suitable worktable so it cannot slip, twist, or fall during maintenance. Be prepared to support the valve disk.

### Note

Replacement disk and shafts are provided as a matched set and both should be replaced at the same time.

2. Inspect all parts removed from the valve for wear or damage. Replace any worn or damaged parts. Clean the valve body and all parts to be installed with an appropriate solvent or degreaser.

---

**Note**

When installing the bearings, apply lubricant to the outside diameter of the bearing for ease of installation.

---

**CAUTION**

**Premature valve failure and loss of process control may result if bearings are improperly installed or are damaged during installation.**

---

3. When installing the lower bearings (key 4), insert one or more bearings into the lower shaft bearing bore so it is flush with the body bore.

The number of bearings required changes with valve size and construction. Two bearings are required in the upper shaft and two bearings in the lower shaft. If using an NPS 14 CL150 valve with metal bearings, four bearings in the upper and four in the lower shaft will be required.

4. Hold the lower shaft thrust bearing (key 24) in the valve body bore against the counterbore of the lower shaft bearing bore. Push the lower shaft into the bearing bore just enough to hold the thrust bearing.
5. When installing the upper bearing (key 7), insert one or more bearings into the upper shaft from the body bore into the bearing bore below the packing box. Use caution to prevent damage to the bearing.
6. Hold the upper shaft thrust bearing (key 24) in the valve body bore against the counterbore of the upper shaft bearing bore. Push the upper shaft through the packing box side into the bearing bore just enough to hold the thrust bearing.
7. When installing the lower bearing (key 4), insert one or more bearings into the lower shaft bearing bore so it is flush with the body bore.
8. Insert the lower shaft through the bore in the valve body uncovered by removal of the gasket retainer. Hold the lower shaft thrust bearing (key 24) in the valve body bore against the counterbore of the lower shaft bearing bore. Push the lower shaft into the bearing bore just enough to hold the thrust bearing.

**CAUTION**

**To avoid damage to the disk, seal, and T-slot area, do not force the disk past the seal or T-slot area. Install the disk from the opposite side of the valve body.**

---

9. Place the flat side of the disk on a flat surface and insert wooden blocks to raise the disk approximately 51 mm (2 inches) from the worktable surface. Then, suspend the valve body over the disk so the seal/T-slot area is facing up. Align the shaft bores through the disk with the upper shaft and lower shaft bores. Lower the valve body over the disk using caution not to dislodge or damage the thrust bearings placed on the ends of the shafts.
10. With the disk (key 2) properly positioned in the valve body (key 1), push the upper shaft and lower shaft the rest of the way through the thrust bearings and into the shaft bores in the valve disk.
11. Align the holes in the shafts with the holes in the disk.

## CAUTION

**To avoid damage to the tangential pins, disk pins, valve disk, or shaft(s) resulting from the application of excessive force, use appropriate care when driving the pins into the disk hub and shaft(s). Use the right tool. Do not use excessive force.**

12. Install the appropriate tangential pins, and disk pins. Use 2 tangential pins that will go through the upper shaft and 1 disk pin that will go through the lower shaft.
13. Refer to the Anti-Blowout Design, Packing, Valve Shaft, Disk and Bearing Maintenance procedures in this manual to re-install the packing and anti-blowout design.

## Gasket Retainer

Valves with a two-piece shaft use a gasket retainer and gasket (keys 20 and 21) to cover the lower shaft opening in the valve body. The gasket is held in place by the gasket retainer and four hex head bolts and lockwashers (keys 23 and 22). When re-assembling the valve, use a new gasket.

Be sure to center the gasket over the lower shaft bore before retightening bolts. Tighten down bolts evenly in a crossover or star pattern.

Refer to table 6 for proper torque values.

## Parts Ordering

Typical parts are shown in figure 9.

When corresponding with your [Emerson sales office](#) or Local Business Partner about a Control-Disk valve, identify the valve as a Control-Disk and provide the valve serial number. For valve/actuator combinations assembled at the factory, the valve serial number is stamped on the nameplate attached to the actuator.

## ⚠ WARNING

**Use only genuine Fisher replacement parts. Components that are not supplied by Emerson Automation Solutions should not, under any circumstances, be used in any Fisher valve, because they may void your warranty, might adversely affect the performance of the valve, and could cause personal injury and property damage.**

## Retrofit Kits

Retrofit kits include all parts required for installation of the ENVIRO-SEAL packing system into existing high-performance butterfly valves. Retrofit kits are available for single PTFE packing.

See table 7 for retrofit kit part numbers.

Retrofit Kit Included Parts		
Key	Description	Quantity
10	Anti-blowout follower	1
17	Jam nut	1
100	Packing stud	2
101	Packing nut	2
102	Packing flange	1
103	Spring pack assembly	1
105	Packing Set	1
106	Anti-extrusion washer	2 <sup>(1)</sup>
107	Packing box ring	2 <sup>(2)</sup>
111	Tag	1
112	Cable	1

1. Not included in graphite packing kit.  
2. Only 1 req'd for NPS 18 CL300, NPS 20 CL150 and NPS 24 CL150.

Note: Key 103, the spring pack assembly, is made up of the packing spring stack held in place by an O-ring on the packing follower.

## Repair Kits

PTFE Repair kits include a single PTFE packing set and anti-extrusion washers. Graphite packing sets include graphite packing rings and carbon anti-extrusion rings. See table 7 for PTFE repair kit part numbers.

Table 7. Retrofit and Repair Kit Part Numbers

VALVE SIZE, NPS	PRESSURE RATING	SHAFT DIAMETER <sup>(1)(2)</sup> , mm (Inch)	RETROFIT KITS	REPAIR KITS
			PTFE	PTFE
14	CL150	34.9 (1-3/8)	RRTYXRT0592	RRTYX000172
	CL300	50.8 (2)	RRTYXRT0602	RRTYX000182
16	CL150	38.1 (1-1/2)	RRTYXRT0612	RRTYX000192
	CL300	57.2 (2-1/4)	RRTYXRT0622	RRTYX000202
18	CL150	44.5 (1-3/4)	RRTYXRT0632	RRTYX000212
	CL300	63.5 (2-1/2)	RRTYXRT0642	RRTYX000222
20	CL150	50.8 (2)	RRTYXRT0652	RRTYX000182
24	CL150	63.5 (2-1/2)	RRTYXRT0662	RRTYX000222
30, 36	No kit available			

1. Shaft diameter: Diameter through the packing box.  
2. For larger shaft sizes, consult your [Emerson sales office](#) or Local Business Partner.

## Parts List

### Note

Part numbers are shown for recommended spares only. For part numbers not shown, contact your [Emerson sales office](#) or Local Business Partner.

Key	Description	Part Number
	NPS 30	V115138X012
	NPS 36	V115155X012
14	Stud (2 req'd)	
15	Hex nut (2 req'd)	
17	Hex Jam Nut (2 req'd)	
18	Retaining Ring	
19	Retaining Ring Screw	
20	Gasket Retainer	
21*	Gasket (See following table)	
22	Lockwasher (4 req'd)	
23	Cap Screw (4 req'd)	
24*	Thrust Bearing (See following table)	
26*	Retaining Ring Gasket NOVEX and Phoenix III Seal Standard & NACE	
	CL150	
	NPS 14	V161467X012
	NPS 16	V161468X012
	NPS 18	V161469X012
	NPS 20	V112062X012
	NPS 24	V161471X012
	NPS 30	V168292X012
	NPS 36	V124869X012
	CL300	
	NPS 14	V113741X012
	NPS 16	V112064X012
	NPS 18	V161469X012
	NPS 20	V112062X012
	NPS 24	V124867X012
	NPS 30	V124882X012
	NPS 36	V124883X012
	Oxygen Service	
	CL150	
	NPS 14	V161467X022
	NPS 16	V161468X022
	NPS 18	V161469X022
	NPS 20	V169962X012
	NPS 24	V161471X022
	NPS 30	V168292X022
	NPS 36	V124869X022
	CL300	
	NPS 14	V113741X022
	NPS 16	V112064X022
	NPS 18	V161469X022
	NPS 20	V112062X022
	NPS 24	V124687X022
	NPS 30	V124882X022
	NPS 36	V124883X022
27	Cap Screw - Actuator (4 req'd)	
28	Hex Nut - Actuator (4 req'd)	
29	Nameplate (not shown)	
32	Drive Screw (2 req'd) (not shown)	
33	Flow Direction Arrow (not shown)	
34	Packing Box Ring	
35	Disk/Shaft/Pin Assembly	
1	Valve Body If you need a valve body as a replacement part, order the valve size, Class and desired material. Contact your Emerson sales office or Local Business Partner.	
2	Disk	
3	Drive Shaft	
4	Follower Shaft	
5*	Seal Ring (See following table)	
6*	Backup Ring (See following table)	
7*	Bearing (See following table)	
9	Tangential Pin / Disk Pin	
10	Anti-Blowout Flange	
11	Packing Flange	
12	Packing Follower	
13*	Packing Set	
	PTFE, V-Ring	
	CL150	
	NPS 14	V111433X012
	NPS 16	V167865X012
	NPS 18	V110460X012
	NPS 20	V111437X012
	NPS 24	V111699X012
	NPS 30	V111704X012
	NPS 36	V121811X012
	CL300	
	NPS 14	V111437X012
	NPS 16	V110631X012
	NPS 18	V111699X012
	NPS 20	V111704X012
	NPS 24	V111708X012
	NPS 30	V121593X012
	NPS 36	V122149X012
	Graphite	
	CL150	
	NPS 14	V111434X012
	NPS 16	V167864X012
	NPS 18	V111028X012
	NPS 20	V111438X012
	NPS 24	V111442X012
	NPS 30	V111705X012
	NPS 36	V129596X012
	CL300	
	NPS 14	V111438X012
	NPS 16	V111696X012
	NPS 18	V111442X012
	NPS 20	V111705X012
	NPS 24	V111709X012

# ENVIRO-SEAL Packing System (See figure 10)

Key	Description	Part Number	Key	Description	Part Number
				NPS 18	14B3541X032
				NPS 20	14B3541X082
				NPS 24	14B3541X042
				CL300	
10	Anti-Blow Flange			NPS 14	14B3541X082
17	Hex Jam Nut (4 req'd)			NPS 16	14B3541X052
100	Packing Flange Stud (4 req'd)			NPS 18	14B3541X042
101	Packing Flange Nut (4 req'd)			NPS 20	14B3541X062
102	Packing Flange, SST			NPS 24	14B3541X072
103	Spring Pack Assembly		106*	Anti-Extrusion Ring, Composition/graphite filled PEEK (2 req'd)	
105*	Packing Set			Single PTFE packing w/std packing box	
	Use with PTFE packing			CL150	
	CL150			CL150	
	NPS 14	14B3490X012		NPS 14	14B3489X012
	NPS 16	14B3495X012		NPS 16	14B3494X012
	NPS 18	13B9155X012		NPS 18	13B9159X012
	NPS 20	13B9164X012		NPS 20	13B9168X012
	NPS 24	12B7782X012		NPS 24	12B7783X012
	CL300			CL300	
	NPS 14	13B1964X012		NPS 14	13B9168X012
	NPS 16	14B3647X012		NPS 16	14B3642X012
	NPS 18	12B7782X012		NPS 18	12B7783X012
	NPS 20	13B9164X012		NPS 20	13B9168X012
	NPS 24	14B5730X012		NPS 24	14B5734X012
	Use with Graphite packing		107	Packing Box Ring	
	CL150		111	Tag (not shown)	
	NPS 14	14B3541X112	112	Cable Tie (not shown)	
	NPS 16	14B3541X122	113	Lubricant	

## Key 5\* Seal Ring

VALVE SIZE, NPS	SOFT SEAL		PHOENIX III SEAL			METAL SEAL
	PTFE <sup>(1)</sup>	UHMWPE <sup>(2)</sup>	PTFE	ETFE	PTFE for oxygen service	NOVEX
<b>CL150</b>						
14	V168932X012	V168932X022	V140831X012	V140831X022	V140831X032	V159013X012
16	V111337X012	V111337X022	V140857X012	V140857X022	V140857X032	V159014X022
18	V111340X012	V111340X022	V114458X012	V114458X022	V114458X032	V159026X022
20	V111343X012	V111343X022	V142359X012	V142359X022	V142359X022	V159044X022
24	V111349X012	V111349X022	V142384X012	V142384X022	V142384X032	V159146X022
30	V113350X012	---	V114472X012	---	V114472X022	V159048X022
36	V113358X012	---	V143197X012	---	V143197X022	V159051X012
<b>CL300</b>						
14	V111626X012	V111626X022	V142584X012	V142584X022	V142584X032	V164731X022
16	V111629X012	V111629X022	V140837X012	V140837X022	V140837X032	V168015X032
18	V111632X012	V111632X022	V114459X012	V114459X022	V114459X032	V167979X022
20	V111635X012	V149634X012	V114462X012	V114462X022	V114462X032	V167658X022
24	V111638X012	V111638X012	V142372X012	V142372X022	V142372X032	V164730X022
30	V113353X012	---	V114473X012	---	V114473X022	13B2252X042
36	V113361X012	---	V141335X012	---	V141335X022	13B3645X012
1. Includes FKM (fluorocarbon), NBR, EPR, CR, and PTFE 2. Includes FKM, NBR, EPR, and CR						

Figure 9. Fisher Control-Disk Wafer Style Valve Assembly

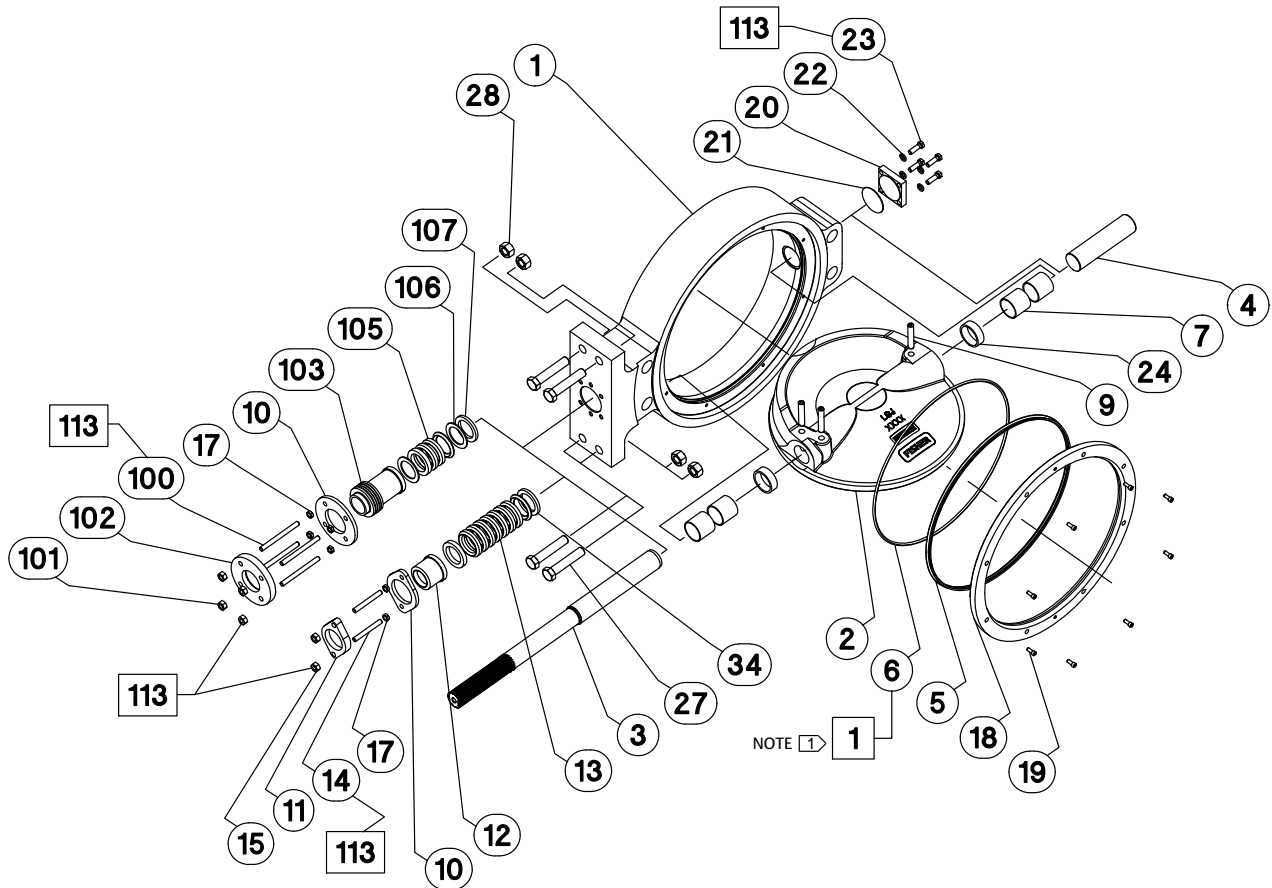

GES3130-A

PARTS NOT SHOWN: 29, 32, 33, 26, 111, 112

NOTE:

1 USE ONLY WITH SOFT SEAL AND PHOENIX III SEAL



Key 6\* Backup Ring

VALVE SIZE, NPS	FKM	NBR	EPR	CR	PTFE <sup>(1)</sup>
<b>Soft Seal PTFE / UHMWPE</b>					
<b>CL150</b>					
14	V111360X012	V111360X022	V111360X032	V111360X042	<b>V111358X012</b>
16	V111365X012	V111365X022	V111365X032	V111365X042	V111363X012
18	V111370X012	V111370X022	V111370X032	V111370X042	V111368X012
20	V111375X012	V111375X022	V111375X032	V111375X042	V111373X012
24	V111385X012	V111385X022	V111385X032	V111385X042	V111383X012
30	V115375X022	V115375X012	V115375X032	V115375X042	---
36	V113713X032	V113713X012	V113713X022	V113713X042	---
<b>CL300</b>					
14	V111648X012	V111648X022	V111648X032	V111648X042	---
16	V111653X012	V111653X022	V111653X032	V111653X042	---
18	V111370X012	V111370X022	V111370X032	V111370X042	---
20	V111375X012	V111375X022	V111375X032	V111275X042	---
24	V111658X012	V111658X022	V111658X032	V111658X042	---
30	V113523X022	V113523X012	V113523X032	V113523X042	---
36	V116146X022	V116146X012	V116146X032	V116146X042	---
<b>Phoenix III 316/PTFE, ETFE &amp; Oxygen Service</b>					
<b>CL150</b>					
14	V111647X012	V111648X022	V111648X032	V111648X042	---
16	V111360X012	V111360X022	V111360X032	V111360X042	---
18	V111365X012	V111365X022	V111365X032	V111365X042	---
20	V111375X012	V111375X022	V111375X032	V111375X042	---
24	V111385X012	V111385X022	V111385X032	V111385X042	---
30	V115375X022	V115375X012	V115375X032	V115375X042	---
36	V116146X022	V116146X012	V116146X032	V116146X042	---
<b>CL300</b>					
14	V110203X012	V110203X022	V110203X032	V110203X042	---
16	V111360X012	V111360X022	V111360X032	V111360X042	---
18	V111365X012	V111365X022	V111365X032	V111365X042	---
20	V111370X012	V111370X022	V111370X032	V111370X042	---
24	V111375X012	V111375X022	V111375X032	V111375X042	---
30	V113523X022	V113523X012	V113523X032	V113523X042	---
36	V141350X032	V141350X012	V141350X022	V141350X042	---

1. Not available in UHMWPE

## Key 7\* Bearing

VALVE SIZE, NPS	QUANTITY NEEDED	PEEK	316 / NITRIDE	BRONZE/GRAPHITE	PTFE / COMPOSITION
<b>CL150</b>					
14	3 <sup>(1)</sup>	---	V161474X022	V161474X042	V161474X052
	2 <sup>(2)</sup>	---	V111398X032	V111398X042	V111398X052
	7 <sup>(3)</sup>	V175057X012	---	---	---
16	4 <sup>(3)</sup>	V157058X012	V161472X022	V161472X042	V161472X052
18	4 <sup>(3)</sup>	V157059X012	V131700X022	V131700X042	V131700X012
20	4 <sup>(3)</sup>	V157060X012	V169414X012	V169414X032	V169414X042
24	4 <sup>(3)</sup>	V157061X012	V127742X032	V127742X042	V127742X012
30	4 <sup>(3)</sup>	V167654X012	V171363X012	V131010X012	---
36	4 <sup>(3)</sup>	13B1970X012	V171361X012	V171361X032	---
<b>CL300</b>					
14	4 <sup>(3)</sup>	V168185X012	V168528X022	V168528X042	V168528X052
16	4 <sup>(3)</sup>	V168186X012	V128066X032	V128066X052	V128066X012
18	4 <sup>(3)</sup>	V168187X012	V170455X012	V170455X032	V170455X042
20	4 <sup>(3)</sup>	V168188X012	V131699X042	V131699X032	V131699X012
24	4 <sup>(3)</sup>	V168189X012	V131703X042	V131703X052	V131703X012
30	4 <sup>(3)</sup>	13B1968X012	V175126X012	V175126X032	---
36	4 <sup>(3)</sup>	13B1971X012	V174912X042	V174912X032	---
1. Upper bearing 2. Lower bearing 3. Both upper and lower bearings					

Figure 10. ENVIRO-SEAL Packing Systems

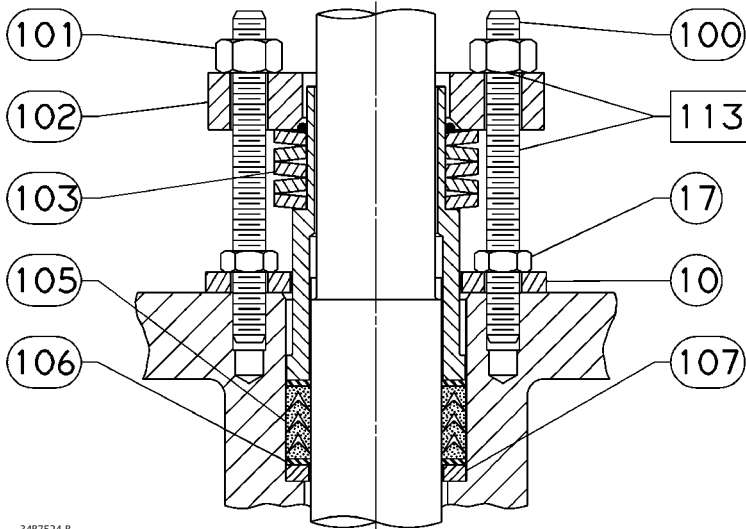

3487524-B

PTFE PACKING SYSTEM

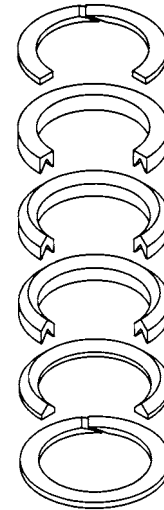

1480095-A

STACKING ORDER OF  
PTFE PACKING RINGS

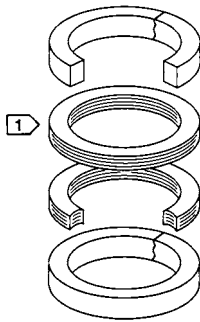

1480086-A

STACKING ORDER OF  
GRAPHITE PACKING RINGS

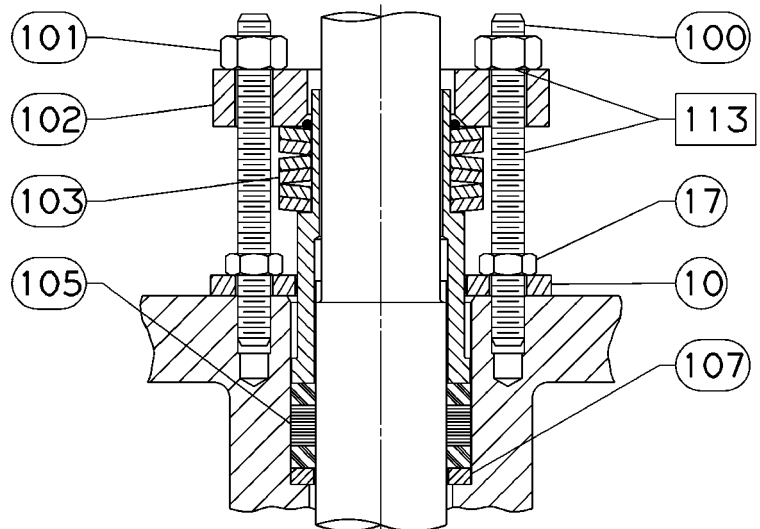

3487524-B

GRAPHITE PACKING SYSTEM

NOTES:  
① VALVES WITH SHAFTS LARGER THAN 38.1 mm (1-1/2 INCH) USE GRAPHITE RINGS

Key 21 \* Gasket<sup>(1)</sup>

VALVE SIZE, NPS	SOFT SEAL	METAL / PHOENIX III	SOFT SEAL & METAL / PHOENIX III
	Standard and NACE	Standard and NACE	For Oxygen Service
<b>CL150</b>			
14	V125000X022	V125000X012	V125000X032
16	V125001X012	V125001X012	V125001X032
18	V125002X022	V125002X012	V125002X032
20	V124604X022	V124604X022	V124604X032
24	V124603X022	V124603X012	V124603X032
30	V135139X022	V135139X012	V135139X032
36	V135138X022	V135138X012	V135138X032
<b>CL300</b>			
14	V124604X022	V124604X012	V124604X032
16	V139033X022	V139033X012	V139033X032
18	V139502X022	V139502X012	V139502X032
20	V139619X022	V139619X012	V139619X032
24	V135138X022	V135138X012	V135138X032
30	V148908X022	V148908X012	V148908X032
36	V148909X022	V148909X012	V148909X032

1. Soft Seal and Phoenix III gaskets require backup O-rings (key 6).

## Key 24 \* Thrust Bearing

VALVE SIZE, NPS	QUANTITY NEEDED	PEEK	316/NITRIDE	BRONZE/GRAPHITE	PTFE/COMPOSITE
<b>CL150</b>					
14	2		GE48766X022	GE48766X042	GE48766X052
16	2		GE49229X022	GE49229X042	GE49229X052
18	2		GE49222X022	GE49222X042	GE49222X052
20	2		GE49224X022	GE49224X042	GE49224X052
24	2	V159690X012	V127739X032	V127739X052	V127739X012
30	2	V167656X012	V171364X012	V171364X022	
36	2	13B1961X012	V171362X012	V171362X022	
<b>CL300</b>					
14	2		GE49730X022	GE49730X042	GE49730X052
16	2	GE48156X012	GE48498X022	GE48498X042	GE48498X052
18	2	GE48692X012	GG08220X012	GG08220X042	GG08220X052
20	2		GE49716X022	GE49716X042	GE49716X052
24	2	GE48758X012	GE48756X022	GE48756X042	GE48756X052
30	2	13B1959X012	V175127X012	V175127X022	
36	2	13B1962X012	V116148X012	V116148X022	

\*Recommended spare parts

Neither Emerson, Emerson Automation Solutions, nor any of their affiliated entities assumes responsibility for the selection, use or maintenance of any product. Responsibility for proper selection, use, and maintenance of any product remains solely with the purchaser and end user.

Fisher, Control-Disk, FIELDVUE, and ENVIRO-SEAL are marks owned by one of the companies in the Emerson Automation Solutions business division of Emerson Electric Co. Emerson Automation Solutions, Emerson, and the Emerson logo are trademarks and service marks of Emerson Electric Co. All other marks are the property of their respective owners.

The contents of this publication are presented for informational purposes only, and while every effort has been made to ensure their accuracy, they are not to be construed as warranties or guarantees, express or implied, regarding the products or services described herein or their use or applicability. All sales are governed by our terms and conditions, which are available upon request. We reserve the right to modify or improve the designs or specifications of such products at any time without notice.

Emerson Automation Solutions  
Marshalltown, Iowa 50158 USA  
Sorocaba, 18087 Brazil  
Cernay 68700 France  
Dubai, United Arab Emirates  
Singapore 128461 Singapore

www.Fisher.com

