

SERIES 5200G

Weatherhood Free Vent

PROTECTOSEAL

SERIES 5200G

- NEW economical / functional design
- Sizes 2" (DN 50) through 12" (DN 300)
- Vapors vent to atmosphere
- Removable weatherhood protects tank opening
- Screen protects tank's interior from debris
- Lightweight design permits easy handling
- Easy to install and maintain
- Factory inspected prior to shipment
- Available in Aluminum, Stainless Steel and Carbon Steel



OBJECTIVE

The Protectoseal Series 5200G Free Vent provides open access to the tank's vapor space and provides pressure and vacuum venting. Flange connection mounts to tank's roof nozzle. Opening is protected by removable weatherhood. Protective mesh screen is also provided to minimize the possibility of debris entering the tank opening while allowing access to the tank's interior through roof nozzle for inspection, measurement, etc. The Series 5200G Free Vent is continuously open to the atmosphere.

SPECIAL FEATURES

Fast Inspection, Easy Maintenance. Design and light weight of entire unit permits easy, convenient handling for inspection and maintenance. Coarse mesh screen prevents entry of foreign matter into tank opening.

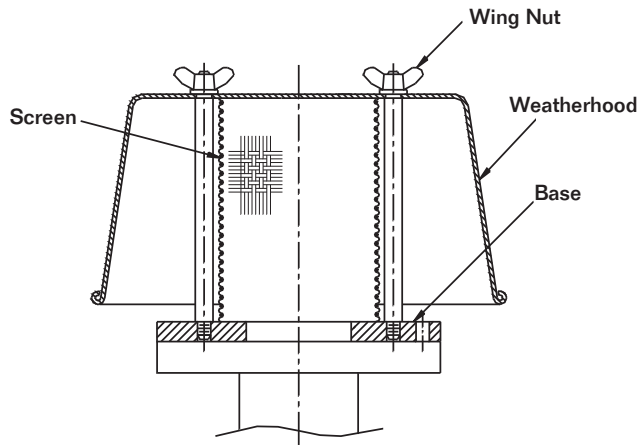

Sizes Available. 2" (DN 50) through 12" (DN 300) units flanged to mate with 125# / 150# ANSI and DIN PN 16 flat face flanges. For larger sizes or for raised face flanges refer to Series 5200D; contact factory or visit website for details.

CONSTRUCTION

A comprehensive range of materials is offered as shown in the chart below. Other materials and features can be furnished upon request.

Series	Base Flange	Weather-Hood	Screen	Guides
A5200G	Aluminum	Aluminum	Aluminum	Aluminum
C5200G	Steel	Steel	Steel	Steel
F5200G	316 S.S.	316 S.S.	316 S.S.	316 S.S.

*Vents flanged to mate with 125# / 150# ANSI and DIN PN 16 flat face flanges.
For raised face flanges refer to Series 5200D; contact factory for details.*

SERIES 5200G PART NUMBERING SYSTEM

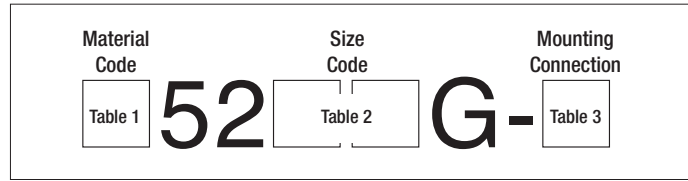

Table 1 - Material

Material	Option Code
Aluminum	A
Carbon Steel	C
316 S.S.	F

Table 2 - Size

Size	Option Code
2" (DN 50)	02
3" (DN 80)	03
4" (DN 100)	04
6" (DN 150)	06
8" (DN 200)	08
10" (DN 250)	10
12" (DN 300)	12

Consult Factory for sizes larger than 12"

Table 3 - / Mounting Connection

Connection*	Option Code
Mates with ANSI 125 / 150# Flange	1
Mates with DIN PN 16 Flange	2

* All flanges are flat face, consult factory for raised face flanges (refer to Series 5200D)

PART NUMBER EXAMPLE: A5206G-1

Series 5200G Weatherhood Free Vent; Material - Aluminum; Size - 6";
Mounting Connection - ANSI 125# Flat Face Flange

DIMENSIONS & ORDERING INFORMATION (Dimensions shown are for reference only. Contact Factory for certified drawings.)

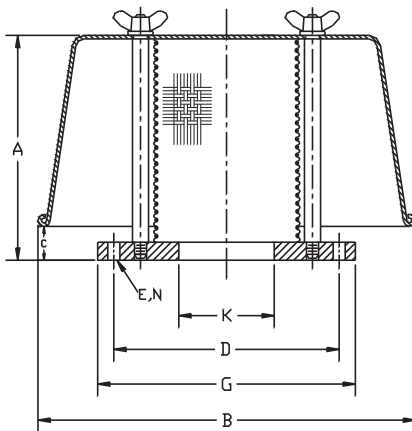

Cat. No.*	Pipe Size K	Ht. A	Width B	C	B.C. D	Dia. E	Dia. G	Holes N
□ 5202G-1	2"	6 ³ / ₁₆ "	8 ¹ / ₂ "	1 ¹ / ₁₆ "	4 ³ / ₄ "	3/4"	6"	4
□ 5202G-2	DN50	157mm	216mm	17mm	125mm	18mm	165mm	4
□ 5203G-1	3"	7 ⁹ / ₁₆ "	12 ³ / ₄ "	2 ¹ / ₁₆ "	6"	3/4"	7 ¹ / ₂ "	4
□ 5203G-2	DN80	192mm	324mm	52mm	160mm	18mm	200mm	8
□ 5204G-1	4"	7 ¹³ / ₁₆ "	12 ³ / ₄ "	2 ⁵ / ₁₆ "	7 ¹ / ₂ "	3/4"	9"	8
□ 5204G-2	DN100	198mm	324mm	59mm	180mm	18mm	220mm	8
□ 5206G-1	6"	9 ¹¹ / ₁₆ "	14 ⁹ / ₁₆ "	2 ⁷ / ₁₆ "	9 ¹ / ₂ "	7/8"	11"	8
□ 5206G-2	DN150"	246mm	381mm	62mm	240mm	22mm	285mm	8
□ 5208G-1	8"	11 ¹ / ₁₆ "	17 ¹ / ₂ "	2 ⁷ / ₈ "	11 ³ / ₄ "	7/8"	13 ¹ / ₂ "	8
□ 5208G-2	DN200	284mm	445mm	73mm	295mm	22mm	340mm	12
□ 5210G-1	10"	12 ¹ / ₂ "	23 ⁵ / ₈ "	1 ¹⁵ / ₁₆ "	14 ¹ / ₄ "	1"	16"	12
□ 5210G-2	DN250	318mm	591mm	49mm	355mm	26mm	405mm	12
□ 5212G-1	12"	13 ³ / ₄ "	25 ⁵ / ₈ "	2 ³ / ₁₆ "	17"	1"	19"	12
□ 5212G-2	DN300	337mm	651mm	56mm	410mm	26mm	460mm	12

Contact Factory for larger sizes.

* To complete Cat. No., refer to Table 1 - Material Option Code in the Part Numbering System Chart at the top of this page.



225 Foster Ave., Bensenville, IL 60106-1690
P 630.595.0800 F 630.595.8059
info@protectoseal.com www.protectoseal.com