



The MeQ-Pak utilises its self-powered turbine to provide energy to drive the injection system.

The flow of product through the MeQ-Pak drives the turbine, which in turn drives the positive displacement pump heads via a gearbox. The number of pump heads is determined by the ratio of additive injection required. As the main product flow varies, the proportional change in speed of the turbine, ensures that the rate of injection is adjusted accordingly.

The advantages of this self-contained system are its mechanical simplicity and rugged design requiring minimum maintenance and operator interaction. This reliability makes the MeQ-Pak extremely cost-effective during operation and installation.

General Arrangement

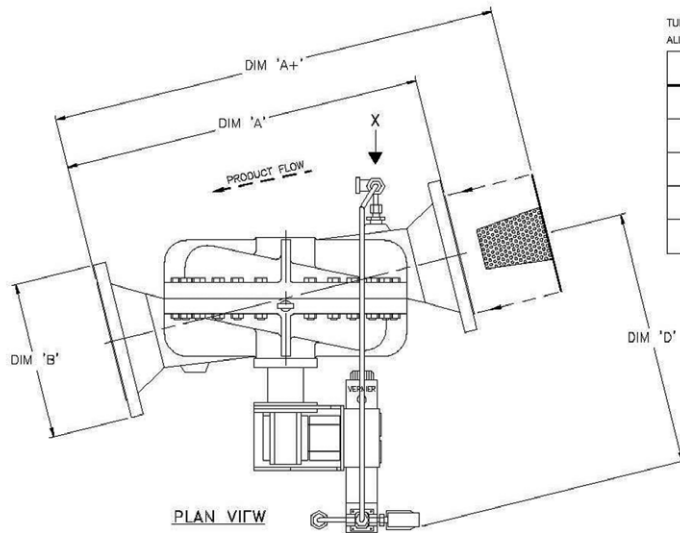

TURBINES DIM'S ARE FOR ANSI.150 R.F. FLANGES.
ALL DIMENSIONS ARE FOR REFERENCE ONLY.

TURBINE	DIM 'A'	DIM 'A+'	DIM 'B'	DIM 'C'	DIM 'D'
2"	370mm	371.5mm	ø153mm	217mm	580mm MIN
4"	503mm	504.5mm	ø230mm	290mm	580mm MIN
6"	703mm	704.5mm	ø280mm	320mm	610mm MIN
8"	803mm	804.5mm	ø343mm	415mm	610mm MIN
10"	933mm	934.5mm	ø407mm	480mm	620mm MIN

DIM 'A+':- INCLUDES WITCHES HAT STRAINER, WHEN FULLY INSERTED.
DIM 'C':- DEPENDING ON ADDITIONAL EQUIPMENT FITTED.
DIM 'D':- DEPENDING ON EQUIPMENT FITTED.

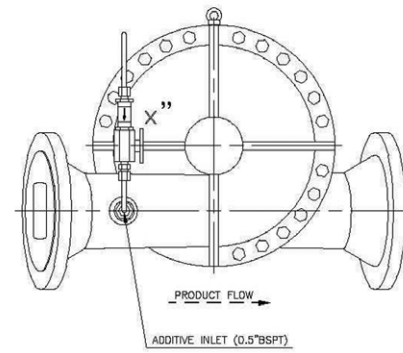
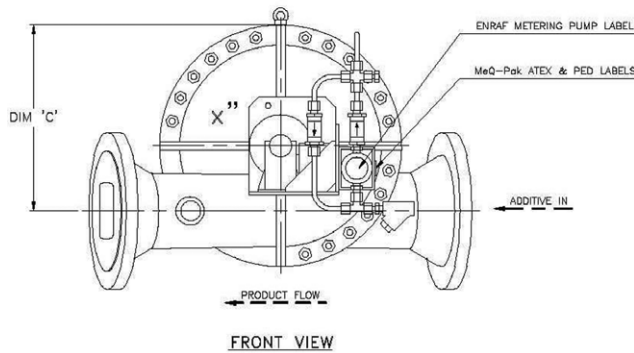

VIEW ON ARROW 'X'
SHOWING PIPEWORK FROM PUMP HEAD
TO ADDITIVE INLET

Benefits

- Proven Technology
- Simple Installation
- Proven Reliability
- Low Maintenance
- Self Contained

Features

Arrangements

The MeQ-Pak turbine driven injector is capable of being mounted both horizontally and vertically. However to facilitate non-horizontal installation, certain components must be re-orientated. The MeQ-Pak will therefore be supplied for standard horizontal mounting as per General Arrangement drawing, unless otherwise requested.

Pump Selection

The Pump Selection Table is offered as a guide for the pricing of different

MeQ-Pak configurations. The actual quantity and size of pumps is dependent on the number of additives and the injection rate(s) required.

Additive Supply

The MeQ-Pak requires a constant, positive head, additive supply. Typically this would be an appropriately sized additive storage tank supplying a minimum of 0.3 metres of positive head, and rigorously purged of all air. Call factory for range of additive supply tanks available.

Operating Range

Each metering pump is supplied with a fully adjustable stroke range, from 0-100% via a lockable vernier dial. The final MeQ-Pak configuration will be engineered with the target injection rate at the mid range point of the stroke size, with upper and lower injection rates specified by Honeywell Enraf.

Multiple Additives

Multiple additives are capable of being injected via a single MeQ-Pak. A maximum of 4 separate additives lines are possible, dependent upon injection rates required. Call factory for multiple additive pricing.

Calibration

To facilitate the clean and safe calibration of the MeQ-Pak turbine, in-line calibration vessels are available as an upgrade option. Approved, laboratory certified, glass calibration vessels, sized to suit are pre-installed into the additive supply line and can be utilised via a 3-way valve, to calibrate the injection rate without the need for additive exposure or operational rescheduling.

Technical Specification

Flow

Accuracy	:	Better than $\pm 1.5\%$		
Repeatability	:	Better than $\pm 1.0\%$		
Max Flow - Wildstream	:	4"	35 - 135 M ³ /hr	
	:	6"	50 - 275 M ³ /hr	
	:	8"	90 - 500 M ³ /hr	
	:	10"	150 - 800 M ³ /hr	
Max Flow - Additive	:	4"	8.00 L/min	3500 ppm
	:	6"	10.70 L/min	2500 ppm
	:	8"	19.60 L/min	2300 ppm
	:	10"	19.60 L/min	1500 ppm
Max Working Pressure	:	15 Bar		
Max Viscosity - Wildstream	:	10 cst.		
Max Viscosity - Additive	:	2000 cst.		
Pressue Drop - Wildstream	:	Less than 1 Bar		
Additive Supply Pressure	:	300mm Positive Head - Minimum		

Environmental

Ambient Temperature	:	-25°C to +65°C
Humidity	:	5 to 95% without condensation.
Approvals	:	ATEX, CE Marked for Zone 1
	:	PED 8" & 10" SEP 4" & 6"
T Rating	:	T4

Materials

Turbine Casing	:	Cast Steel - ASTM A216 WCB
Turbine Axial Flow Impeller	:	304 Stainless Steel
Turbine Mechanical Seal	:	Stainless Steel, Carbon, Viton
Metering Pumps	:	316 Stainless Steel
Metering Pump Seals	:	PTFE
Mechanical Drive Casing	:	Cast Iron - Grade 250
Paint Finish	:	Hammercote Enamel - Ref. H/126

Mechanical

Major Components	:	Strainer, Metering Pump(s), Turbine Unit, Mech Seal, Check Vv Gearbox, Coupling & Spider, MGH Drive Mechanism, Relief V
Turbine Connections	:	ANSI 150 lb RF Flanged
Additive Inlet Connection(s)	:	1/2", 3/4" or 1"NPT - Arrangement depending

Weight

4" Turbine Assembly	:	Approx 150 kg (Depending on No. of Pumps fitted)
6" Turbine Assembly	:	Approx 240 kg (Depending on No. of Pumps fitted)
8" Turbine Assembly	:	Approx 380 kg (Depending on No. of Pumps fitted)
10" Turbine Assembly	:	Approx 560 kg (Depending on No. of Pumps fitted)

Options

Bypass	:	System Bypass Valve
Calibration	:	In-line calibration vessel (1, 2 & 5 Litre)
Reconciliation	:	Additive discharge line PD Meter
Additive Storage	:	Additive Supply Tanks - Various models

Pump Selection Table

Pump Selector - PPM Range							
Turbine Size	A	B	C	D	E	EE	EEE
4"	0-50	51-200	201-450	451-800	801-1350	801-2700	N/A
6"	0-20	21-80	81-150	151-300	301-550	301-1100	301-1650
8"	0-10	11-40	41-90	91-175	171-280	171-560	171-840
10"	0-7	7-30	31-60	61-110	111-190	111-380	111-570

Identification Code

Pos 1, 2 Manufactured Product													
6	9												
Pos 3, 4 Product Family													
1	0	Turbine Driven Injector											
Pos 5, 6 Model													
M	Q	MeQ-Pak											
Pos 7, 8 Size													
0	4	4" (WildStream Flowrates 35 - 135 M ³ /hr)											
0	6	6" (WildStream Flowrates 50 - 275 M ³ /hr)											
0	8	8" (WildStream Flowrates 90 - 500 M ³ /hr)											
1	0	10" (WildStream Flowrates 150 - 800 M ³ /hr)											
Pos 9 Pump Selection (See Pump Selector Table)													
A		Pump Package A											
B		Pump Package B											
C		Pump Package C											
D		Pump Package D											
E		Pump Package E											
F		Pump Package F											
G		Pump Package G											
H		Pump Package H											
Pos 10 System Bypass Valve													
0		Not required											
1		Yes											
Pos 11 Inline Calibration Vessel													
0		Not Required											
1		1 Litre											
2		2 Litre											
5		5 Litre											
Pos 12 Flowmeter													
0		Not Required											
1		Yes											
Pos 13 N/A													
0		Not Required											
6	9	1	0	M	Q	0	4	A	0	0	0	0	Typical identification code
6	9	1	0	M	Q							0	Your identification code

For More Information

To learn more about Honeywell Enraf's solutions, contact your Honeywell Enraf account manager or visit www.honeywellenraf.com.

Americas

Honeywell Enraf Americas, Inc.
2000 Northfield Ct.
Roswell, GA 30076
USA
Phone: +1 770 475 1900
Email: enraf-us@honeywell.com

Asia Pacific

Honeywell Pte Ltd.
17 Changi Business Park Central 1
Singapore 486073
Phone: +65 6355 2828
Email: enraf-sg@honeywell.com

Europe, Middle East and Africa

Honeywell Enraf
Delftechpark 39
2628 XJ Delft
The Netherlands
Phone: +31 (0)15 2701 100
Email: enraf-nl@honeywell.com

Honeywell Enraf