



storage tanks



lpg vessels

HT-1137

PRODUCT DETAILS

Highland Tank is the leader in the steel tank industry and has been building ASME pressure vessels for decades. Years of experience enable Highland Tank to provide solutions to the most challenging tank needs. A team of professionals in design, engineering, fabrication and service bring many features and tactics from other steel tank fields to the LPG market. These innovative techniques improve the overall quality and life of the vessel while simplifying tank installation and everyday use. The flexibility to build custom vessels sets Highland Tank apart from the competition.



custom quality in every detail



LPG Vessels

Highland Tank's LPG vessels are designed and constructed to ASME, Section VIII, Division I and NFPA 58 "Liquefied Petroleum Gas Code" for stationary use vessels. Standard vessel sizes for industrial and commercial bulk uses range from 3,900 to 60,000 gallons. LPG vessels are constructed using SA516 Grade 70 steel, employing full-penetration butt welds on all seams. Highland Tank incorporates ASME 2:1 elliptical heads for their functionality and to maximize volume in a limited amount of space. Normal operating pressure is 250 psi at 125° F. Lifting lugs are standard to facilitate offloading and placement.

Large LPG storage vessels provide fuel for a wide range of industrial, commercial and agricultural industries including:

- Commercial and residential heating fuel
- Fleet vehicle fueling by school districts, government agencies and public transit companies
- Agricultural: crop drying, vehicle fuel and weed control
- Redundant fuel source for hospitals and other institutional, commercial and industrial properties
- Standby electric generators
- Distribution for consumers
- Autogas

pre-engineered design options

solution oriented designs



Aboveground

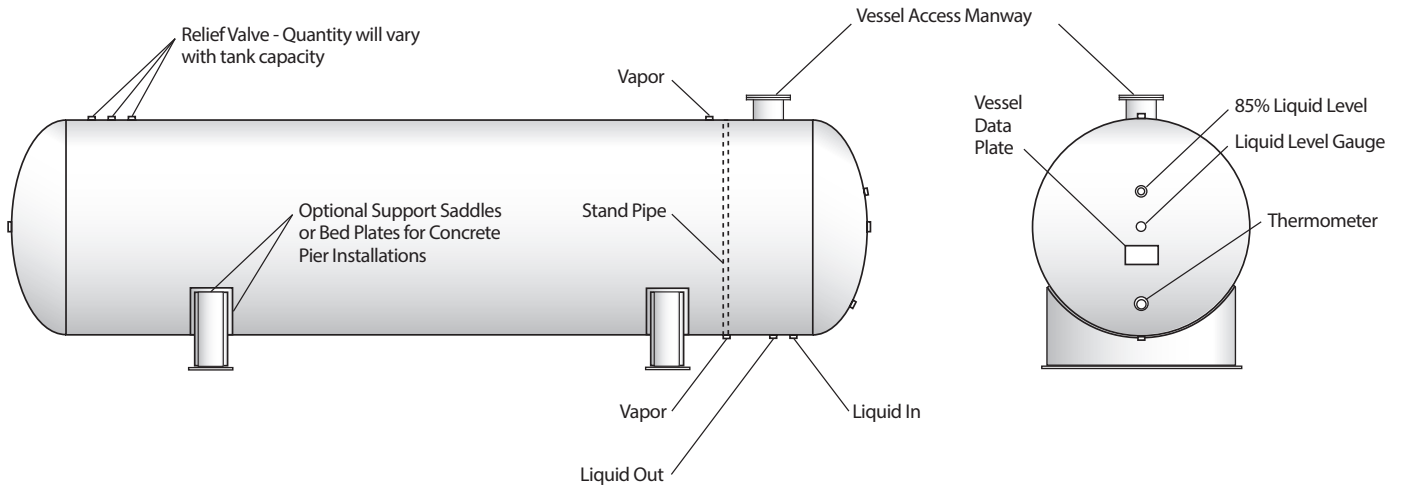

LPG Vessel Sizing Guide

| Volume USWG | Diameter | Straight Shell Length | Overall Length |
|-------------|----------|-----------------------|----------------|
| 3,900 | 7'-0" | 12'-4" | 15'-2" |
| 6,565 | 7'-0" | 20'-11" | 24'-9" |
| 12,000 | 7'-0" | 40'-6" | 44'-4" |
| 18,000 | 9'-1" | 35'-6" | 40'-5" |
| 30,000 | 9'-1" | 60'-3" | 65'-2" |
| 30,000 | 11'-0" | 40'-4" | 46'-2" |
| 40,000 | 11'-0" | 54'-5" | 60'-3" |
| 50,000 | 11'-0" | 68'-5" | 74'-3" |
| 60,000 | 11'-0" | 80'-6" | 88'-10" |

Custom sizes available

underground design

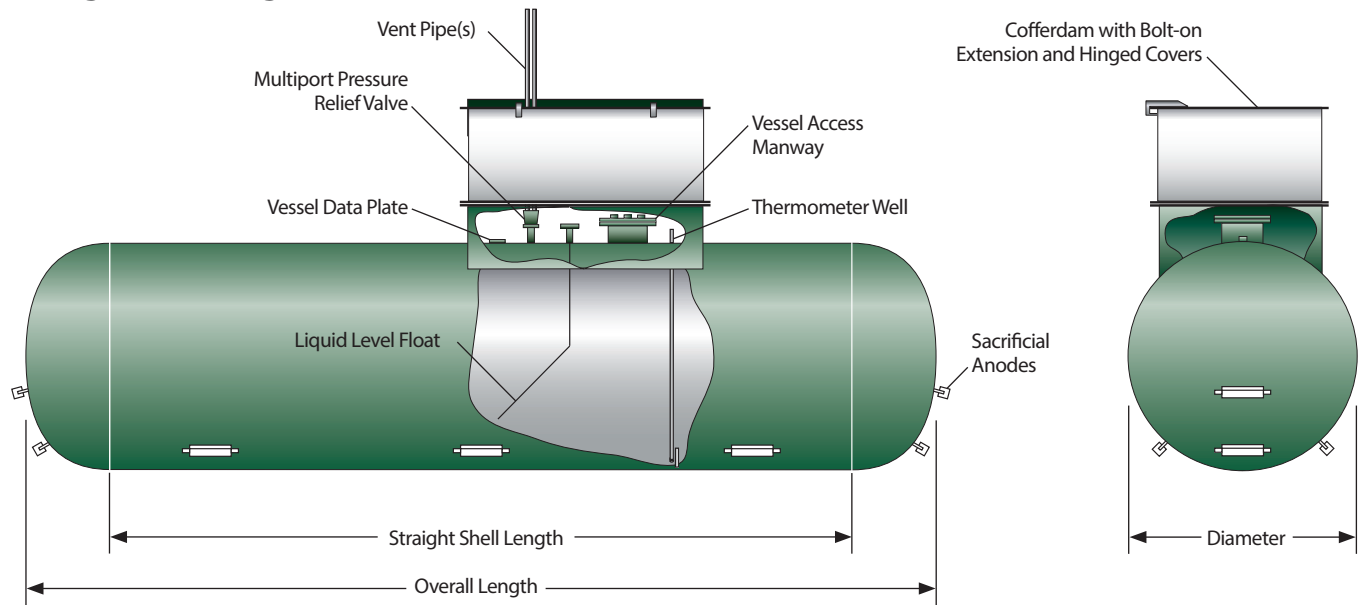

Standard Vessel Features

- Volume: 3,900 to 60,000 USWG
- ASME "U" Stamp
- 2:1 Elliptical heads – utilizes less space on property
- National Board Registration
- Test Pressure 325 PSI (250 PSI WP) at 125° F
- RT3 X-Ray Inspection
- Flanged manway
- SA516-70 high strength carbon steel
- Grounding connectors
- Grit blasted/coated with white urethane topcoat (aboveground)
- Grit blasted/coated with 75 mils of HighGuard coating (underground)
- External connections and outlets (valves or fittings not included)
- Lift Lugs
- Cofferdam work chamber for easy access (underground)

bulk lpg storage vessel applications

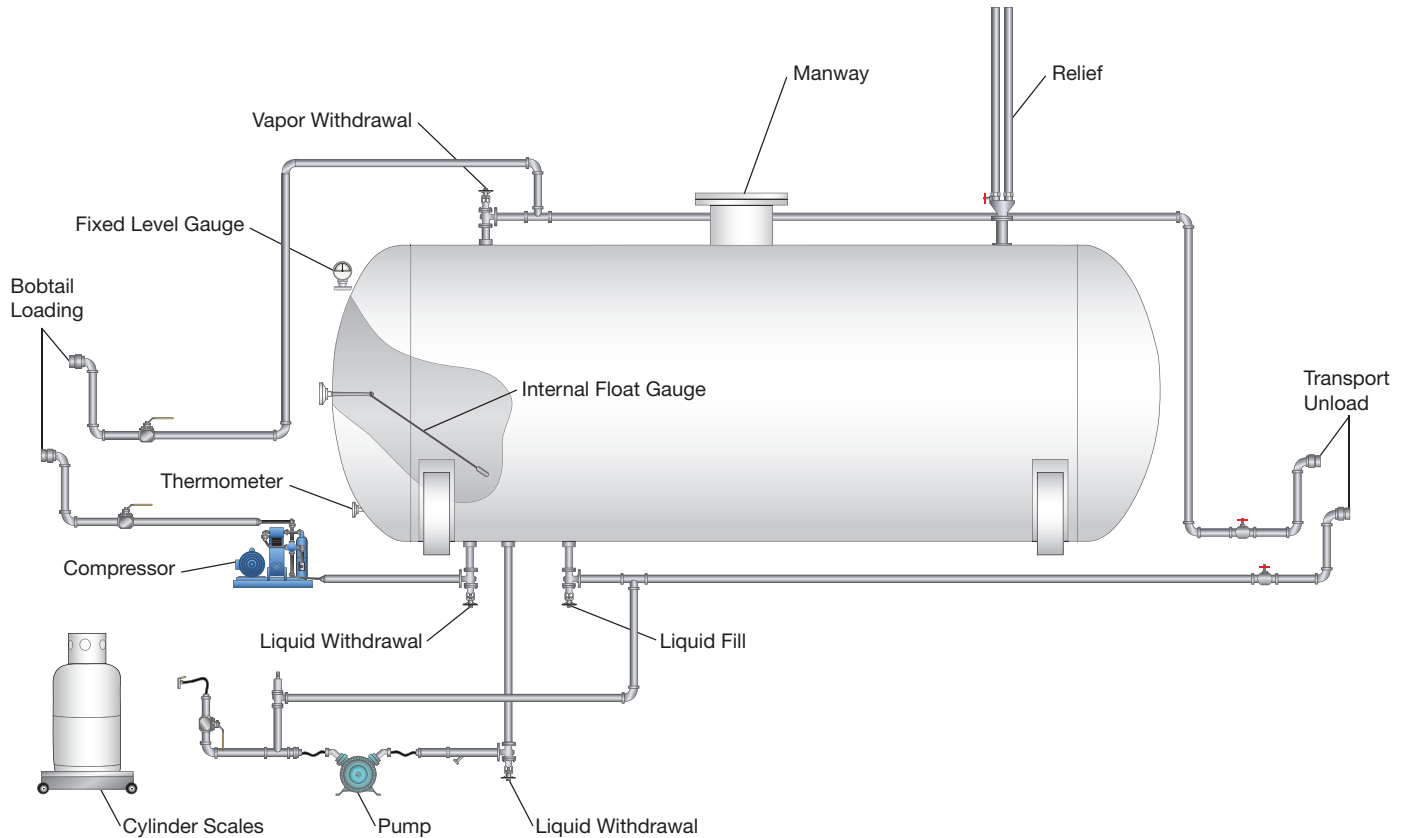

Bulk LPG vessels are used in several types of facilities. They store large amounts of propane to help a supplier meet the demand of the market in the area. Bulk facilities are used to distribute propane to residential and commercial consumers. Vessels are typically designed to load bobtails.

In many parts of the country, petroleum marketers are adding propane to their product mix. These facilities are installing aboveground or underground LPG vessels alongside atmospheric petroleum tanks.

In recent years, vast gas reserves trapped in the Marcellus Shale and other shale gas plays have been exploited. Naturally occurring hydrocarbons, known as NGL, are found in natural gas that is sourced from gas wells or associated with crude oil. These byproducts of natural gas have increased significantly with shale gas exploration and hydraulic fracturing.

NGL products such as propane and butane are marketed to consumers. This has resulted in the development of new bulk facilities to store LPG.

In most cases, bulk plant facilities install aboveground vessels, but more facilities are moving to underground vessels each year.

Bulk plant LPG vessels are fitted with the appropriate fittings based on the application. Highland Tank has the flexibility to do custom manufacturing of LPG vessels. This can be an important factor in providing the perfect engineered solution for a customer.

autogas applications

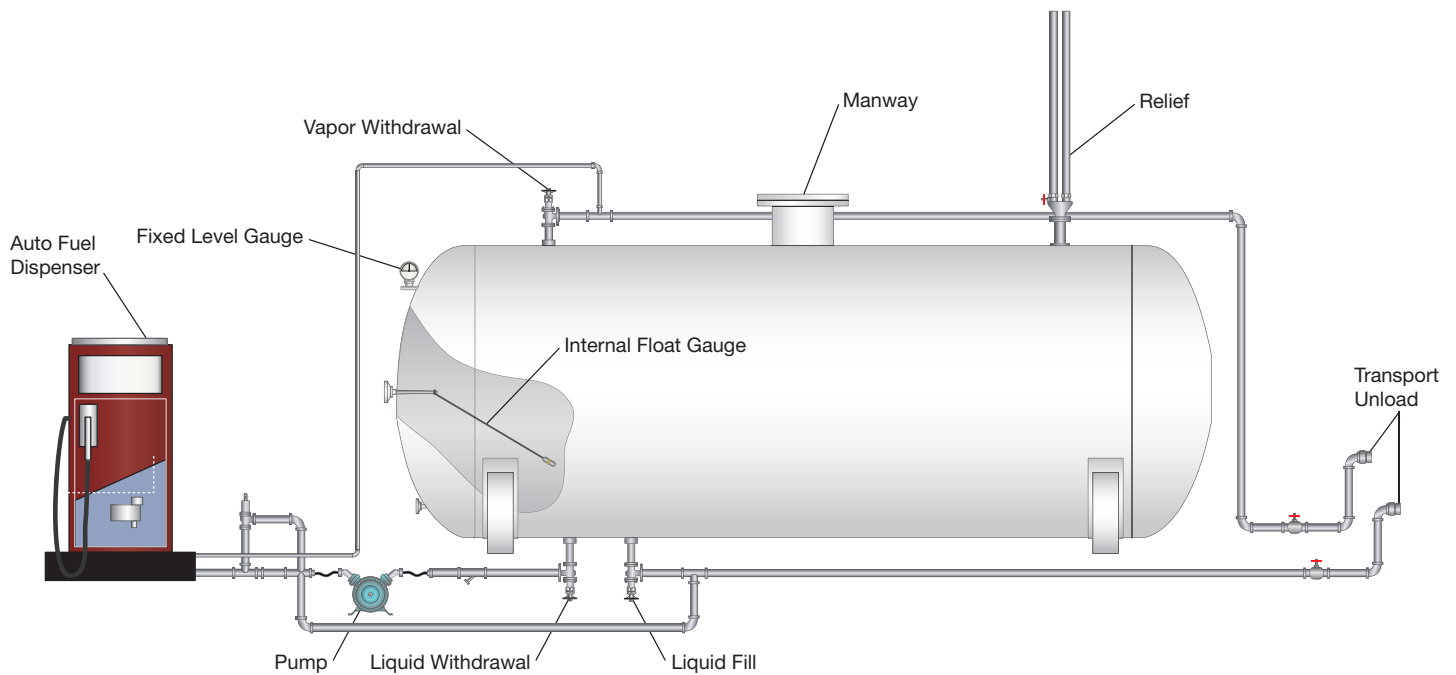

With gasoline prices constantly on the rise, the focus has been put on alternative fuels like never before. One low profile alternative fuel being considered is propane autogas.

Propane is a naturally occurring byproduct of domestic oil refining and natural gas processing. It is 270 times more compact as a liquid than as a gas, making propane highly economical to store and transport. When propane is used as an on-road engine fuel, it is called propane autogas.

Worldwide, there are more than 15 million vehicles using propane autogas, making it the third most common engine fuel behind gasoline and diesel fuel. In the U.S., propane autogas fuels about 270,000 vehicles with 2,500 fueling stations found across the United States.

Propane autogas is domestically produced, costs approximately 30 to 40 percent less than gasoline per gallon and does not rob a car of its performance unlike other alternative fuels.

With an octane level of 105, autogas will not take the power out of your alternative fueled vehicle. Additionally, autogas burns cleaner than gasoline, which means a smaller carbon footprint. The autogas market is the sleeping giant of alternative fuel, and Highland Tank can help customers get ahead of the curve.

space heating fuel applications

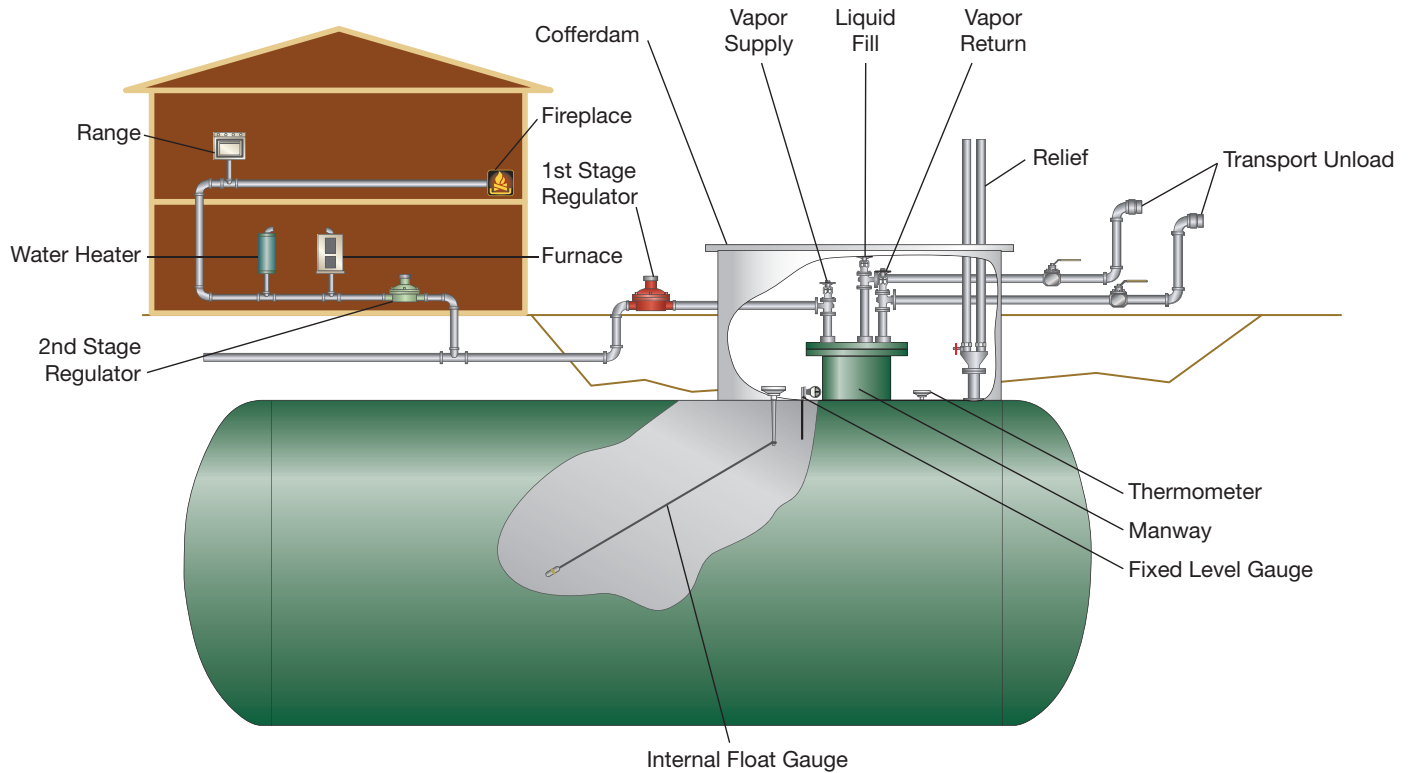

More than one million commercial establishments use propane for heating and cooling air, heating water, cooking, refrigeration, drying clothes, barbecuing and lighting.

More than 350,000 industrial sites rely on it for space heating, brazing, soldering, cutting, heat treating, annealing, vulcanizing and many other uses.

Petrochemical industries use propane to manufacture plastics.

Propane is also a staple on 660,000 farms where it is used in everything from grain drying to planting seeds, ripening fruit and running a variety of farm equipment such as irrigation pumps and standby generators.

Highland Tank will work with you to tailor our propane vessels to meet your specific design criteria.

Our ability to custom-fabricate propane vessels for almost any application is uncommon in the LPG industry.

Highland Tank's Exclusive
State-of-the-Art
Underground Vessel Technology

There are many good reasons to install propane vessels underground. Many facilities have limited real estate, and the space requirements for aboveground bulk storage vessels are prohibitive. Plus, underground LPG vessels provide added safety in the unlikely case of fire or other natural disaster.

Highland Tank's underground HighGuard vessels combine the structural strength of rugged steel construction with the lasting protection of our unique coating to produce a propane storage vessel second to none.

HighGuard features a strong dielectric coating of high solids polyurethane for protection, even under the most difficult conditions. HighGuard resists surface damage from impact or abrasion.

After manufacturing and rigorous testing, the vessel's exterior surfaces are commercially blasted with steel grit in preparation for coating. This process provides a superior coating adhesion. The protective coating is a dense, two-component polyurethane coating system with impact properties and tensile strength. Finished vessels have an even application of 75 mils over the entire surface of the tank.



Our Quality Control team then conducts a 15,000 volt spark test to ensure the coating integrity and guarantee effective corrosion protection.

Highland Tank is so confident in HighGuard that we stand behind it with a 10-year warranty – a warranty that is unique to the propane industry.



Highland Tank Raises the Bar in
LPG Vessel Manufacturing

- » Tradition of providing unmatched quality and service
- » American made by skilled craftsmen
- » State-of-the-art coatings
- » Fabrication techniques that simplify installation & tank access
- » Fixed pricing
- » Timely delivery
- » Turnkey solutions from engineering to manufacturing to installation
- » Custom Fabrication



Stoystown, PA
One Highland Road
Stoystown, PA 15563-0338
814.893.5701

Manheim, PA
4535 Elizabethtown Road
Manheim, PA 17545-9410
717.664.0600

Watervliet, NY
958 19th Street
Watervliet, NY 12189-1752
518.273.0801

Greensboro, NC
2700 Patterson Street
Greensboro, NC 27407-2317
336.218.0801

Friedens, PA
1510 Stoystown Road
Friedens, PA 15541-7402
814.443.6800

Clarkston, MI
4701 White Lake Road
Clarkston, MI 48346-2554
248.625.8700

Mancelona, MI
9517 Lake Street
Mancelona, MI 49659-7968
231.587.8412



PROUDLY MADE IN AMERICA

© Highland Tank - HT-1137 - 11/2020