

Features

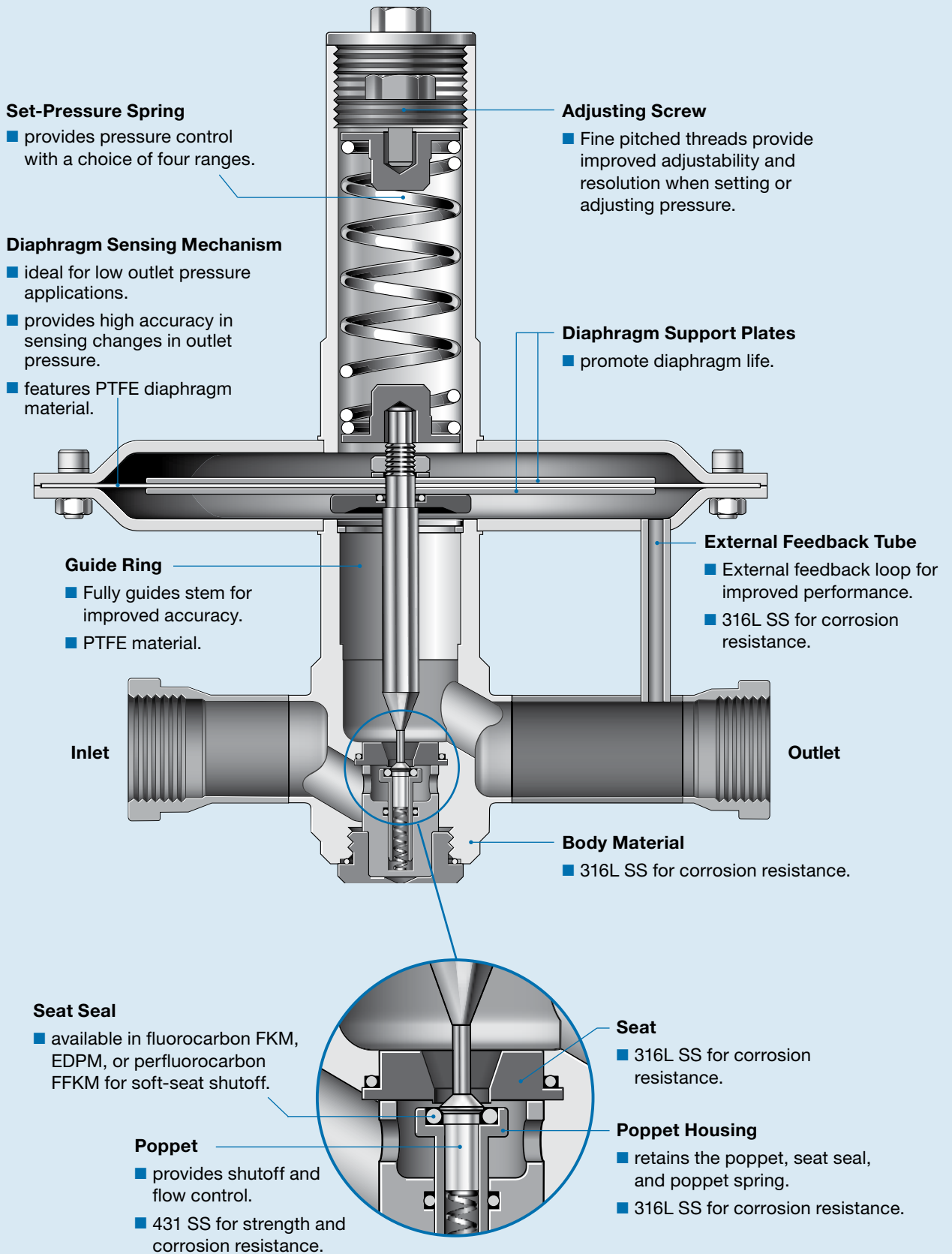

Tank Blanketing

What is Tank Blanketing

Tank blanketing, also known as padding, is the introduction of an inert gas into the vapor space of a storage tank. The pressure of the blanketing gas, usually nitrogen, is slightly higher than atmospheric pressure. The pressure requirement is low because higher pressures do not significantly improve results and waste expensive blanketing gas. Also storage tanks have thin walls which are not designed for high-pressure-containment applications. Tank blanketing is required in many industries where pressure-tight tanks are used for storage including the pharmaceutical, biochemical, electronics, sanitary, and waste water treatment industries.

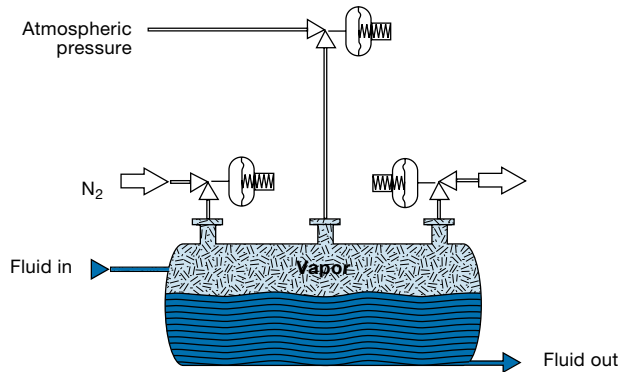

Purpose of Tank Blanketing

Tank blanketing is used for several reasons depending on the application:

- **Increase product shelf life and prevent tank corrosion.**
 Tank blanketing can prevent air from entering the storage tank. Air contains oxygen, moisture, and other contaminants which can degrade or contaminate the stored product or could lead to internal tank corrosion.
- **Improve safety.** Tank blanketing can reduce the oxygen content in the vapor space. The reduced oxygen content lowers the risk of combustion.
- **Ensure compliance with environmental standards.**
 Tank blanketing can dilute toxic vapors with inert gas to keep volatile and hazardous vapors from escaping to the atmosphere, thus ensuring compliance with emission requirements.
- **Maintain structural integrity of tank.** Tank blanketing can prevent tank collapse when the internal pressure drops, or prevent tank rupture when the internal pressure increases. The Internal pressure can drop with a decrease in temperature or when liquid is removed from the tank. The internal pressure can rise with an increase in temperature or when liquid is added to the tank.

Types of Tank Blanketing Pressure Regulators

There are two types of RHPS series tank blanketing pressure regulators:

- pressure-reducing regulators
- vapor recovery regulators (back-pressure controllers)

Tank Blanketing with Positive Pressure

Gas blanketing and vapor recovery are two techniques that can safely and effectively contain volatile vapors in tanks and other process vessels, preventing them from escaping into the atmosphere. The combination of gas blanketing and vapor recovery devices maintains a constant pressure in the tank's vapor space above the stored fluid. As a result, there will always be a constant pressure in the tank during pumping operations or when the temperature changes.

Positive Pressure Tank Blanketing with TBRS Series Pressure-Reducing Regulators

When the tank suddenly cools, the vapors inside the tank condense causing the tank pressure to decrease. The regulator opens which allows blanketing gas into the tank. Blanketing regulators also maintain a constant pressure in the tank during pump out to prevent the tank from collapsing.

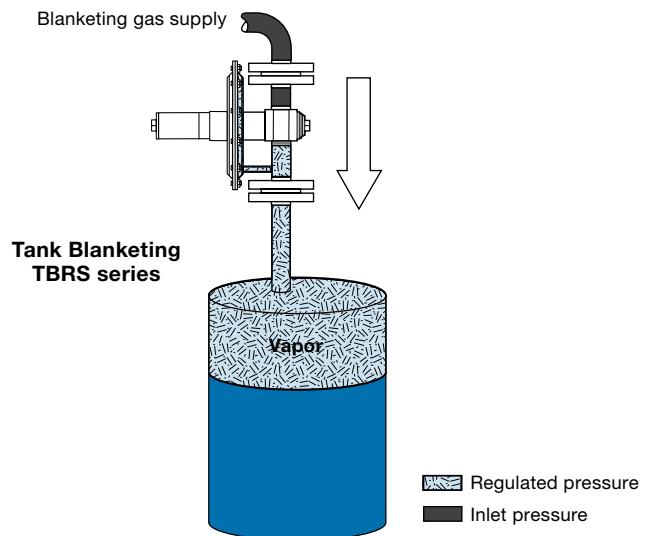

Tank Blanketing

Vapor Recovery with TBVS Series Back-Pressure Regulators

When pressure inside the tank rises due to pump-in or thermal heating, the back-pressure regulator vents the excess pressure to an appropriate vapor recovery system. This prevents vapors from escaping into the atmosphere. Emergency vents or safety relief valves must be installed in the event of back-pressure regulator failure.

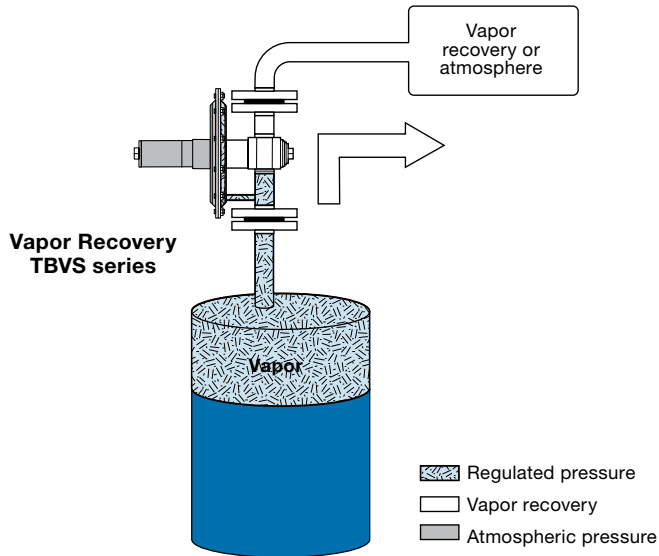

Testing

Every RHPS series tank blanketing regulator is factory tested for shell and seat leakage with nitrogen or air at 232 psig (16.0 bar), or its maximum rated pressure if less than 232 psig (16.0 bar). Shell testing is performed to a requirement of no detectable leakage with a liquid leak detector.

Cleaning and Packaging

Every RHPS series tank blanketing regulator is cleaned and packaged in accordance with Swagelok *Standard Cleaning and Packaging (SC-10)*, MS-06-62.

Cleaning and packaging to ensure compliance with product cleanliness requirements stated in ASTM G93 Level C, is available as an option.

Oxygen Service Hazards

For more information about hazards and risks of oxygen-enriched systems, see the Swagelok *Oxygen System Safety* technical report, MS-06-13.

- ⚠ **RHPS series tank blanketing regulators are not "Safety Accessories" as defined in the Pressure Equipment Directive 97/23/EC.**
- ⚠ **Do not use the regulator as a shutoff device.**

Low-Pressure, Spring-Loaded, Pressure-Reducing Regulators— TBRs4 Series

Features

- Spring-loaded pressure control
- Diaphragm sensing mechanism
- 316L stainless steel materials of construction
- Large diaphragm to seat ratio
- Compliance with FDA/USP class VI

Options

- Special cleaning to ASTM G93 Level C



Technical Data

Series	Maximum Inlet Pressure psig (bar)	Maximum Outlet Control Pressure psig (in. H ₂ O, mbar)	Sensing Type	Temperature Range °F (°C)	Flow Coefficient (C _v)	Seat Diameter in. (mm)	Inlet and Outlet Connections	Weight lb (kg)
TBRs4	87.0 (6.0)	11.6 (321, 800)	Diaphragm	-4 to 212 (-20 to 100)	0.20	0.16 (4.0)	1/2 in. ISO/BSP parallel thread, sanitary clamp (BSOD), ASME or DIN flange	3.5 (1.6) without flanges

Materials of Construction

TBRs4 Series Regulator

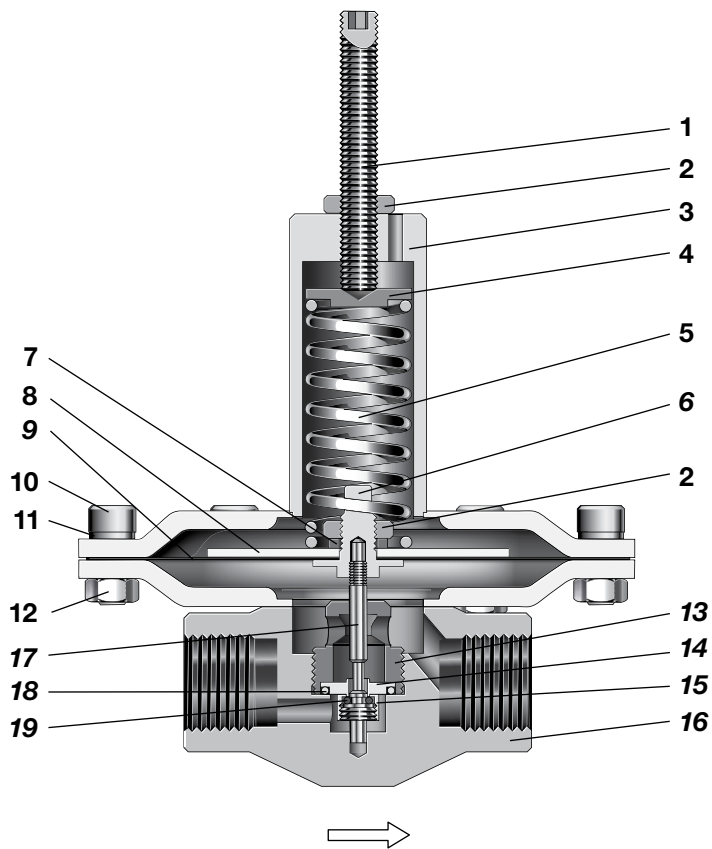

Component	Material / Specification
1 Set screw	A2-70
2 Nut	A2
3 Spring housing assembly	316L SS / A479 or EN10088
4 Spring guide	
5 Set spring	302 SS / A240
6 Clamp ring	316L SS / A479 or EN10088
7 Lock washer	A4
8 Diaphragm plate	316L SS / A479 or EN10088
9 Diaphragm	PTFE
10 Socket-head cap screw	A4-80
11 Lock washer	A2
12 Nut	
13 Seat retainer	316L SS / A479 or EN10088
14 Seat	
15 Poppet screw	
16 Body assembly (body, bottom dish)	316L SS / A479 or EN10088
17 Poppet	
18 Seat seal	PTFE
19 Poppet O-ring	Kalrez® 6230

Wetted lubricants: Silicone-based and synthetic hydrocarbon-based

Wetted components listed in *italics*.

Dimensions

Dimensions, in inches (millimeters), are for reference only and are subject to change.

End Connection Size and Type	A in. (mm)
1/2 in. female ISO/BSP parallel thread	2.95 (75.0)
DN15 PN16 flange	8.31 (211)
1/2 in. ASME class 150 flange	9.09 (231)
1/2 in. sanitary clamp (BSOD)	9.06 (230)

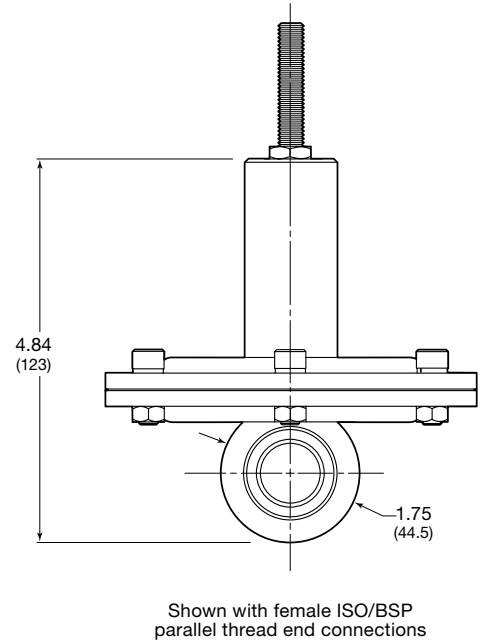
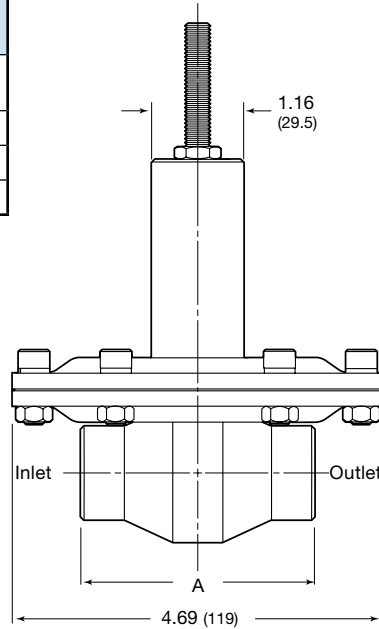

Ordering Information

Build a TBRS4 series regulator ordering number by combining the designators in the sequence shown below.

1 2 3 4 5 6 7 8 9 10 11
TBRS FA 4 A 1 02 - 3 - T T F - G93

1 Series

TBRS = 87.0 psig (6.0 bar) maximum inlet pressure

2 Inlet /Outlet

B = Female ISO/BSP parallel thread
FA = ASME B16.5 flange
FD = DIN flange
TC = Sanitary clamp (BSOD)

3 Size

4 = 1/2 in. / DN15

4 Pressure Class

Omit designator if flanges are not ordered.

A = ASME class 150
M = DN class PN16

5 Flange Facing

Omit designator if flanges are not ordered.
 1 = Raised face smooth

6 Body Material

02 = 316L SS

7 Pressure Control Range

3 = 0.72 to 1.4 psig (20 to 40 in. H₂O, 50 to 100 mbar)
4 = 0.72 to 2.9 psig (20 to 80 in. H₂O, 50 to 200 mbar)
5 = 0.72 to 7.2 psig (20 to 200 in. H₂O, 50 to 500 mbar)
6 = 0.72 to 11.6 psig (20 to 321 in. H₂O, 50 to 800 mbar)

8 Seal Material

T = PTFE

9 Diaphragm Material

T = PTFE

10 Seat Seal Material

F = Kalrez 6230

11 Options

G93 = ASTM G93 Level C-cleaned