

Emergency pressure relief valve

PROTEGO® ER-V-LP

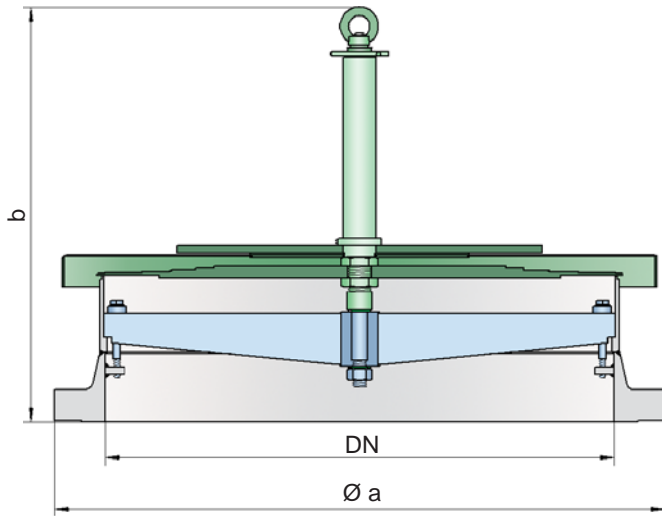

Pressure Settings:

+3.4 mbar up to +15 mbar
 +1.4 inch W.C. up to +6 inch W.C.

For higher pressure settings, see types ER/V, ER/VH and ER/V-F.

Function and Description

The PROTEGO® Type ER-V-LP valve is a sophisticated pressure relief valve for applications in which a high flow efficiency is of the essence. It is primarily used as an emergency pressure relief valve on storage tanks, vessels, silos, and process engineering equipment; it offers reliable protection against excessive overpressure and prevents excessive product loss at pressures as high as close to the set-to-operate pressure. It is designed to relieve particularly large quantities to prevent the vessel rupturing in an emergency case.

The valve will start to open as soon as the set-to-operate pressure is reached and only requires a 10% pressure increase or opening pressure differential until full lift. Dedicated R & D investments have enabled PROTEGO® to develop a new *valve pallet technology* for which a patent has been granted. This patented *valve pallet technology* allows the area characteristic typical of safety valves to be also applied to lower-pressure applications, while ensuring that minimum leakage-rate requirements are met.

Adopting this new patented *valve pallet technology* permits the valve to be set to just 10% below the maximum allowable working pressure of the tank and still vent the required mass flow.

Due to the sophisticated manufacturing technology, the tank pressure is maintained up to the set-to-operate pressure, with seal-tight requirements far above common standards being met. Once the excess pressure is relieved, the valve reseats and seals tight again.

Special Features and Advantages

- patented *valve pallet technology* guarantees that minimum leakage-rate requirements can be met and, hence, least possible product losses and reduced impact on the environment are ensured
- 10% Technology for minimum pressure increase until full lift
- set-to-operate pressure close to the opening pressure; hence, best possible pressure management of the system
- high flow efficiency
- valve pallet is guided within a closed system and, thus, protected from atmospheric influence
- suited for use in hazardous areas
- rugged body design
- movable components are secured
- best technology for API tanks

Design Types and Specifications

The valve pallet is weight-loaded. Higher set-to-operate pressures are achieved with Types ER/V and ER/VH (lever-operated) valves or Type ER/V-F (spring-loaded) valves.

Pressure valve in basic design

ER-V-LP

Additional special devices available upon request

Table 1: Dimensions

Dimensions in mm / inches

To select the nominal size (DN), use the flow capacity chart on the following page

DN	200 / 8"	250 / 10"	300 / 12"	350 / 14"	400 / 16"	450 / 18"	500 / 20"	600 / 24"	700 / 28"
a	343 / 13.50	406 / 15.98	483 / 19.02	533 / 20.98	597 / 23.50	635 / 25.00	699 / 27.52	813 / 32.01	837 / 32.95
b	378 / 14.88	399 / 15.71	409 / 16.10	440 / 17.32	455 / 17.91	464 / 18.27	481 / 18.94	556 / 21.89	571 / 22.48

Table 2: Material selection

Design	A	B	Special Materials upon request
Housing	Steel	Stainless Steel	
Valve seat	Stainless Steel	Stainless Steel	
Valve pallet	Stainless Steel	Stainless Steel	
Sealing	Stainless Steel	Stainless Steel	

Table 3: Flange connection type

EN 1092-1; Form B1	other types upon request
ASME B16.5; 150 lbs RFSF	

Flow Capacity Chart

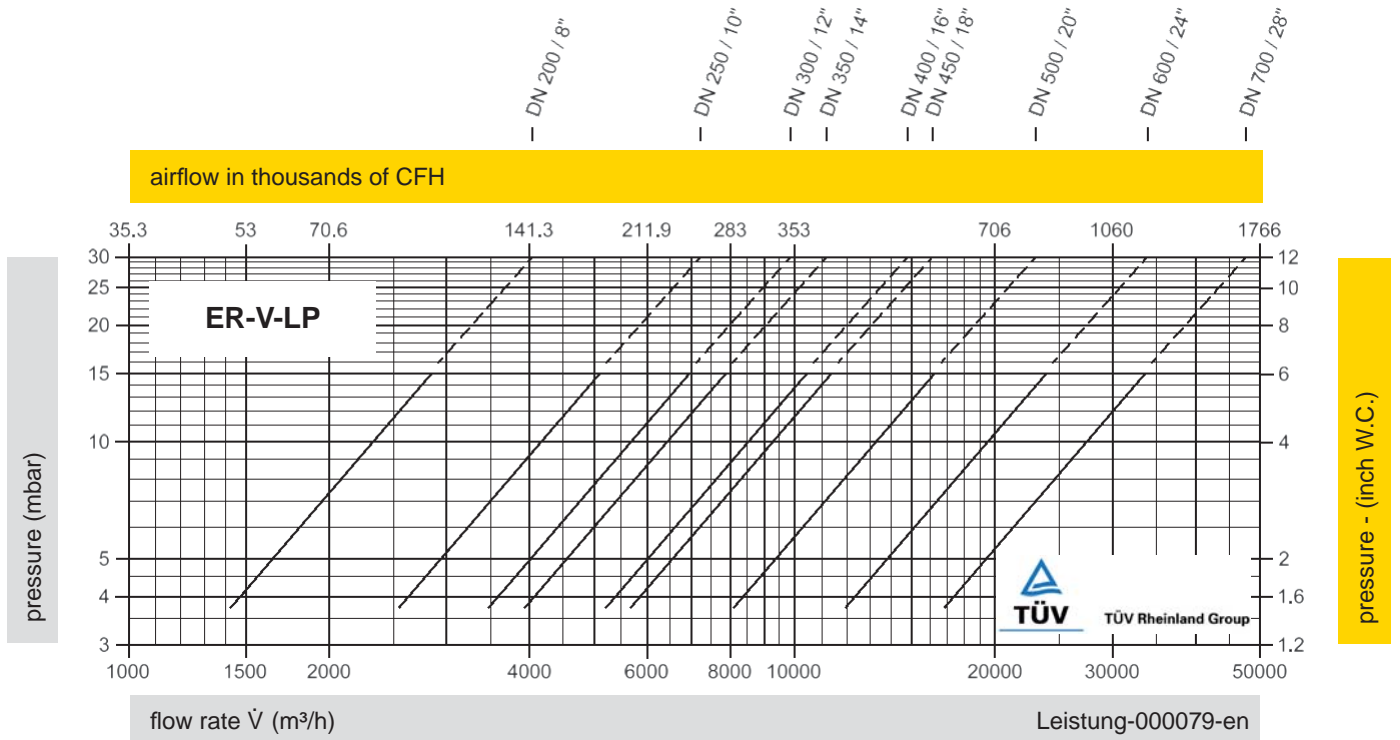

The flow capacity chart has been determined with a calibrated and TÜV certified flow capacity test rig. Volume flow \dot{V} in (m³/h) and CFH refer to the standard reference conditions of air ISO 6358 (20°C, 1bar). Conversion to other densities and temperatures refer to Vol. 1: "Technical Fundamentals".

