

Rosemount™ 2130 Level Switch

Vibrating Fork



NOTICE

This installation guide provides basic guidelines for the Rosemount 2130. It does not provide instructions for detailed configuration, diagnostics, maintenance, service, troubleshooting, or installations. Refer to the Rosemount 2130 [Reference Manual](#) for more instruction. Manuals are available electronically on Emerson.com/Rosemount

⚠ WARNING**Failure to follow these installation guidelines could result in death or serious injury.**

- The Rosemount 2130 Vibrating Fork Level Switch (“level switch”) must be installed, connected, commissioned, operated, and maintained by suitably qualified personnel only, observing any national and local requirements that may apply.
- Ensure the wiring is suitable for the electrical current and the insulation is suitable for the voltage, temperature, and environment.
- Use the equipment only as specified. Failure to do so may impair the protection provided by the equipment.
- Any substitution of non-recognized parts may jeopardize safety and is under no circumstances allowed.
- The weight of the level switch with a heavy flange and extended fork length may exceed 37 lb (18 kg). A risk assessment is required to be done before carrying, lifting and installing the level switch.

Explosions could result in death or serious injury.

- Installation of the level switch in a hazardous environment must be in accordance with the appropriate local, national, and international standards, codes, and practices. Please review the [Product certifications](#) section for any restrictions associated with a safe installation
- Verify that the operating atmosphere of the level switch is consistent with the appropriate hazardous locations certifications.

External surface may be hot.

- Care must be taken to avoid possible burns.

Process leaks could result in death or serious injury.

- Install and tighten process connectors before applying pressure.
- Do not attempt to loosen or remove process connectors while the level switch is in service.

Electrical shock could cause death or serious injury.

- If the level switch is installed in a high voltage environment and a fault condition or installation error occurs, high voltage may be present on leads and terminals.
- Use extreme caution when making contact with the leads and terminals.
- Make sure that power to the level switch is off while making connections.

1.0 Introduction

1.1 Overview of the Rosemount 2130

The Rosemount 2130 Level Switch (“level switch”) uses vibrating short fork technology, and is suitable for virtually all liquid applications.

The level switch is designed using the principle of a tuning fork.

A piezo-electric crystal oscillates the forks at their natural frequency (~ 1400 Hz). Changes to this frequency are continuously monitored. The frequency of the vibrating fork sensor changes depending on the medium in which it is immersed. The denser the liquid, the lower the frequency.

When used as a low level alarm, the liquid in the tank or pipe drains down past the fork, causing a change of natural frequency that is detected by the electronics and switches the output state to a dry condition. When the level switch is used as a high level alarm, the liquid rises in the tank or pipe, making contact with the fork which then causes the output state to switch to a wet condition.

The level switch continuously performs instrument health diagnostics to self-check the condition of the fork and sensor. These diagnostics can detect damage to the forks including corrosion, internal or external damage to the forks, and breakages to the internal wiring. Any of these conditions will trigger the heartbeat LED to pulse intermittently, followed by the safe handling of the electrical load. The level switch has a heartbeat LED that indicates its operating state. The LED flashes when the switch output is off and is constantly lit when 'on'.

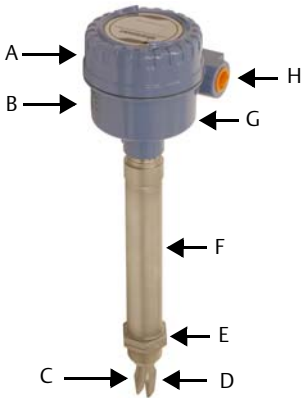
Figure 1. Rosemount 2130 Features

- | | |
|-----------------------------------------------------------------------------------------------------|-------------------------------------------------------|
| A. Direct Load, PLC/PNP, DPCO Relay, Fault + Alarm Relays (2 x SPCO), NAMUR, or 8/16 mA electronics | E. Threaded, flanged, or hygienic process connections |
| B. NEMA® Type 4X (IP66/67) housings in aluminum or 316 SST | F. Thermal tube in 316/316L SST (2130***E only) |
| C. Short fork length with extensions up to 118 in. (3 m), fast drip design | G. Magnetic test point |
| D. Wetted material in 316/316L SST, solid Alloy C and Alloy C-276, or ECTFE/PFA coated 316/316L SST | H. Two cable/conduit entries |

2.0 Before installation

2.1 General considerations

- The weight of the Rosemount 2130 Level Switch (“level switch”) with a heavy flange and extended fork length may exceed 37 lb. (18 kg). A risk assessment is required to be done before carrying, lifting, and installing the level switch.
- Handle the level switch with great care (Figure 2).

Figure 2. Handling the Rosemount 2130

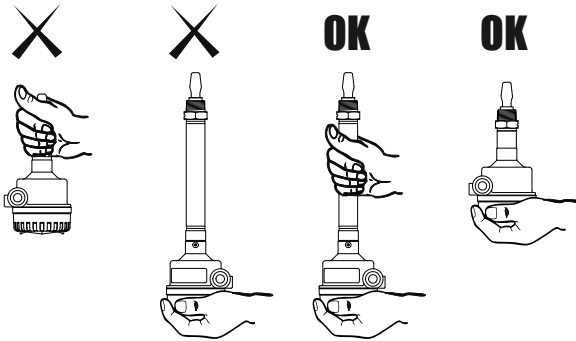

- The level switch is available as intrinsically safe or explosion-proof/flameproof versions for hazardous area installations. See [page 19](#) for approvals. There are ordinary location versions of the level switch for unclassified, safe areas.
- This level switch is designed for open or closed tanks, and pipe installation. It is weatherproof and protected against the ingress of dust, but must be protected from flooding ([Figure 3](#)).
The 2130**E operates in extreme process temperatures of -94 to 500 °F (-70 to 260 °C), and the 2130**M operates in mid-range process temperatures of -40 to 356 °F (-40 to 180 °C).

Figure 3. Environmental Considerations

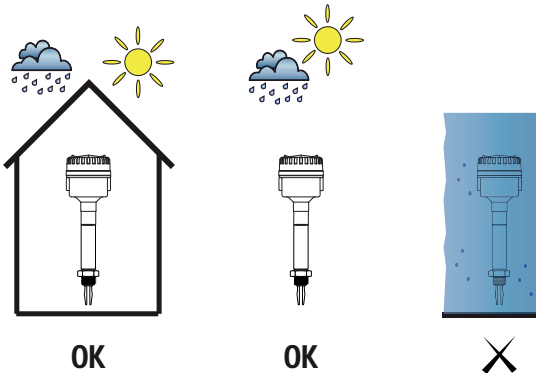

- Ensure there is adequate space outside the tank or pipe. A clearance of 1.2 in. (30 mm) is required for the housing cover to be removed.
- Always ensure a proper seal by installing the electronics housing cover so that metal contacts metal. Use Rosemount O-rings.
- Always ground the housing in accordance with national and local electrical codes. The most effective grounding method is a direct connection to earth (ground) with minimal impedance. Use the fork earth for housings with NPT conduit entries.

2.2 Installation recommendations

- Avoid installing near liquid entering the tank at the fill point.
- Avoid heavy splashing on forks. Increasing time delay reduces accidental switching.
- Avoid installing near heat sources.
- Ensure the forks do not come into contact with the tank/pipe wall or fittings.
- Allow a distance between product build-up on the tank wall and the fork (Figure 4).

Figure 4. Avoid Product Build-up

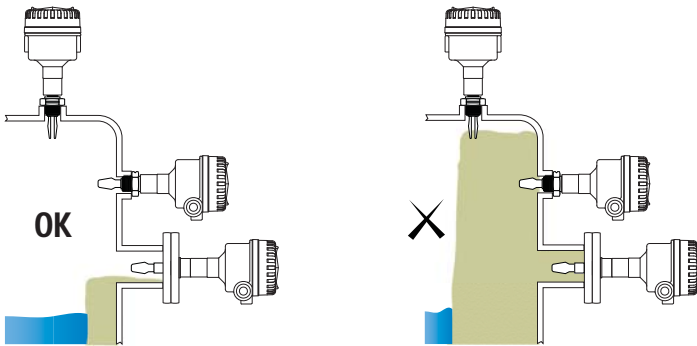



3.0 Physical installation

1. Install the level switch according to standard installation practices, making sure to correctly align the fork using the alignment notch or groove (Figure 5).
2. Use supports for extended fork lengths greater than 3.2 ft. (1 m). Refer to the Rosemount 2130 [Reference Manual](#) for guidance.
3. Close the housing cover and tighten to safety specification. Always ensure a proper seal so that metal touches metal, but do not overtighten.
4. Insulate the level switch with ROCKWOOL®. Refer to the Rosemount 2130 [Reference Manual](#) for guidance.

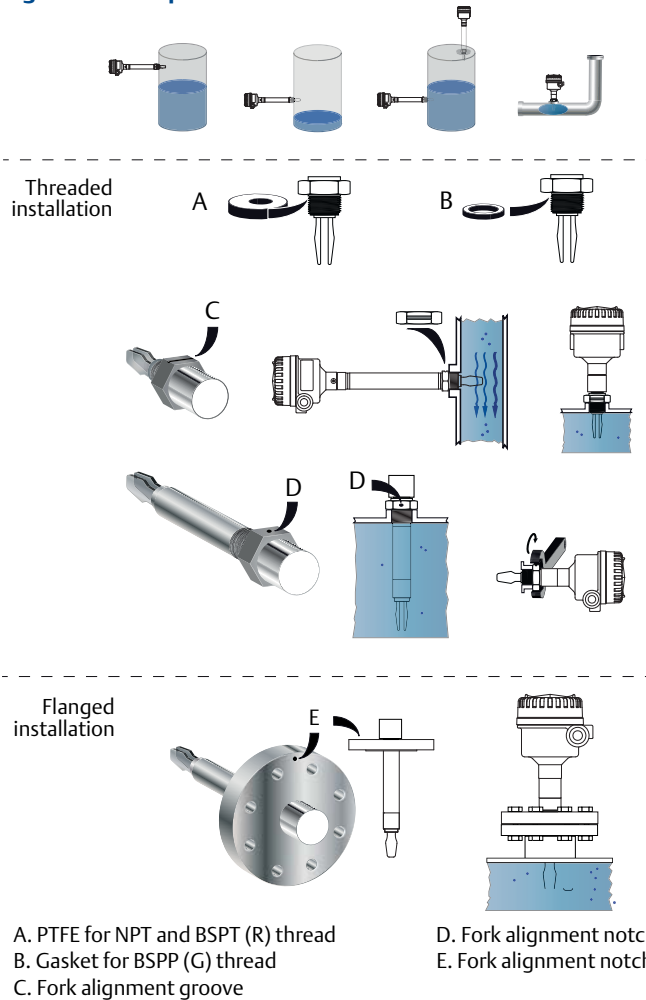
Figure 5. Example Installations



4.0 Electrical installation

-  Before use, check that suitable cable glands and blanking plugs are fitted and fully tightened.
-  Isolate supply before connecting the switch or removing the electronics.
-  The functional earth terminal must be connected to an external earthing system.

4.1 Direct load switching cassette (two-wire, red label)

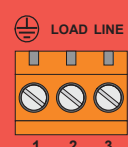

LOAD LINE

1 2 3















PE (Ground)

Fuse 2A(T)

DPST

Neutral Live

0V +V

OPERATION MODE		
Dry On Mode	Dry On	Wet On
Dry 		
Wet 		
Dry 		
Wet 		
Wet On Mode		

Seconds Delay

Direct Load Switching

WARNING 

Isolate Supply Before Removing

R = External load (must be fitted)

U = 20 - 264 V ~ (ac) (50/60Hz)

I_{OFF} < 4 mA

I_L = 20 - 500 mA

I_{PK} = 5 A, 40 ms (inrush)

U = 20 - 60 V ⇄ (dc)







I_{OFF} < 4 mA

I_L = 20 - 500 mA

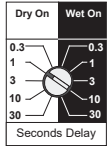
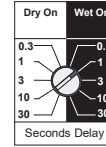
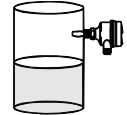
I_{PK} = 5 A, 40 ms (inrush)

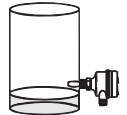
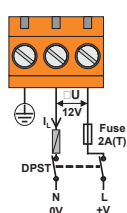
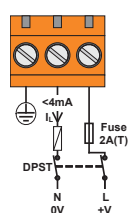
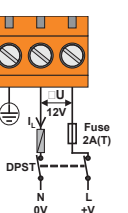
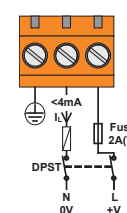
 = Load Off

 = Load On

High level Dry = ON		Low level Wet = ON	
			
			
			
 LED on continuously	 LED flashes each second	 LED on continuously	 LED flashes each second

4.2 PNP/PLC cassette (three-wire, yellow label)

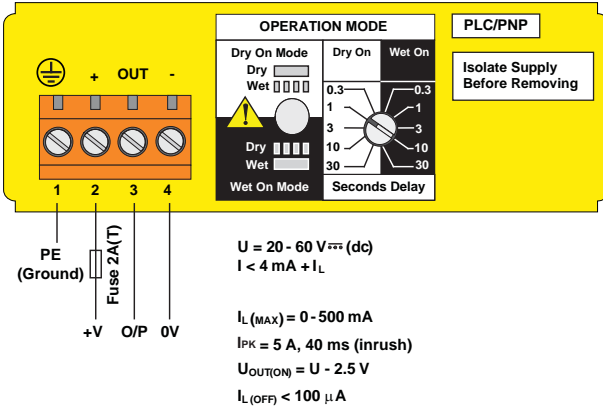

	High level Dry = ON		Low level Wet = ON	
PLC (positive input)				

4.3 DPCO Relay cassette (dark green label)

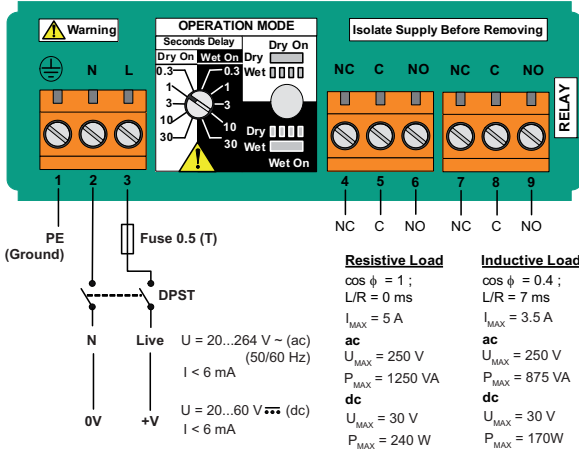

High level Dry = ON		Low level Wet = ON	
<p>Seconds Delay</p>		<p>Seconds Delay</p>	
<p>NC C NO</p>	<p>NC C NO</p>	<p>NC C NO</p>	<p>NC C NO</p>
<p>LED on continuously</p>	<p>LED flashes each second</p>	<p>LED on continuously</p>	<p>LED flashes each second</p>

4.4 Fault and Alarm Relays (2 x SPCO) cassette (light green label)

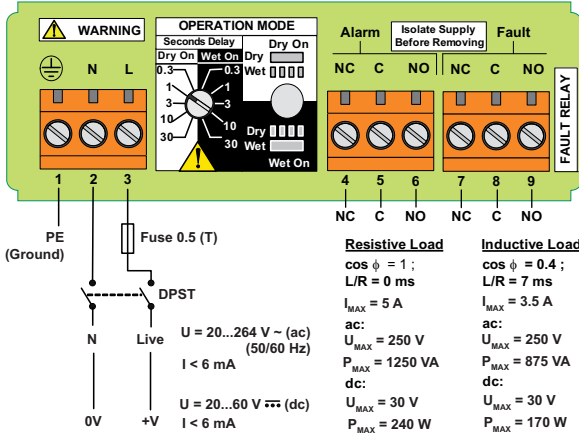

High level Dry = ON				Low level Wet = ON			
<p>Seconds Delay</p>		<p>Seconds Delay</p>					
 (No alarm)	 (No fault)	 (Alarm)	 (No fault)	 (No alarm)	 (No fault)	 (Alarm)	 (No fault)
<p>LED on continuously</p>		<p>LED flashes each second</p>		<p>LED on continuously</p>		<p>LED flashes each second</p>	

4.5 NAMUR cassette (light blue label)

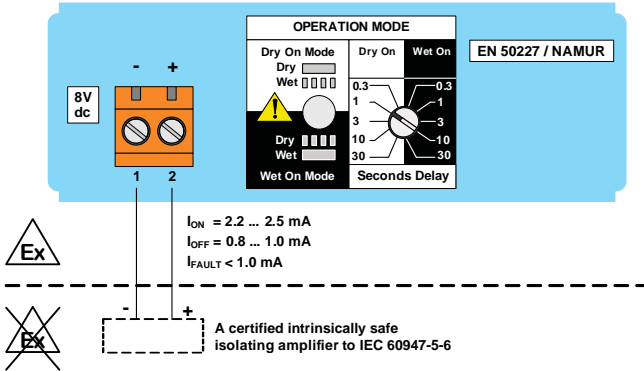

High level Dry = ON		Low level Wet = ON	
LED on continuously	LED flashes each second	LED on continuously	LED flashes each second

Note

This cassette is suitable for intrinsically safe applications and requires an isolating barrier. See “Product certifications” on page 18 for intrinsically safe approvals. This electronics cassette is also suitable for non-hazardous (safe) area applications. It can only be interchanged with the 8/16 mA cassette. Do not exceed 8 Vdc.

4.6 8/16 mA cassette (dark blue label)

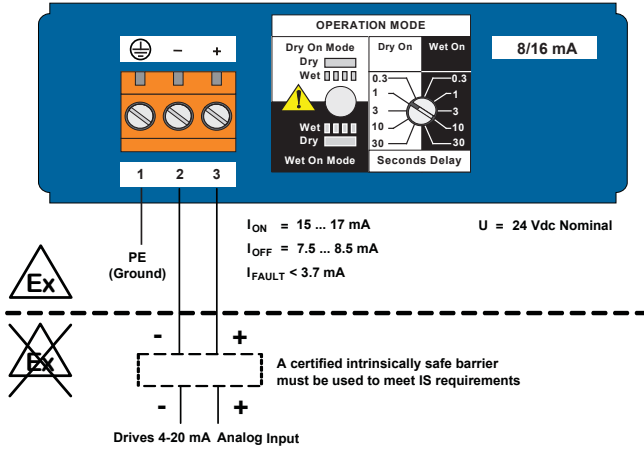

High level Dry = ON		Low level Wet = ON	
<p>> 15 mA</p>	<p>< 8.5 mA</p>	<p>> 15 mA</p>	<p>< 8.5 mA</p>
<p>LED on continuously</p>	<p>LED flashes each second</p>	<p>LED on continuously</p>	<p>LED flashes each second</p>

Note

This cassette is suitable for intrinsically safe applications and requires an isolating barrier. See “[Product certifications](#)” on page 18 for intrinsically safe approvals.

This cassette is also suitable for non-hazardous (safe) area applications. It can only be interchanged with a NAMUR cassette.

4.7 Fault condition detected (self-check mode only)

When a fault condition is detected in the self-check operating mode, the heartbeat LED flashes once every half a second and every third flash is missed. The output from the level switch will then be as follows:

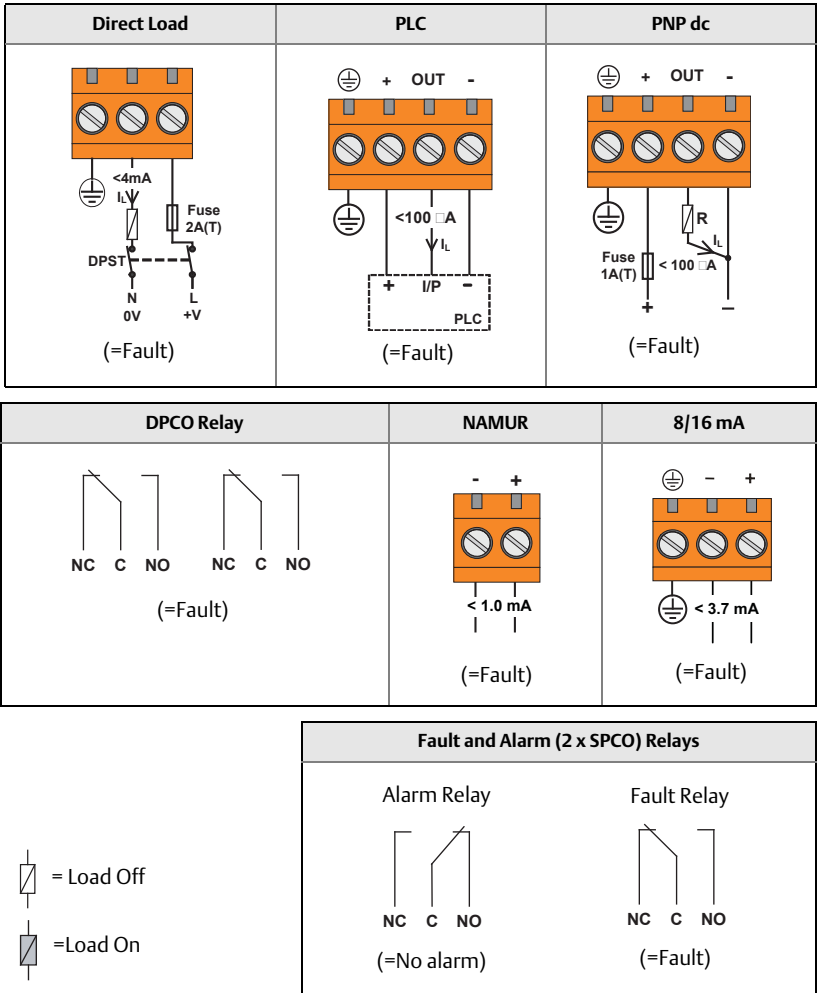

Note

See “LED indication” on page 16 for causes of other LED flashing rates.

5.0 Configuration

5.1 Set the mode switch and switching time delay

1. Select **Dry on** or **Wet on** mode.
2. Select 0.3, 1, 3, 10, or 30 seconds for the delay before switching output state.

Note

There is a five-second delay when changing mode or time delay. The small cut-out in the rotating switch indicates time delay and mode. Recommended installation for a high-level alarm is **Dry on** and for a low-level alarm it is **Wet on**. Do not install in the normally off state.

Figure 6. Top-down View of Example Cassette Inside Housing

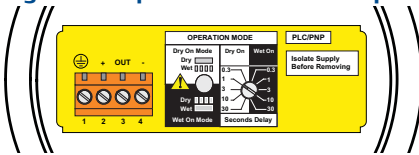

A. LED

B. Mode Switch and Time Delay

5.2 Set the operating mode

Selecting self-check operating mode

When the self-check mode is operating, the heartbeat LED color is yellow.

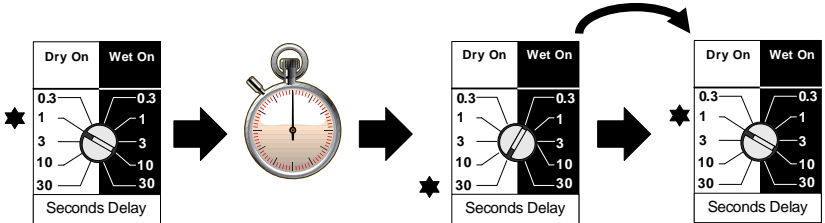

Selecting normal operating mode

When the normal mode is operating, the heartbeat LED color is red.

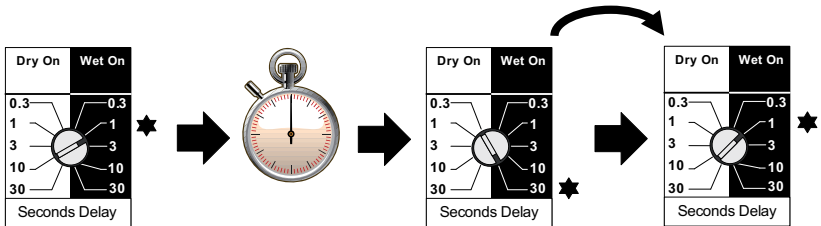

6.0 Verification









6.1 LED indication

Table 1. LED Indication

LED colors	Operating modes ⁽¹⁾	Description of mode
Red	Normal	When the LED is red and flashing, it indicates that the Rosemount 2130 may be uncalibrated, successfully calibrated, has an electrical load problem, or has an internal PCB fault. See Table 2 for further information.
Yellow	Self-check	When the LED is yellow and flashing, it indicates the same as Normal mode and that there could be external damage to forks, corroded forks, or internal sensor damage. See Table 2 for further information.

1. See “Set the operating mode” on page 15.

Table 2. LED Flash Rate

LED flash rate	Switch status
 Continuous	Output state is on
 1 every 1/2 second and every third flash missing	External damage to forks; corroded forks; internal wire damage; internal sensor damage ⁽¹⁾ (Self-check mode only)
 1 every second	Output state is off
 1 every 2 seconds	Uncalibrated ⁽²⁾
 1 every 4 seconds	Load fault; load current too high; load short circuit
 2 times every second	Indication of successful calibration
 3 times every second	Internal PCB fault (microprocessor, ROM, or RAM)
 Off	Problem (e.g. supply)

1. See “Fault condition detected (self-check mode only)” on page 14.

2. Refer to the “Replacement and Calibration of Electronic Cassettes” section in the Rosemount 2130 [Reference Manual](#) or [Manual Supplement](#).

6.2 Magnetic test point

The magnetic test point is on the side of the housing, allowing a functional test of the Rosemount 2130. By touching a magnet on the target, the output changes state for as long as the magnet is held there.

Figure 7. Magnetic Test Point

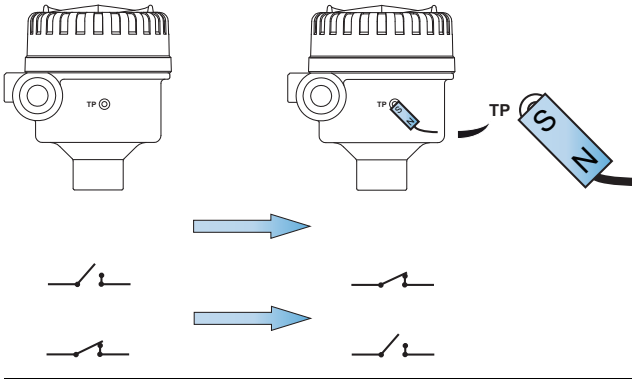

7.0 Troubleshooting

Table 3. Troubleshooting Chart

Fault	Symptom/indication	Action/solution
Does not switch	No LED; no power	Check the power supply; (check load on direct load switching electronics model).
	LED flashing	See “LED indication” on page 16.
	Fork is damaged	Replace the Rosemount 2130.
	Thick encrustation on the forks	Clean the fork with care.
	5 second delay when changing mode/delay	This is normal – wait 5 seconds.
Incorrect switching	Dry = On, Wet = On set correctly	Set the correct mode on the electronics cassette.
Faulty switching	Turbulence	Set a longer switching time delay.
	Excessive electrical noise	Suppress the cause of the interference.
	Cassette has been fitted from another Rosemount 2130.	Fit the factory supplied cassette and then calibrate ⁽¹⁾ .

1. Refer to the “Replacement and Calibration of Electronic Cassettes” section in the Rosemount 2130 [Reference Manual](#) or [Manual Supplement](#).

8.0 Maintenance and inspection

- Use only a damp cloth for cleaning.
- Visually examine the level switch for damage. If it is damaged, do not use it.
- Ensure that the housing cover, cable glands, and blanking plugs are fitted securely.
- Ensure that the LED flash rate is 1 Hz or continually on.
See “LED indication” on page 16.

9.0 Spare parts

- See the Rosemount 2130 [Product Data Sheet](#) for spares and accessories.

10.0 Product certifications

10.1 European Union directive information

The EU declaration of conformity for all applicable European Union directives for this product can be found on [page 33](#) and at Emerson.com/Rosemount.

EN61010-1 Pollution degree 2, Category II (264V max),
Pollution degree 2, Category III (150V max).

10.2 Overfill approval

Certificate number: Z-65.11-519

TÜV-tested and approved for overfill protection according to the German DIBt/WHG regulations. Certified under safety devices for tanks and piping related to water pollution control.

10.3 Marine approvals

ABS American Bureau of Shipping

GL Germanischer Lloyd (excludes Alarm and Fault Relays cassette)

SRS Russian Maritime Registered Shipping (RMRS)

10.4 Drinking water approval

Rosemount Measurement Ltd. (United Kingdom) confirms that the wetted parts of the Rosemount 2130 vibrating fork level switch are suitable and approved for drinking water usage. The wetted parts of the vibrating fork level switches executed in stainless steel (option code S) and Alloy C/Alloy C-276 (option code H) with flanged, NPT thread, BSPT(R) thread, or Tri-clamp process connections, are in accordance with the requirements of DVGW*- Worksheet W270. The materials used are classified as toxicologically and microbiologically safe.

10.5 NAMUR approval

NAMUR NE95 type test is available upon request. Complies with NAMUR NE21.

10.6 Ordinary location certifications

FM ordinary location certification

G5 Project ID: 3021776

The switch has been examined and tested to determine that the design meets basic electrical, mechanical, and fire protection requirements by FM, a nationally recognized testing laboratory (NRTL) as accredited by the Federal Occupational Safety and Health Administration (OSHA).

CSA ordinary location certification

G6 Certificate number 06 CSA 1805769

The switch has been examined and tested to determine that the design meets basic electrical, mechanical, and fire protection requirements by CSA, a nationally recognized testing laboratory as accredited by the Standards Council of Canada (SCC). Single Seal.

10.7 Canadian Registration Number

Certificate number CRN 0F04227.2C

The requirements of CRN are met when a Rosemount 2130 CSA approved vibrating fork level switch (with product certifications code G6, E6, or I6) is configured with stainless steel wetted parts and either NPT threaded or ASME B16.5 2-in. to 8-in. flanged process connections.

10.8 Safety Integrity Level (SIL) certification

The Rosemount 2130 has been independently certified to IEC 61508 as required by IEC 61511. Certification was conducted by Exida. The Rosemount 2130 is SIL2-certified.

10.9 Hazardous locations certificates

Note

A certified isolating amplifier to IEC 60947-5-6 is required for intrinsic safety if the NAMUR electronics is used in a hazardous area installation.

A certified intrinsically safe barrier is required for intrinsic safety if the 8/16 mA electronics is used in a hazardous area installation.

All CSA-approved units are certified per ANSI/ISA 12.27.01-2003.

Control drawings are in the Rosemount 2130 [Reference Manual](#).

North American and Canadian approvals

Factory Mutual (FM) explosion-proof approval

See “Instructions for hazardous area installations (E5 and E6)” on page 23.

E5 Project ID: 3012658

Explosion-proof for Class I, Div. 1, Groups A, B, C, and D

Temperature class: T6 (See Section 10.b on [page 24](#).)

Enclosure: Type 4X

Factory Mutual (FM) intrinsically safe approval

See “Instructions for hazardous area installations (I5 and I6)” on page 25.

- I5** Project ID: 3011456
 Intrinsically safe for Class I, Div. 1, Groups A, B, C, and D
 Class I, Zone 0, AEx ia IIC
 Temperature code: T5 (See Control Drawings.)
 Control drawing: 71097/1154 (*with NAMUR electronics*)
 $U_i=15\text{ V}$, $I_i=32\text{ mA}$, $P_i=0.1\text{ W}$, $C_i=211\text{ nF}$, $L_i=0.06\text{ mH}$
 Control drawing: 71097/1314 (*with 8/16 mA electronics*)
 $U_i=30\text{ V}$, $I_i=93\text{ mA}$, $P_i=0.65\text{ W}$, $C_i=12\text{ nF}$, $L_i=0.035\text{ mH}$
- Canadian Standards Association (CSA) explosion-proof approval**
 See “[Instructions for hazardous area installations \(E5 and E6\)](#)” on page 23.

- E6** Project ID: 1786345
 Explosion-proof for Class I, Div. 1, Groups A, B, C, and D
 Temperature class: T6 (See Section 10.b on page 24.)
 Enclosure: Type 4X
Single Seal

Canadian Standards Association (CSA) intrinsically safe approval
 See “[Instructions for hazardous area installations \(I5 and I6\)](#)” on page 25.

- I6** Certificate number: 06 CSA 1786345
 Intrinsically safe for Class I, Div. 1, Groups A, B, C, and D
 Class I, Zone 0, Ex ia IIC
 Non-incendive for Class I, Div. 2, Groups A, B, C, and D
 Temperature code: T5 (See Control Drawings.)
 Control drawing: 71097/1179 (*with NAMUR electronics*)
 $U_i=15\text{ V}$, $I_i=32\text{ mA}$, $P_i=0.1\text{ W}$, $C_i=211\text{ nF}$, $L_i=0.06\text{ mH}$
 Control drawing: 71097/1315 (*with 8/16 mA electronics*)
 $U_i=30\text{ V}$, $I_i=93\text{ mA}$, $P_i=0.65\text{ W}$, $C_i=12\text{ nF}$, $L_i=0.035\text{ mH}$
Single Seal

Note

A certified isolating amplifier to IEC 60947-5-6 is required for intrinsic safety if the NAMUR electronics is used in a hazardous area installation.

A certified intrinsically safe barrier is required for intrinsic safety if the 8/16 mA electronics is used in a hazardous area installation.

European approvals

ATEX Approvals

- E1** Certificate: Sira 05ATEX1129X
 Flameproof and dust proof:
 ATEX marking II 1/2 GD
 Ex db IIC T6...T2 Ga/Gb
 Ex tb IIIC T85 °C...T265 °C Db
 See “[Instructions specific to hazardous area installations \(E1 / E7\)](#)” on page 27.
- I1** Certificate: Sira 05ATEX2130X
 Intrinsic safety for gas and dust atmospheres:
 ATEX marking  II 1 GD
 Ex ia IIC T5...T2 Ga
 Ex ia IIIC T85 °C...T265 °C Da
 See “[Instructions specific to hazardous area installations \(I1 / I7\)](#)” on page 30.

International approvals

INMETRO approvals

- E2** Certificate number: UL-BR 18.0284X
 Flameproof and dust proof:
 Ex db IIC T6...T2 Ga/Gb, Ex tb IIIC T85°C...T265°C Db
 See specific conditions of use for the temperature class and maximum surface temperature for dust (T**°C) that are applicable to the relevant ambient and process temperatures.
- Specific conditions of use:**
1. The temperature class and the maximum surface temperature for dust (T**°C) are defined by the appropriate ambient temperature and process temperature. See “Temperature” on page 24 for details.
 2. When coated with a non-standard paint, the enclosure is non-conducting and may generate an ignition-capable level of electrostatic charges under certain extreme conditions. The user should ensure that the equipment is not installed in a location where it may be subjected to external conditions, which might cause a build-up of electrostatic charges on non-conducting surfaces. Additionally, cleaning of the equipment should be done only with a damp cloth.
- I2** Certificate number: UL-BR 18.0441X
 Intrinsically Safe for gas and dust atmospheres:
 Ex ia IIC T5...T2 Ga, Ex ia IIIC T85°C...T265°C Da
 See specific conditions of use for the temperature class and maximum surface temperature for dust (T**°C) that are applicable to the relevant ambient and process temperatures.
 Security parameters:
 NAMUR: $U_i = 15 \text{ V} / I_i = 32 \text{ mA} / P_i = 0,1 \text{ W} / C_i = 12 \text{ nF} / L_i = 0,06 \text{ mH}$
 8/16 mA: $U_i = 30 \text{ V} / I_i = 93 \text{ mA} / P_i = 0,65 \text{ W} / C_i = 12 \text{ nF} / L_i = 0,035 \text{ mH}$
- Specific conditions of use:**
1. Under certain extreme circumstances, the non-metallic parts of the equipment may be capable of generating an ignition-capable level of electrostatic charge. The equipment shall only be cleaned with a damp cloth.
 2. The temperature class is defined by the appropriate ambient temperature and the process temperature. See “Temperature” on page 28 for details.

Note

A certified isolating amplifier to IEC 60947-5-6 is required for intrinsic safety if the NAMUR electronics is used in a hazardous area installation.

A certified intrinsically safe barrier is required for intrinsic safety if the 8/16 mA electronics is used in a hazardous area installation.

National Supervision and Inspection Centre for Explosion Protection and Safety Instrumentation (NEPSI) approvals

- E3** Certificate: GYJ101373
 Flameproof and dust proof:
 Ex d IIC T6~T2
 DIP A21 T_A (T85 °C ~ 265 °C) IP6X
 See the certificate or Rosemount 2130 [Reference Manual](#) for instructions specific to hazardous area installations.

- I3** Certificate: GYJ101372X
 Intrinsic safety (NAMUR electronics):
 Ex ia IIC T5~T2
 $U_i=15\text{ V}$, $I_i=32\text{ mA}$, $P_i=0.1\text{ W}$, $C_i=12\text{ nF}$, $L_i=0.06\text{ mH}$
 See the certificate or Rosemount 2130 [Reference Manual](#) for instructions specific to hazardous area installations.

International Electrotechnical Commission (IEC) approvals

- E7** Certificate: IECEx SIR 06.0051X
 Flameproof and dust proof:
 Ex db IIC T6...T2 Ga/Gb
 Ex tb IIIC T85 °C...T265 °C Db
 See “Instructions specific to hazardous area installations (E1 / E7)” on page 27.
- I7** Certificate: IECEx SIR 06.0070X
 Intrinsically safe for gas and dust atmospheres:
 Ex ia IIC T5...T2 Ga
 Ex ia IIIC T85 °C...T265 °C Da
 See “Instructions specific to hazardous area installations (I1 / I7)” on page 30.

Note

A certified isolating amplifier to IEC 60947-5-6 is required for intrinsic safety if the NAMUR electronics is used in a hazardous area installation.

A certified intrinsically safe barrier is required for intrinsic safety if the 8/16 mA electronics is used in a hazardous area installation.

Technical Regulation Customs Union (EAC), flameproof approval

- EM** Certificate: RU C-GB.AB72.B.01385
 (M20 conduit entry/cable thread only)
 Markings for 2130***M:
 1Exd IIC T6 X (-40 °C ≤ Ta ≤ +75 °C);
 1Exd IIC T5 X (-40 °C ≤ Ta ≤ +70 °C);
 1Exd IIC T4 X (-40 °C ≤ Ta ≤ +65 °C);
 1Exd IIC T3 X (-40 °C ≤ Ta ≤ +50 °C)
- Markings for 2130***E:
 1Exd IIC T6 X (-40 °C ≤ Ta ≤ +75 °C);
 1Exd IIC T5 X (-40 °C ≤ Ta ≤ +74 °C);
 1Exd IIC T4 X (-40 °C ≤ Ta ≤ +73 °C);
 1Exd IIC T3 X (-40 °C ≤ Ta ≤ +69 °C);
 1Exd IIC T2 X (-40 °C ≤ Ta ≤ +65 °C)
- See certificate for special conditions for safe use (X).

Technical Regulation Customs Union (EAC), intrinsically safe approval

- IM** Certificate: RU C-GB.AB72.B.01385
 (NAMUR and 8/16 mA electronics only)
 Markings for 2130***M:
 0Exia IIC T5 X (-50 °C ≤ Ta ≤ +80 °C);
 0Exia IIC T4 X (-50 °C ≤ Ta ≤ +69 °C);
 0Exia IIC T3 X (-50 °C ≤ Ta ≤ +50 °C)

Markings for 2130***E:

- 0Exia IIC T5 X (-50 °C ≤ Ta ≤ +80 °C);
- 0Exia IIC T4 X (-50 °C ≤ Ta ≤ +77 °C);
- 0Exia IIC T3 X (-50 °C ≤ Ta ≤ +71 °C);
- 0Exia IIC T2 X (-50 °C ≤ Ta ≤ +65 °C)

See certificate for special conditions for safe use (X).

10.10 Instructions for hazardous area installations (E5 and E6)

Model numbers covered:

- 2130**9E*****E5***, 2130**9E*****E6***
 - 2130**9M*****E5***, 2130**9M*****E6***
- ("*" indicates options in construction, function and materials).

The following instructions apply to equipment covered by CSA and FM explosion-proof approvals:

1. The equipment may be used with flammable gases and vapors with apparatus Class 1, Div 1, Groups A, B, C, and D.
2. CSA and FM explosion-proof approved versions of the **2130***E** are certified for use in ambient temperatures of -58 °F to 167 °F (-50 °C to 75 °C), and with a maximum process temperature of 500 °F (260 °C).
 CSA and FM explosion-proof approved versions of the **2130***M** are certified for use in ambient temperatures of -40 °F to 167 °F (-40 °C to 75 °C), and with a maximum process temperature of 356 °F (180 °C)
3. Installation of this equipment shall be carried out by suitably trained personnel, in accordance with the applicable code of practice.
4. Inspection and maintenance of this equipment shall be carried out by suitably trained personnel, in accordance with the applicable code of practice.
5. The user should not repair this equipment.
6. The certification of this equipment relies upon the following materials used in its construction:

Body: Aluminum alloy (ASTM B85 360.0) or 316 stainless steel

Cover: Aluminum alloy (ASTM B85 360.0) or 316 stainless steel

Probe:

316 stainless steel, or Alloy C276 (UNS N10276) and alloy C (UNS N10002)

Probe Filling: Perlite

Cover Seal: Silicone

If the equipment is likely to come into contact with aggressive substances, it is the responsibility of the user to take suitable precautions that prevent it from being adversely affected, thus ensuring that the type of protection is not compromised.

Aggressive substances – e.g. acidic liquids or gases that may attack metals or solvents that may affect polymeric materials.

Suitable precautions – e.g. regular checks as part of routine inspections or establishing from the material’s data sheet that it is resistant to specific

chemicals.

The metallic alloy used for the enclosure material may be at the accessible surface of this equipment; in the event of rare accidents, ignition sources due to impact and friction sparks could occur. This shall be considered when the Rosemount 2130 is installed in locations that specifically require Class 1, Div 1 equipment.

7. It is the responsibility of the user to ensure:
 - a. The voltage and current limits for this equipment are not exceeded.
 - b. That the joint requirements between the probe (switch) and the vessel tank are compatible with the process media.
 - c. That the joint tightness is correct for the joint material used.
 - d. That only suitably certified cable entry devices will be utilized when connecting this equipment.
 - e. That any unused cable entries are sealed with suitably certified stopping plugs.
8. The probe fork is subjected to small vibration stresses as part of its normal function. As this provides a partition wall, it is recommended that the fork should be inspected every two years for signs of defects.
9. Technical data:
 - a. Coding: Class 1, Div 1, Groups A, B, C, and D
 - b. Temperature

21309E*****E5** , 2130**9E*****E6**:**

Temperature classes	Maximum ambient air temperature (Ta)	Maximum process temperature (Tp)
T6, T5, T4, T3, T2, T1	75 °C	80 °C
T5, T4, T3, T2, T1	74 °C	95 °C
T4, T3, T2, T1	73 °C	125 °C
T3, T2, T1	69 °C	185 °C
T2, T1	65 °C	260 °C

Minimum ambient air temperature (Ta) = -50 °C

Minimum process temperature (Tp) = -70 °C

21309M*****E5** , 2130**9M*****E6**:**

Temperature classes	Maximum ambient air temperature (Ta)	Maximum process temperature (Tp)
T6, T5, T4, T3, T2, T1	75 °C	75 °C
T5, T4, T3, T2, T1	70 °C	90 °C
T4, T3, T2, T1	65 °C	125 °C
T3, T2, T1	50 °C	180 °C

Minimum ambient air temperature (Ta) = -40 °C

Minimum process temperature (Tp) = -40 °C

- c. Pressure: Must not exceed the rating of the coupling/flange fitted.
- d. For electrical details and pressure ratings, see the Rosemount 2130 [Product Data Sheet](#) or [Reference Manual](#).
- e. Year of manufacture: printed on product label.

10. Cable selection:

- a. It is the responsibility of the user to ensure that suitably temperature rated cable is used. The table below is a guide to selection:

T class	Cable temperature rating
T6	Above 185 °F (85 °C)
T5	Above 212 °F (100 °C)
T4	Above 275 °F (135 °C)
T3	Above 320 °F (160 °C)

10.11 Instructions for hazardous area installations (I5 and I6)

Model numbers covered:

2130N*******I5*****, 2130N*******I6*****
 2130M*******I5*****, 2130M*******I6*****
 (“*” indicates options in construction, function and materials).

The following instructions apply to equipment covered by CSA and FM intrinsically safe and non-incendive approvals:

1. The intrinsically safe approved Rosemount 2130 may be used in hazardous locations with flammable gases and vapors Class 1 Division 1 Groups A, B, C, and D, and Class 1 Zone 0 Group IIC when installed in accordance with control drawings 71097/1154, 71097/1314, 71097/1179, or 71097/1315. Control drawings are in the Rosemount 2130 [Reference Manual](#).
2. The non-incendive approved Rosemount 2130 may be used in hazardous locations with flammable gases and vapors Class 1 Division 2 Groups A, B, C, and D when installed in accordance with Control Drawing 71097/1179 or 71097/1315. Control drawings are in the Rosemount 2130 [Reference Manual](#).
3. The apparatus electronics is only certified for use in ambient temperatures in the range of -50 to 80 °C. It should not be used outside this range. However, the switch may be located in the process medium which may be at a higher temperature than the electronics but must not be higher than the Temperature Class for the respective process gas/medium.
4. It is a condition of the approval that the electronics temperature is in the range of -58 to 176 °F (-50 to 80 °C). It must not be used outside this range. It will be necessary to limit the external ambient temperature if the process temperature is high.
5. Suitably trained personnel shall carry out installation in accordance with the applicable code of practice.
6. The user should not repair this equipment.

7. If the equipment is likely to come into contact with aggressive substances, it is the responsibility of the user to take suitable precautions that prevent it from being adversely affected, thus ensuring that the type of protection is not compromised.

Aggressive substances – e.g. acidic liquids or gases that may attack metals or solvents that may affect polymeric materials.

Suitable precautions – e.g. regular checks as part of routine inspections or establishing from the material's data sheet that it is resistant to specific chemicals.

8. If the enclosure is made of an alloy or plastic material, the following precautions must be observed:
 - a. The metallic alloy used for the enclosure material may be at the accessible surface of this equipment; in the event of rare accidents, ignition sources due to impact and friction sparks could occur.
 - b. Under certain extreme circumstances, the non-metallic parts incorporated in the enclosure of the Rosemount 2130 may generate an ignition-capable level of electrostatic charge. Therefore, when they are used for applications that specifically require group II equipment, the Rosemount 2130 shall not be installed in a location where the external conditions are conducive to the build-up of electrostatic charge on such surfaces. Additionally, the Rosemount 2130 shall only be cleaned with a damp cloth.
9. Technical data:
 - a. I.S. approval: Class 1 Division 1 Groups A, B, C, and D, Class 1 Zone 0 AEx ia IIC
Non-incendive Approval: Class 1 Division 2 Groups A, B, C, and D
 - b. Input parameters:
Rosemount 2130 with NAMUR electronics:
 $V_{max}=15\text{ V}$, $I_{max}=32\text{ mA}$, $P_i=0.1\text{ W}$, $C_i=211\text{ nF}$, $L_i=0.06\text{ mH}$
Rosemount 2130 with 8/16 mA electronics:
 $V_{max}=30\text{ V}$, $I_{max}=93\text{ mA}$, $P_i=0.65\text{ W}$, $C_i=12\text{ nF}$, $L_i=0.035\text{ mH}$
 - c. Materials: see the Rosemount 2130 [Product Data Sheet](#).
 - d. Year of manufacture: printed on product label.

10.12 Instructions specific to hazardous area installations (E1 / E7)

Model numbers covered:

2130*A2E*****E1****, 2130*S2E*****E1****,
 2130*A2E*****E7****, 2130*S2E*****E7****,
 2130*A2M*****E1****, 2130*S2M*****E1****,
 2130*A2M*****E7****, 2130*S2M*****E7****
 (“*” indicates options in construction, function and materials).

The following instructions apply to the equipment covered by certificates **Sira 05ATEX1129X** and **IECEX SIR 06.0051X**:

1. The equipment may be used with flammable gases and vapors with apparatus groups IIA, IIB, and IIC, and with temperature classes T1, T2, T3, T4, T5, and T6
 [IECEX: in Zones 1 and 2. The probe may be installed into a Zone 0 vessel].
 The temperature class of the installation will be determined from the higher of the process or ambient temperature.
2. The equipment may be used with explosive dusts with apparatus groups IIIC, IIIB, and IIIA. The maximum surface temperature of the installation will be determined from the higher of the process or ambient temperature.
3. The equipment is suitable for installation across the boundary between an area that specifically requires Equipment Protection Level Ga (Zone 0) and an area that specifically requires Equipment Protection Level Gb or Db (Zone 1 or 21). The probe forks (and extension tube) only to be installed in Zone 0.
4. The equipment has not been assessed as a safety related device [ATEX: as referred to by Directive 94/9/EC (2014/34/EU) Annex II, clause 1.5].
5. Installation of this equipment shall be carried out by suitably trained personnel, in accordance with the applicable code of practice.
6. Inspection and maintenance of this equipment shall be carried out by suitably trained personnel, in accordance with the applicable code of practice.
7. The user should not repair this equipment. Repair or modification of flamepaths is not permitted.
8. The certification of this equipment relies upon the following materials used in its construction:

Body & lid: Aluminum alloy (ASTM B85 360.0) or stainless steel 316L type
Housing and cover: Aluminum alloy (ASTM B85 A360.0) or stainless steel 316C12.

Probe: Stainless steel 316 type, or alloy C (UNS N10002) and alloy C-276 (UNS N10276)

Partition wall: Stainless steel 316L or 316/316L, or alloy C275 (UNS N10276) and alloy C (UNS N10002 or N30002).

Probe filling: Perlite

Seals: Silicone

- 9. If the equipment is likely to come into contact with **aggressive substances**, it is the responsibility of the user to take **suitable precautions** that prevent it from being adversely affected, thus ensuring that the type of protection is not compromised.

Aggressive substances: e.g. acidic liquids or gases that may attack metals, or solvents that may affect polymeric materials

Suitable precautions: e.g. regular checks as part of routine inspections or establishing from the material’s data sheet that it is resistant to specific chemicals

- 10. It is the responsibility of the user to ensure:
 - a. The voltage and current limits for this equipment are not exceeded.
 - b. That the joint requirements between the probe (switch) and the vessel tank are compatible with the process media.
 - c. That the joint tightness is correct for the joint material used.
 - d. That only suitably certified cable entry devices will be utilized when connecting this equipment.
 - e. That any unused cable entries are sealed with suitably certified stopping plugs.
- 11. The probe fork is subjected to small vibration stresses as part of its normal function. As this provides a partition wall, it is recommended that the fork should be inspected every 2 years for signs of defects.

12. Technical data:

- a. Coding:
ATEX:
 Certificate: Sira 05ATEX1129X
 Flameproof and dust proof:
 ATEX marking II 1/2 GD
 Ex db IIC T6...T2 Ga/Gb
 Ex tb IIIC T85 °C...T265 °C Db
IECEX:
 Ex d IIC T6...T2 Ga/Gb
 Ex tb IIIC T85 °C...T265 °C Db

- b. Temperature
2130 *A2E***E1****, 2130 *S2E*****E1****, 2130 *A2E*****E7**** and 2130 *S2E*****E7****:**

Temperature Classes	Maximum Surface Temperature (T)	Maximum Ambient Air Temperature (Ta)	Maximum Process Temperature (Tp)
T6, T5, T4, T3, T2, T1	T85 °C	75 °C	80 °C
T5, T4, T3, T2, T1	T100 °C	74 °C	95 °C
T4, T3, T2, T1	T120 °C	73 °C	115 °C
T3, T2, T1	T190 °C	69 °C	185 °C
T2, T1	T265 °C	65 °C	260 °C

Minimum ambient air temperature (Ta) = -40 °C
 Minimum process temperature (Tp) = -70 °C

2130*A2M***E1****, 2130*S2M*****E1****,
 2130*A2M*****E7**** and
 2130*S2M*****E7****:**

Temperature Classes	Maximum Surface Temperature (T)	Maximum Ambient Air Temperature (Ta)	Maximum Process Temperature (Tp)
T6, T5, T4, T3, T2, T1	T85 °C	75 °C	75 °C
T5, T4, T3, T2, T1	T100 °C	70 °C	90 °C
T4, T3, T2, T1	T135 °C	65 °C	125 °C
T3, T2, T1	T190 °C	50 °C	180 °C

Minimum ambient air temperature (Ta) = -40 °C

Minimum process temperature (Tp) = -40 °C

- c. Pressure: Must not exceed the rating of the coupling/flange fitted.
 - d. For electrical details and pressure ratings, see the Rosemount 2130 [Product Data Sheet](#) or the [Reference Manual](#).
 - e. Year of manufacture: printed on product label.
13. Cable selection
- a. It is the responsibility of the user to ensure that suitably temperature rated cable is used. The table below is a guide to selection:

Note

The cable entry temperature may exceed 70°C.

T Class	Cable Temperature Rating
T6	Above 85 °C
T5	Above 100 °C
T4	Above 135 °C
T3	Above 190 °C

14. Special conditions of use:
- a. The user is to ensure the probe assembly is installed in such a way to prevent any damage due to impact or ignition source due to friction.
 - b. Under certain extreme circumstances, a non-standard paint on the enclosure of the Rosemount 2130 may generate an ignition-capable level of electrostatic charge. Therefore the Rosemount 2130 shall not be installed in a location where the external conditions are conducive to the build-up of electrostatic charge on such surfaces. Additionally, the Rosemount 2130 shall only be cleaned with a damp cloth.
 - c. The user is to ensure the ambient air temperature (Ta) and the process temperature (Tp) are within the range detailed above for the T class of the specific flammable gases or vapors present.
 - d. The user is to ensure the ambient air temperature (Ta) and the process temperature (Tp) are within the range detailed above for the maximum surface temperature of the specific flammable dusts present.

15. Manufacturer:

Rosemount Measurement Limited
 158 Edinburgh Avenue, Slough, Berkshire, SL1 4UE, United Kingdom.

10.13 Instructions specific to hazardous area installations (11 / 17)

Model numbers covered:

2130M**E*******I1******, 2130M**M*******I1******,
 2130M**E*******I7******, 2130M**M*******I7******,
 2130N**E*******I1******, 2130N**M*******I1******,
 2130N**E*******I7******, 2130N**M*******I7******

("*" indicates options in construction, function, and materials).

The following instructions apply to the equipment covered by certificates **Sira 05ATEX2130X** and **IECEx SIR 06.0070X**:

1. The Intrinsically Safe (I.S.) approved version of the 2130 may be used in a hazardous area with explosive gases and vapors with apparatus groups IIC, IIB, and IIA, and with temperature classes T1, T2, T3, T4, and T5 [**IECEx**: in Zone 0, 1, and 2].
 The temperature class of the installation will be determined from the higher of the process or ambient temperature.
2. The equipment may be used in a hazardous area with explosive dusts with apparatus groups IIIC, IIIB, and IIIA [**IECEx**: in Zones 20, 21, and 22].
3. It is a special condition of the certification that the temperature of the electronics housing is in the range of –50 to 80 °C.
 It must not be used outside this range. It will be necessary to limit the external ambient temperature if the process temperature is high.
 See also "Technical data" below.
4. Suitably trained personnel shall carry out installation in accordance with the applicable code of practice.
5. The user should not repair this equipment.
6. If the equipment is likely to come into contact with **aggressive substances**, it is the responsibility of the user to take **suitable precautions** that prevent it from being adversely affected, thus ensuring that the type of protection is not compromised.
 Aggressive Substances: e.g. acidic liquids or gases that may attack metals or solvents that may affect polymeric materials.
 Suitable Precautions: e.g. regular checks as part of routine inspections or establishing from the material's data sheet that it is resistant to specific chemicals.
7. The Rosemount 2130 meets the requirements of clause 6.3.12 (Isolation of circuits from earth or frame) in EN 60079-11 (IEC 60079-11).
8. Technical data:
 - a. Coding:
ATEX:
 Certificate: Sira 05ATEX2130X
 Intrinsic safety for gas and dust atmospheres:
 ATEX marking  II 1 GD
 Ex ia IIC T5...T2 Ga, Ex ia IIIC T85 °C...T265 °C Da
IECEx:
 Ex ia IIC T5...T2 Ga, Ex ia IIIC T85 °C...T265 °C Da

b. Temperature:

2130NE*****I1**** and 2130N**E*****I7****:**

Gas (Ga) and Dust (Da)			
Temperature Classes	Maximum Surface Temperature (T)	Maximum Ambient Air Temperature (Ta)	Maximum Process Temperature (Tp)
T5, T4, T3, T2, T1	T85 °C	80 °C	80 °C
T4, T3, T2, T1	T120 °C	77 °C	115 °C
T3, T2, T1	T190 °C	71 °C	185 °C
T2, T1	T265 °C	65 °C	260 °C

Minimum ambient air temperature (Ta) = -50 °C

Minimum process temperature (Tp) = -70 °C

2130NM*****I1**** and**

2130NM*****I7****:**

Gas (Ga) and Dust (Da)			
Temperature Classes	Maximum Surface Temperature (T)	Maximum Ambient Air Temperature (Ta)	Maximum Process Temperature (Tp)
T5, T4, T3, T2, T1	T85 °C	80 °C	80 °C
T4, T3, T2, T1	T120 °C	69 °C	115 °C
T3, T2, T1	T185 °C	50 °C	180 °C

Minimum ambient air temperature (Ta) = -50 °C

Minimum process temperature (Tp) = -40 °C

2130ME*****I1**** and 2130M**E*****I7****:**

Temperature Classes	Gas (Ga)		Dust (Da)		
	Maximum Ambient Air Temperature (Ta)	Maximum Process Temperature (Tp)	Maximum Surface Temperature (T)	Maximum Ambient Air Temperature (Ta)	Maximum Process Temperature (Tp)
T5, T4, T3, T2, T1	80 °C	80 °C	T85 °C	70 °C	80 °C
T4, T3, T2, T1	77 °C	115 °C	T120 °C	70 °C	115 °C
T3, T2, T1	71 °C	185 °C	T190 °C	70 °C	185 °C
T2, T1	65 °C	260 °C	T265 °C	65 °C	260 °C

Minimum ambient air temperature (Ta) = -50 °C

Minimum process temperature (Tp) = -70 °C

2130M**M*****I1*** and
 2130M**M*****I7***:

Gas (Ga)			Dust (Da)		
Temperature Classes	Maximum Ambient Air Temperature (Ta)	Maximum Process Temperature (Tp)	Maximum Surface Temperature (T)	Maximum Ambient Air Temperature (Ta)	Maximum Process Temperature (Tp)
T5, T4, T3, T2, T1	80 °C	80 °C	T85 °C	70 °C	80 °C
T4, T3, T2, T1	69 °C	115 °C	T120 °C	69 °C	115 °C
T3, T2, T1	50 °C	180 °C	T185 °C	50 °C	180 °C

Minimum ambient air temperature (Ta) = -50 °C

Minimum process temperature (Tp) = -40 °C

- c. Input parameters:
 Rosemount 2130 with NAMUR electronics:
 Vmax=15 V, Imax=32 mA, Pi=0.1 W, Ci=12 nF, Li=0.06 mH
 Rosemount 2130 with 8/16 mA electronics:
 Vmax=30 V, Imax=93 mA, Pi=0.65 W, Ci=12 nF, Li=0.035 mH
- d. Materials: see the Rosemount 2130 [Product Data Sheet](#).
- e. Year of manufacture: printed on product label.

9. Special conditions of use:

- a. If the enclosure is made of an alloy or plastic material, the following precautions must be observed:
 - (i) The metallic alloy used for the enclosure material may be at the accessible surface of this equipment; in the event of rare accidents, ignition sources due to impact and friction sparks could occur. This shall be considered when the Rosemount 2130 is being installed in locations that specifically require Equipment Protection Level Ga or Da [**ATEX:** group II, category 1G or 1D equipment] [**IECEX:** in Zone 0 or 20 locations].
 - (ii) Under certain extreme circumstances, the non-metallic parts incorporated in the enclosure of the Rosemount 2130 may generate an ignition-capable level of electrostatic charge. Therefore, when they are used for applications that specifically require Equipment Protection Level Ga or Da [**ATEX:** group II, category 1G or 1D equipment] [**IECEX:** in Zone 0 or 20 locations], the Rosemount 2130 shall not be installed in a location where the external conditions are conducive to the build-up of electrostatic charge on such surfaces. Additionally, the Rosemount 2130 shall only be cleaned with a damp cloth.
- b. Ensure the ambient air temperature (Ta) and the process temperature (Tp) are within the range detailed above for the T class of the specific explosive gases or vapors present.
- c. Ensure the ambient air temperature (Ta) and the process temperature (Tp) are within the range detailed above for the maximum surface temperature of the specific explosive dusts present.

Figure 8. EU Declaration of Conformity for Rosemount 2130 (Page 1)



	<h2 style="margin: 0;">EU Declaration of Conformity</h2> <p style="margin: 0;">No: RMD 1075 Rev. J</p>	
<p>We,</p> <p style="margin-left: 40px;">Rosemount Measurement Limited 158 Edinburgh Avenue Slough, Berkshire, SL1 4UE United Kingdom</p> <p>declare under our sole responsibility that the product,</p> <p style="text-align: center;">Rosemount™ 2130 Series Vibrating Fork Liquid Level Switch</p> <p>manufactured by,</p> <p style="margin-left: 40px;">Rosemount Measurement Limited 158 Edinburgh Avenue Slough, Berkshire, SL1 4UE United Kingdom</p> <p>to which this declaration relates, is in conformity with the provisions of the European Union Directives, including the latest amendments, as shown in the attached schedule.</p> <p>Assumption of conformity is based on the application of the harmonized standards and, when applicable or required, a European Union notified body certification, as shown in the attached schedule.</p>		
 _____ (signature)	_____ Technical Director (function)	
_____ Timothy Hill (name)	_____ 7/05/2019; Slough, GB (date of issue & place)	
Page 1 of 4		en

Figure 9. EU Declaration of Conformity for Rosemount 2130 (Page 2)



	EU Declaration of Conformity No: RMD 1075 Rev. J	
EMC Directive (2014/30/EU)		
Rosemount 2130N***** (Namur cassette) Harmonized Standards: EN 61326-1:2013; EN 61326-2-3:2013; EN 60947-5-6:2001 Other Standards used: EN 61326-3-1:2008		
Rosemount 2130D***** (Relay Mains cassette) Rosemount 2130P***** (PNP/PLC cassette) Rosemount 2130M***** (8/16mA cassette) Rosemount 2130F***** (Fault Relay cassette) Harmonized Standards: EN 61326-1:2013; EN 61326-2-3:2013 Other Standards used: EN 61326-3-1:2008		
Rosemount 2130L***** (Direct Load cassette) Harmonized Standards: EN 61326-1:2013; EN 61326-2-3:2013		
LV Directive (2014/35/EU)		
Rosemount 2130D***** (Relay Mains cassette) Rosemount 2130L***** (Direct Load cassette) Rosemount 2130F***** (Fault Relay cassette) Harmonized Standards: EN 61010-1:2010		
Page 2 of 4 en		

Figure 10. EU Declaration of Conformity for Rosemount 2130 (Page 3)



	<h2 style="margin: 0;">EU Declaration of Conformity</h2>	
<p>No: RMD 1075 Rev. J</p>		
<p>ATEX Directive (2014/34/EU)</p>		
<p>Rosemount 2130N*****II* (Namur cassette)</p>		
<p>Rosemount 2130M*****I1* (8/16mA cassette)</p>		
<p>Sira 05ATEX2130X – Intrinsically safe (Gas & Dust)</p>		
<p>Equipment Group II, Category 1 GD</p>	<p>Ex ia IIC T5...T2 Ga</p>	<p>Ex ia IIIC T85°C...T265°C Da</p>
<p>Harmonized Standards: EN 60079-0:2012/A11:2013; EN 60079-26:2007; EN 60079-26:2015</p>		
<p>Rosemount 2130N*****I8*; Rosemount 2130N*****I1*R2364 (Namur cassette)</p>		
<p>Rosemount 2130M*****I8*; Rosemount 2130M*****I1*R2634 (8/16mA cassette)</p>		
<p>Sira 05ATEX2130X – Intrinsically safe (Gas & Dust)</p>		
<p>Equipment Group II, Category 1/2G</p>	<p>Ex ib IIC T5...T2 Ga/Gb</p>	<p>Ex ib IIIC T85°C...T265°C Db</p>
<p>Equipment Group II, Category 2D</p>	<p>Harmonized Standards: EN 60079-0:2012/A11:2013; EN 60079-26:2007; EN 60079-26:2015</p>	
<p>Rosemount 2130*A2*****E1*; Rosemount 2130*S2*****E1* (All cassettes, M20 conduits)</p>		
<p>Sira 05ATEX1129X – Flameproof</p>		
<p>Equipment Group II, Category 1/2 GD</p>	<p>Ex db IIC T6...T2 Ga/Gb</p>	<p>Ex tb IIIC T85°C...T265°C Db</p>
<p>Harmonized Standards: EN 60079-0:2012/A11:2013; EN 60079-1:2014; EN 60079-26:2015; EN 60079-31:2014</p>		
<p>RoHS Directive (2011/65/EU)</p>		
<p>The Model 2130 is in conformity with Directive 2011/65/EU of the European Parliament and of the Council on the restriction of the use of certain hazardous substances in electrical and electronic equipment.</p>		
<p>(Minor variations in design to suit the application and/or mounting requirements are identified by alpha/numeric characters where indicated * above)</p>		
<p>Page 3 of 4</p>		<p>en</p>

Figure 11. EU Declaration of Conformity for Rosemount 2130 (Page 4)

The image shows a page from an EU Declaration of Conformity document. At the top left is the Emerson logo, which consists of a stylized flag icon above the word "EMERSON". To the right of the logo is the text "EU Declaration of Conformity" in a large, bold font, with "No: RMD 1075 Rev. J" underneath it. On the far right is the CE mark. Below this header section, there is a horizontal line. Underneath the line, the text "ATEX Notified Body" is centered. Below that, the text "Sira Certification Service [Notified Body Number: 0518]" is centered, followed by "Unit 6, Hawarden Industrial Park," and "Hawarden, CH5 3US, United Kingdom" on separate lines. A second horizontal line is below this text. The center of the page is dominated by a large, faint, light-green watermark of the CE mark. At the bottom of the page, there is a footer area with "Page 4 of 4" on the left and "en" on the right.

含有China RoHS管控物质超过最大浓度限值的部件型号列表 Rosemount 2130
List of Rosemount 2130 Parts with China RoHS Concentration above MCVs

部件名称 Part Name	有害物质 / Hazardous Substances					
	铅 Lead (Pb)	汞 Mercury (Hg)	镉 Cadmium (Cd)	六价铬 Hexavalent Chromium (Cr +6)	多溴联苯 Polybrominated biphenyls (PBB)	多溴联苯醚 Polybrominated diphenyl ethers (PBDE)
电子组件 Electronics Assembly	X	O	O	O	O	O
壳体组件 Housing Assembly	O	O	O	X	O	O
传感器组件 Sensor Assembly	X	O	O	O	O	O

本表格系依据SJ/T11364的规定而制作。

This table is proposed in accordance with the provision of SJ/T11364.

O: 意为该部件的所有均质材料中该有害物质的含量均低于GB/T 26572所规定的限量要求。

O: Indicate that said hazardous substance in all of the homogeneous materials for this part is below the limit requirement of GB/T 26572.

X: 意为在该部件所使用的所有均质材料里，至少有一类均质材料中该有害物质的含量高于GB/T 26572所规定的限量要求。

X: Indicate that said hazardous substance contained in at least one of the homogeneous materials used for this part is above the limit requirement of GB/T 26572.



Global Headquarters

Emerson Automation Solutions

6021 Innovation Blvd.
Shakopee, MN 55379, USA
+1 800 999 9307 or +1 952 906 8888
+1 952 949 7001
RFQ.RMD-RCC@Emerson.com

North America Regional Office

Emerson Automation Solutions

8200 Market Blvd.
Chanhassen, MN 55317, USA
+1 800 999 9307 or +1 952 906 8888
+1 952 949 7001
RMT-NA.RCCRFQ@Emerson.com

Latin America Regional Office

Emerson Automation Solutions

1300 Concord Terrace, Suite 400
Sunrise, FL 33323, USA
+1 954 846 5030
+1 954 846 5121
RFQ.RMD-RCC@Emerson.com

Europe Regional Office

Emerson Automation Solutions

Neuhofstrasse 19a P.O. Box 1046
CH 6340 Baar
Switzerland
+41 (0) 41 768 6111
+41 (0) 41 768 6300
RFQ.RMD-RCC@Emerson.com

Asia Pacific Regional Office

Emerson Automation Solutions

1 Pandan Crescent
Singapore 128461
+65 6777 8211
+65 6777 0947
Enquiries@AP.Emerson.com

Middle East and Africa Regional Office

Emerson Automation Solutions

Emerson FZE P.O. Box 17033
Jebel Ali Free Zone - South 2
Dubai, United Arab Emirates
+971 4 81 18100
+971 4 8865465
RFQ.RMTMEA@Emerson.com



[Linkedin.com/company/Emerson-Automation-Solutions](https://www.linkedin.com/company/Emerson-Automation-Solutions)



[Twitter.com/Rosemount_News](https://twitter.com/Rosemount_News)



[Facebook.com/Rosemount](https://www.facebook.com/Rosemount)



[Youtube.com/user/RosemountMeasurement](https://www.youtube.com/user/RosemountMeasurement)

Emerson Terms and Conditions of Sale are available upon request.
The Emerson logo is a trademark and service mark of Emerson Electric Co.
Rosemount is a mark of one of the Emerson family of companies.
All other marks are the property of their respective owners.
© 2019 Emerson. All rights reserved.