

Micro Motion™ HPC010P Ultra High Pressure Flowmeter



Safety and approval information

This Micro Motion product complies with all applicable European directives when properly installed in accordance with the instructions in this manual. Refer to the EU declaration of conformity for directives that apply to this product. The EU declaration of conformity, with all applicable European directives, and the complete ATEX Installation Drawings and Instructions are available on the internet at www.emerson.com or through your local Micro Motion support center.

Information affixed to equipment that complies with the Pressure Equipment Directive, can be found on the internet at www.emerson.com.

For hazardous installations in Europe, refer to standard EN 60079-14 if national standards do not apply.

Other information

Full product specifications can be found in the product data sheet. Troubleshooting information can be found in the configuration manual. Product data sheets and manuals are available from the Micro Motion web site at www.emerson.com.

Return policy

Follow Micro Motion procedures when returning equipment. These procedures ensure legal compliance with government transportation agencies and help provide a safe working environment for Micro Motion employees. Micro Motion will not accept your returned equipment if you fail to follow Micro Motion procedures.

Return procedures and forms are available on our web support site at www.emerson.com, or by phoning the Micro Motion Customer Service department.

Emerson Flow customer service

Email:

- Worldwide: flow.support@emerson.com
- Asia-Pacific: APflow.support@emerson.com

Telephone:

North and South America		Europe and Middle East		Asia Pacific	
United States	800-522-6277	U.K.	0870 240 1978	Australia	800 158 727
Canada	+1 303-527-5200	The Netherlands	+31 (0) 704 136 666	New Zealand	099 128 804
Mexico	+41 (0) 41 7686 111	France	0800 917 901	India	800 440 1468
Argentina	+54 11 4837 7000	Germany	0800 182 5347	Pakistan	888 550 2682
Brazil	+55 15 3413 8000	Italy	8008 77334	China	+86 21 2892 9000
		Central & Eastern	+41 (0) 41 7686 111	Japan	+81 3 5769 6803
		Russia/CIS	+7 495 995 9559	South Korea	+82 2 3438 4600
		Egypt	0800 000 0015	Singapore	+65 6 777 8211
		Oman	800 70101	Thailand	001 800 441 6426
		Qatar	431 0044	Malaysia	800 814 008
		Kuwait	663 299 01		
		South Africa	800 991 390		
		Saudi Arabia	800 844 9564		
		UAE	800 0444 0684		

Contents

Chapter 1	Planning.....	5
	1.1 Installation checklist.....	5
	1.2 Best practices.....	5
	1.3 Vibration limits.....	6
	1.4 Temperature limits.....	6
Chapter 2	Mounting.....	7
	2.1 Mount the sensor.....	7
	2.2 Mount the enhanced core processor	7
	2.3 Mount the I.S. barrier	9
	2.4 Attach extended electronics.....	9
Chapter 3	Transmitter power and I/O wiring.....	11
	3.1 Options for wiring.....	11
	3.2 Connect 4-wire cable.....	11
	3.3 Connect 9-wire cable.....	15
Chapter 4	Grounding.....	19
Chapter 5	Purge the sensor case	21
Chapter 6	Pressure relief.....	23

1 Planning

1.1 Installation checklist

- Make sure that the hazardous area specified on the approval tag is suitable for the environment in which the meter will be installed.
- Verify that the local ambient and process temperatures are within the limits of the meter.
- If the sensor has an integral transmitter, no wiring is required between the sensor and transmitter. Follow the wiring instructions in the transmitter installation manual for signal and power wiring.
- If the transmitter has remote-mounted electronics, follow the instructions in this manual for wiring between the sensor and the transmitter, and then follow the instructions in the transmitter installation manual for power and signal wiring.
- For optimal performance, install the sensor in the preferred orientation. The sensor will work in any orientation as long as the flow tubes remain full of process fluid.

Table 1-1: Preferred sensor orientation

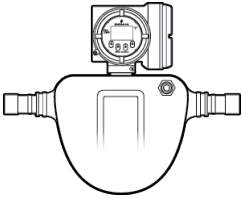
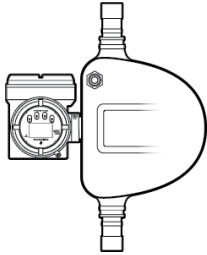
Liquids	
Slurries and self-draining applications	

- Orient the sensor so that personnel and equipment will not be exposed to escaping pressurized discharge from the rupture disk. The sensor has a rupture disk to evacuate the case in the unlikely event of a loss of primary containment.
- Install the meter so that the flow direction arrow on the sensor case matches the actual forward flow of the process. (Flow direction is also software-selectable.)

1.2 Best practices

The following information can help you get the most from your sensor.

- There are no pipe run requirements for Micro Motion sensors. Straight runs of pipe upstream or downstream are unnecessary.
- If the sensor is installed in a vertical pipeline, liquids and slurries should flow upward through the sensor.
- Keep the sensor full of process fluid.
- For halting flow through the sensor with a single valve, install the valve downstream from the sensor.
- Minimize bending and torsional piping loads on the meter. Do not use the meter to align misaligned piping.
- The sensor does not require external supports. The flanges will support the sensor in any orientation.

1.3 Vibration limits

- 5 to 1,000 Hz; 1.25E-4 g2/Hz per IEC 60068-2-64
- Total: 0.35g RMS

Vibration isolation should be used in installations above 0.35 g RMS or for applications requiring Lloyd's approval.

Vibration isolation clamps are available as a spare part. For more information about mounting a sensor in high vibration environments, contact Micro Motion.

1.4 Temperature limits

Component	Limit
Process fluid temperature	-50.8 °F (-46 °C) to 392 °F (200 °C)
Ambient temperature	-40 °F (-40.0 °C) to 140 °F (60.0 °C)

Notes

- In all cases, the electronics cannot be operated where the ambient temperature is below -40 °F (-40.0 °C) or above 140 °F (60.0 °C). If a sensor is to be used where the ambient temperature is outside of the range permissible for the electronics, the electronics must be remotely located where the ambient temperature is within the permissible range, as indicated by the shaded area of the temperature limit graphs.
- Temperature limits may be further restricted by hazardous area approvals. Refer to the hazardous area approvals documentation shipped with the sensor or available from www.emerson.com/flowmeasurement.

2 Mounting

2.1 Mount the sensor

Use your common practices to minimize torque and bending load on process connections.

Tip

To reduce the risk of condensation problems, do not orient transmitters or sensor junction boxes with their conduit openings pointing upward.



NOTICE

Lifting the sensor by the electronics or rupture disk can damage the device.

Figure 2-1: Mounting the sensor

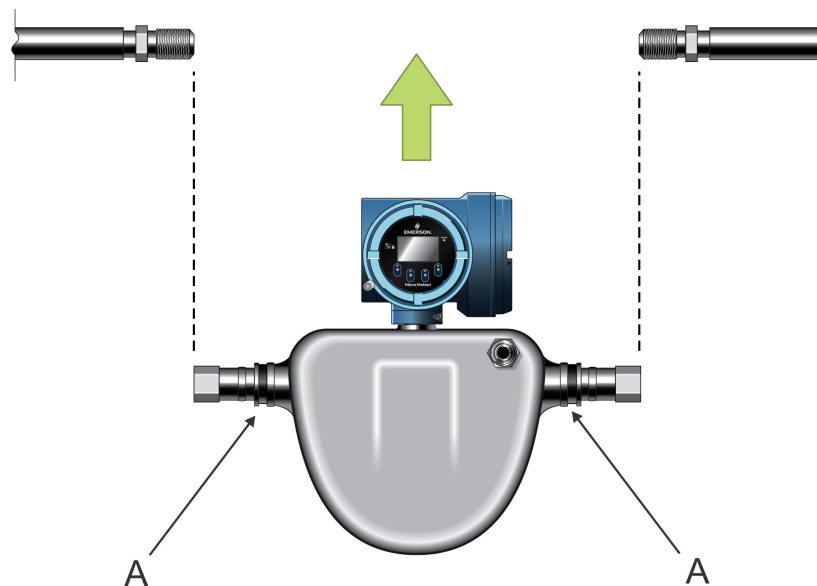

A. *Optional: Use the sensor grooves for mounting the sensor.*

Notes

- Do not use the sensor to support the piping.
- The sensor does not require external supports. The flanges will support the sensor in any orientation.

2.2 Mount the enhanced core processor

Procedure

1. If desired, reorient the core processor housing on the bracket.

- a) Loosen each of the four cap screws.
 - b) Rotate the bracket so that the core processor is oriented as desired.
 - c) Tighten the cap screws, torquing to 2.2 ft lbf (3 N m) to 3 ft lbf (4 N m).
2. Attach the mounting bracket to an instrument pole or wall. For pipe mount, two user-supplied U-bolts are required.

Figure 2-2: Pipe mount

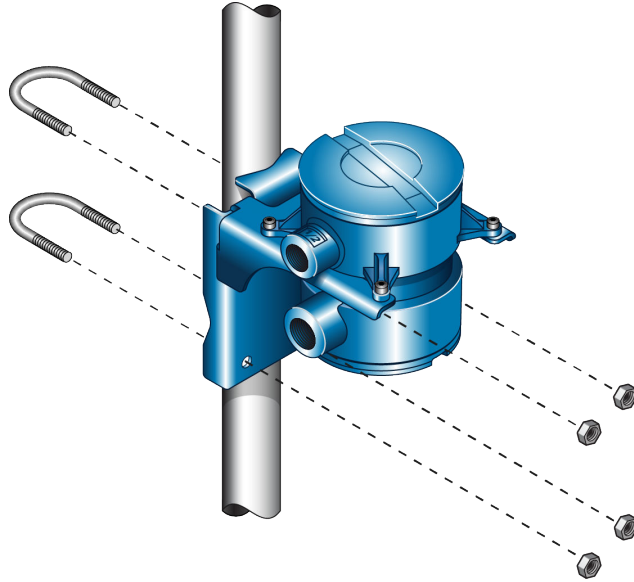
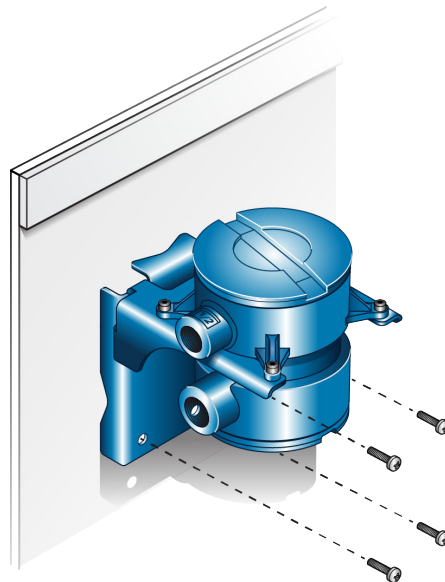

Figure 2-3: Wall mount



2.3 Mount the I.S. barrier

Use this procedure if you are mounting an MVD™ Direct Connect™ I.S. barrier.

Procedure

1. Snap the barrier onto a 1.38 in (35 mm) DIN rail. You can mount it in either direction.
To remove the barrier from the rail, lift the bottom lock.
2. Hook one end of the end clamp over the DIN rail.
3. Position the end clamp snugly against the barrier.
4. Tighten the screw until the end clamp is securely fastened to the DIN rail.
5. Close the cover and fasten the clamps.

Figure 2-4: Barrier mount on DIN rail

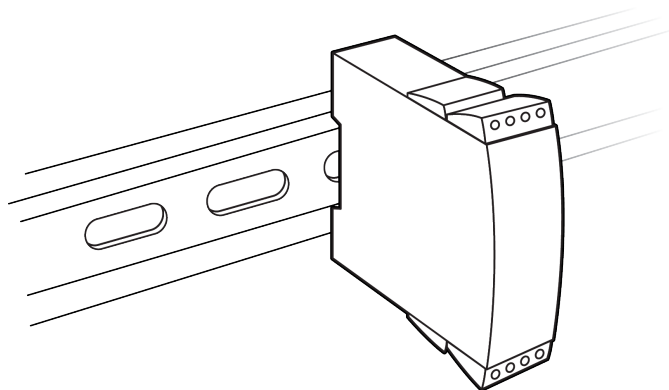

2.4 Attach extended electronics

If your installation has a sensor with extended electronics, you will need to install the extender onto the sensor case.

Note

Extended core processors are matched at the factory to specific sensors. Keep each core processor together with the sensor with which it was shipped.

! NOTICE

Keep the extender and feedthrough clean and dry. Moisture or debris in the extender or feedthrough can damage electronics and result in measurement error or flowmeter failure.

Procedure

1. Remove and recycle the plastic cap from the feedthrough on the sensor.

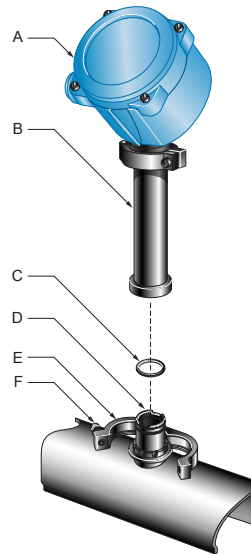

- A. Transmitter or core processor
- B. Extender
- C. O-ring
- D. Feedthrough
- E. Clamping ring
- F. Clamping screw

2. Loosen the clamping screw and remove the clamping ring. Leave the O-ring in place on the feedthrough.
3. Remove and recycle the plastic plug from the extender.
4. Fit the extender onto the feedthrough by carefully aligning the notches on the bottom of the extender with the notches on the feedthrough.
5. Close the clamping ring and tighten the clamping screw to 13 in lbf (1.47 N m) to 18 in lbf (2.03 N m).

3 Transmitter power and I/O wiring

3.1 Options for wiring

The wiring procedure you follow depends on which electronics option you have.

Table 3-1: Wiring procedures by electronics option

Electronics option	Wiring procedure
Integral transmitter	The transmitter is already connected to the sensor. No wiring is required between sensor and transmitter. See the transmitter installation manual for wiring the power and signal cable to the transmitter.
Extended electronics	The electronics are separated from the sensor by an extender and must be attached as described in Attach extended electronics . There is no wiring required because the physical connection includes the electrical connection.
MVD Direct Connect	There is no transmitter to wire. See the <i>Micro Motion MVD Direct Connect Meters</i> manual for wiring the power and signal cable between the sensor and the direct host. Refer to Connect power to the I.S. barrier .
Integral core processor with remote transmitter	The core processor is already connected to the sensor. Connect a 4-wire cable between the core processor and transmitter. Refer to Connect the wires to the core processor terminals .

 **WARNING**

Make sure the hazardous area specified on the sensor approval tag is suitable for the environment in which the sensor will be installed. Failure to comply with the requirements for intrinsic safety in a hazardous area could result in an explosion.

 **NOTICE**

Fully close and tighten all housing covers and conduit openings. Improperly sealed housings can expose electronics to moisture, which can cause measurement error or flowmeter failure. Inspect and grease all gaskets and O-rings.

3.2 Connect 4-wire cable

3.2.1 4-wire cable types and usage

Micro Motion offers two types of 4-wire cable: shielded and armored. Both types contain shield drain wires.

The cable supplied by Micro Motion consists of one pair of red and black 18 AWG (0.823 mm²) wires for the VDC connection, and one pair of white and green 22 AWG (0.326 mm²) wires for the RS-485 connection.

User-supplied cable must meet the following requirements:

- Twisted pair construction.
- Applicable hazardous area requirements, if the core processor is installed in a hazardous area.
- Wire gauge appropriate for the cable length between the core processor and the transmitter, or the host.

Table 3-2: Wire gauge

Wire gauge	Maximum cable length
VDC 22 AWG (0.326 mm ²)	300 ft (91 m)
VDC 20 AWG (0.518 mm ²)	500 ft (152 m)
VDC 18 AWG (0.823 mm ²)	1,000 ft (305 m)
RS-485 22 AWG (0.326 mm ²) or larger	1,000 ft (305 m)

3.2.2 Maximum cable lengths

Table 3-3: Maximum lengths for Micro Motion cable

Cable type	To transmitter	Maximum length
Micro Motion 9-wire	All other MVD transmitters	60 ft (20 m)
Micro Motion 4-wire	All 4-wire MVD transmitters	<ul style="list-style-type: none"> • 1000 ft (300 m) without Ex-approval • 500 ft (150 m) with IIC rated sensors • 1000 ft (300 m) with IIB rated sensors

Table 3-4: Maximum lengths for user-supplied 4-wire cable

Wire function	Wire size	Maximum length
Power (VDC)	22 AWG (0,35 mm ²)	300 ft (90 m)
	20 AWG (0,5 mm ²)	500 ft (150 m)
	18 AWG (0,8 mm ²)	1000 ft (300 m)
Signal (RS-485)	22 AWG (0,35 mm ²) or larger	1000 ft (300 m)

3.2.3 Prepare a cable with a metal conduit

Procedure

1. Remove the core processor cover using a flat-blade screw driver.
2. Run the conduit to the sensor.
3. Pull the cable through the conduit.
4. Cut the drain wires and let them float at both ends of the conduit.

3.2.4 Prepare a cable with user-supplied cable glands

Procedure

1. Remove the core processor cover using a flat-blade screw driver.
2. Pass the wires through the gland.
3. Terminate the shield and drain wires inside the gland.
4. Assemble the gland according to vendor instructions.

3.2.5 Prepare a cable with Micro Motion-supplied cable glands

Procedure

1. Remove the core processor cover using a flat-blade screw driver.
2. Pass the wires through the gland nut and clamping insert.

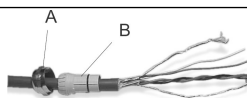

- A. Gland nut
B. Clamping insert

3. Strip the cable jacket.

Option	Description
NPT gland type	Strip 4.5 in (114 mm)
M20 gland type	Strip 4.25 in (108 mm)

4. Remove the clear wrap and filler material.
5. Strip most of the shielding.

Option	Description
NPT gland type	Strip all but 0.75 in (19 mm)
M20 gland type	Strip all but 0.5 in (13 mm)

6. Wrap the drain wires twice around the shield and cut off the excess drain wires.



- A. Drain wires wrapped around shield

7. For foil (shielded cable) only:

Note

For braided (armored cable) skip this step and continue to the next step.

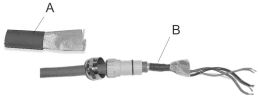
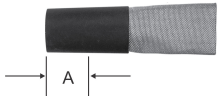
Option	Description
NPT gland type	<p>a. Slide the shielded heat shrink over the drain wires. Ensure that the wires are completely covered.</p> <p>b. Apply 250 °F (121.1 °C) heat to shrink the tubing. Do not burn the cable.</p> <p>c. Position the clamping insert so the interior end is flush with the braid of the heat shrink.</p> <div style="text-align: center;">  </div> <p>A. Shielded heat shrink B. After heat is applied</p>
M20 gland type	<p>Trim 0.3 in (8 mm).</p> <div style="text-align: center;">  </div> <p>A. Trim</p>

- Assemble the gland by folding the shield or braid back over the clamping insert and 0.125 in (3 mm) past the O-ring.

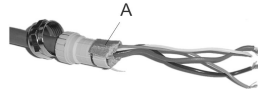

A. Shield folded back

- Install the gland body into the conduit opening on the core processor housing.
- Insert the wires through the gland body and tighten the gland nut onto the gland body.



A. Shield folded back
B. Gland body

3.2.6 Connect the wires to the core processor terminals

After the 4-wire cable has been prepared and shielded (if required), connect the individual wires of the 4-wire cable to the terminals on the core processor.

Procedure

1. Connect the wires to the core processor terminals.

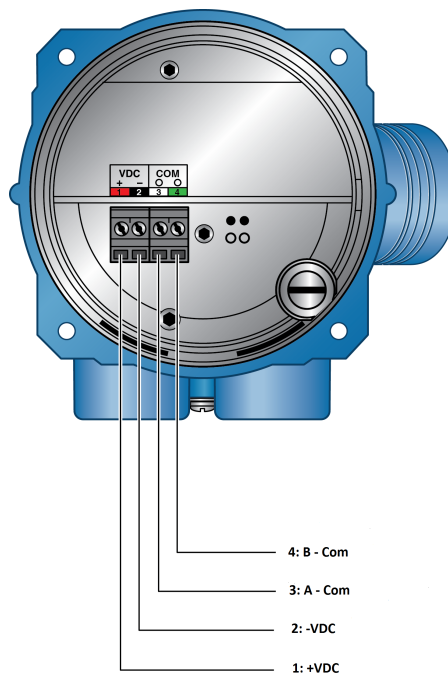

2. Reinstall the core processor cover.
3. Torque the cover screws to:
 - For aluminum housing: 10 in lbf (1.13 N m) to 13 in lbf (1.47 N m)
 - For stainless steel housing: minimum 19 in lbf (2.15 N m)If properly seated, there will be no gap between cover and base.
4. Connect the wires to the transmitter terminals using the transmitter installation manual.

3.3 Connect 9-wire cable

3.3.1 Connect the 9-wire cable

Procedure

1. Prepare and install the cable according to the instructions in the *Micro Motion 9-Wire Flowmeter Cable Preparation and Installation Guide*.
2. Insert the stripped ends of the individual wires into the terminal blocks of the junction box. Ensure that no bare wires remain exposed.

3. Match the wires color for color. For wiring at the transmitter or remote core processor, refer to the transmitter documentation.
4. Tighten the screws to hold the wires in place.
5. Ensure integrity of gaskets, then tightly close and seal the junction box cover and all housing covers.
6. Refer to the transmitter installation manual for signal and power wiring instructions.

3.3.2 Connect the 9-wire cable on a remote ECP

Procedure

1. Insert the stripped ends of the individual wires into the terminal blocks. Ensure that no bare wires remain exposed.
2. Match the wires color for color.
3. Tighten the screws to hold the wires in place.
4. Ensure integrity of gaskets, then tightly close and seal all housing covers.

3.3.3 Wire the MVD Direct Connect I.S. barrier

Procedure

Connect the core processor to the barrier:

- a) Connect the RS-485 wires from the core processor to the I.S. RS-485 terminals at the barrier (terminals 43 and 44), matching A and B. See the following table and figure.
- b) Connect the power supply wires from the core processor to the I.S. VDC terminals at the barrier (terminals 42 and 41), matching positive and negative (+ and -). Do not terminate the shields at the barrier. See the following table and figure.

Function	Core processor terminals	Barrier I.S. terminals
RS-485 A	3	43
RS-485 B	4	44
VDC +	1	42
VDC -	2	41

- c) Connect the RS-485 wires to the non-I.S. RS-485 terminals at the barrier (terminals 13 and 14). These wires will be used in the next step to connect the barrier to the remote host. Do not terminate the shields at the barrier.
- d) Connect the power supply wires to the non-I.S. VDC terminals at the barrier (terminals 11 and 12). These wires will be used in the next step to connect the barrier to the power supply.

Figure 3-1: Barrier terminals

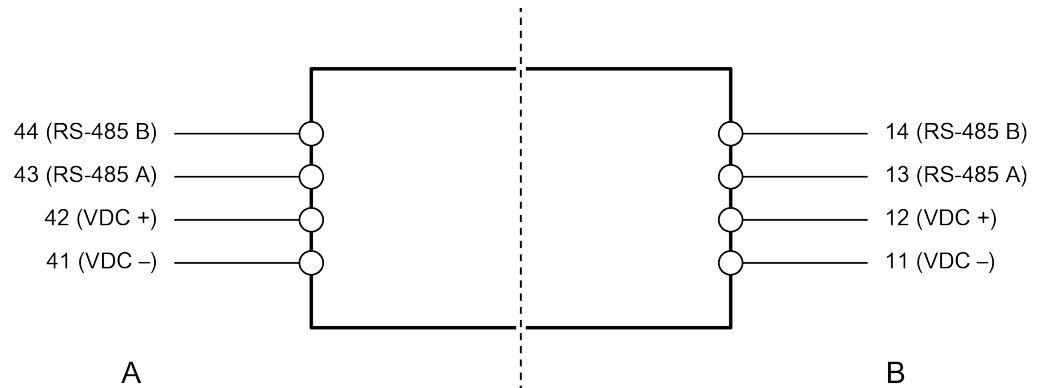

A. I. S. terminals for connection to the core processor

B. Non I.S. terminals for connection to remote host and power supply

3.3.4 Connect power to the I.S. barrier

- You can connect multiple MVD Direct Connect installations to a single power supply, as long as each installation receives sufficient power.
- For power supply to I.S. barrier connections, the power supply can be used to power other equipment.

Procedure

Connect the power supply wires between the enhanced core processor and the barrier, matching positive and negative (+ and -).

Figure 3-2: Barrier terminals

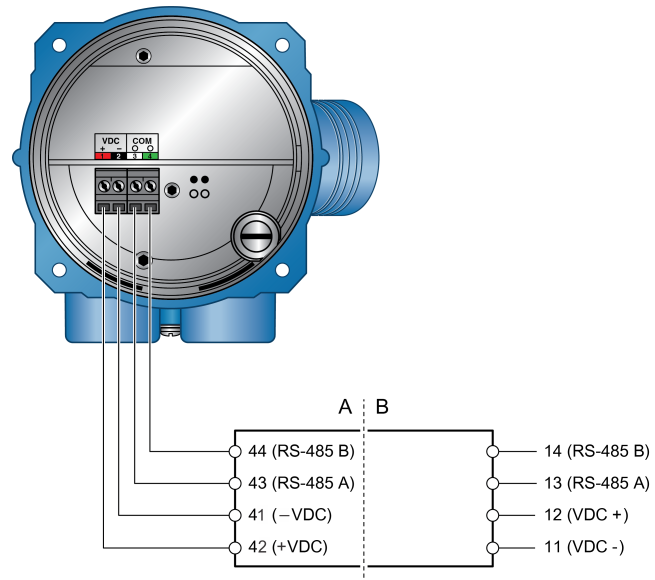

- A. I.S. terminals for connection to enhanced core processor
- B. Non I.S. terminals for connection to remote host and power supply

4 Grounding

The meter must be grounded according to the standards that are applicable at the site. The customer is responsible for knowing and complying with all applicable standards.

Prerequisites

Use the following guides for grounding practices:

- In Europe, IEC 60079-14 is applicable to most installations, in particular Sections 16.2.2.3 and 16.2.2.4.
- In the U.S.A. and Canada, ISA 12.06.01 Part 1 provides examples with associated applications and requirements.

If no external standards are applicable, follow these guidelines to ground the sensor:

- Use copper wire, 14 AWG (2.08 mm²) or larger wire size.
- Keep all ground leads as short as possible, less than 1 Ω impedance.
- Connect ground leads directly to earth, or follow plant standards.

NOTICE

Ground the flowmeter to earth, or follow ground network requirements for the facility. Improper grounding can cause measurement error.

Procedure

- Check the joints in the pipeline.
 - If the joints in the pipeline are ground-bonded, the sensor is automatically grounded and no further action is necessary (unless required by local code).
 - If the joints in the pipeline are not grounded, connect a ground wire to the grounding screw located on the sensor electronics.

Tip

The sensor electronics may be a transmitter, core processor, or junction box. The grounding screw may be internal or external.

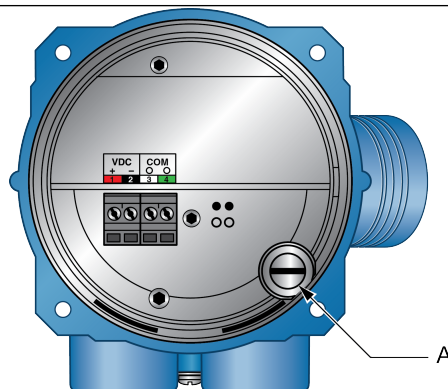

A. Grounding screw

5 Purge the sensor case

Prerequisites

Make sure the following are available before beginning the purge procedure:

- Teflon™ tape
- Argon or nitrogen gas sufficient to purge the sensor case

Whenever a purge plug is removed from the sensor case, you must purge the case again.

Procedure

1. Shut down the process, or set control devices for manual operation. Before performing the case purging procedure, shut down the process or set the control devices for manual operation. Performing the purge procedure while the flowmeter is operating could affect measurement accuracy, resulting in inaccurate flow signals.
2. Remove both purge plugs from the sensor case. If purge lines are being used, open the valve in the purge lines.

WARNING

- Stay clear of the rupture disk pressure relief area. High-pressure fluid escaping from the sensor can cause severe injury or death. The sensor must be oriented so that personnel and equipment will not be exposed to any discharge along the pressure relief path.
- Take all necessary precautions when removing purge plugs. Removing a purge plug compromises the secondary containment of the sensor and could expose the user to process fluid.
- Improper pressurization of the sensor case could result in personal injury.

NOTICE

Be sure to use thread protectors when removing the purge fitting so as not to damage the disk membrane surrounding the rupture disk.

3. Prepare the purge plugs for reinstallation by wrapping them with 2–3 turns of Teflon tape.
4. Connect the supply of nitrogen or argon gas to the inlet purge connection or open inlet purge line. Leave the outlet connection open.
 - Exercise caution to avoid introducing dirt, moisture, rust, or other contaminants into the sensor case.
 - If the purge gas is heavier than air (such as argon), locate the inlet lower than the outlet, so that the purge gas will displace air from bottom to top.
 - If the purge gas is lighter than air (such as nitrogen), locate the inlet higher than the outlet, so that the purge gas will displace air from top to bottom.

5. Make sure that there is a tight seal between the inlet connection and sensor case, so that air cannot be drawn by suction into the case or purge line during the purging process.
6. Run purge gas through the sensor.

The purge time is the amount of time required for full exchange of atmosphere to inert gas. The larger the line size, the greater amount of time is required to purge the case. If purge lines are being used, increase the purge time to fill the additional volume of the purge line.

Note

Keep the purge gas pressure below 7.25 psi (0.5 bar).

7. At the appropriate time, shut off the gas supply, then immediately seal the purge outlet and inlet connections with the purge plugs.
Avoid pressurizing the sensor case. If pressure inside the case elevates above atmospheric pressure during operation, the flowmeter density calibration will be inaccurate.
8. Make sure that the purge fitting seals are tight so that air cannot be drawn by suction into the sensor case.

6 Pressure relief

HPC sensors are available with a rupture disk installed on the case. Rupture disks vent process fluid from the sensor case in the unlikely event of a flow tube breach. Some users connect a pipeline to the rupture disk to help contain escaping process fluid. For more information about rupture disks, contact customer service.

If the sensor has a rupture disk, keep it installed at all times as it would otherwise be necessary to re-purge the case. If the rupture disk is activated by a tube breach, the seal in the rupture disk will be broken, and the Coriolis meter should be removed from service.

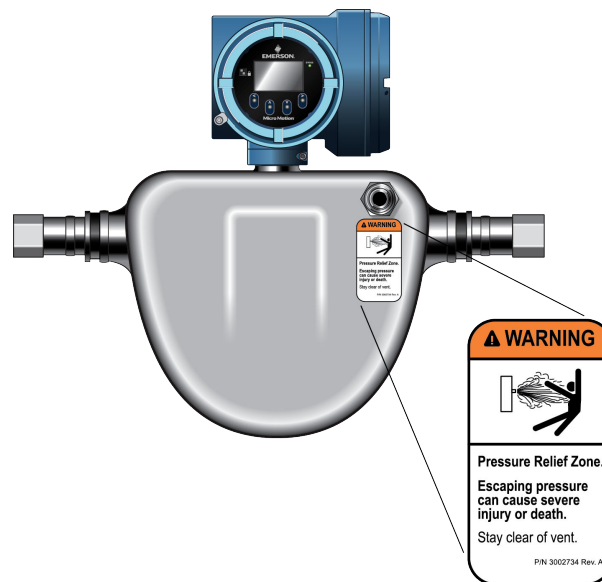

! WARNING

Stay clear of the rupture disk pressure relief area. High-pressure fluid escaping from the sensor can cause severe injury or death.

The sensor must be oriented so that personnel and equipment will not be exposed to any discharge along the pressure relief path.

Important

If a rupture disk is used, the housing can no longer assume a secondary containment function.

! WARNING

Removing the purge fitting, blind plug, or rupture disks compromises the Ex-i Safety Certification, the Ex-tc Safety Certification, and the IP-rating of the Coriolis meter. Any modification to the purge fitting, blind plug, or rupture disks must maintain a minimum of IP66/IP67 Ratings.



MMI-20032352
Rev. AC
2019

Micro Motion Inc. USA

Worldwide Headquarters
7070 Winchester Circle
Boulder, Colorado USA 80301
T +1 303-527-5200
T +1 800-522-6277
F +1 303-530-8459
www.emerson.com

Micro Motion Europe

Emerson Automation Solutions
Neonstraat 1
6718 WX Ede
The Netherlands
T +31 (0) 318 495 555
T +31 (0) 70 413 6666
F +31 (0) 318 495 556
www.emerson.com/nl-nl

Micro Motion Asia

Emerson Automation Solutions
1 Pandan Crescent
Singapore 128461
Republic of Singapore
T +65 6363-7766
F +65 6770-8003

Micro Motion United Kingdom

Emerson Automation Solutions
Emerson Process Management Limited
Horsfield Way
Bredbury Industrial Estate
Stockport SK6 2SU U.K.
T +44 0870 240 1978
F +44 0800 966 181

©2019 Micro Motion, Inc. All rights reserved.

The Emerson logo is a trademark and service mark of Emerson Electric Co. Micro Motion, ELITE, ProLink, MVD and MVD Direct Connect marks are marks of one of the Emerson Automation Solutions family of companies. All other marks are property of their respective owners.

MICRO MOTION™

