

General-Purpose, Dome-Loaded Pressure-Reducing Regulators—RD(H)6 and RD(H)8 Series

Features

- Balanced poppet design
- Diaphragm sensing
- Dome-to-outlet pressure ratio approximately 1:1
- Outlet gauge connection: 1/4 in. female NPT

Options

- Pilot regulator (not shown)
- Gauge connections—choice of 4 configurations
- NACE MR0175/ISO 15156-compliant models
- Special cleaning to ASTM G93 Level C



Technical Data

Series	Maximum Inlet Pressure psig (bar)	Maximum Outlet Control Pressure psig (bar)	Sensing Type	Temperature Range °F (C°)	Flow Coefficient (C _v)	Seat Diameter in. (mm)	Inlet and Outlet Connections	Gauge / Dome Connection	Weight (Without Flanges) lb (kg)
RD6 RDH6	RD: 1015 (70.0)	RD: 1015 (70.0)	Diaphragm	-4 to 176 (-20 to 80) See Pressure-Temperature Ratings , page 32.	1.95	0.39 (10.0)	3/4 in. NPT, ISO/BSP parallel thread, EN or ASME flange	Gauge: 1/4 in. NPT;	8.8 (4.0)
RD8 RDH8	RDH: 5800 (400)	RDH: 5800 (400) (2537 [175] with pilot regulator)			2.07		1 in. NPT, ISO/BSP parallel thread, EN or ASME flange	Dome: 1/4 in. ISO/BSP parallel thread	

See page 39 for RD(H)6 flow data.

Materials of Construction

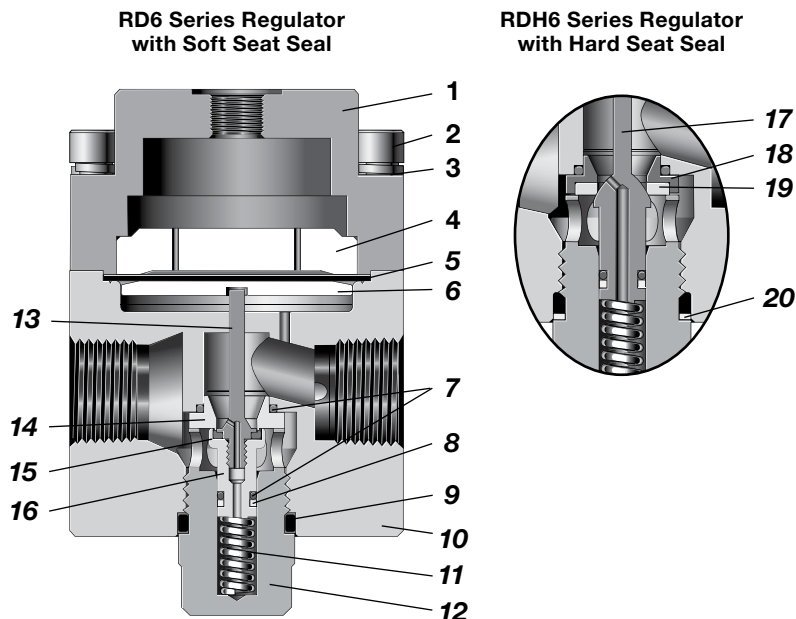

Component	Material / Specification
1 Dome	316L SS / A479 or EN10088
2 Cap screw	A4-80
3 Washer	A4
4 Dome plate	316L SS / A479 or EN10088
5 Diaphragm	<i>EPDM, FKM, or nitrile</i>
6 Diaphragm plate	316L SS / A479 or EN10088
7 O-ring	<i>EPDM, FKM, or nitrile</i>
8 Backup ring	PTFE
9 Plug O-ring	<i>EPDM, FKM, or nitrile</i>
10 Body	316L SS / A479 or EN10088
11 Poppet spring	302 SS / A240
12 Body plug	316L SS / A479 or EN10088
RD Series Only Components	
13 Poppet	316L SS / A479 or EN10088
14 Seat	
15 Seat seal	<i>EPDM, FKM, or nitrile</i>
16 Poppet housing	316L SS / A479 or EN10088
RDH Series Only Components	
17 Poppet	413 SS / A276
18 Seat	316L SS / A479 or EN10088
19 Seat seal	<i>PCTFE or PEEK</i>
20 Backup ring	PTFE

Wetted lubricants: *Silicone-based and synthetic hydrocarbon-based*

Gauge plugs (not shown): 431 SS / A276.

Flow Data

The graphs illustrate the change or “droop” in outlet pressures as the flow rate increases. For more flow curve information, contact your authorized Swagelok representative.

RDH6 Series

Flow Coefficient: 1.95

Maximum Inlet Pressure: RDH6—5800 psig (400 bar)

Outlet Pressure Control Range: 0 to 1450 psig (0 to 100 bar)

Pressure Control Range

- 0 to 362 psig (0 to 25.0 bar)
- 0 to 1450 psig (0 to 100 bar)

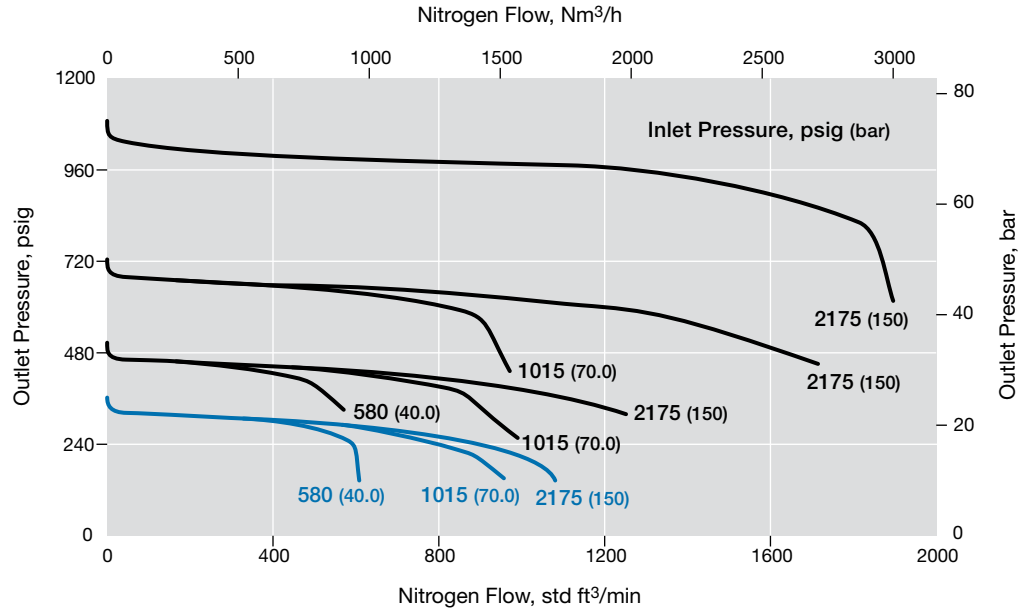

RDH6 Series

Flow Coefficient: 1.95

Maximum Inlet Pressure: RDH6—5800 psig (400 bar)

Outlet Pressure Control Range: 0 to 290 psig (0 to 20.0 bar)

Pressure Control Range

- 0 to 145 psig (0 to 10.0 bar)
- 0 to 362 psig (0 to 25.0 bar)

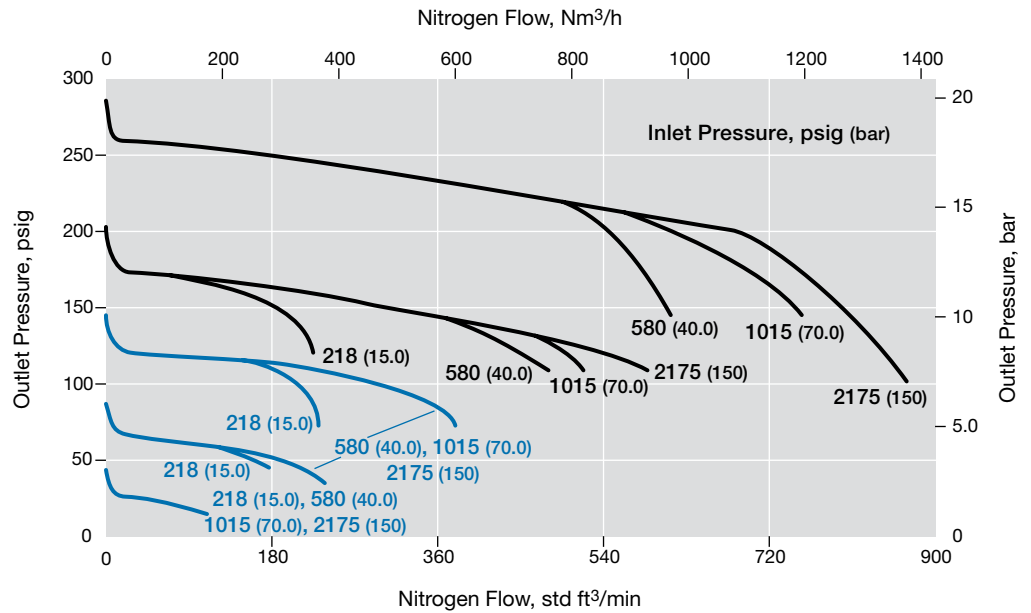

RD(H)8 Series

For flow curve information, contact your authorized Swagelok representative.

Dimensions

Dimensions, in inches (millimeters), are for reference only and are subject to change.

Series	End Connection Size	Dimensions, in. (mm)			
		A	B	C	D
RD(H)6	3/4 in.	5.12 (130)	3.22 (82.0)	3.50 (89.0)	2.16 (55.0)
RD(H)8	1 in.		3.07 (78.0)		

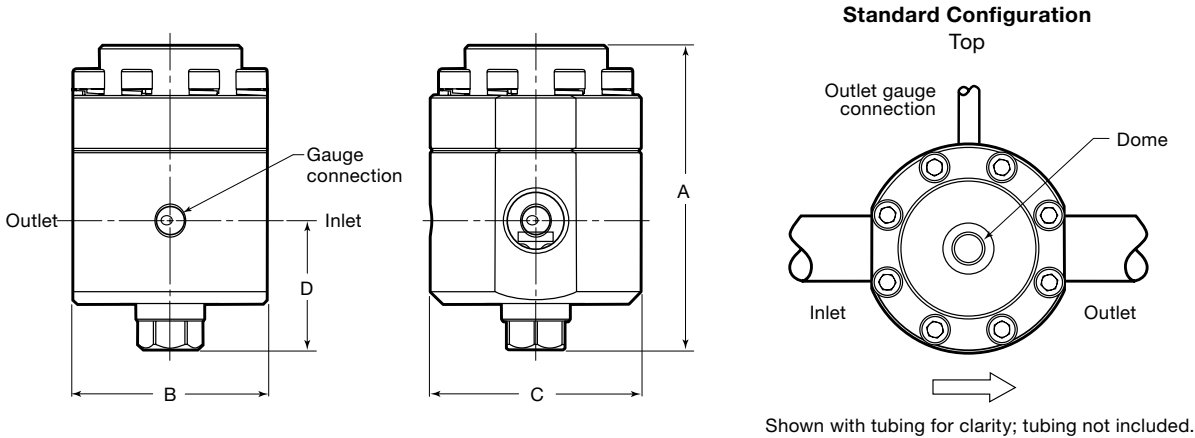

Ordering Information

Build an RD(H)6 and RD(H)8 series regulator ordering number by combining the designators in the sequence shown below.

1 2 3 4 5 6 7 8 9 10 11
RD FA 6 A 1 - 02 - X - V V V - GN2

1 Series

RD = 1015 psig (70.0 bar) maximum inlet pressure
RDH = 5800 psig (400 bar) maximum inlet pressure

2 Inlet / Outlet

B = Female ISO/BSP parallel thread
N = Female NPT
FA = ASME B16.5 flange
FD = EN 1092 (DIN) flange

3 Size

6 = 3/4 in. / DN20
8 = 1 in. / DN25

4 Pressure Class

Omit designator if flanges are not ordered.
A = ASME class 150
B = ASME class 300
C = ASME class 600
E = ASME class 1500
F = ASME class 2500
M = DN class PN16
N = DN class PN40

5 Flange Facing

Omit designator if flanges are not ordered.
1 = Raised face smooth
3 = RTJ

6 Body Material

02 = 316L SS

7 Pressure Control Range

X = No pilot regulator, standard
RD series with RS2 series pilot regulator
3 = 0 to 1015 psig (0 to 70.0 bar)
RDH series with RS2 series pilot regulator
4 = 0 to 145 psig (0 to 10.0 bar)
5 = 0 to 362 psig (0 to 25.0 bar)
6 = 0 to 1450 psig (0 to 100 bar)
7 = 0 to 2537 psig (0 to 175 bar)

For higher pressure control ranges with a pilot regulator, contact your authorized Swagelok representative for information.

8 Seal Material

V = Fluorocarbon FKM
N = Nitrile
E = EPDM

9 Diaphragm / Piston O-Rings

V = Fluorocarbon FKM
N = Nitrile
E = EPDM

10 Seat Seal Material

RD series
V = Fluorocarbon FKM
N = Nitrile
E = EPDM
RDH series
K = PCTFE
P = PEEK

11 Options

A = Antitamper
GN2 = Gauge connection, see below
GN4 = Gauge connection, see below
GN5 = Gauge connection, see below
None = Standard connection, see below

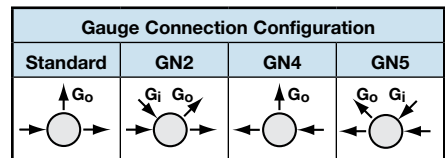

N = NACE MR0175/ISO 15156
G93 = ASTM G93 Level C-cleaned