



# INSTALLATION, OPERATION & MAINTENANCE INSTRUCTIONS

1455 Kleppe Lane ♦ Sparks, NV 89431-6467 ♦ (775) 359-4712 ♦ Fax (775) 359-7424  
E-mail: [haws@hawsco.com](mailto:haws@hawsco.com) ♦ website: [www.hawsco.com](http://www.hawsco.com)

No. 0002077032 (11)

## Model 8317CTFPC1D1

**NOTE TO INSTALLER: Please leave this information with the Maintenance Department.**

### LIMITED WARRANTY

HAWS warrants that this specific product is guaranteed against defective material or poor workmanship for a period of **one year from date of shipment**. HAWS liability under this warranty shall be discharged by furnishing without charge F.O.B. HAWS Factory any goods, or part thereof, which shall appear to the Company upon inspection to be of defective material or not of first class workmanship, provided that claim is made in writing to Haws within a reasonable period after receipt of the product. Where claims for defects are made, the defective part or parts shall be delivered to the Company, prepaid, for inspection. HAWS will not be liable for the cost of repairs, alterations or replacements, or for any expense connected therewith made by the owner or his agents, except upon written authority from HAWS, Sparks, Nevada. HAWS will not be liable for any damages caused by defective materials or poor workmanship, except for replacements, as provided above. Buyer agrees that Haws has made no other warranties either expressed or implied in addition to those above stated, except that of title with respect to any of the products or equipment sold hereunder and that HAWS shall not be liable for general, special, or consequential damages claimed to arise under the contract of sale.

The emergency equipment manufactured by HAWS is warranted to function if installation and maintenance instructions provided are adhered to. The units also must be used for the purpose for which they were intended. This product is intended to supplement first-aid treatment. Due to widely varying conditions, Haws cannot guarantee that the use of this emergency equipment will prevent serious injury or the aggravation of existing or prior injuries.

**NO OTHER WARRANTIES EXPRESSED OR IMPLIED ARE AUTHORIZED, PROVIDED OR GIVEN BY HAWS.**

**SHOULD YOU EXPERIENCE DIFFICULTY WITH THE INSTALLATION OF THIS MODEL PLEASE CALL:**

**TECHNICAL SUPPORT: 1-800-766-5612**

**FOR CUSTOMER SERVICE: 1-888-640-4297**

**RECOMMENDED TOOLS:** Pipe joint sealant, screwdriver, pipe wrench, three (3) rust resistant anchors (3/8" diameter), silicone caulking, level.

**MOVING UNIT:** Side arms on unit for power connection and heat trace termination are specified as "**NO LIFT**" on installation drawing. These are not designed to support the weight of the unit and attempts to move the unit using them will cause damage that will void the unit's warranty.

**LOCATION OF UNIT:** The Model 8317CTFPC1D1 Emergency Shower Eye / Face Wash should be installed in close proximity to potential accident areas. It should be clearly identified, free from obstructions and easy to access. Suitable for use in Class 1, Division 1 Group B, C, D areas. Temperature rating T6 (85° C).

**ELECTRICAL SUPPLY FOR MODEL 8317CTFPC1D1:** Electrical power required for standard heat traced unit is **120 VAC**. Average power consumption at 50° F (10° C) ambient temperature is 125 watts. Maximum less lighting is 150 watts. Connection at input junction box is 3/4" NPT. **DURING POTENTIALLY FREEZING PERIODS; INSURE THAT UNIT IS CONNECTED TO A CONTINUOUS POWER SUPPLY.**

**WATER SUPPLY:** The minimum recommended line is 1-1/4" IPS with 30-90 psi (2-6 ATM) flowing pressure. An inlet filter is recommended where sediment or mineral content is a problem. Inlet connection is 1-1/4" IPS. **WATER SUPPLY MUST BE FREEZE PROTECTED.**

**MAINTENANCE:** In freezing conditions, wipe eye/face wash head and dust cover dry after each use to prevent unwanted ice build-up. SP158B Freeze Protection Valve is a field serviceable item. Refer to SP158B Manual for more information.

**WARNING: Fire and shock hazards; Must use a ground fault electrical protection device (30mA GFEPD) for Heat Trace. Electrical fault currents may be insufficient to trip a conventional circuit breaker.**

## INSTALLATION PROCEDURE

Refer to Installation Drawings for clarification. Use pipe joint sealant on all connections.

**STEP 1:** Prepare the emergency shower foundation locating three 3/8" anchors (not supplied), for shower floor flange. Note flange hole positions so shower head eye/face wash and supply inlet will be in proper direction. Raise shower into position and shim under floor flange if required to maintain upright vertical.

**STEP 2:** Connect water supply as follows: **This model is designed for either a top water supply or a bottom water supply.** This model is shipped with a complete 1-1/4" IPS union connected at the top supply inlet. At the bottom supply inlet there is only half of a 1-1/4" IPS union. The other half of the union is connected to a freeze protection bleed valve located inside the shipping carton. Remove outer half of the 1-1/4" union from the top water inlet. Assemble the half union onto 1-1/4" IPS male thread of either the top or bottom water supply.

Complete supply connection at the desired 1-1/4" union. Attach the other half union with the freeze valve attached to the other unused union and complete the connection. Refer to SP158B Freeze Protection Valve installation instructions on Sheets 2 and 3 of installation drawing.

Turn on water supply and check for leaks, then operation of eye/face wash and shower together. If flow of either is inadequate check troubleshooting chart. Heat trace (supplied), insulate and weather seal inlet union and above ground supply (by others). If flow switch is used, heat-trace and insulate 6" above flow switch tee.

## INSTALLATION PROCEDURE

**STEP 3:** Connect electrical power supply conduit to input junction box using suitable conduit fitting into 3/4" NPT inlet. Install optional area light and indicator light, if desired. **For MODEL 8317CTFP C1 D1 (120V):** connect **120 volt AC** line to 16 gauge shower wires as follows: Black = 120 VAC, Red = 2<sup>nd</sup> Hot, Green = Ground.  
(Turn on power supply to complete installation. See Electrical Schematic Drawing, Sheet 4 of Installation Drawing). Power to be routed using rigid conduit and a seal fitting or Class 1, Division 1 rated armored cable and an appropriate gland fitting.

## OPERATING INSTRUCTIONS

Power to the 8317CTFP C1 D1 may be left on year round. The non-adjustable thermostat will shut off heat cable when air temperature rises to 55° - 65° F (12° - 18° C). Heat cycle will repeat when air temperature drops to between 45° - 55° F (7° - 13°C). Periodic check of water temperature from shower or eye/face wash will confirm normal operating temperatures between 45° - 95°F (7° - 35°C).

This unit is heated by low power heat trace cable suitable for freeze protection but not suitable for providing a warm shower from a cold water supply. Moments after activating shower, water temperature will drop to supply temperature.

ANSI recommends a comfortable shower temperature range of 60°F (15°C) to 100°F (38°C). For the protection of the user, we strongly recommend that some system be installed to provide tempered (warm) water to this shower and eye/face wash. Heat trace cable used on this shower heats slowly and may take 90 minutes to complete a full heat cycle.

No drain connection at bleed valve(s) is normally required. Valve(s) will remain closed unless power outage, high ambient temperature (with optional scald protection valve, only) or malfunction occurs (see Troubleshooting).

**NOTE: IF GROUND WATER IS BELOW 38°F (3.3°C) SIMPLY TESTING SHOWER MIGHT CAUSE BLEED VALVE TO OPEN. ONCE OPENED, COLD GROUND WATER WILL KEEP BLEED VALVE OPEN. SEE TROUBLESHOOTING GUIDE FOR PROCEDURE TO CLOSE BLEED VALVE ONCE OPENED.**

Periodic tests for proper function of shower and eye/face wash should be performed and recorded on inspection tags attached to unit or in separate maintenance logbook (preferred).

## IMPORTANT SAFETY NOTICE

THE NATIONAL ELECTRICAL CODE REQUIRE GROUND-FAULT EQUIPMENT PROTECTION ON EACH HEATING CABLE BRANCH CIRCUIT. TO REDUCE THE RISK OF FIRE CAUSED BY DAMAGE OR IMPROPER INSTALLATION, CIRCUIT BREAKERS SUCH AS SQUARE D QO-EPD AND QOB-EPD OR EQUIVALENT, WITH A 30mA TRIP LEVEL, SHOULD BE USED. PLEASE SUBSTITUTE THESE BREAKERS WHEREVER REFERENCE IS MADE TO CONVENTIONAL BREAKERS IN THIS DOCUMENT. ALTERNATIVE DESIGNS PROVIDING COMPARABLE LEVELS OF GROUND-FAULT PROTECTION MAY ALSO BE ACCEPTABLE.

## TROUBLESHOOTING

PROBLEM	REPAIR CHECKLIST
1. Continuous flow from freeze bleed valve.	1. If bleed water temperature is above 45°F (7°C), service bleed valve. For specific instruction regarding removal, maintenance and re-installment of this model, contact Haws Technical Support at 1-800-640-5612. If below 45°F (7°C), verify electric power to unit, then check thermostat. See item 3 below. Once opened, cold supply water, (45°F (7°C)), will keep freeze bleed valve open. To shut bleed valve, it must be warmed above 45°F (7°C).
2. Continuous flow from scald bleed valve. (Optional valve).	2. If bleed water temperature is below 90°F (32°C), service bleed valve. For specific instruction regarding removal, maintenance and re-installment of this model, contact Haws Technical Support at 1-800-640-5612. Above 100°F (38°C) may be due to direct sunlight or excess ambient temperature.
3. Shower and eye/face wash water temperature below 40°F or above 100°F.	3. Shut off electric power. All electric connections are made inside external junction box. Thermostat is mounted below junction box. Check thermostat leads to terminal block for good connections. Check thermostat setting: open thermostat side cover and check that temperature dial is set at 80°F. Self-regulating heat trace cable will not overheat shower until air temperature rises above 85°F (30°C).
4. Removal of thermostat.	4. a. Disconnect the black, red, and green wires at the thermostat (see page 8 of 8 for schematic). b. Disconnect the black, red, and green wires at the junction box. c. Loosen set screw on kee-klamp and disassemble the union between the junction box and thermostat (see page 7 of 8 for clarification). d. Remove thermostat from the shower assembly (remember to de-pressurize the shower prior to removal of thermostat and drain excess water by activating eyewash). Hold coupling into which thermostat is threaded firmly during removal in order to keep it securely attached to shower assembly; otherwise a leak may occur under the jacket.
5. Insufficient flow at shower and eye/face wash.	5. Verify minimum 30 PSI (2 ATM), 28 gallon (106 liters per minute) available supply. Check for blockage in lines.
6. Insufficient flow at eye/face washes only.	6. Probable clogging of flow control due to inadequate line flushing. Turn water supply off. Unscrew eye/face wash head and adapter to gain access and clean flow control.
7. Insufficient water flow at the showerhead, however, eye/face wash is sufficient.	7. Probable clogging of flow control inside showerhead. Unscrew showerhead off of elbow and clean rubber flow control.

## TROUBLESHOOTING (Continued)

PROBLEM	REPAIR CHECKLIST
8. Shower and eye/face wash valve stem leak.	8. Remove shower arm or eye/face wash push flag. Peel black trim strip from shower and separate housing halves. Peel back or remove insulation to gain access to valve. Remove "U" bracket from valve stem and tighten valve stem hex packing nut to stop leak. Reassemble bracket, insulation, shower housing and valve arm.
9. Shower and eye/face wash valve leaks. (Does not shut off completely).	9. Disconnect power to unit. Disassemble as in item 6. Check valve arm stop tang for damage. Repair or replace valve assembly. Heat cable is looped around valve and should be pulled away from valve. Remove valve. Reverse above steps to reassemble.

For more information on Haws Products, please see our website: [www.hawesco.com](http://www.hawesco.com)

# PARTS BREAKDOWN

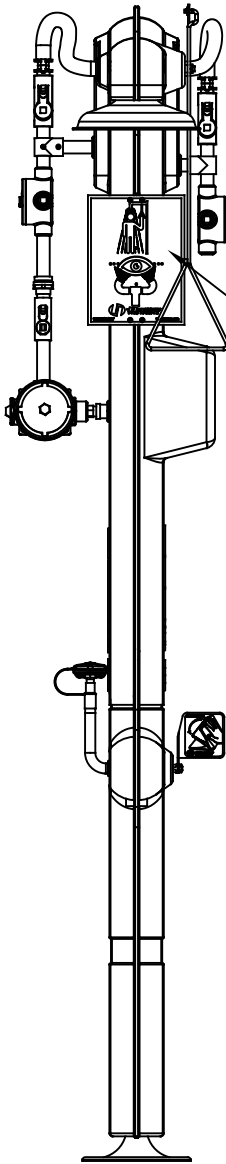

**FRONT VIEW**

SP178  
SHOWER/EYEWASH  
SIGN

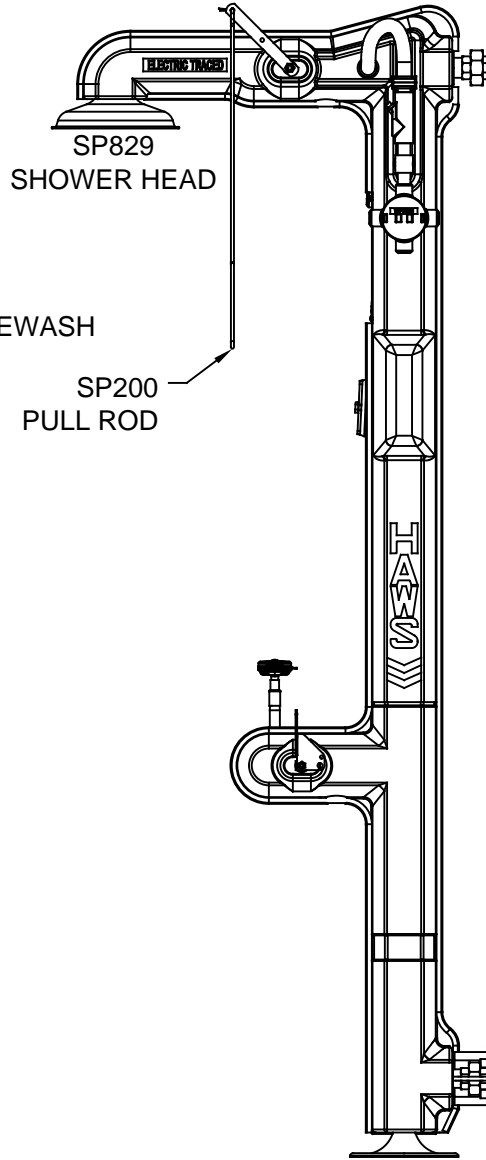

**SIDE VIEW**

SP829  
SHOWER HEAD

SP200  
PULL ROD

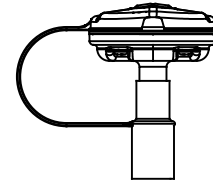

**SP65CTFP EYE/FACE WASH ASSEMBLY**

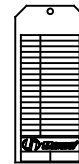

**SP170 TEST TAG**

SP158B FREEZE PROTECTION VALVE (SEE PAGES 8 & 9 FOR ADDITIONAL COMPONENTS)

WHEN ORDERING PARTS PLEASE SPECIFY MODEL NUMBER.

 <b>Haws</b> <sup>®</sup>		1455 KLEPPE LANE SPARKS, NEVADA 89431 (775) 359-4712 FAX (775) 359-7424 E-MAIL: HAWS@HAWSCO.COM WEBSITE: WWW.HAWSCO.COM	
		ECN NO. 4140 ECN: 5241 DRAWN SLS APPROVED FV	REVISED PER VWC DATE 7/16/08 CHKD VWC DATE 11/23/17
SCALE: 1:1		DRAWING TYPE: PARTS BREAKDOWN	SIZE: A SHEET 1 OF 1

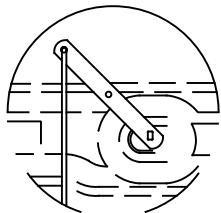
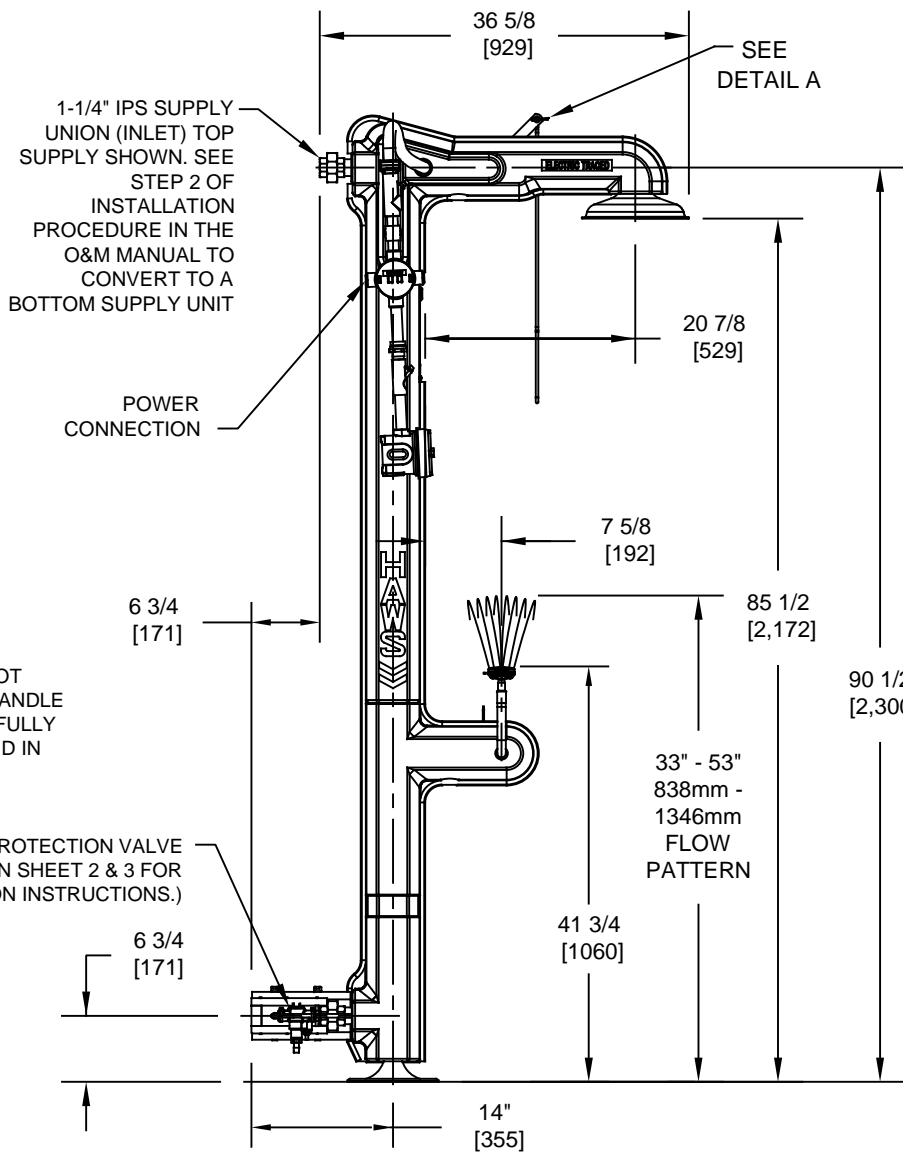

**DETAIL A**  
VIEW ROTATED 180°

NOTE: PULL ROD AND HANDLE NOT ASSEMBLED. ORIENTATION OF HANDLE MUST BE IN UP POSITION WHEN FULLY CLOSED AND PULL ROD INSERTED IN HOLE SHOWN.

SP158B FREEZE PROTECTION VALVE (SEE NOTES ON SHEET 2 & 3 FOR INSTALLATION INSTRUCTIONS.)

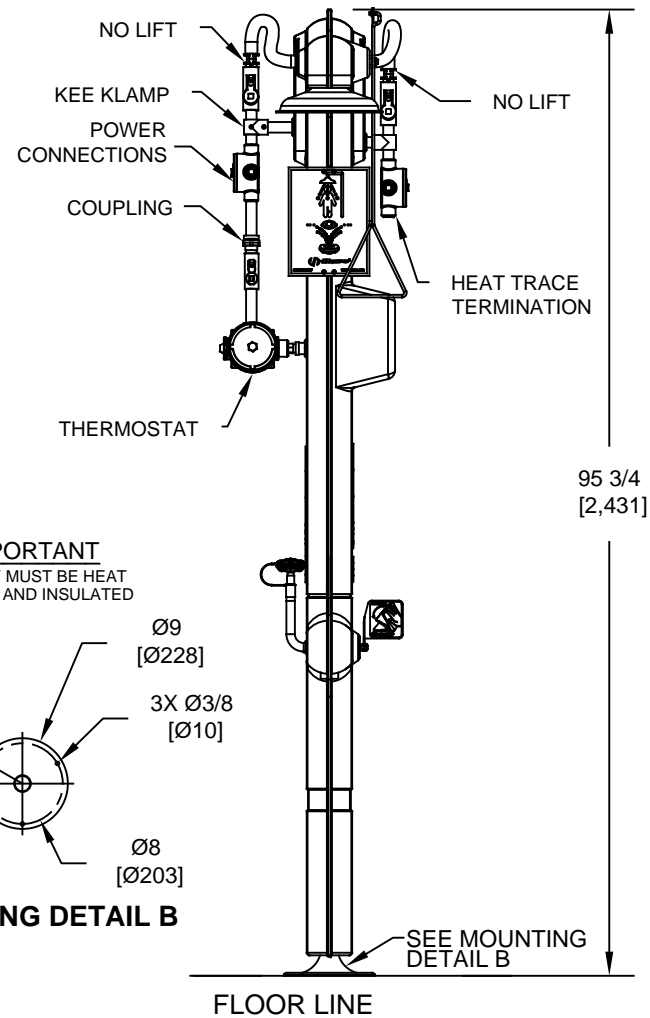

**IMPORTANT**  
SUPPLY MUST BE HEAT TRACED AND INSULATED

**NOTES:**

- WHEN INSTALLING THIS UNIT, LOCAL, STATE, OR FEDERAL CODES SHOULD BE ADHERED TO FOR INSTALLATION DIMENSIONS (LOCATIONS), WASTE AND SUPPLY REQUIREMENTS OTHER THAN SHOWN.
- TO COMPLY WITH ANSI Z358.1-2014 FOR EMERGENCY EYEWASH OR EYE/FACE WASH:
  - EYEWASH OR EYE/FACE WASH SHALL BE POSITIONED SUCH THAT FLUSHING FLUID PATTERN IS NOT LESS THAN 33" (838mm) AND NO GREATER THAN 53" (1346mm) FROM SURFACE ON WHICH USER STANDS; AND 6.0" (153mm) MINIMUM FROM WALL OR NEAREST OBSTRUCTION.
  - SHOWER SHALL BE POSITIONED SUCH THAT SHOWER HEAD IS NOT LESS THAN 82" (2083mm) AND NO GREATER THAN 96" (2438mm) FROM SURFACE ON WHICH USER STANDS.
  - SHOWER SPRAY PATTERN SHALL HAVE A MINIMUM DIAMETER OF 20" (508mm) AT 60" (1524mm) ABOVE SURFACE ON WHICH USER STANDS. CENTER OF SPRAY PATTERN SHALL BE LOCATED AT LEAST 16" (406mm) FROM ANY OBSTRUCTION.
- DIMENSIONS IN BRACKETS ARE IN MILLIMETERS.
- DIMENSIONS MAY VARY BY ±1/2" (13 mm).

		1455 KLEPPE LANE SPARKS, NEVADA 89431 (775) 359-4712 FAX (775) 359-7424 E-MAIL: HAWS@HAWSO.COM WEBSITE: WWW.HAWSO.COM	
		ECN NO. 4140 DRAWN: SLS APPROVED: FV	REVISED PER: ECN: 5241 DATE: 7/17/08 DATE: 11/23/17
PART NUMBER 0002077032.D			REVISION 11
SCALE: 1:1		DRAWING TYPE: INSTALLATION	SIZE: A SHEET 1 OF 4

NOTES: (CONTINUED FROM SHEET 1 OF 4)

4. FREEZE PROTECTION VALVE INSTALLATION INSTRUCTIONS:

- A** INSTALL VALVE SUB-ASSEMBLY INTO FEMALE SECTION OF UNION AND TIGHTEN WATER-TIGHT.
- B** FORM HEAT TRACE CABLE AROUND VALVE AND PLUG, APPLY 2X CABLE-TIES TO HEAT TRACE CABLE, AS SHOWN, ENSURING THAT HEAT TRACE CABLE IS PRESSED FIRMLY AGAINST SIDES OF VALVE (PUSH ANY LOOSE HEAT TRACE CABLE BACK INSIDE JACKET THROUGH RUBBER GROMMET). TRIM EXCESS CABLE-TIE STRAPPING.
- C** SLIDE INNER TUBE W/ PLUGGED END OVER VALVE WITH ADHESIVE SEAM FACING BOTTOM AND NON-PLUGGED END OF TUBE BUTTED UP AGAINST UNION SURFACE. REMOVE 2X ADHESIVE TAPE FROM SEAM AND SQUEEZE ADHESIVE SEAMS TOGETHER AROUND VALVE. APPLY 2X CABLE-TIES TO TUBE, IN APPROXIMATE LOCATIONS SHOWN. TRIM EXCESS CABLE-TIE STRAPPING.

(NOTES CONTINUED ON SHEET 3 OF 4)

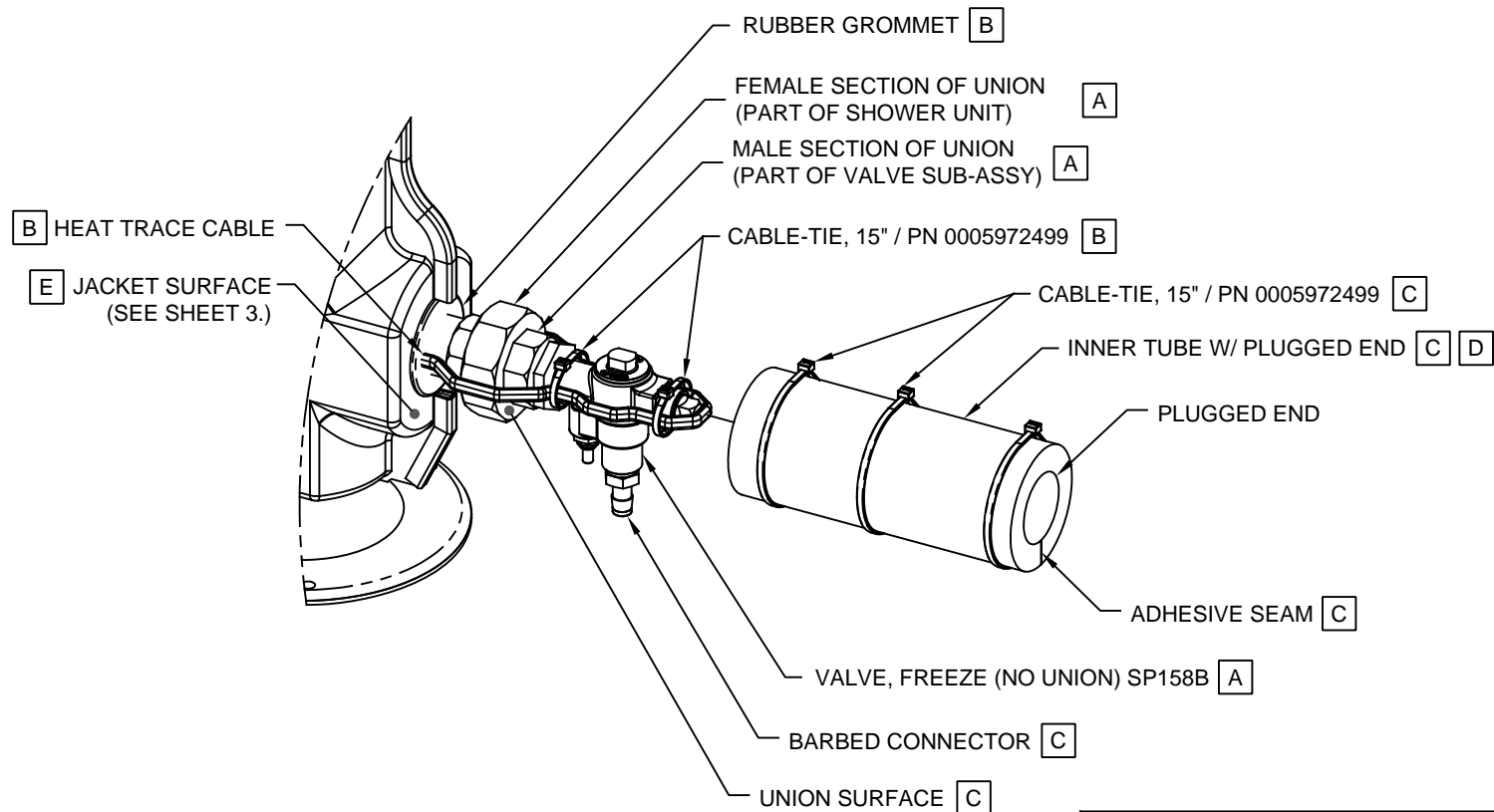

SP158B VALVE SHOWN CONNECTED TO BOTTOM UNION FOR REFERENCE ONLY. VALVE CAN BE INSTALLED AT TOP OR BOTTOM.

		1455 KLEPPE LANE SPARKS, NEVADA 89431 (775) 359-4712 FAX (775) 359-7424 E-MAIL: HAWS@HAWSO.COM WEBSITE: WWW.HAWSO.COM	
		ECN NO. 4632 DRAWN: VWC APPROVED: FV	REVISED PER BY: VWC ECN: 5241 DATE: 12/2/12 DATE: 11/23/17
SCALE: 1:1		DRAWING TYPE: INSTALLATION	SIZE: A SHEET 2 OF 4





NOTES: (CONTINUED FROM SHEET 2 OF 4)

5. FREEZE PROTECTION VALVE INSTALLATION INSTRUCTIONS (CONTINUED):

**D** WRAP OUTER TUBE OVER INNER TUBE ENCAPSULATED VALVE WITH ADHESIVE SEAM ORIENTED PERPENDICULAR TO SEAM OF INNER TUBE. PUSH OUTER TUBE UP AGAINST JACKET SURFACE. WHEN TUBE IS MOUNTED FIRMLY AGAINST JACKET SURFACE, SQUEEZE TUBE AT BARBED CONNECTOR SUCH THAT BARBED NIPPLE PUSHES THROUGH OUTER TUBE WALL. (PUSHING CONNECTOR THROUGH WALL WILL EXTRUDE A CYLINDRICAL PLUG OF TUBING TO BREAK FREE. DISCARD PLUG.) PUSH TUBE DOWN EVEN FURTHER SO THAT HOLE IN TUBE STRETCHES AROUND HEXAGONAL BOSS OF CONNECTOR. SQUEEZE OUTER TUBE TIGHT UNTIL ADHESIVE SEAMS ARE CLOSE ENOUGH TO SEAL. REMOVE PROTECTIVE TAPE AND SEAL SEAMS.

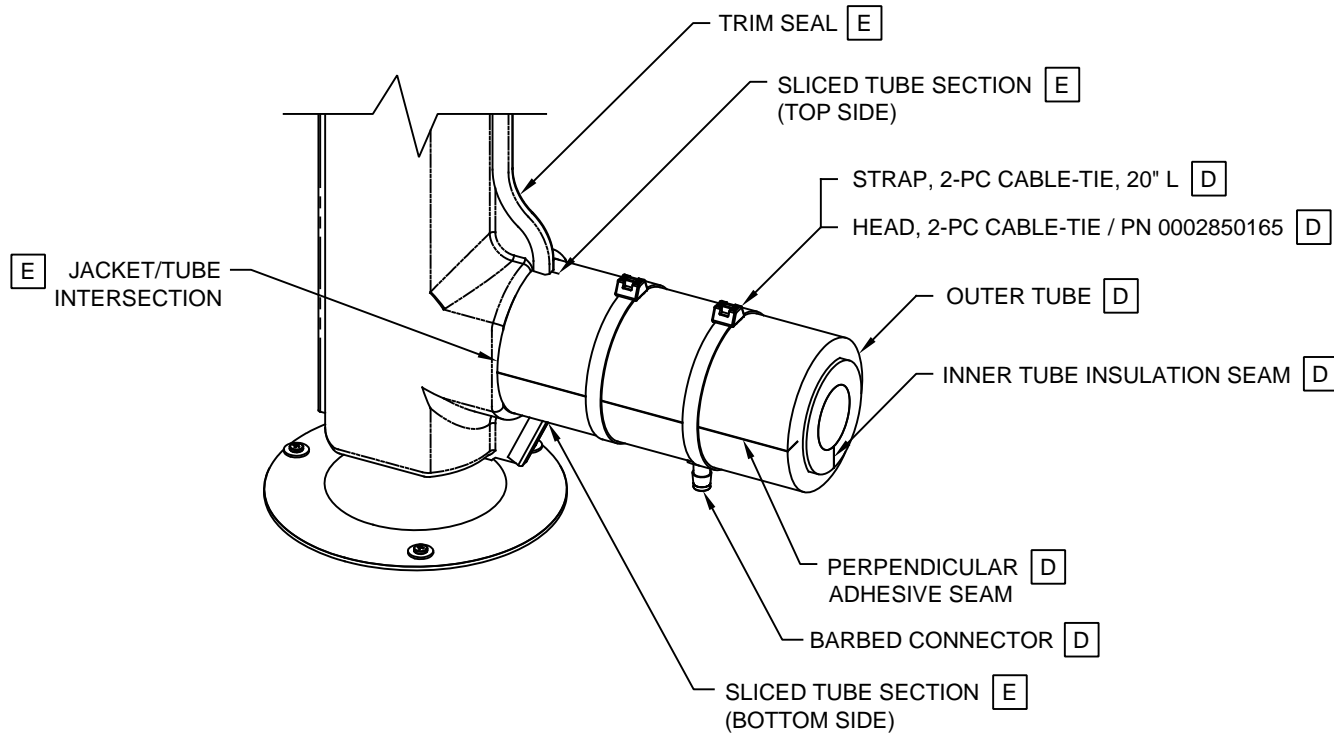
**E** TO ENSURE PROPER INSULATION OF UNION; THERE MUST BE NO SPACE BETWEEN OUTER TUBE AND JACKET SURFACE (SEE SHEET 2 FOR SURFACE CALLOUT). THEREFORE, SLICE TWO PLACES, TOP SIDE AND BOTTOM SIDE, COMPLETELY THROUGH OUTER TUBE TO A LENGTH EQUAL TO DEPTH OF TRIM SEAL. FORCE SLICED TUBE AROUND TRIM SEAL AND PUSH TUBE TIGHTLY AGAINST JACKET, AS SHOWN. APPLY 2X CABLE-TIE HEAD, AND 2X CABLE-TIE STRAP, TO TUBE, IN APPROXIMATE LOCATIONS SHOWN. TRIM EXCESS STRAPPING.



			1455 KLEPPE LANE SPARKS, NEVADA 89431 (775) 359-4712 FAX (775) 359-7424 E-MAIL: HAWS@HAWS.CO.COM WEBSITE: WWW.HAWS.CO.COM	
ECN NO. 4632	REVISED PER ECN: 5241	BY: VWC	MODEL(S)	PART NUMBER
			8317CTFPC1D1	0002077032.D
DRAWN: VWC	DATE: 12/2/12	CHKD.: VWC		REVISION
				11
APPROVED: FV	DATE: 11/23/17	SCALE: 1:1	DRAWING TYPE: INSTALLATION	SIZE: A SHEET 3 OF 4

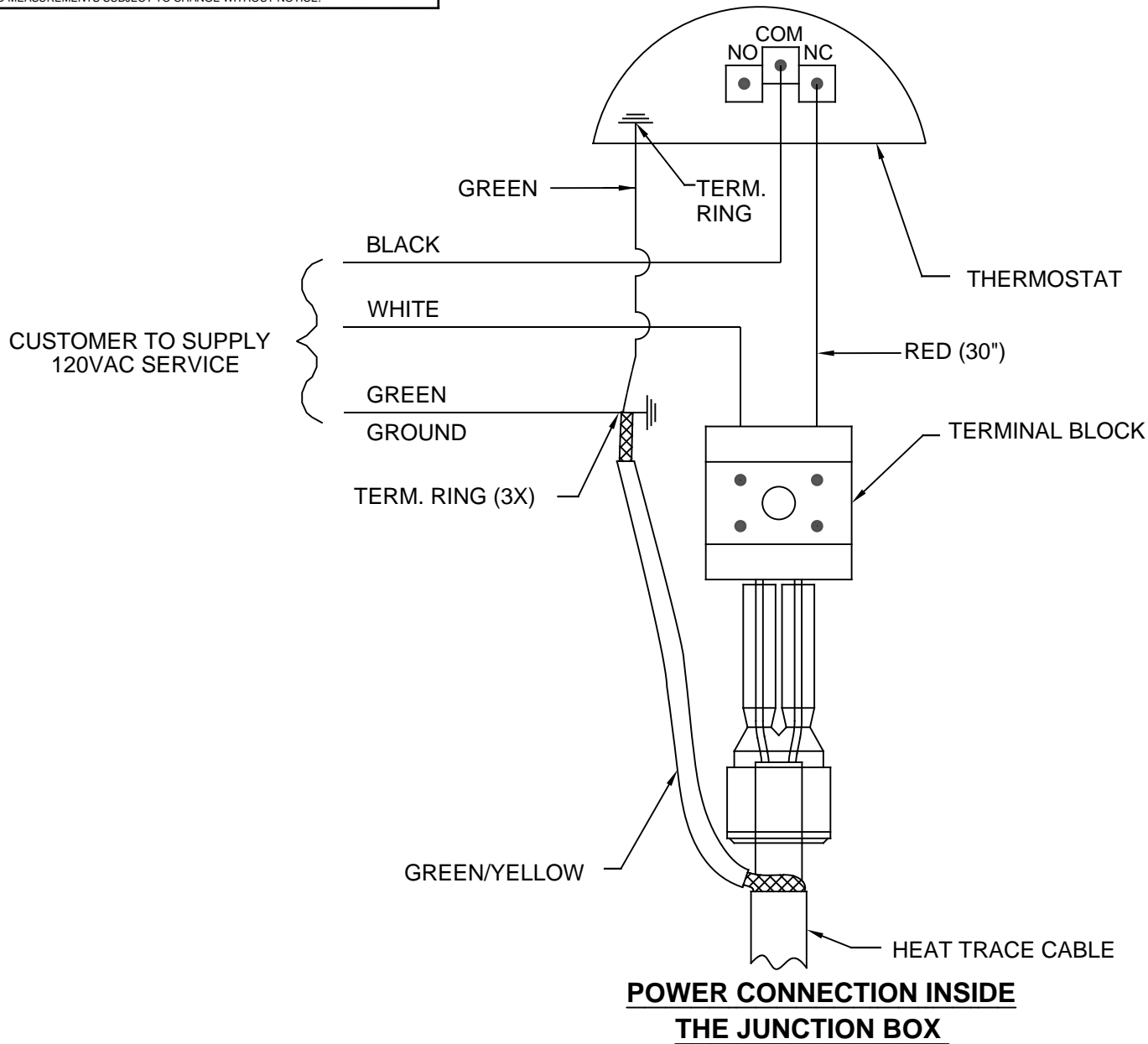

# ELECTRICAL SCHEMATIC

 <b>Haws</b> <sup>®</sup>		1455 KLEPPE LANE SPARKS, NEVADA 89431 (775) 359-4712 FAX (775) 359-7424 E-MAIL: HAWS@HAWS.CO.COM WEBSITE: WWW.HAWS.CO.COM	
		ECN NO: 4140 DRAWN: SLS APPROVED: FV	REVISED PER: ECN: 5241 DATE: 7/17/08 DATE: 11/23/17
PART NUMBER 0002077032.D			REVISION 11
SCALE: 1:1		DRAWING TYPE: INSTALLATION	SIZE: A SHEET 4 OF 4