

Model 215B V-Ball

Bulletin SS03043 Issue/Rev. 0.5 (8/17)

Smith Meter® Valves

The **Smith Meter® Model 215B Digital Control Valve** is a high-performance segmented equal percent, V-Ball valve with a solenoid-controlled pneumatic/hydraulic actuator.

When used in conjunction with a Smith Meter Electronic Valve Controller (e.g., AccuLoad®, or microLoad.net), the Model 215B Valve provides precise, trouble-free, low pressure drop, preset loading, and/or flow control of virtually any flowing liquid. The Smith Meter Model 215B V-Ball valves are ideal for controlling product flow at very low flow rates, which minimizes cavitation.

Features

- **Operation is independent of fluid viscosity and pressure** to assure proper control under virtually all operating conditions.
- **Wide fluid compatibility** can be assured by proper selection of valve-wetted materials.
- **Fail-safe** operation since valves are spring-loaded fail-to-close.
- **Class V shut-off classification.**
- **Pre-wired, explosion-proof junction box** supplied as standard.

Optional

- Pneumatic or hydraulic actuation
- Pressure regulator
- Pressure gauge
- Limit switches
- Hydraulic power pack

Operations

The valve schematic in Figure 1 illustrates the simplicity of the solenoid-controlled pneumatic/hydraulic actuator system of the Model 215B Valve. The normally closed (N.C.) and normally open (N.O.) solenoids, located on the pressure and relief lines (respectively) of the actuator, control the operation of the valve. Opening the pressure line and closing the relief line, by energizing both solenoids, allows



high pressure air or hydraulic fluid to enter the actuator, pushing the diaphragm and opening the valve. Conversely, de-energizing both solenoids allows the pressure in the actuator to relieve to atmosphere or back to the hydraulic reservoir, permitting the actuator spring to close the valve. Closing off both the pressure and relief lines (energizing the N.O. solenoid only) locks the valve in place. The needle valve settings control the valve opening and closing speeds.

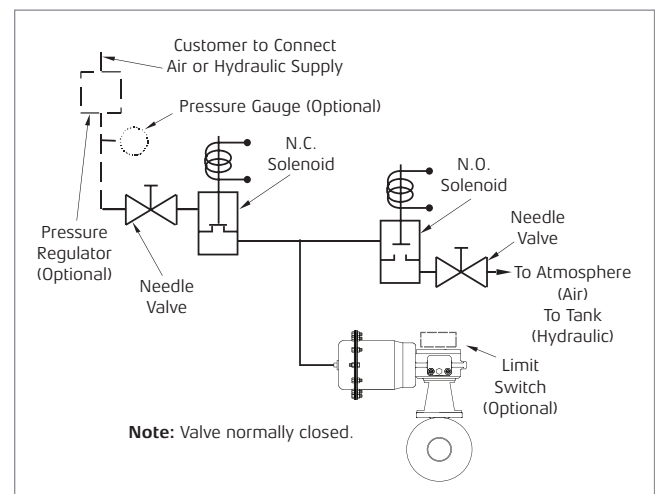

Figure 1 – Model 215B Valve Schematic

Specifications

Main Valve

Type: High-performance segmented equal percent, V-Ball valve.

Sizes: 1", 1-1/2", 2" and 3", Class 150 ANSI RF.

Pressure derated per ANSI B16.5 for temperatures greater than 100°F.

Temperature	
Ambient temperature range:	-20°F to 125°F (-29°C to 52°C)
Operating Temperatures range:	-20°F to 150°F (-29°C to 66°C) ¹

Operating Pressures

285 psig (Class 150 ASME) – standard at 100°F.

Other pressures available on request.

Materials of Construction	
Body:	Carbon Steel
Ball and Shaft:	Stainless Steel
Seat:	PTFE ²

Others materials available on request.

Actuator

Type: Spring – diaphragm

Materials of Construction:

Body – Carbon steel

Diaphragm – Buna-N

Air Supply: Clean, dry air or gaseous nitrogen

Hydraulic Supply: Mineral-based hydraulic fluid or equivalent

Operating Pressure: 100 psig maximum, 60-85 psig normal

Operating Temperature: -20°F to 150°F (-29°C to 66°C)

Needle Valve

Material: Brass – standard

Stainless Steel – optional

Tubing and Fittings

Material: Brass – standard

Stainless Steel – optional

Optional Equipment

Pressure regulator: 0-250 psi (air only)

Pressure gauge: 0-160 psi

Optional limit switches: Two SPDT, UL-listed, CSA certified FM approved. (NEMA 4, 7 Groups C and D, and 9 Groups E, F, and G) for combined watertight and hazardous location design. Switches are rated at 15A with 125/250 VAC and 0.5A DC resistive.

Hydraulic Power Pack:

- 110/240 VAC 50/60 Hz single phase
- 1 HP explosion proof motor – Class I, Div I Groups C&D
- 3.0 GPM gear pump for fast response
- Hydraulic supply and return manifolds – Drives up to six valve actuators.
- Size 3/8" SAE for supply and 1/2" SAE for return.
- Five gallon reservoir – with top filler/breather, drain plug and sight-level (small footprint).
- Supply pressure regulator – with adjustable set point 0 to 200 psig with liquid filled gauge.
- On demand – Pump activates only when valve control is needed, used in conjunction with a Smith Meter AccuLoad or other preset controller.

Solenoids

Explosion-proof, UL-listed, CSA certified, FM approved, meets CE directives for NEMA 4 and 7, Groups C and D, for use in watertight and hazardous locations.

Type: 2-way normally closed on pressure line

2-way normally open on exhaust line

Materials of Construction	
Standard	Brass with Buna-N disk
Optional	Stainless Steel with Viton disk for service in corrosive atmosphere

Operating Pressure: 85 psi maximum

Voltage	
Standard	102-120 VAC 60 Hz
	94-110 VAC 50 Hz
	204-240 VAC 60 Hz
	188-220 VAC 50 Hz
Optional	20-25 VDC
	10.2-12.6 VDC

Other voltages: Consult factory

Applications: Open or closed position indication for signaling devices, panel light operation, etc.

Valve open position limiting to facilitate prompt valve closure in dedicated service where an AccuLoad or microLoad.net is not required.

¹ Higher temperatures available with decrease in maximum working pressure.

² Polytetrafluoroethylene (PTFE)

Hybrid/Ratio Blending System Configuration

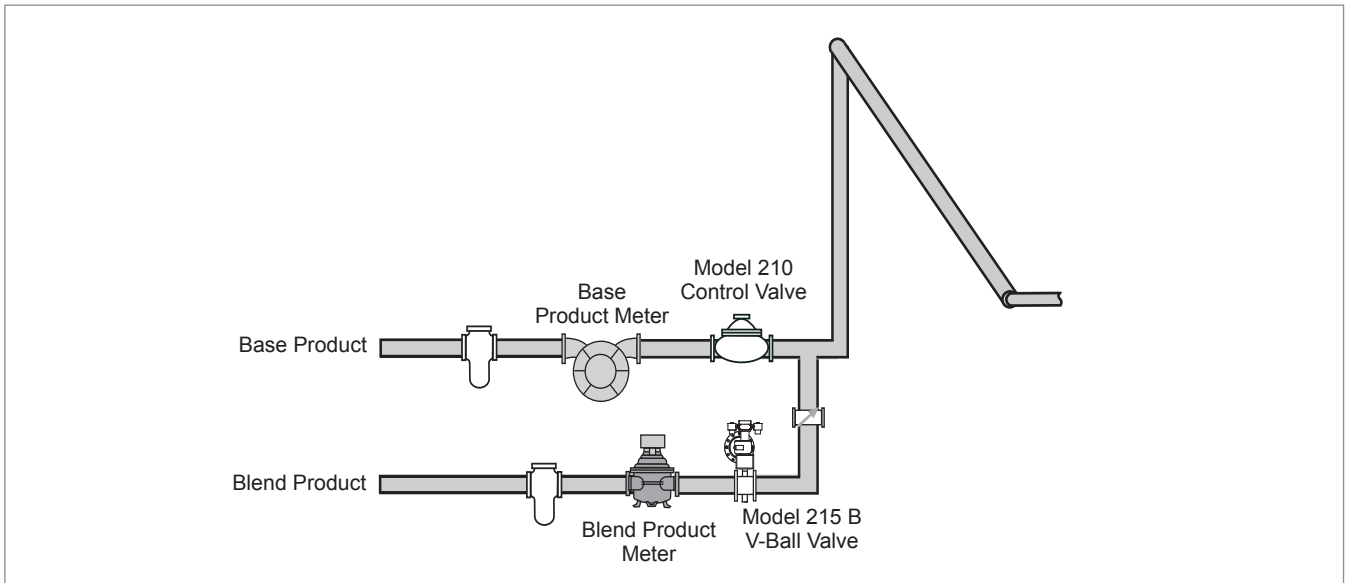

Model 215B Selection Guide Diagram

Alternative fuel blending systems are comprised of many different configurations and are used over a wide range of operating conditions. Measurement Solutions business of TechnipFMC recommends the following valves for typical blend lines which have a relatively constant inlet pressure to 80 psi and outlet pressure to 15 psi and are delivering the product downstream of the line meter.

Line Size (Inches)	Bio-diesel Product Blend Ratio (%)	Flow Range (GPM)	Control Valve Size (Inches)
2	2% to 10%	3 to 75	1
2	10% to 20%	15 to 150	1 - 1/2
3	20% to 50%	30 to 325	2, 3

For other arrangement contact the factory and provide the following information: Product, Blend Ratios, Flow Rate Range, Upstream Pressure, Downstream Pressure.

Dimensions

Inches (Millimeters)

Note: Dimensions – inches to the nearest tenth (millimeters to the nearest whole mm), each independently dimensioned from respective engineering drawings.

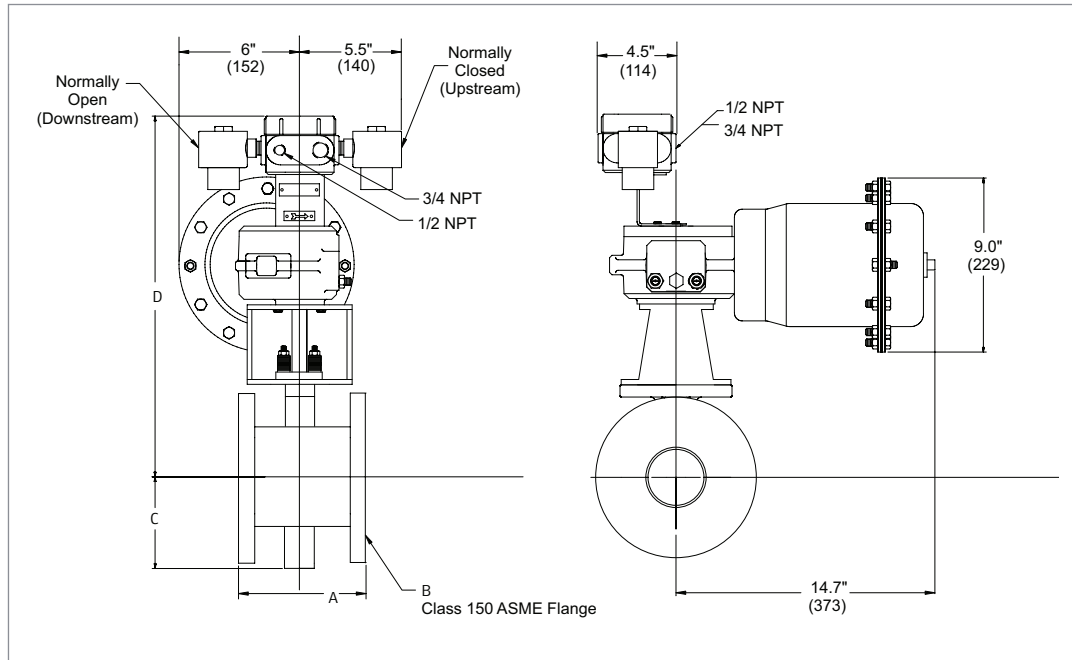

Valve Size	A		B Class 150 ASME Flange	C		D		Actuator Air Swept Volume (in ³)
	inches	mm		inches	mm	inches	mm	
1	4.0	102	1.0	2.2	56	17.1	435	66
1-1/2	4.5	114	1.5	2.6	65	17.4	442	66
2	4.9	124	2.0	3.6	91	17.8	453	66
3	6.5	165	3.0	4.3	108	18.7	475	66

CV

Size		Relative Opening									
DN	INCH	10%	20%	30%	40%	50%	60%	70%	80%	90%	100%
26	1	0.693	1.55	2.77	4.35	6.43	9.03	12.9	19.1	20.3	21
40	1.5	0.756	2.50	5.06	8.54	13.4	18.7	25.4	39.6	56.5	61
50	2	1.4	4.5	9.1	15.4	24.1	33.7	45.9	71.6	102	110
80	3	4.2	14	27	41	63	90	118	159	238	340

The specifications contained herein are subject to change without notice and any user of said specifications should verify from the manufacturer that the specifications are currently in effect. Otherwise, the manufacturer assumes no responsibility for the use of specifications which may have been changed and are no longer in effect.

Contact information is subject to change. For the most current contact information, visit our website at www.fmctechnologies.com/measurementsolutions and click on the "Contact Us" link in the left-hand column.

TechnipFMC.com

FMCTechnologies.com/MeasurementSolutions

© TechnipFMC 2017 SS03009 Issue/Rev. 1.1 (8/17)

TechnipFMC
FMC Technologies
Measurement Solutions, Inc.
500 North Sam Houston Parkway West,
Suite 100
Houston, Texas 77067 USA
P:+1 281.260.2190

USA Operation
1602 Wagner Avenue
Erie, Pennsylvania 16510 USA
P:+1 814.898.5000

Germany Operation
Smith Meter GmbH
Regentstrasse 1
25474 Ellerbek, Germany
P:+49 4101.304.0