



## TT 60 C/R HANDBOOK



Two-wire transmitter with Profibus-PA<sup>®</sup> interface



**Copyright**

All rights reserved. Any duplication of this documentation or extracts thereof by any means is prohibited without prior written consent from KROHNE Messtechnik GmbH.  
Subject to change without notice.

Copyright 2010 by  
KROHNE Messtechnik GmbH • Ludwig-Krohne-Straße 5 • 47058 Duisburg  
Tel. +49 (203) 301-0

<b>1</b>	<b>Safety information</b> .....	<b>4</b>
1.1	Intended use .....	4
1.2	Product liability and guarantee .....	4
1.3	Certifications .....	5
1.3.1	Certifications, PC connection cable, Type A .....	5
1.4	Manufacturer's safety instructions .....	5
1.4.1	Notes about the documentation .....	5
1.4.2	Symbol conventions .....	6
<b>2</b>	<b>Device description</b> .....	<b>7</b>
<b>3</b>	<b>Installation</b> .....	<b>8</b>
3.1	TT 60 C installation .....	8
3.2	TT 60 R installation .....	10
<b>4</b>	<b>Electrical connections</b> .....	<b>11</b>
4.1	Safety instructions .....	11
4.2	Connections .....	12
4.3	ProfiBus connection .....	13
4.3.1	Shielding and grounding .....	13
4.3.2	Cable parameters for areas with potentially explosive atmospheres .....	14
4.3.3	Terminator .....	15
4.3.4	ProfiBus architecture .....	15
4.4	TT 60 C connection diagram .....	16
4.5	TT 60 C  connection diagram .....	17
4.6	TT 60 R connection diagram .....	18
<b>5</b>	<b>Operation</b> .....	<b>19</b>
5.1	Connection using the KROHNE PC configuration set .....	19
5.2	General .....	20
5.2.1	Smart Sense .....	21
5.2.2	Monitoring of sensor aging .....	21
<b>6</b>	<b>Technical data</b> .....	<b>22</b>
6.1	TT 60 C specifications .....	22
6.1.1	Technical data .....	22
6.1.2	TT 60 C dimensions .....	23
6.1.3	Data inputs and outputs .....	23
6.1.4	Ambient temperature data for areas with potentially explosive atmospheres .....	23
6.2	TT 60 C  specifications .....	24
6.2.1	Technical data .....	24
6.2.2	TT 60 C  dimensions .....	25
6.2.3	Data inputs and outputs .....	25
6.2.4	Ambient temperature data for areas with potentially explosive atmospheres, .....	25
6.3	TT 60 R specifications .....	26
6.3.1	Technical data .....	26
6.3.2	TT 60 R dimensions .....	27
<b>7</b>	<b>Service</b> .....	<b>28</b>
7.1	Ordering information .....	28

## 1.1 Intended use

The TT 60 C is a two-wire universal transmitter with ProfiBus-PA® interface for temperature and other measurement applications. It is intended for installation in a B connection head or larger according to DIN 43729.

The TT 60 C is optionally available in an intrinsically safe version for installation in areas with potentially explosive atmospheres. These devices are labeled with the Ex symbol .

The TT 60 R is an intelligent, two-wire universal transmitter with ProfiBus-PA® interface for temperature and other measurement applications. It is only intended for installation on a top-hat rail according to DIN EN 50022.



### **ATTENTION!**

*Responsibility for the use of the measurement devices with regard to suitability, intended use and area of application lies solely with the user.*

The manufacturer shall not be liable for damage resulting from improper use or use for other than the intended purpose.

## 1.2 Product liability and guarantee

Use for other than the intended purpose or improper installation and operation may lead to loss of the guarantee. The guarantee shall likewise be void if the device is damaged or its function otherwise impaired.

KROHNE Messtechnik GmbH hereby guarantees that the product will be free of material and workmanship defects for a period of five (5) years from the date of delivery ("limited guarantee"). This limited guarantee refers to repairs or exchanges, and is only valid for the first end user of the product.

The "General conditions of sale" forming the basis of the purchase contract are also applicable.

## 1.3 Certifications

Approval Demko 06 ATEX 141336X

TT 60 C: CE  II 3G EEx nL IIC

TT 60 C Ex: CE 0102  II 1G Ex ia IIC



### **IMPORTANT NOTE!**

*See also the ATEX certificate "Special conditions for safe use".*

The measuring device complies with the statutory requirements of the following EC directives:  
The manufacturer's declaration can be viewed on the Internet at

<http://www.krohne.com/html/dlc/index.shtml>.

KROHNE Messtechnik GmbH certifies successful testing of the product by applying the CE mark.

### 1.3.1 Certifications, PC connection cable, Type A

Approval Demko 06 ATEX 141337X

## 1.4 Manufacturer's safety instructions

The measuring device has been built and tested in accordance with the current state of the art, and complies with the relevant safety standards.  
However, dangers may arise from improper use or use for other than the intended purpose. For this reason, observe all of the safety instructions in this document carefully.

### 1.4.1 Notes about the documentation

In addition to the safety rules and industrial safety regulations in this documentation, national and regional safety rules and industrial safety regulations must also be observed.

### 1.4.2 Symbol conventions

For greater clarity, the following symbols are used in this documentation:



***DANGER!, WARNING!, ATTENTION!, CAUTION!***

*This symbol indicates general dangers.*

*All warnings must always be observed. Even partial failure on your part to observe them can lead to serious damage to health, damage to the device or to the user's system components.*



***DANGER!***

*This symbol is used to identify dangers when working with electric current.*

*Work on the device's electrical and electronic components may only be performed by qualified personnel with the appropriate training.*



***DANGER!***

*This symbol indicates dangers in areas with potentially explosive atmospheres, for example those which may arise during installation and operation of explosion-proof devices.*

*Special regulations apply for use in areas with potentially explosive atmospheres; these must always be observed in order to ensure safe use in such areas. Installation, set-up, operation and maintenance of the device may only be performed by qualified persons with training in explosion protection.*



***Important note!, Note!, Information!***

*This symbol identifies important notes and information for working with the device.*



***Legal note!***

*This symbol identifies references to legal and normative regulations.*



***Action***

*This symbol identifies all instructions for actions; the actions must be performed by the user in the specified sequence.*



***Effect***

*This symbol identifies all of the important effects of the previous actions.*

The KROHNE TT 60 C/R is two-wire universal transmitter with ProfiBus-PA® interface for

- Temperature measurements with resistance thermometers
- Temperature measurements with thermocouples
- Temperature differential measurements with resistance thermometers
- Measurements with potentiometers
- Voltage measurements in a range from -10...1000 mV

The transmitter supports two input signals, thus allowing differential, average and redundant measurements and monitoring of sensor aging.

The TT 60 C is optionally available for areas with potentially explosive atmospheres.

The two-wire universal transmitter TT 60 C is designed for installation in a B connection head according to DIN 43729 or larger.

The two-wire universal transmitter TT 60 R is designed for installation on a top-hat rail according to DIN EN 50022 .

The output of all versions of the TT 60 complies with the latest ProfiBus PA® standard for temperature measuring transducers, i.e. Profile 3.0, Class A and B.

The transmitter can be configured using ProfiBus-PA® or an IBM-compatible PC. Configuration of the transmitter using an IBM-compatible PC requires the "ProfiSoft" software.

The Windows-based "ProfiSoft" software can be used to access all functions of the transmitter.

The current software version is available for downloading on our website

<http://www.krohne.com/html/dlc/index.shtml>.

You can find configuration instructions in the "ProfiSoft" reference manual.

### 3.1 TT 60 C installation

TT 60 C / TT 60 C  are intended for installation in DIN B connection heads or larger. The large  $\varnothing$  7 mm / 0.28 inch center hole (see Chapter 6.1.2) facilitates the electrical connection and installation.



**ATTENTION!**

The TT 60 C  may only be installed in a light metal housing whose magnesium component (Mg) does not exceed 6%.

For applications in a safe area, a housing according to IP 54 is recommended.



**ATTENTION!**

The TT 60 C may only be installed in areas with potentially explosive atmospheres Zone 2 and in safe areas. If it is installed in Zone 2, a housing with at least IP 54 must be used.

In areas with potentially explosive atmospheres Zone 0 and Zone 1, the TT 60 C  must be used.

The transmitter must be supplied with power by an intrinsically safe power supply unit or Zener barrier outside of the potentially explosive zone.



**ATTENTION!**

The TT 60 C  must be installed in a housing with the protection rating IP 20 or better.

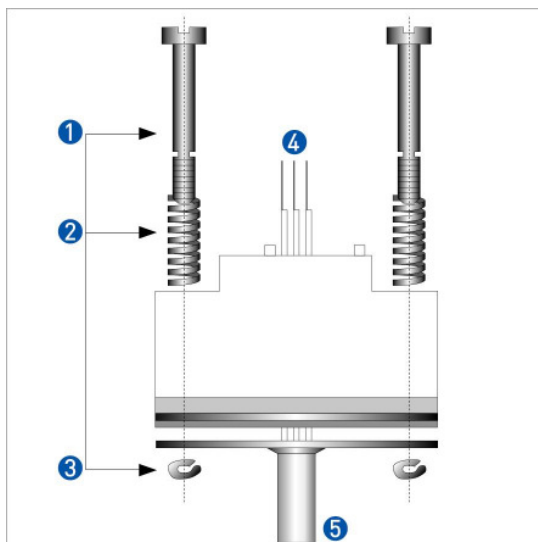

Figure 1: Connection head installation kit VI70ADA00017

- 1 Screw M4
- 2 Spring
- 3 Lock washer
- 4 Measuring sensor
- 5 Protection tube



***IMPORTANT NOTE!*****Ambient temperature considerations**

The temperature transmitter TT 60 C has been developed for the ambient temperature range from -40...+ 85°C (-40...+185°F). Please also note that the ambient temperature is also dependent on the temperature category in Sections 6.1.4 and 6.2.4, Ex data of the ambient temperature.

The process temperature is also transferred to the transmitter housing via the protective tube. If the process temperature is close to or exceeds the maximum specified process temperature, then the temperature in the transmitter housing can rise above the maximum permissible ambient temperature.

Always check that the ambient temperature where the transmitter is installed is always within the permissible range. One way to decrease heat transfer via the protective tube is to make the protective tube longer or in general to install the transmitter farther away from the heat source. The same safety measures can be taken if the temperature is below the specified minimum temperature.

### 3.2 TT 60 R installation

The TT 60 R transmitter is intended for installation on a top-hat rail according to DIN EN 50022.



**ATTENTION!**

*The TT 60 R may not be installed for measurements in areas with potentially explosive atmospheres.*

*For measurements in areas with potentially explosive atmospheres, the TT 60 C  must be used.*

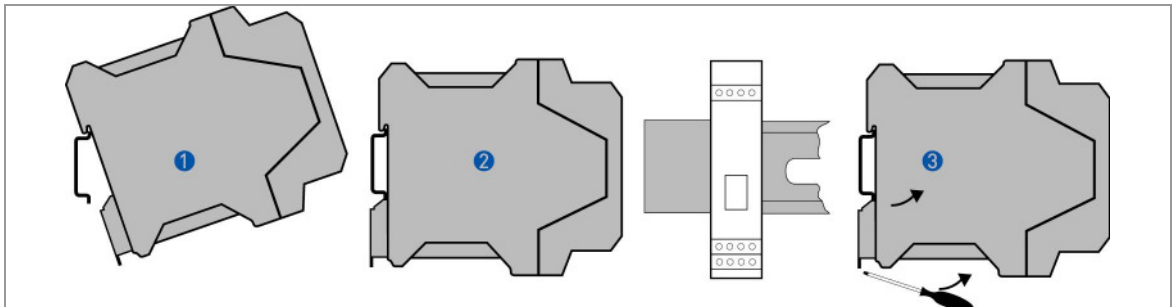

Figure 2: TT 60 R rail installation

- 1 Hook the upper groove of the transmitter onto the rail.
- 2 Press the transmitter downwards until the snap fastener engages on the rail.
- 3 To remove, press the snap fastener downwards using a screwdriver. Carefully pull the transmitter forwards.

### 4.1 Safety instructions

**ATTENTION!**

*Only trained and qualified personnel may carry out any work on the device. Always observe the regional industrial safety and other safety regulations.*

**ATTENTION!**

*Any work on the electrical connections may only be carried out in the de-energized state. Observe the voltage specifications on the rating plate!*

*Observe the national regulations for electrical installations!*

*The transmitter is protected against polarity reversal. No damage will occur to the device if the polarity of the supply voltage is switched.*

**ATTENTION!**

*When connecting devices with an Ex certificate, observe the corresponding chapters and the instructions in this manual.*

*The TT 60 C  may only be connected to sensors that meet the requirements for "simple equipment" in standard EN 50020:2002, section 5.4.*

*The transmitter must be supplied with power by an intrinsically safe power supply unit or Zener barrier outside of the potentially explosive zone.*

## 4.2 Connections

The input and output signals and the power supply must be connected in accordance with the following illustrations. The in-head transmitter is easy to install with the KROHNE connection head installation kit (see order information chapter 7.1). To avoid measuring errors, all cables must be connected properly and the screws tightened correctly.

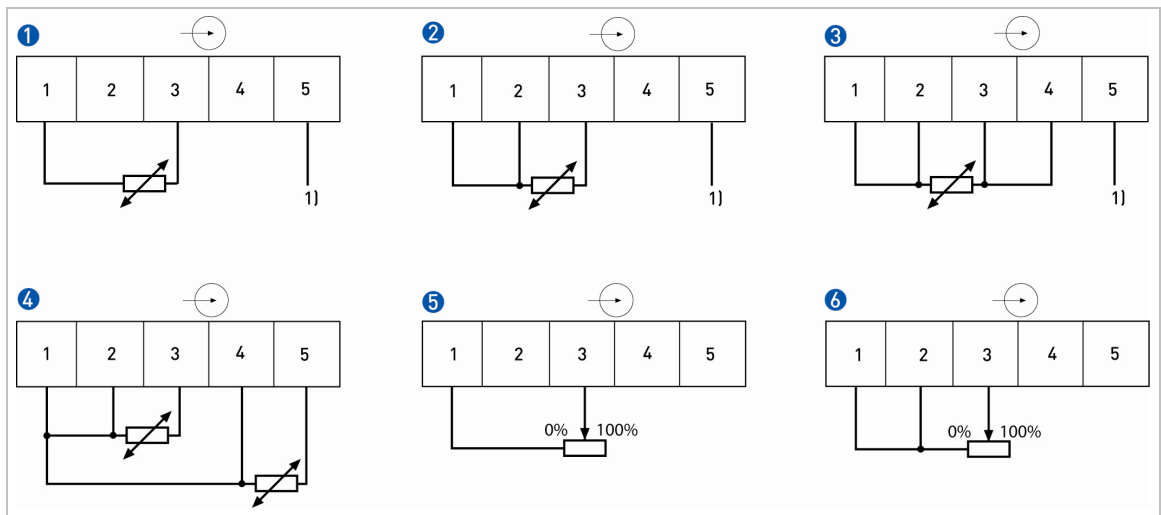

Figure 3: Installation diagram, TT 60 C/R

- 1 Pt100, Pt1000, Ni100, Ni1000, "SmartSense", 2-wire connection
- 2 Pt100, Pt1000, Ni100, Ni1000, "SmartSense", 3-wire connection
- 3 Pt100, Pt1000, Ni100, Ni1000, "SmartSense", 4-wire connection
- 4 Pt100, redundant sensor elements
- 5 Potentiometer, 2-wire connection
- 6 Potentiometer, 3-wire connection

1) SmartSense wire

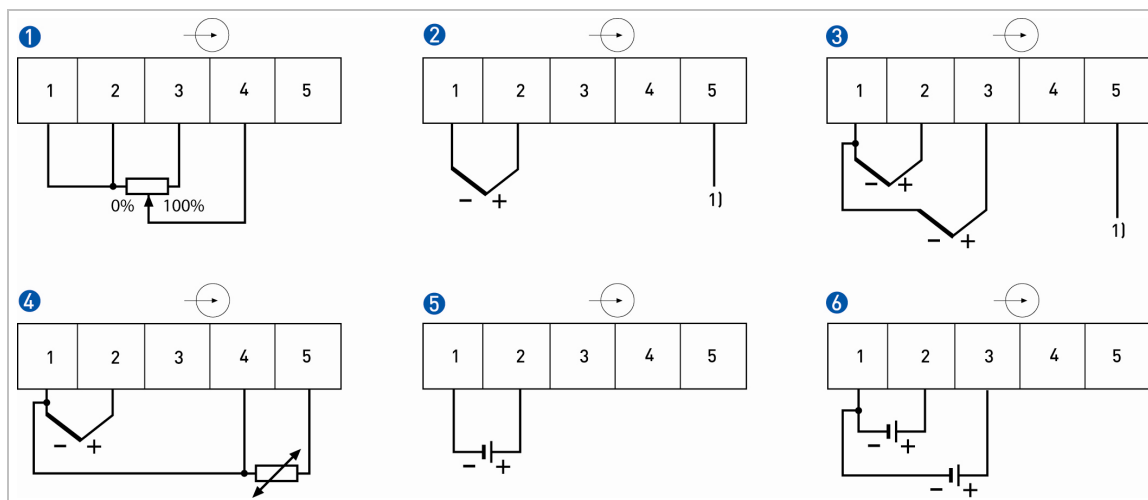

Figure 4: Installation diagram, TT 60 C/R

- 1 Potentiometer, 4-wire connection
- 2 Thermocouple
- 3 Thermocouple, redundant sensor elements
- 4 Thermocouple, with remote reference junction compensation
- 5 Voltage
- 6 Voltage, redundant

1) SmartSense wire

### 4.3 ProfiBus connection

#### 4.3.1 Shielding and grounding

In environments subject to electrical interference, shielded and twisted wires enable precise measurement results. The electrical wiring of the data bus must be installed properly and shielded in order to enable precise measurement results.



#### **IMPORTANT NOTE!**

*If you use non-shielded wires, they must not be laid near power cables or electrical loads.*

In order to ensure the electromagnetic compatibility of the entire measuring system, all components must be shielded and grounded. The shields and grounds must provide complete protection against interference.

**CAUTION!**

EN 61158-2 stipulates that all data bus interfaces must be isolated from the local ground.  
The ProfiBus must not be grounded.

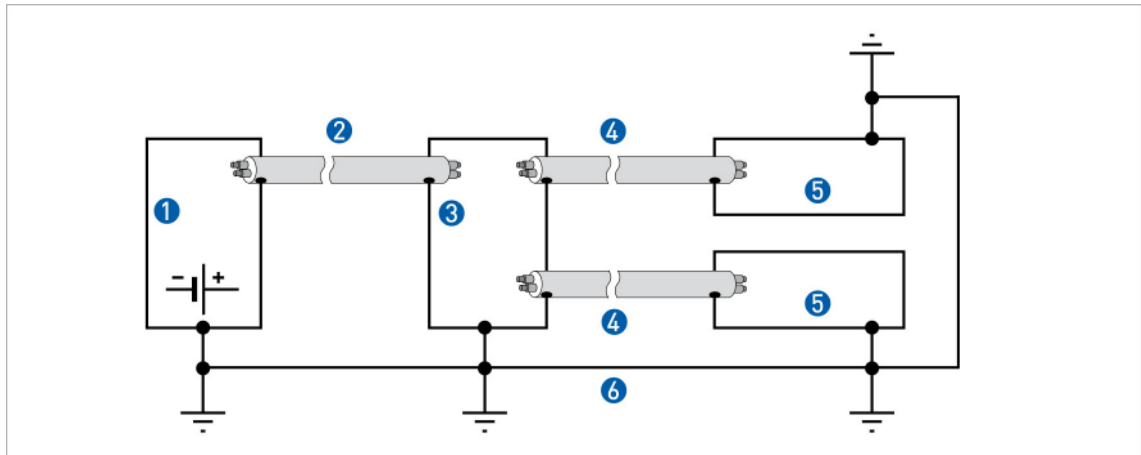

Figure 5: Circuit schematic, ProfiBus shielding and grounding

- 1 Power supply
- 2 Supply cable
- 3 Connection box
- 4 Connection cable to field device
- 5 Field device
- 6 Equipotential bonding

#### 4.3.2 Cable parameters for areas with potentially explosive atmospheres

Resistance	Values
Cable resistance	15...150 $\Omega$ /km
Cable inductance	0.4...1 mH/km
Cable capacitance	45...200 nF/km

### 4.3.3 Terminator

The ProfiBus cable must be terminated at both ends.  
The terminator consists of a capacitor and a film resistor connected in series.

	Values
(T)	$R = 100 \Omega \pm 2\%$
	$C = 1 \mu\text{F} \pm 20\%$

### 4.3.4 ProfiBus architecture

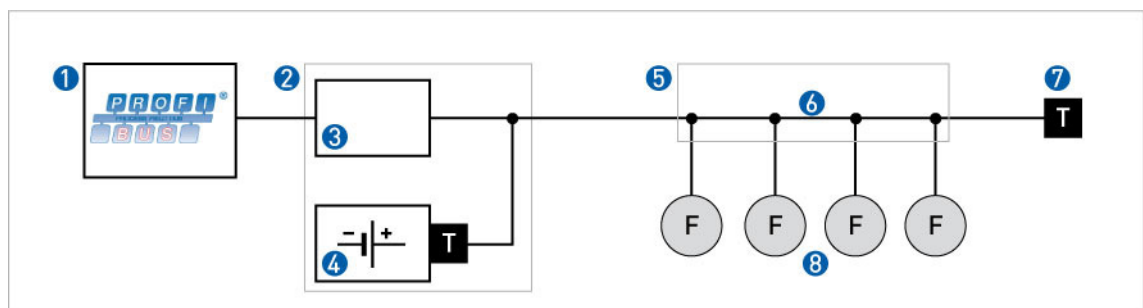

Figure 6: Typical ProfiBus architecture

- 1 ProfiBus DP components
- 2 DP/PA segment coupler with 3 and 4
- 3 Signal coupler
- 4 Power supply
- 5 Connection box
- 6 PA segment
- 7 Bus terminator
- 8 Field devices

The illustration above shows a typical ProfiBus architecture. Field devices with low power consumption (e.g. pressure and temperature transmitters) are fed via the two-wire bus. Signal transmission is likewise via the bus.

In the case of installations in areas without potentially explosive atmospheres, up to 32 devices can be connected per segment, depending on the power rating of the segment coupler.

In the case of installations in areas with potentially explosive atmospheres, normally 10 devices can be connected per segment.

4.4 TT 60 C connection diagram



**ATTENTION!**

The TT 60 C may only be operated in areas with potentially explosive atmospheres Zone 2 and in safe areas.

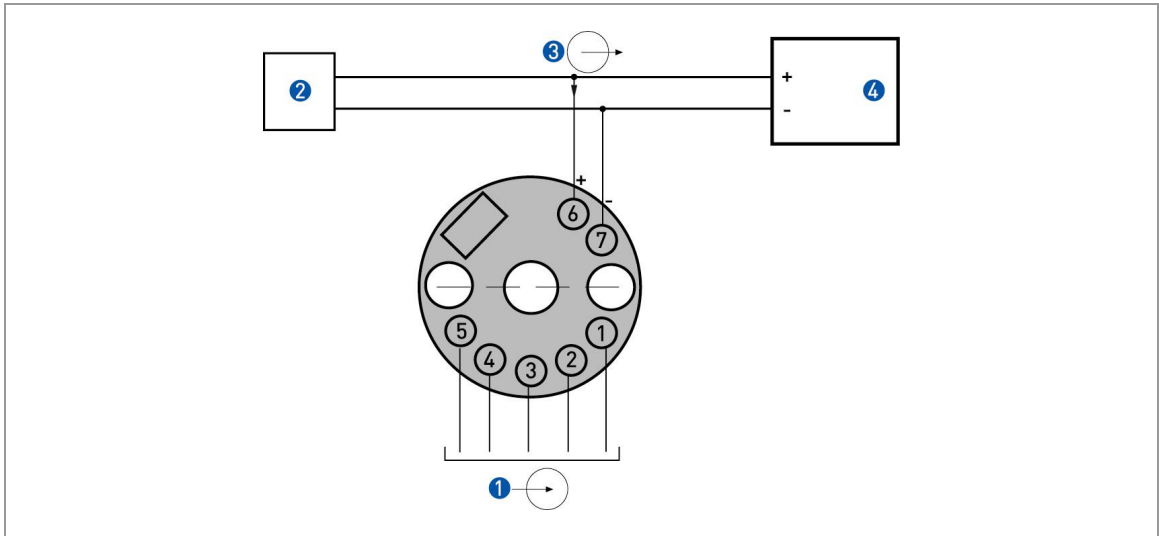

Figure 7: TT 60 C connection diagram

1	Input
2	Profibus PA® terminator
3	Profibus PA® output, bus lines
4	Bus feed unit / segment coupler (in the case of applications in areas with potentially explosive atmospheres, certified devices must be used)



4.5 TT 60 C<sup>Ex</sup> connection diagram**ATTENTION!**

The transmitter may be operated in areas with potentially explosive atmospheres if the voltage supply is ensured by means of an appropriate power supply unit or a Zener barrier!

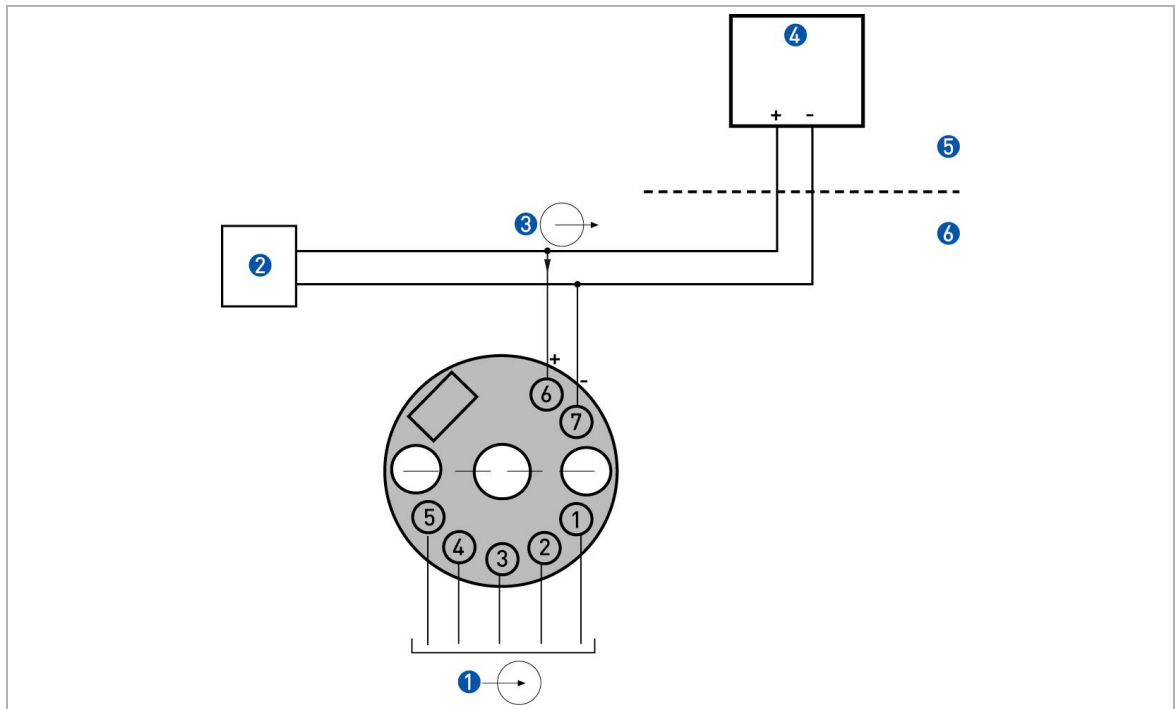

Figure 8: TT 60 C<sup>Ex</sup> connection diagram

1	Input
2	ProfiBus PA <sup>®</sup> terminator
3	ProfiBus PA <sup>®</sup> output, bus lines
4	Certified bus feed unit / segment coupler
5	Safe area
6	Area with potentially explosive atmosphere

4.6 TT 60 R connection diagram



**ATTENTION!**

*Neither install the transmitter in an area with a potentially explosive atmosphere, nor connect it to a sensor in an area with a potentially explosive atmosphere!*

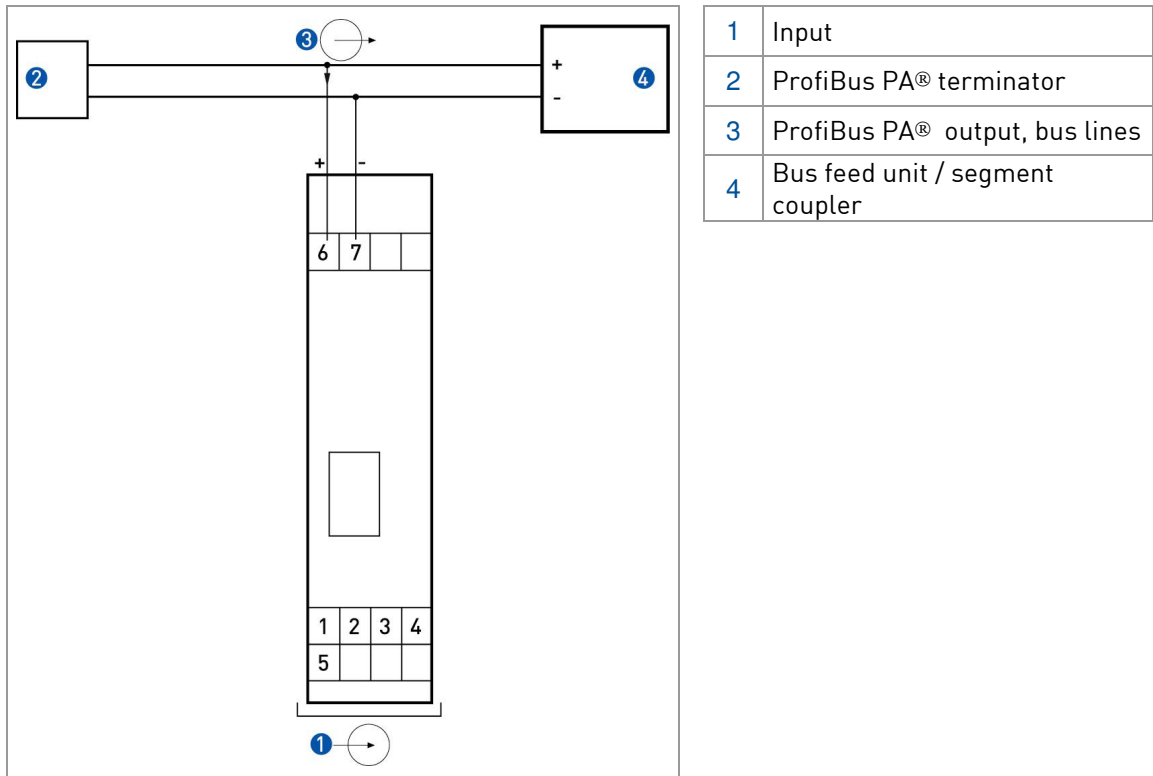

Figure 9: TT 60 R connection diagram

## 5.1 Connection using the KROHNE PC configuration set



### ATTENTION!

No PC may be connected to a transmitter in areas with potentially explosive atmospheres.

If you wish to configure the transmitter with the PC, this must be done outside of the area with a potentially explosive atmosphere or by means of communication via ProfiBus.

If the transmitter is configured with the PC, a configuration cable and an adapter from the configuration set (order number see Chapter 7.1) must be used as the connection between the PC and the transmitter.

An ATEX certified cable must be used for transmitters bearing the  symbol.

	Type A	Type C
TT 60 C	X	X
TT 60 C 	X	X
TT 60 R	X	X

Table 1: PC connection cable

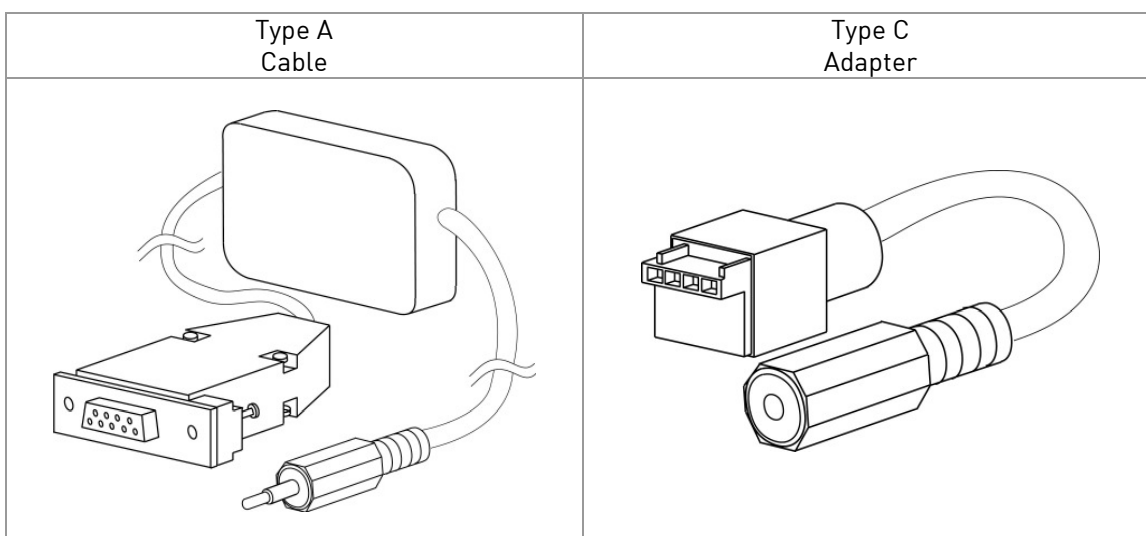

Figure 10: PC connection cable

	Order number	Comment
Type A (cable)	VI70IPRX0002	ATEX certified
Type C (adapter)	VI70IPRP0001	--

## 5.2 General

**IMPORTANT NOTE!**

*The TT 60 is shipped ex works with a standard configuration.*

**Standard settings:**

Address	126
Input signal	Pt100, 4-wire
Output signal	°C
Filter	0 s
Sensor monitoring	Off

All models of the TT 60 series have a ProfiBus PA<sup>®</sup>-interface. The transmitters can be configured using

- ProfiBus PA<sup>®</sup>-
- an IBM compatible PC.

With a PC, configuration can be carried out before the device is integrated into the ProfiBus. Configuration using a PC requires a connection to a serial interface and the "ProfiSoft" software.

The current version of the software is available for download on our website

<http://www.krohne.com/html/dlc/index.shtml>.

You can find configuration instructions in the "ProfiSoft" reference manual.

### 5.2.1 *Smart Sense*

If the appropriate measuring sensors are provided (an additional wire in the sensor), the transmitter can continuously monitor the insulation resistance of the sensor, including the connection wires. This function (Smart Sense) is possible for resistance thermometers and thermocouples. If the insulation resistance is too low, the measured result will be incorrect and a message will be generated via ProfiBus.

This function requires configuration with the "ProfiSoft" software via a PC or via the ProfiBus.

### 5.2.2 *Monitoring of sensor aging*

If a resistance thermometer or a thermocouple with two sensors is used, the TT 60 can be used to monitor the aging of the sensor. The transmitter compares the measured values of the two sensors. Aging is indicated if the differential between the measured values is too great. In this case a message is generated via the ProfiBus. For further information, see the "Profisoft" manual.



#### **Action**

To protect the PC connections, they must be closed off using the supplied protection caps after configuration has been completed.

## 6.1 TT 60 C specifications

### 6.1.1 Technical data

	Designation	Value
<b>Input</b>	Pt10, Pt50, Pt100, Pt200, Pt500, Pt1000	-200...+850°C
	Ni50, Ni100, Ni120, Ni1000	-200... +250°C
	Potentiometer	0...4000 Ω
	Thermocouples	Types: B, C, D, E, G, J, K, L, N, R, S, T, U
	Voltage	-10...+1000 mV
<b>Redundant channels and arithmetic functions</b>	Differential	channel 1 - channel 2 or channel 2 - channel 1
	Average value	0.5 x (channel 1 + channel 2)
	Average value with redundancy	0.5 x (channel 1 + channel 2), channel 1 or channel 2 if the other channel fails
	Minimum value	Min (channel 1, channel 2)
	Maximum value	Max (channel 1, channel 2)
<b>Sensor break function</b>		On / Off
<b>Output</b>	Profibus-PA®	
<b>Ambient temperature</b>		-40...+85°C
<b>Galvanic isolation</b>		1500 VAC, 1 min
<b>Power supply</b>		9...32 VDC
<b>Power consumption</b>		11 mA
<b>Typical accuracy</b>	Pt100	0.1°C
<b>Connection head</b>		DIN B or larger

Table 2: TT 60 C specifications

## 6.1.2 TT 60 C dimensions

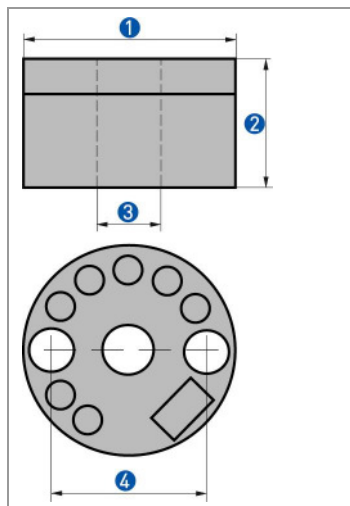

Figure 11: TT 60 C dimensions

	Dimension [mm]	Dimension [inch]
1	44	1.73
2	27	1.06
3	7	0.28
4	33	1.30

## 6.1.3 Data inputs and outputs

Bus connection (terminals 6+7)		Sensor connection (terminals 1-5)		Communications connection	
$U_i = V_{max}$	30 VDC	$U_0 = Voc$	30 VDC	$U_i = V_{max}$	8.0 VDC
$I_i = I_{max}$	not limited	$I_0 = Isc$	0.4 mA	$I_i = I_{max}$	450 mA
$P_i = P_{max}$	not limited	$P_0 = Pt$	6.5 mW	$P_i = P_{max}$	800 mW
$C_i$	1 nF	$C_0 = Ca$	1000 nF	$C_i$	10 nF
$L_i$	10 $\mu$ H	$L_0 = La$	750 mH	$L_i$	1 $\mu$ H

Table 3: TT 60 C input/output electrical data

## 6.1.4 Ambient temperature data for areas with potentially explosive atmospheres, TT 60 C

Temperature class	Ambient temperature
T6	$-40^{\circ}\text{C} \leq Ta \leq +75^{\circ}\text{C}$
T5	$-40^{\circ}\text{C} \leq Ta \leq +85^{\circ}\text{C}$
T4	$-40^{\circ}\text{C} \leq Ta \leq +85^{\circ}\text{C}$

Tabelle 4: Temperature data, TT 60 C

## 6.2 TT 60 C<sup>Ex</sup> specifications

### 6.2.1 Technical data

	Designation	Value
<b>Input</b>	Pt10, Pt50, Pt100, Pt200, Pt500, Pt1000	-200...+850°C
	Ni50, Ni100, Ni120, Ni1000	-200...+250°C
	Potentiometer	0...4000 Ω
	Thermocouples	Types: B, C, D, E, G, J, K, L, N, R, S, T, U
	Voltage	-10...+1000 mV
<b>Redundant channels and arithmetic functions</b>	Differential	channel 1 - channel 2 or channel 2 - channel 1
	Average value	0.5 x (channel 1 + channel 2)
	Average value with redundancy	0.5 x (channel 1 + channel 2), channel 1 or channel 2 if the other channel fails
	Minimum value	Min (channel 1, channel 2)
	Maximum value	Max (channel 1, channel 2)
<b>Sensor break function</b>		On / Off
<b>Output</b>	Profibus-PA®	
<b>Ambient temperature</b>		-40...+85°C
<b>Galvanic isolation</b>		1500 VAC, 1 min
<b>Power supply</b>		9...17.5 VDC
<b>Power consumption</b>		11 mA
<b>Typical accuracy</b>	Pt100	0.1°C
<b>Connection head</b>		DIN B or larger

Table 5: TT 60 C<sup>Ex</sup> specifications

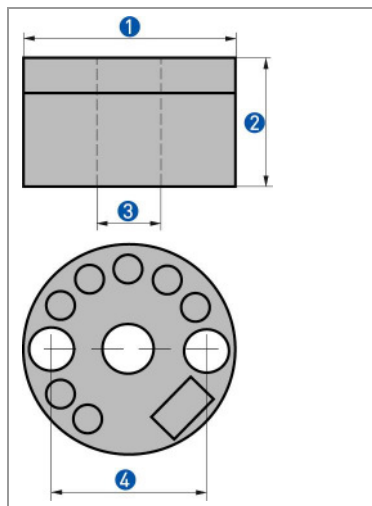

6.2.2 TT 60 C  $\text{Ex}$  dimensionsFigure 12: TT 60 C  $\text{Ex}$  dimensions

	Dimension [mm]	Dimension [inch]
1	44	1.73
2	27	1.06
3	7	0.28
4	33	1.06

## 6.2.3 Data inputs and outputs

Bus connection (terminals 6+7)		Sensor connection (terminals 1-5)		Communications connection	
$U_i = V_{\max}$	17.5 VDC	$U_0 = V_{oc}$	17.5 VDC	$U_i = V_{\max}$	8.0 VDC
$I_i = I_{\max}$	380 mA	$I_0 = I_{sc}$	56 mA	$I_i = I_{\max}$	450 mA
$P_i = P_{\max}$	5.32 W	$P_0 = P_t$	244 mW	$P_i = P_{\max}$	800 mW
$C_i$	1 nF	$C_0 = C_a$	166 nF	$C_i$	10 nF
$L_i$	10 $\mu$ H	$L_0 = L_a$	6 mH	$L_i$	1 $\mu$ H

Table 6: TT 60 C  $\text{Ex}$  input/output electrical data6.2.4 Ambient temperature data for areas with potentially explosive atmospheres, TT 60 C  $\text{Ex}$ 

Temperature class	Ambient temperature
T6	$-40^{\circ}\text{C} \leq T_a \leq +45^{\circ}\text{C}$
T5	$-40^{\circ}\text{C} \leq T_a \leq +60^{\circ}\text{C}$
T4	$-40^{\circ}\text{C} \leq T_a \leq +85^{\circ}\text{C}$

Table 7: TT 60 C  $\text{Ex}$  temperature data

## 6.3 TT 60 R specifications

### 6.3.1 Technical data

	Designation	Value
<b>Input</b>	Pt10, Pt50, Pt100, Pt200, Pt500, Pt1000	-200...+850°C
	Ni50, Ni100, Ni120, Ni1000	-200...+250°C
	Potentiometer	0...4000 Ω
	Thermocouples	Types: B, C, D, E, G, J, K, L, N, R, S, T, U
	Voltage	-10...+1000 mV
<b>Redundant channels and arithmetic functions</b>	Differential	channel 1 - channel 2 or channel 2 - channel 1
	Average value	0.5 x (channel 1 + channel 2)
	Average value with redundancy	0.5 x (channel 1 + channel 2), channel 1 or channel 2 if the other channel fails
	Minimum value	Min (channel 1, channel 2)
	Maximum value	Max (channel 1, channel 2)
<b>Sensor break function</b>		On / Off
<b>Output</b>	Profibus-PA®	
<b>Ambient temperature</b>		-20.. +70°C
<b>Galvanic isolation</b>		1500 VAC, 1 min
<b>Power supply</b>		9...32 VDC
<b>Power consumption</b>		11 mA
<b>Typical accuracy</b>	Pt100	0.1°C
<b>Installation</b>		Rail according to EN 50020, 35 mm

Table 8: TT 60 R specifications

## 6.3.2 TT 60 R dimensions

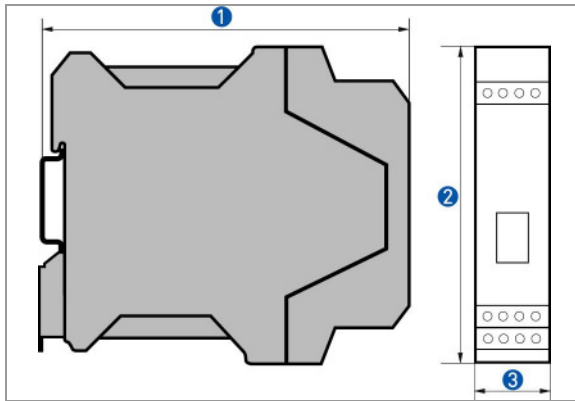



Figure 13: TT 60 R dimensions

	Dimension [mm]	Dimension [inch]
1	115	4.53
2	100	3.93
3	22.5	0.88

## 7.1 Ordering information

Product	Order No.
TT 60 C	VIP04H000010000
TT 60 C  ATEX	VIP04HX00010000
TT 60 R	VIP04L000010000
<b>Software and cables</b>	
PC configuration set	VI70CFG00092
ATEX cable for PC connection (contained in the configuration set VI70CFG00092)	VI70IPRX0002
Adapter cable (4-pole) (contained in the configuration set VI70CFG00092)	VI70IPRP0001
<b>Accessories</b>	
Field housing for floor installation	VI70ADA00008
Field housing for DIN rail installation	VI70ADA00009
Connection head installation kit	VI70ADA00017
Rail installation clip	VI70ADA00013
Display LCD-W12	VI70LCDW1201
Configuration ex works	VI70CAL00001

For your notes:

For your notes:

For your notes:

## KROHNE Product Overview

- Electromagnetic flowmeters
- Variable area flowmeters
- Mass flowmeters
- Ultrasonic flowmeters
- Vortex flowmeters
- Flow controllers
- Level measuring instruments
- Pressure gauges
- Temperature measuring instruments
- Water solutions & analysis
- Oil and gas turnkey solutions

### Addresses:

#### Germany

##### Northern sales office

KROHNE Messtechnik GmbH & Co. KG  
Bremer Str. 133  
D-21073 Hamburg  
Phone: +49 (0)40 767 3340  
Fax: +49 (0)40 767 33412  
nord@krohne.de  
ZIP code: 10000 - 29999, 49000 - 49999

##### Western and middle sales office

KROHNE Messtechnik GmbH & Co. KG  
Ludwig-Krohne-Straße  
D-47058 Duisburg  
Phone: +49 (0)203 301 416  
Fax: +49 (0)203 301 10416  
west@krohne.de  
ZIP code: 30000 - 34999, 37000 - 48000, 50000 - 53999, 57000 - 59999, 98000 - 99999

##### Southern sales office

KROHNE Messtechnik GmbH & Co. KG  
Landsberger Str. 392  
D-81241 Munich  
Phone: +49 (0)89 121 5620  
Fax: +49 (0)89 129 6190  
sued@krohne.de  
ZIP code: 0 - 9999, 80000 - 89999, 90000 - 97999

##### Southwestern sales office

KROHNE Messtechnik GmbH & Co. KG  
Rüdesheimer Str. 40  
D-65239 Hochheim/Main  
Phone: +49(0)6146) 827 30  
Fax: +49 (0)6146 827 312  
rhein-main@krohne.de  
ZIP code: 35000 - 36999, 54000 - 56999, 60000 - 79999

##### Instrumentation and control equipment catalog

TABLAR Messtechnik GmbH  
Ludwig-Krohne-Straße 5  
D-47058 Duisburg  
Phone: +49 (0)2 03 305 880  
Fax: +49 (0)2 03 305 8888  
kontakt@tablar.de www.tablar.de

#### KROHNE sales companies

##### International

##### Australia

KROHNE Australia Pty Ltd  
Quantum Business Park 10/287  
Victoria Rd Rydalmere NSW 2116  
Phone: +61 2 8846 1700  
Fax: +61 2 8846 1755  
krohne@krohne.com.au

##### Austria

KROHNE Austria Ges.m.b.H.  
Modencenterstraße 14  
A-1030 Vienna  
Phone: +43 (0)1/203 45 32  
Fax: +43 (0)1/203 47 78  
info@krohne.at

##### Belgium

KROHNE Belgium N.V.  
Brusselstraat 320  
B-1702 Groot Bijgaarden  
Phone: +32 (0)2 4 66 00 10  
Fax: +32 (0)2 4 66 08 00  
krohne@krohne.be

##### Brazil

KROHNE Conaut Controles  
Automaticos Ltda.  
Estrada Das Águas Espraíadas, 230  
C.P. 56 06835 - 080 EMBU - SP  
Phone: +55 (0)11-4785-2700  
Fax: +55 (0)11 4785-2768  
conaut@conaut.com.br

##### China

KROHNE Measurement Instruments  
(Shanghai) Co. Ltd., (KMIC)  
Room 1501  
1033 Zhaoyabang Road  
Shanghai 200030  
Phone: +86 21 6487 9611  
Fax: +86 21 6438 7110  
info@krohne-asia.com

##### Czech Republic

Soběsická 156  
63800 Brno  
Phone: +420 (0)545.242 627  
Fax: +420 (0)545 220 093  
brno@krohne.cz

##### France

KROHNE S.A.S.  
Les Ors BP 98  
F-26103 ROMANS Cedex  
Phone: +33 (0)4 75 05 44 00  
Fax: +33 (0)4 75 05 00 48  
info@krohne.fr

##### Great Britain

KROHNE Ltd.  
Rutherford Drive  
Park Farm Industrial Estate  
Wellingborough  
Northants NN8 6AE  
Phone: +44 (0)19 33 408 500  
Fax: +44 (0)19 33 408 501  
info@krohne.co.uk

##### CIS

Kanex KROHNE Engineering AG  
Business-Centre Planeta  
Office 404 ul.  
Marxistskaja 3  
109147 Moscow/Russia  
Phone: +7 (0)095 911 7165  
Fax: +7 (0)095 742 8873  
krohne@do.ru

##### India

Krohne Marshall Ltd.  
A-34/35, M.I.D.C. Industrial Area,  
H-Block  
Pimpri Poona 411018  
Phone: +91 (0)202 744 2020  
Fax: +91 (0)202 744 2020  
pcu@vsnl.net

##### Iran

KROHNE Liaison Office  
North Sohrevardi Ave. 26,  
Sarmad St. Apt. #9  
Tehran 15539  
Phone: +9821 8874 5973  
Fax: +9821 8850 1268  
krohne@krohneiran.com

##### Italy

KROHNE Italia Srl.  
Via V. Monti 75  
I-20145 Milan  
Phone: +39 02 4300 661  
Fax: +39 02 4300 6666  
info@krohne.it

##### Korea

KROHNE Korea  
Room 508 Miwon Bldg 43  
Yoido-Dong Youngdeungpo-Ku  
Seoul, Korea  
Phone: 00-82-2-782-1900  
Fax: 00-82-2-780-1749  
krohnekorea@krohnekorea.com

##### Netherlands

KROHNE Nederland B.V.  
Kerkeplaat 14  
NL-3313 LC Dordrecht  
Phone: +31 (0)78 630 6200  
Fax: +31 (0)78 630 6405  
Service Direct: +31 (0)78 630 6222  
info@krohne.nl

##### Norway

KROHNE Norway A.S.  
Ekholtsveien 114  
NO-1521 Moss  
Phone: +47 (0)169 264 860  
Fax: +47 (0)169 267 333  
postmaster@krohne.no

##### Poland

KROHNE Polska Sp.z o.o.  
ul. Stary Rynek Oliwski 8a  
80-324 Gdansk  
Phone: +48 (0)58 520 9211  
Fax: +48 (0)58 520 9212  
info@krohne.pl

##### Switzerland

KROHNE AG  
Uferstr. 90  
CH-4019 Basel  
Phone: +41 (0)61 638 30 30  
Fax: +41 (0)61 638 30 40  
info@krohne.ch

##### Singapore

Tokyo Keiso - KROHNE (Singapore)  
Pte. Ltd.  
14, International Business Park,  
Jurong East  
Chiyoda Building, #01-01/02  
Singapore 609922  
Phone: (65) 6567 4548  
Fax: (65) 6567 9874  
tks@tokyokeiso-krohne.com.sg

##### Republic of South Africa

KROHNE Pty. Ltd.  
Bushbuck Close  
Corporate Park South  
Midrand, Gauteng  
P.O. Box 2049  
Midrand, 1685  
Phone: +27 (0)11 314 1391  
Fax: +27 (0)11 314 1681  
midrand@krohne.co.za

##### Spain

I.J. KROHNE IBERIA, S.r.L.  
Polígono Industrial Nilo  
Calle Brasil, nº. 5  
28806 Alcalá de Henares Madrid  
Phone: +34 (0)91 883 2152  
Fax: +34 (0)91 883 4854  
krohne@krohne.es

##### USA

KROHNE, Inc.  
7 Dearborn Road  
Peabody, MA 01960  
Phone: +1 (800) FLOWN6  
Phone: +1 (978) 535 6060 (in MA)  
info@krohne.com

#### Representatives

Algeria  
Argentina  
Cameroon  
Canada  
Chile  
Columbia  
Croatia  
Denmark  
Ecuador  
Egypt  
Finland  
Gabon  
Ghana  
Greece  
Hong Kong  
Hungary  
Indonesia  
Iran  
Ireland  
Israel  
Ivory Coast  
Japan  
Jordan  
Kuwait  
Libya  
Lithuania  
Malaysia  
Mauritius  
Mexico  
Morocco  
New Zealand  
Peru  
Portugal  
Romania  
Saudi Arabia  
Senegal  
Slovakia  
Slovenia  
Sweden  
Taiwan  
Thailand  
Tunisia  
Turkey  
Venezuela  
Yugoslavia

#### Other countries

KROHNE Messtechnik GmbH & Co. KG  
Ludwig-Krohne-Str. 5  
D-47058 Duisburg  
Phone: +49 (0)203 301 0  
Fax: +49 (0)203 301 389  
export@krohne.de

