



# MultiLoad II Skid Control System



## Installation Guide

Part # 4803  
January 12, 2016

### EC Declaration Of Conformity

The signatory, representing the manufacturer, declares that the products listed below are in conformity with the essential requirements of the following EC Directive(s) when installed in accordance with the product installation instructions:

2004/22/EC	The Measuring Instruments Directive (and its amending directives)
2004/108/EC	The Electromagnetic Compatibility Directive (and its amending directives)
94/9/EEC	The Potentially Explosive Atmospheres Directive (and its amending directives)
<b>Product:</b>	Process Controller with Operator Interface intended for use in potentially explosive atmospheres
<b>Model name/number:</b>	MultiLoad II SCS
<b>Protective Systems:</b>	Flameproof 'd', Intrinsic Safety 'ib'

<b>Notified Body(ies)</b>	Demko A/S Testing and Certification,	NMi Certin B.V., Number 0122
	Number 0539	Hugo de Grootplein 1
	P.O. Box 514, Lyskaer 8	3314 EG Dordrecht
	DK-2730 Herlev, Denmark	The Netherlands

#### Conformity has been demonstrated with reference to the following documentation:

EC type-examination certificate 06 ATEX 0619833X  
EC type-examination certificate TC7311

#### Compliance with the Essential Health and Safety Requirements has been assessed by reference to the following standards:

WELMEC guide 8.8	General and Administrative Aspects of the Voluntary System of Modular Evaluation of Measuring instruments under MID
OIML R117-1:2007(E)	Dynamic measuring systems for liquids other than water
EN 61000-6-4: 2007	Generic emissions for industrial operating environments
EN 61000-6-2: 2005	Generic immunity for industrial operating environments
EN 60079-0: 2009	Electrical apparatus for explosive gas atmospheres—General requirements
EN 60079-1: 2007	Electrical apparatus for explosive gas atmospheres— Flameproof enclosures 'd'
EN 60079-11: 2007	Electrical apparatus for potentially explosive atmospheres—Intrinsic safety 'i'

Year of CE Marking: 2006

Name: William J. Porthouse

Position: Director of Engineering & Production

Date: 31-Oct-2012

 <b>Totech Systems, Inc.</b> LIQUID CONTROLS GROUP	1124 Florida Central Pkwy Longwood, FL 32750 USA	 CONFORMS TO UL STD 916, UL STD 120A, UL STD 80 & 80B, UL STD 916/1-4, CERTIFIED TO CSA STD C22.2 NO. 197-02, CSA STD C22.2 NO. 28-98, CSA STD C22.2 NO. 84-1 & 84-2, CSA STD C22.2 NO. 910-1, CONFORMS TO IEC STD 60629
	MODEL: MULTILOAD II SMP INPUT POWER: <input type="checkbox"/> 18-36Vdc, CLASS 2 (SELV, LIMITED ENERGY), 600mA <input type="checkbox"/> 85-250Vac, 47-63Hz, 300mA-160mA PART NO. 4809	
DIGITAL OUTPUTS (PER POINT): AC 12-250Vac, 47-63Hz, 0.5A DC 0-30Vdc, 0.8A		<b>CE 0575</b>  <b>II 2G</b> Ex d ib IIB T4 (-40°C ≤ Ta ≤ +60°C) Gb IP65 DEMKO 06 ATEX 0619833X
TYPE 4, IP65 -40°C ≤ Tamb ≤ +60°C CLASS I, DIV. 1 GROUPS C & D, T4		MAX. METER INPUT FREQUENCY: 5kHz PRESSURE INPUT RANGE: 0 - 4000 KPa RTD INPUT: 100Ω α = 0.00385 ANALOG INPUT: 4mA - 20mA
MFG DATE <input type="text"/> SERIAL NO. <input type="text"/>	APPROVALS: NTEP C of C 07-010 AV-2397C AV-2398 TC7311	
<p>  <b>WARNING: TO REDUCE THE RISK OF IGNITION OF HAZARDOUS ATMOSPHERES, CONDUIT RUNS MUST HAVE A SEALING FITTING CONNECTED WITHIN 18 INCHES OF THE ENCLOSURE.</b> </p> <p>  <b>WARNING: TO REDUCE THE RISK OF IGNITION OF HAZARDOUS ATMOSPHERES, DISCONNECT FROM THE SUPPLY CIRCUIT BEFORE OPENING ENCLOSURE. KEEP TIGHTLY CLOSED WHEN CIRCUITS ARE LIVE.</b> </p> <p>  <b>WARNING: DO NOT OPEN WHEN AN EXPLOSIVE GAS ATMOSPHERE IS PRESENT.</b> </p> <p>  <b>WARNING: SUBSTITUTION OF COMPONENTS MAY IMPAIR INTRINSIC SAFETY.</b> </p> <p>  <b>WARNING: CONSULT INSTALLATION MANUAL FOR REQUIRED CABLE ENTRY SIZE &amp; THREAD.</b> </p> <p>  <b>AVERTISSEMENT: RISQUE D'EXPLOSION. LES SCHELEMENTS DES CONDUITS DOIT ÊTRE INSTALLÉ À MOINS DE 18 POUCES DU BOÎTIER.</b> </p> <p>  <b>AVERTISSEMENT: RISQUE D'EXPLOSION. COUPER LE COURANT AVANT D'ENLEVER LE COUVERCLE.</b> </p> <p>  <b>AVERTISSEMENT: LA SUBSTITUTION DE COMPOSANTS PEUT COMPROMETTRE LA SÉCURITÉ INTRINSÈQUE.</b> </p> <p>  <b>AVERTISSEMENT: NE PAS OUVRIR SI UNE ATMOSPHÈRE EXPLOSIVE PEUT ÊTRE PRÉSENTE.</b> </p> <p>  <b>CONSULTEZ LE MANUEL D'INSTALLATION POUR LE FILETAGE ET LA TAILLE DES PRESSE-ÉTOUPES.</b> </p>		

## **SAFETY WARNINGS (AVERTISSEMENTS DE SÉCURITÉ)**



### **NORTH AMERICAN INSTALLATIONS:**

- ▲ This equipment is suitable for use in Class I, Division 1, Groups C and D locations or non-hazardous locations only.
- ▲ **WARNING: TO REDUCE THE RISK OF IGNITION OF HAZARDOUS ATMOSPHERES, conduit runs must have a sealing fitting connected within 18 inches of the enclosure.**
- ▲ **WARNING: TO REDUCE THE RISK OF IGNITION OF HAZARDOUS ATMOSPHERES, disconnect from the supply circuit before opening enclosure. Keep tightly closed when circuits are live.**
- ▲ **WARNING: Substitution of components may impair intrinsic safety.**
- ▲ **WARNING: Do not open when an explosive gas atmosphere is present.**
- ▲ **WARNING: All unused conduit entries must be sealed with a conduit plug which satisfies the flameproof “d” method of protection.**
- ▲ **CAUTION: Battery may explode if mistreated. DO NOT RECHARGE, DISASSEMBLE, OR DISPOSE OF IN FIRE.**
- ▲ **CAUTION: Field wiring must have a temperature rating of +75 °C or greater.**
- ▲ **Consult installation manual for required cable entry size and thread.**
- ▲ A battery is soldered to the processor board for retention of data, time, and date. This battery should last more than ten years. Please return the board to Toptech Systems for battery replacement. This battery must be replaced with Matsushita Electric, model BR2477A only. Use of another battery may present a risk of fire or explosion.
- ▲ The installation of this product must be in conformity with NFPA 70 (US National Electric Code) or CSA C22.1 (Canadian Electrical Code) as appropriate.



### **INSTALLATIONS NORD-AMÉRICAINES (FRANÇAIS)**

- ▲ Cet équipement est compatible pour une installation en Classe I, Division 1, Groupes C & D ou les emplacements non dangereux.
- ▲ **AVERTISSEMENT: RISQUE D'EXPLOSION Les scellements des conduits doit être installé à moins de 18 pouces du boîtier.**
- ▲ **AVERTISSEMENT: RISQUE D'EXPLOSION Couper le courant avant d'enlever le couvercle. Garder le couvercle bien fermé tant que les circuits sont sous tension.**
- ▲ **AVERTISSEMENT: La substitution de composants peut compromettre la sécurité intrinsèque.**
- ▲ **AVERTISSEMENT: Ne pas ouvrir si une atmosphère explosive peut être présente.**
- ▲ **AVERTISSEMENT: Toutes les entrées du boîtier inutilisées doivent être scellées avec un bouchon de conduit.**
- ▲ **PRUDENCE: La pile peut exploser si elle est maltraitée. NE PAS RECHARGER, NE PAS DÉMONTER, ET NE PAS JETER DANS LE FEU.**
- ▲ **PRUDENCE: Câblage de terrain doit avoir un classement de température de +75 °C ou plus.**
- ▲ **Consultez le manuel d'installation pour le filetage de forme et la taille du presse-étoupe.**
- ▲ Une pile est soudée à la carte processeur pour la conservation des données, de l'heure, et de la date. Cette pile devrait durer pendant plus que dix ans. Veuillez retourner la carte processeur à Toptech Systems pour le remplacement de la pile. **Remplacez la pile avec Matsushita Electric, modèle BR2477A seulement. Utiliser une autre pile peut présenter un risque d'incendie ou d'explosion.**
- ▲ L'installation de ce produit doit se conformer avec NFPA 70 ou CSA C22.1 comme appropriée.



## **ATEX AND IECEx INSTALLATIONS:**

- ▲ This equipment is suitable for use in Ex Zone I Group IIB locations or non-hazardous locations.
- THE LETTER “X” TO THE RIGHT OF THE CERTIFICATE NUMBER INDICATES THE FOLLOWING SPECIAL CONDITIONS FOR SAFE USE:**
- ▲ **CERTAIN FLAMEPROOF JOINTS ARE OTHER THAN THE MINIMUM OR MAXIMUM DIMENSIONS GIVEN IN IEC/EN/BR 60079-1, CLAUSE 5. PLEASE CONSULT TOPTECH SYSTEMS IF DIMENSIONAL INFORMATION IS REQUIRED.**
  - ▲ **MAXIMUM SPECIFIED GAP OF FLANGE JOINT IS 0.08mm.**
  - ▲ **AMBIENT TEMPERATURE RANGE IS BETWEEN -40°C AND +60°C.**
  - ▲ **CAUTION: COVER BOLTS MUST HAVE A YIELD STRESS OF AT LEAST 450 N/mm<sup>2</sup>.**
  - ▲ **WARNING: TO REDUCE THE RISK OF IGNITION OF HAZARDOUS ATMOSPHERES, disconnect from the supply circuit before opening enclosure. Keep tightly closed when circuits are live.**
  - ▲ **WARNING: Substitution of components may impair intrinsic safety.**
  - ▲ **WARNING: Do not open when an explosive gas atmosphere is present.**
  - ▲ **WARNING: All unused conduit entries must be sealed with a conduit plug which satisfies the flameproof “d” method of protection. Blanking elements must be removable with the aid of a tool, ATEX certified, suitable for Gas Group IIB and suitable for an ambient temperature range of -40 C to +60 C.**
  - ▲ **CAUTION: Battery may explode if mistreated. DO NOT RECHARGE, DISASSEMBLE, OR DISPOSE OF IN FIRE.**
  - ▲ **CAUTION: Field wiring must have a temperature rating of +75 °C or greater. It must also have a temperature rating for the lowest expected minimum ambient temperature.**
  - ▲ **Consult installation manual for required cable entry size and thread.**
  - ▲ A battery is soldered to the processor board for retention of data, time, and date. This battery should last more than ten years. Please return the board to Toptech Systems for battery replacement. This battery must be replaced with Matsushita Electric, model BR2477A only. Use of another battery may present a risk of fire or explosion.
  - ▲ The installation of this product must be in conformity with IEC/EN 60079-14.

---

### Copyright Notice

Copyright © 2006 - 2016 Toptech Systems, Inc.

The information contained in this document is proprietary and confidential. No part of this document may be copied, reproduced, or transmitted in any medium without the express written permission of Toptech Systems, Inc.

---

### Disclaimer

Toptech Systems assumes no responsibility for damages resulting from installation or use of its products. Toptech Systems will not be liable for any claims of damage, lost data, or lost time as a result of using its products.

---



#### **MULTILOAD II**

Integrated Flow Controller



#### **MULTILOAD II SCS**

Skid Control System



#### **MULTILOAD II SMP**

Single Meter Preset



#### **RCU II**

Remote Control Unit



#### **TMS6**

Terminal Management System



#### **UAP**

Unified Automation Platform



#### **BPA**

Bulk Plant Automation

Logos are registered trademarks of Toptech Systems, Inc.

**Copyright © 2007-2016 Toptech Systems, Inc. All Rights Reserved.**

# Table of Contents

Safety Warnings (Avertissements de Sécurité) .....	3
<b>CHAPTER 1 General</b> .....	<b>10</b>
1.1 Who Should Use This Guide .....	10
1.2 Information Alerts:.....	10
1.2.1 Typographical Conventions: .....	10
1.2.2 Receiving and/or Returning Equipment: .....	10
1.3 Operating Characteristics: .....	11
1.4 Electrostatic Discharge (ESD) Protection:.....	12
1.5 FCC Note: .....	12
<b>CHAPTER 2 Installing The MultiLoad II SCS</b> .....	<b>13</b>
2.1 Tools Required.....	13
2.1.1 Installation.....	13
2.1.2 Servicing and Repair .....	13
2.2 Cover Closure and Bolt Replacement .....	13
2.3 Mounting The MultiLoad II SCS Enclosure: .....	13
2.3.1 Metal Plate or Rail .....	13
2.3.2 Wood.....	13
2.3.3 Concrete, Solid Block, or Brick Walls .....	14
2.3.4 Mounting Height Considerations .....	14
2.4 Recommended Wire Sizes And Torque For All Terminal Blocks .....	15
2.5 Electrical Supply Connections.....	16
2.5.1 Cable Gland Entries.....	16
2.5.2 AC Powered Models.....	17
2.5.3 DC Powered Models.....	19
2.5.4 Equipment Grounding.....	19
<b>CHAPTER 3 Data Communications Interface</b> .....	<b>20</b>
3.1 Communications Protocol Selection and Connection: .....	21
3.1.1 RS-422/485:.....	21
3.1.2 RS-232.....	21
3.1.3 FCM I / FCM II / PCM Communications (COM 0 - RS-485).....	22
3.1.4 Host/TMS Communications (COM 1 - RS-485 4-wire).....	23
3.1.5 Host/TMS Communications (COM 1 - RS-485 2-wire).....	24
3.1.6 Host/TMS Communications (COM 1 - RS-232).....	25
3.1.7 Host Ticket Printer/Data Logger (COM 2 - RS-232).....	26
3.1.8 Ethernet .....	27
<b>CHAPTER 4 I/O Configuration</b> .....	<b>28</b>
4.1 Connecting Field Devices to the I/O Board.....	28
4.1.1 MultiLoad II Flow Meter and Control Valve Wiring .....	30
4.1.2 MultiLoad II Sampler Wiring.....	31
4.1.3 MultiLoad II RTD Temperature Probe Wiring .....	32
4.1.4 MultiLoad II 4-20mA Input Wiring: Loop Current Provided by External Power Supply .....	33
4.1.5 MultiLoad II 4-20mA Input Wiring: Loop Current Provided by Transmitter.....	34
4.1.6 MultiLoad II 1-5 V Input Wiring: Single Wire Output.....	35
4.1.7 MultiLoad II 1-5 V Input Wiring: Two Wire Output .....	36
4.1.8 MultiLoad II AC Output Wiring .....	37
4.1.9 MultiLoad II AC Input / 3 Output Air Eliminator Wiring .....	38
4.1.10 MultiLoad II DC Input Wiring.....	39
4.1.11 MultiLoad II DC Output Wiring.....	40
<b>CHAPTER 5 Configuration</b> .....	<b>41</b>

<b>5.1</b>	<b>Switch Access Control.....</b>	<b>41</b>
5.1.1	<i>External Switch Access Control.....</i>	41
5.1.2	<i>External Type 1 Program / W&amp;M switches.....</i>	42
5.1.3	<i>External Type 2 Program / W&amp;M switches.....</i>	42
5.1.4	<i>External Type 3 Program / W&amp;M switches.....</i>	43
5.1.5	<i>Internal Switch Access Control.....</i>	44
5.1.6	<i>Field Switch Access Control.....</i>	44
<b>5.2</b>	<b>MultiLoad II/ RCU II EXL Keypad.....</b>	<b>44</b>
<b>5.3</b>	<b>Menus and Screens.....</b>	<b>45</b>
<b>5.4</b>	<b>Field Modification and Data Entry.....</b>	<b>46</b>
<b>5.5</b>	<b>MultiLoad II Preliminary Configuration:.....</b>	<b>48</b>
<b>5.6</b>	<b>Verify Communications Between MultiLoad II And I/O Board:.....</b>	<b>50</b>
<b>5.7</b>	<b>Using I/O Diagnostics.....</b>	<b>51</b>
<b>CHAPTER 6</b>	<b>Service and Repair.....</b>	<b>52</b>
<b>6.1</b>	<b>Modular Design:.....</b>	<b>52</b>
6.1.1	<i>Operating the Flat Display Cable Connectors:.....</i>	52
6.1.2	<i>CPU Subassembly Removal and Replacement:.....</i>	54
6.1.3	<i>Display Subassembly Removal and Replacement:.....</i>	54
6.1.4	<i>Keypad Removal and Replacement:.....</i>	55
6.1.5	<i>Keypad Barrier Circuit Removal and Replacement:.....</i>	55
<b>CHAPTER 7</b>	<b>Drawings and Part Numbers.....</b>	<b>56</b>
<b>CHAPTER 8</b>	<b>Manual Revision History.....</b>	<b>64</b>

## Table of Figures

Figure 2.1	Suggested Mounting Position and Screen Visible Area .....	14
Figure 2.2	MultiLoad II Terminal Block Recommended Wire Size and Screw Torque.....	15
Figure 2.3	MultiLoad II AC Power Supply/Comm Board.....	17
Figure 2.4	AC Supply Terminal Block Access .....	18
Figure 2.5	Removal of AC Wiring Side Partition .....	18
Figure 2.6	Replacement of AC Wiring Side Partition.....	18
Figure 2.7	DC Power Connections .....	19
Figure 2.8	Canadian I.S. Ground Connection.....	19
Figure 3.1	FCM / PCM Connections .....	22
Figure 3.2	RS485 4-Wire, Host to a Single MultiLoad II (recommended) .....	23
Figure 3.3	RS485 4-Wire, Host to Multiple MultiLoad IIs .....	23
Figure 3.4	RS485 2-Wire, Host to a Single MultiLoad II .....	24
Figure 3.5	RS485 4-Wire, Host to Multiple MultiLoad IIs .....	24
Figure 3.6	RS232, Host to a Single MultiLoad II .....	25
Figure 3.7	RS232, Host to Multiple MultiLoad IIs .....	25
Figure 3.8	Ticket Printer / Data Logger Connections with Handshake.....	26
Figure 3.9	Ticket Printer / Data Logger Connections without Handshake.....	26
Figure 3.10	Ethernet Connections .....	27
Figure 4.1	SCS I/O Board Terminal Block Assignments .....	29
Figure 4.2	SCS I/O Board Field Wiring: Flow Meter and Control Valve .....	30
Figure 4.3	SCS I/O Board Field Wiring: Sampler Valves .....	31
Figure 4.4	SCS I/O Board Field Wiring: RTD .....	32
Figure 4.5	SCS I/O Board Field Wiring: 4-20mA Input .....	33
Figure 4.6	SCS I/O Board Field Wiring: 4-20mA Input .....	34
Figure 4.7	SCS I/O Board Field Wiring: 1-5 V Input .....	35
Figure 4.8	SCS I/O Board Field Wiring: 1-5 V Input .....	36
Figure 4.9	SCS I/O Board Field Wiring: AC Pump and Block Valve Control.....	37
Figure 4.9	SCS I/O Board Field Wiring: AC Input / Air Eliminator .....	38
Figure 4.10	SCS I/O Board Field Wiring: DC Input.....	39
Figure 4.11	SCS I/O Board Field Wiring: DC Output.....	40
Figure 5.1	Type 1 Program / W&M Switches.....	42
Figure 5.2	Type 2 Program / W&M Switches.....	42
Figure 5.3	Type 3 Program / W&M Switches.....	43
Figure 5.4	CPU DIP Switches for Program and W&M Access (rev 1.0).....	44
Figure 5.5	CPU DIP Switches for Program and W&M Access (rev 2.0).....	44
Figure 6.1	Cam lock in the Open (Up) position.....	52
Figure 6.2	Display Cable Insertion.....	53
Figure 6.3	Cam lock in the closed (down) position .....	53
Figure 7.1	Unit Outline Drawing – Front View .....	56
Figure 7.2	Unit Outline Drawing – Back View .....	57
Figure 7.3	Unit Outline Drawing – Bottom View .....	58
Figure 7.4	Unit Outline Drawing – Side View.....	59
Figure 7.5	MultiLoad II/ RCU II Div2 Unit Assembly Prox Slotted Card Holder Mount.....	60
Figure 7.6	Exploded View Front Cover Assembly: Prox Slotted Card Holder Mount.....	60
Figure 7.7	MultiLoad II/ RCU II Div2 Unit Assembly Prox Slotted Card Holder Mount: TWIC Reader.....	61



---




Figure 7.8	Exploded View Front Cover Assembly: Prox Slotted Card Holder Mount: TWIC Reader.....	61
Figure 7.9	Ice Shield Assembly On Slotted Card Holder Mount:.....	62
Figure 7.10	Power Supply / Comm Board & I/O Board Chassis.....	62

## CHAPTER 1 GENERAL

### 1.1 WHO SHOULD USE THIS GUIDE

This guide is intended for individuals installing MultiLoad II equipment, engineering firms developing site electrical drawings, and users troubleshooting system operation such as managers, system administrators, technicians, and meter proving personnel.

### 1.2 INFORMATION ALERTS:

	Important information to enhance understanding and make better use of the product.
	Indicates potential damage to hardware or loss of data.
	Potential for property damage or that personal injury may occur. Pay close attention and follow instructions when you see this symbol.

#### 1.2.1 TYPOGRAPHICAL CONVENTIONS:

**Boldface:** Indicates what you are to press on the keypad. Example: Key in **00000**.

*Italics:* Emphasizes a key product or industry term.  
Example: the display features a *pick list* style of item selection.

#### 1.2.2 RECEIVING AND/OR RETURNING EQUIPMENT:

The MultiLoad II should be immediately inspected after opening the packaging case. If any damage is visible notify the carrier at once to establish liability. Contact Toptech Account Management to initiate timely repair or replacement of the unit.

Account Management will issue a Return Materials Authorization (RMA) to return the product or parts requiring repair. Do not return any material to Toptech without an RMA.

Account Management contact information:

Account Management  
Toptech Systems  
1124 Florida Central Pkwy  
Longwood, FL  
(407) 332-1774

Prior to installation the MultiLoad II should be stored in its packing case and be protected from damage due to handling and adverse weather conditions.

### 1.3 **OPERATING CHARACTERISTICS:**

For product outline and dimensions see [Appendix Figures 7.1 to 7.3.](#)

Operating voltage: 85 - 250 Vac, 47-63 Hz, 300 – 150 mA OR

**Voltage Option:** 18 - 36 Vdc, 600mA

Operating temperature: -22°F to 140°F (-25°C to 60°C).

**with Optional Heater:** -40°F to 140°F (-40°C to 60°C).

Explosion proof enclosure:

Type 4, IP65

ETL Listed (US, Canada) Class 1, Division 1, Groups C & D

ATEX Certified Group IIB, T4, Category 2G: DEMKO 06 ATEX 0619833X

Weight: 22 lbs (10 kg)

Display: Color 4" Diagonal, QVGA

**Optional Lockable External Switches:** Program Access, Weights & Measures Parameter Access

Keypad: 18 Key Numeric Membrane Switch Keypad

Communications:

3 serial ports (1 RS-232, 1 RS-485, 1 User Selectable RS-232 or RS-485)

1 Ethernet port 10/100 MBPS

Internal I/O Board Type and Electrical Ratings:

TYPE I/O	QUANTITY, LOCATION	ELECTRICAL RATING
AC Outputs:	8 (TB2)	12 - 250 Vac rms, 500 mA (per point)
AC Inputs:	6 (TB1)	90 - 250 Vac rms, 500 mA (per point)
DC Outputs:	2 (TB7)	0 - 30 Vdc, 600 mA (per point)
DC Inputs:	6 (TB5) (4 High Speed)	5 - 30Vdc Dual Channel flow meter inputs (1-5000Hz)
12 Vdc Source:	(TB6)	3 W, 250 mA Max Load
RTD Input:	1 (TB3)	100-ohm platinum, four wire Coefficient 0.00385 Ohm/Ohm/°C
Analog Input: 4-20 mA	4 (2 TB3 and 2 TB4)	4 - 20mA, 1.5V maximum burden (2.3 V MAX VOLTAGE)
Analog Input: 1-5 V	1 (TB4)	1 – 5 V

#### **1.4 ELECTROSTATIC DISCHARGE (ESD) PROTECTION:**

The MultiLoad II contains electronic components and assemblies subject to damage by ESD. The MultiLoad II was designed to protect against ESD while the unit is closed and in normal operation. Proper handling procedures must be observed during the removal, installation, repair and other handling of printed circuit board assemblies, electronic devices and components to include:

- 1) Service to be performed by authorized personnel only.
- 2) The person performing the service must be grounded by an ESD grounding strap and connected to ground.
- 3) While performing maintenance or repair, touch an unpainted metal of the MultiLoad II surface prior to touching or handling any printed circuit boards or electronic components.
- 4) Printed circuit board assemblies must be placed in and transported in conductive bags or other conductive containers.
- 5) Printed circuit boards must not be removed from the conductive container until time of use.
- 6) All other "best" practices for protecting devices from ESD must be observed.

#### **1.5 FCC NOTE:**

This equipment complies with the limits for a Class A digital device, pursuant to part 15 of the FCC Rules. These limits are designed to provide reasonable protection against harmful interference when the equipment is operated in a commercial environment. This equipment generates, uses, and can radiate radio frequency energy and, if not installed and used in accordance with the instruction manual, may cause harmful interference to radio communications. Operation of this equipment in a residential area is likely to cause harmful interference in which case the user will be required to correct the interference at his own expense.

Modifications not expressly approved by the manufacturer could void the user's authority to operate the equipment under FCC rules.

## CHAPTER 2 INSTALLING THE MULTILOAD II SCS

### 2.1 TOOLS REQUIRED

#### 2.1.1 *INSTALLATION*



- 6 mm hex wrench required for tightening cover bolts

#### 2.1.2 *SERVICING AND REPAIR*

- #4 Philips screwdriver for circuit board removal
- ¼" socket wrench for CPU circuit board removal, 5/16" socket wrench for display board removal
- Torx T15 for removal of keypad bezel security screws

### 2.2 COVER CLOSURE AND BOLT REPLACEMENT

The enclosure cover is secured to the housing by twelve 8mm hex cap screws. A 6mm Allen head wrench is required to remove the screws. After the bolts are removed, the front cover will swing left and hang from its hinges. To close the cover, gently lift on the bottom right corner when in position and start one or two of the lower right corner bolts. This is done to assist in alignment of the cover and base holes for starting the bolts. Dry stainless steel fasteners can gall or seize in aluminum, so please be sure to use a petrolatum or similar lubricant.

	Be sure to keep the flanges clean and free of scratches and nicks so as not to compromise the quenching ability of the flame path
	All cover bolts must be tightened to maintain the explosion proof capability of the enclosure.

### 2.3 MOUNTING THE MULTILOAD II SCS ENCLOSURE:

The SCS enclosure should be located in a shaded area. Direct sunlight can increase internal temperature to greater than 140°F or 60°C.

Exterior dimensions of the enclosure are shown in [Figures 7.1 through 7.3](#). There is only one mounting orientation possible as shown in [Figure 7.1](#). Five M20x 1.5 mm cable entries are located at the bottom of the enclosure.

Appropriate fasteners must be selected to support the minimum weight of 22 lbs (10 kg). Toptech offers the following mounting suggestions for three typical surfaces: metal, wood, or concrete/cinder block.

#### 2.3.1 *METAL PLATE OR RAIL*

Use four hex head 5/16 OD (M8) bolts with a 5/16 flat washer, ¾" OD (M8, 18mm OD) under the head of the bolt. Fasten with four 5/16" (M8) hex nuts.

#### 2.3.2 *Wood*

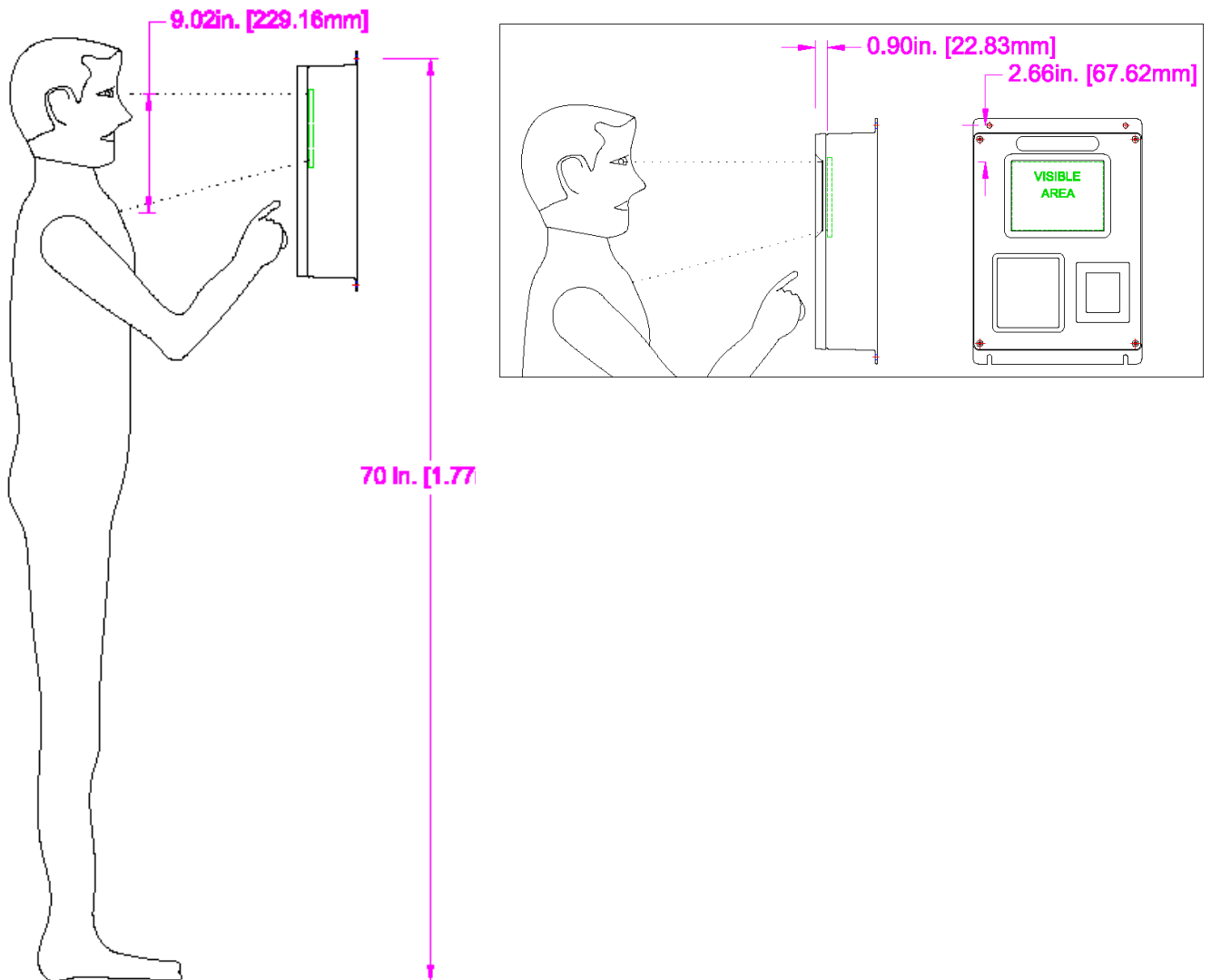
Use four hex head 2" X 5/16 OD (M8 x 50 mm) lag bolts with a 5/16" flat washer, ¾" OD (M8, 18 mm OD) under the head of the bolt. Or, you may drill through holes in the wood and assemble as with the metal plate using four hex head 5/16 OD (M8) bolts with a 5/16 flat washer, ¾" OD (M8, 18mm OD) under the head of the bolt. Fasten with four 5/16" (M8) hex nuts.

### 2.3.3 CONCRETE, SOLID BLOCK, OR BRICK WALLS

Use four 1/4" x 2 1/4" Tapcon, 5/8" diameter hex flange head masonry fasteners with a 1/4" flat washer, 3/4" OD under the head of the screw. Drill pilot holes for the Tapcons using a 3/16" masonry drill bit.

### 2.3.4 MOUNTING HEIGHT CONSIDERATIONS

When mounting the enclosure, be aware of the limitations that the cover places on screen visibility. Because the display is inset about an inch [25mm] from the surface of Div-2 and SCS units and the screen is inset an inch-and-one-half [39mm] in the EXL unit, the enclosure should be mounted so that top of the screen's visible area is at eye level of the tallest operator. Figure 2.1 shows the visible area at arm's length and the distance from the ground to the top mounting hole location for a six foot [1.8m] tall user. Figure 2.2 shows the offset of the top of the screen's visible area from the top mounting bolt and the depth of the screen within the unit.



**Figure 2.1 Suggested Mounting Position and Screen Visible Area**

## 2.4 RECOMMENDED WIRE SIZES AND TORQUE FOR ALL TERMINAL BLOCKS

Three sizes of terminal blocks are used in the MultiLoad II products: 7.62 mm pitch (supply power), 5.08 mm pitch (line voltage switching), and 3.81 mm pitch (serial communication, analog or dc voltages). All sizes, orientations, and manufacturer brands have different torque and wire size specifications. Please follow the recommendations in Figure 2.1 below. The manufacturer may be determined by looking for the logo molded into the terminal block, usually on the side.















Manufacturer	Logo	Terminal Block Pitch	Orientation	Allowable Wire Size	Recommended Screw Torque		Location
		[mm]		[AWG]	[Nm]	[LB in]	
Phoenix		7.62	Straight	30 - 12	.6 - .8	5 - 7	TB1, Power Supply Board
On-Shore Technology		7.62	Straight	24 - 12	0.40	3.5	
Sauro		7.62	Straight	30 - 12	0.8	7	
Phoenix		5.08	Straight	30 - 12	.6 - .8	5 - 7	TB1, I/O Board
On-Shore Technology		5.08	Straight	24 - 12	0.40	3.5	
Sauro		5.08	Straight	30 - 12	0.8	7	
Phoenix		3.81	Straight	30 - 14	0.5	4	TB2 - TB5, Power Supply Board; TB3 - TB6, I/O Board
On-Shore Technology		3.81	Straight	28 - 16	0.19	1.7	
Phoenix		3.81	90°	30 - 14	0.2 - 0.5	2 - 4	TB2A, TB2B, I/O Board
On-Shore Technology		3.81	90°	26 - 16	0.3	3	
Sauro		3.81	90°	30 - 14	0.31	2.7	


Figure 2.2 MultiLoad II Terminal Block Recommended Wire Size and Screw Torque

## 2.5 ELECTRICAL SUPPLY CONNECTIONS

	The SCS may be equipped for either 85 -250Vac or 24Vdc operation. Verify the power type before making any connections.
	To reduce the risk of ignition in hazardous atmospheres, conduit runs must have seals Installed within 18 inches (45 cm) of the enclosure.
	Field wiring must have a temperature rating of 75°C or greater.

### 2.5.1 **CABLE GLAND ENTRIES**

Five M20 x 1.5 mm apertures in the enclosure bottom are provided for the installation of cable glands. A gland with the correct corresponding thread must be installed in the opening.

	<b>WARNING:</b> If there are unused holes, blanking elements satisfying the flameproof “d” method of protection must be used. Blanking elements must be removable with the aid of a tool, ATEX certified, suitable for Gas Group IIB and suitable for an ambient temperature range of -40 C to +60 C.
---	---


Do not route AC and DC wiring in the same conduit.

All wiring must enter the MultiLoad II enclosure through conduit via entries in the bottom of the enclosure. All conduits must be terminated at the enclosure by use of appropriately rated conduit hubs or glands.

Wires must be stripped ¼” and fully inserted into terminal block with no bare conductor exposed. The terminal blocks are designed to accept wires sizes 12 AWG (3.31 mm<sup>2</sup>) through 24 AWG (0.205 mm<sup>2</sup>). The recommended tightening torque is 0.5 Nm [4.4 inch-pound force] to 0.6 Nm [5.3 inch pound-force].

Both ac and dc input models require a safety ground connection as described in section 2.3.3 below.

A service loop is recommended for all wires and cables entering the enclosure.

	<b>Do not allow service loop cables to overlap the circuit boards.</b> Coil any cable length in the bottom of the enclosure. Keep AC wiring separated from all other wiring in the enclosure by use of the supplied partitions (see wire partition instructions below).
---	---

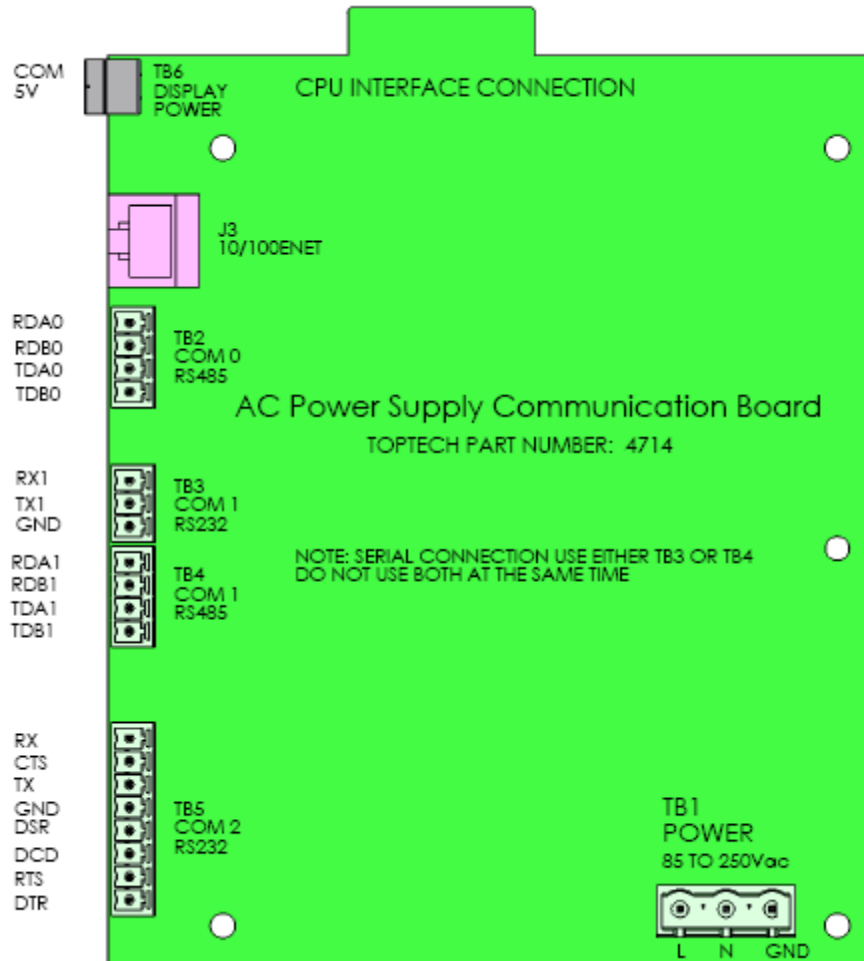
Wiring must comply with all local electrical codes.



### 2.5.2 AC POWERED MODELS

Provide over current protection using a 15 Amp circuit breaker or equivalent. The breaker also serves as a means of disconnection from the operating supply as required by UL/IEC 61010-1 and CAN/CSA-C22.2 NO. 61010-1. The disconnect device may not be blocked or be made difficult to operate by the MultiLoad II or any other device. Note that installation of disconnects are typically prohibited in Class I, Division 2 locations.

Power required: 85 – 250 Vac, 47 – 63 Hz, 300 mA @ 85Vac/ 150 mA @250Vac. The power connector is located in the right hand corner of the Power Supply/Communication board as shown in figure 2.1. Select supply wire rated 300V or better with a flammability rating of at least VW-1.



**Figure 2.3 MultiLoad II AC Power Supply/Comm Board**

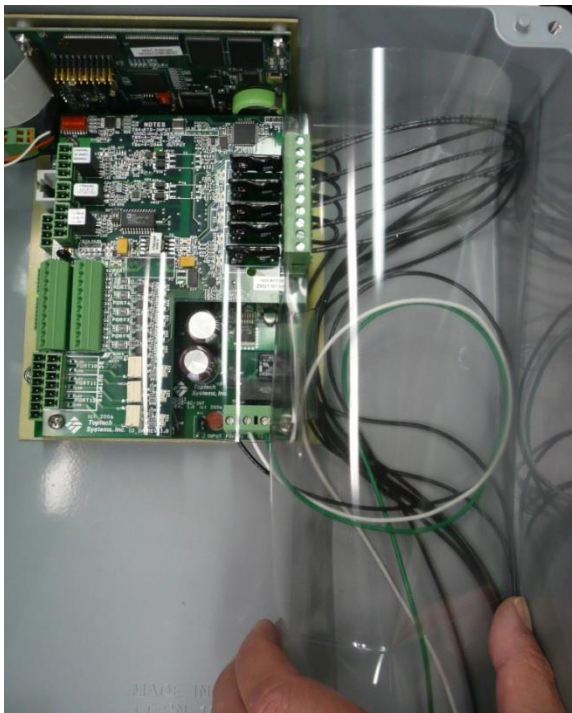
A plastic flap has been installed over TB1 and along the right edge of the enclosure. All services loops or excess AC wiring should be placed under the partition. This includes AC wiring attached to TB1 of the optional I/O board. The figures below illustrate how to gain access to the terminal blocks, and replace the partitions so that wires containing Hazardous voltages are separated from all low voltage circuits (including field wired circuits).



**Figure 2.4** AC Supply Terminal Block Access



**Figure 2.5** Removal of AC Wiring Side Partition

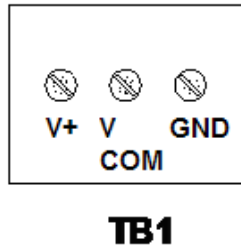


**Figure 2.6** Replacement of AC Wiring Side Partition

### 2.5.3 DC POWERED MODELS

The MultiLoad II is optionally available with a 24 Vdc power supply. The power source used to supply the MultiLoad II must be rated 18 – 36 Vdc SELV, Limited Energy (Class 2). The rated supply input current is 600mA. The supply should be protected by a 1.5 Amp fuse.

The 3 position terminal block is located in the right hand corner of the power supply/communication board.



**Figure 2.7 DC Power Connections**

#### Wiring guidelines for using 24 Vdc power supply:

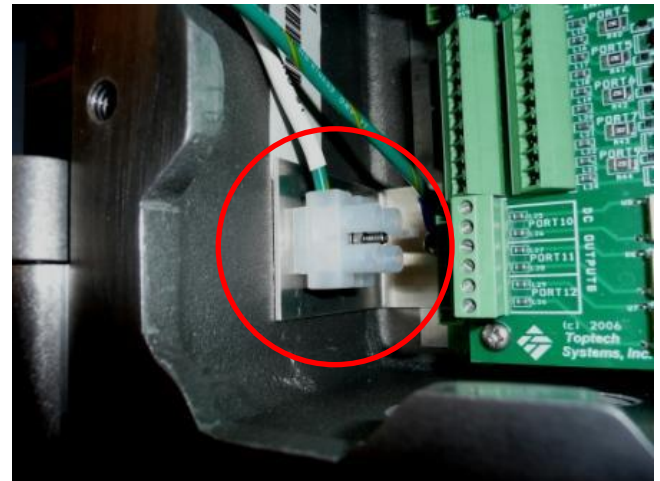
<u>Wire gauge (AWG)</u>	<u>Distance (feet)</u>
24	50
22	100
20	150
18	250
16	400

### 2.5.4 EQUIPMENT GROUNDING

A safety ground should be attached to terminal block TB1 (on both ac and dc input power models) to maintain electrical safety in the event of a fault condition. Follow the terminal block wiring instructions in section 2.5. The required tightening torque is shown in Figure 2.3.

Canadian standards require a dedicated Intrinsic Safety ground wire to be attached to the internal I.S. barrier. Attach as show in Figure 2.9 inside the lower left of the enclosure.

Note that the external ground connection is not provided for the attachment of the protective conductor (the safety ground). Rather, it is provided only as a supplemental bonding connection where local authorities permit or require such a connection, for example, as a means of equipotentiality. The wire connection is on the bottom right exterior surface. The following wire sizes may be used: 10 AWG (5.26 mm<sup>2</sup>) or 11 AWG (4.17 mm<sup>2</sup>).



**Figure 2.8 Canadian I.S. Ground Connection**





Do not connect the power supply dc common to earth ground.

## CHAPTER 3 DATA COMMUNICATIONS INTERFACE

The MultiLoad II has four communications ports (see [Figure 2.4](#)) each with a specific purpose. The following section provides the information required to select and make the wiring connections to the ports.

<u>Communication Port</u>	<u>Interface Type</u>	<u>Typical Function</u>	<u>Terminal (<a href="#">Figure 2.4</a>)</u>
Comm. Port 0	RS-485	Internal I/O board / FCM I / FCM II / PCM Communication	TB2
Comm. Port 1	RS-232 or RS-485	Host Communication (TMS)	TB3 RS-232 TB4 RS-485
Comm. Port 2	RS-232 or RS-485 (2 wire)	Ticket Printer/Data Logger	TB5
Ethernet	10/100MBPS	Host Communication (TMS)	J3 Cat 5 Cable

	If a service loop is used, the maximum wire length in the service loop should not exceed 3 inches [75mm].
	Separate AC and DC wiring by at least 3 inches [75mm]. Do not allow excess wire in the service loop to overhang printed circuit board.

### 3.1 **COMMUNICATIONS PROTOCOL SELECTION AND CONNECTION:**

#### 3.1.1 **RS-422/485:**

RS-422/485 communications protocol is designed for multi-point (i.e. computer to multiple devices, also called multi-dropped) communications up to 4,000 feet (1,220 Meters).

RS-422 requires 4-wires (2 twisted pair) for full duplex communications and utilizes a transmit pair of wires (TDA & TDB) and a receive pair of wires (RDA & RDB).

RS-485 requires 2-wires (1 twisted pair) for half duplex communications and utilizes a single pair of wires (TDA/RDA & TDB/RDB) for transmit and receive.

This manual will typically refer to both RS-422 and RS-485 as simply RS485 2 wire or RS485 4 wire.



Although a ground wire is not required, the common mode voltage between the MultiLoad II and the field device must be within -7Vdc to 12Vdc. To correct situations where this is not the case, the DC common is available on COM 0 and COM 1 by using TB2, pin five (revision 1.1 Power Supply/Comm boards only) and TB 3, pin three. Connect the MultiLoad II DC common to the signal ground of the field device.

Wire used must meet the following characteristics:

- 24 AWG stranded.

- 4-wire, two twisted pair with overall shield.

- 2-wire, one twisted pair with overall shield.

- 30 pF maximum between conductors.

- 1,000 ohm impedance.

- Maximum length: 4,000 feet (1,220 Meters)

- Maximum stub length: 15 feet.

All exposed shields must be properly insulated to prevent short circuits.

All shields must be continuous, soldered and properly insulated.

#### 3.1.2 **RS-232**

RS-232 protocol is designed for point-to-point (i.e., computer to a single device) communications limited to 50 feet requiring a minimum of 3 wires – transmit, receive and ground. Additional wires are required for hardware handshaking when using printers and data loggers.

Wire used must meet the following:

- 24 AWG.

- 3 conductor with overall shield (data only) or 8 conductor with overall shield (full handshaking).

- 30 pF maximum between conductors.

### 3.1.3 FCM I / FCM II / PCM COMMUNICATIONS (COM 0 - RS-485)

FCM I, FCM II and PCM modules are all connected on a RS-485 bus connected to COM 0 on the MultiLoad II. The TD and RD pairs are swapped at the MultiLoad II.

If an internal I/O board is installed, this board is already connected to COM 0 and is addressed as FCM #0.

All FCMs must be uniquely addressed.

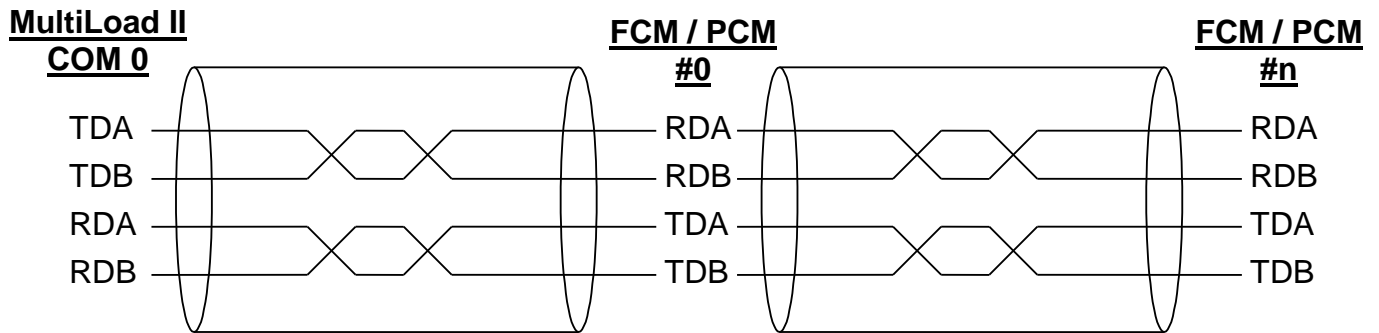


Figure 3.1 FCM / PCM Connections

### 3.1.4 HOST/TMS COMMUNICATIONS (COM 1 - RS-485 4-WIRE)

The Host/TMS Computer System can be connected to the MultiLoad II via RS485 4-wire on COM 1. The TD and RD pairs are swapped at the Host/TMS.

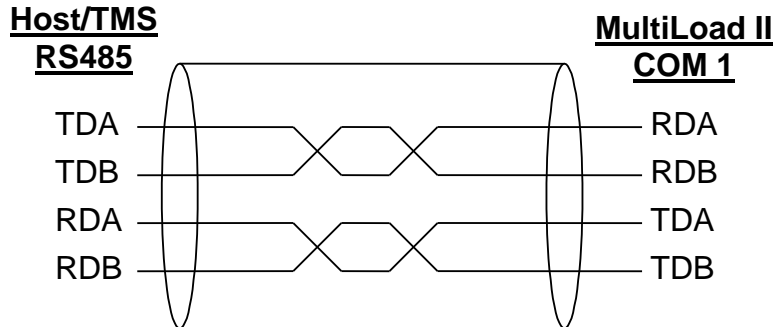


Figure 3.2 RS485 4-Wire, Host to a Single MultiLoad II (recommended)

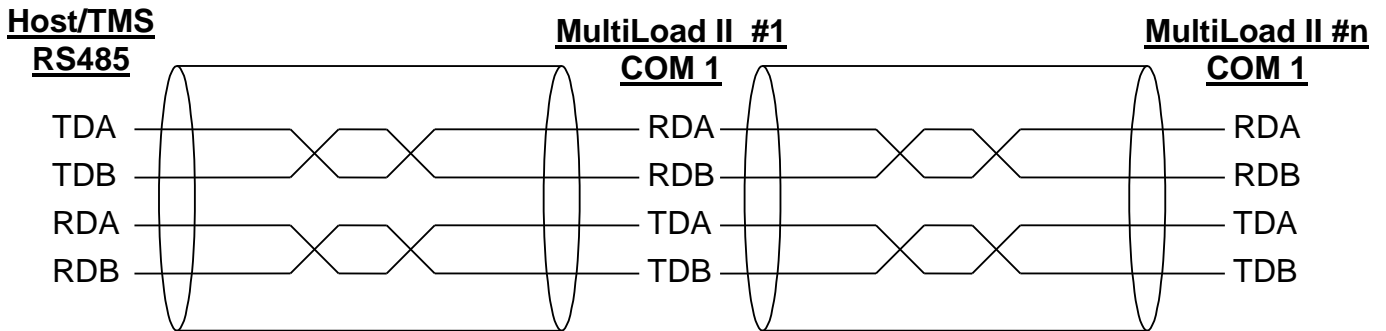
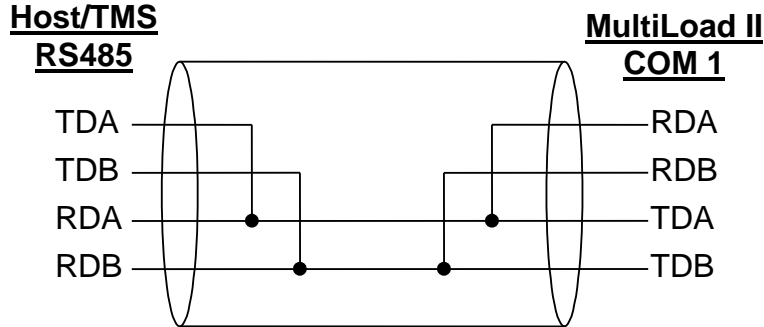


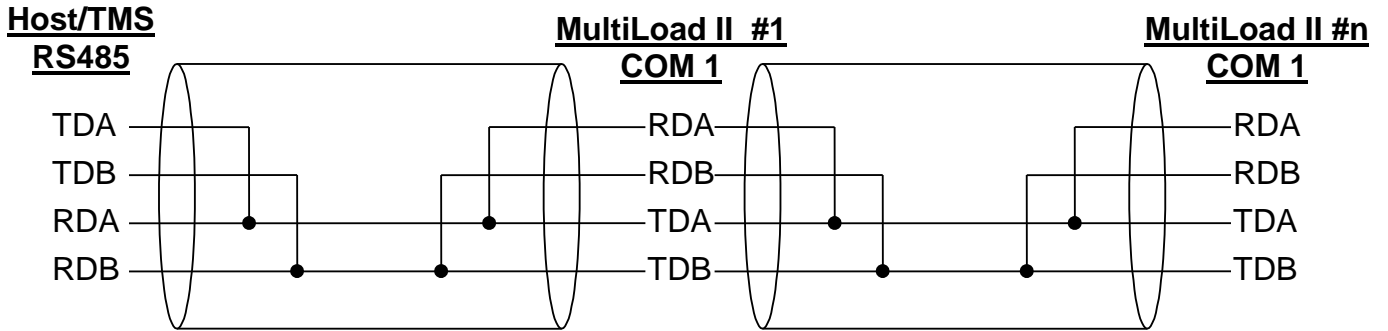
Figure 3.3 RS485 4-Wire, Host to Multiple MultiLoad IIs

**3.1.5 HOST/TMS COMMUNICATIONS (COM 1 - RS-485 2-WIRE)**

The Host/TMS Computer System can be connected to the MultiLoad II via RS485 2-wire on COM 1. The TD and RD pairs tied together at the Host/TMS and all MultiLoad IIs.



**Figure 3.4 RS485 2-Wire, Host to a Single MultiLoad II**



**Figure 3.5 RS485 4-Wire, Host to Multiple MultiLoad IIs**



### 3.1.6 Host/TMS COMMUNICATIONS (COM 1 - RS-232)

The Host/TMS Computer System can be connected to the MultiLoad II via RS232 on COM 1.

The TX and RX are swapped at the Host/TMS.

MultiLoad II has the ability to multi-drop onto a RS232 line.

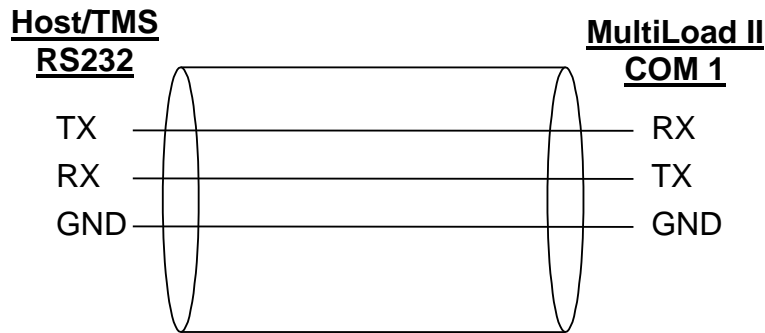


Figure 3.6 RS232, Host to a Single MultiLoad II

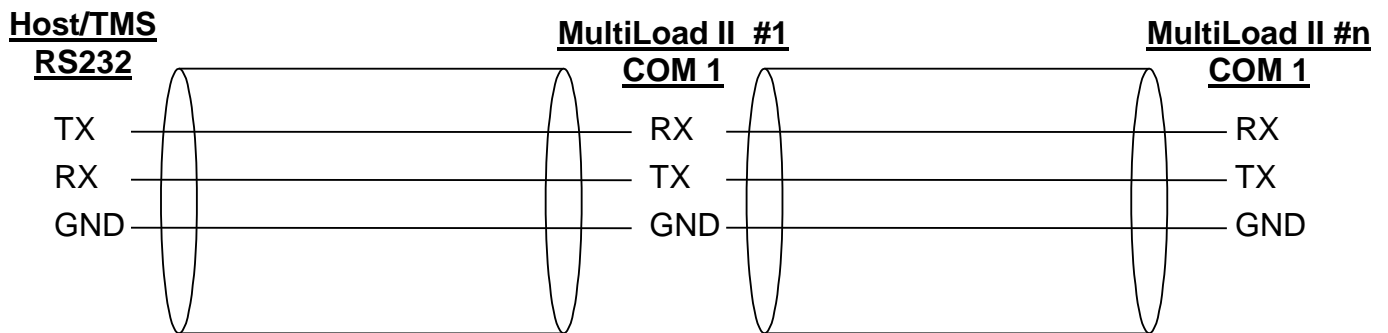


Figure 3.7 RS232, Host to Multiple MultiLoad IIs

### 3.1.7 HOST TICKET PRINTER/DATA LOGGER (COM 2 - RS-232)

A Ticket Printer or Data Logger can be connected to the MultiLoad II via RS232 on COM 2.

The TX and RX are swapped at the MultiLoad II.

Handshake lines MUST be connected or terminated or a Printer Error will be reported.

MultiLoad II will monitor CTS, DSR and DCD for active signals.

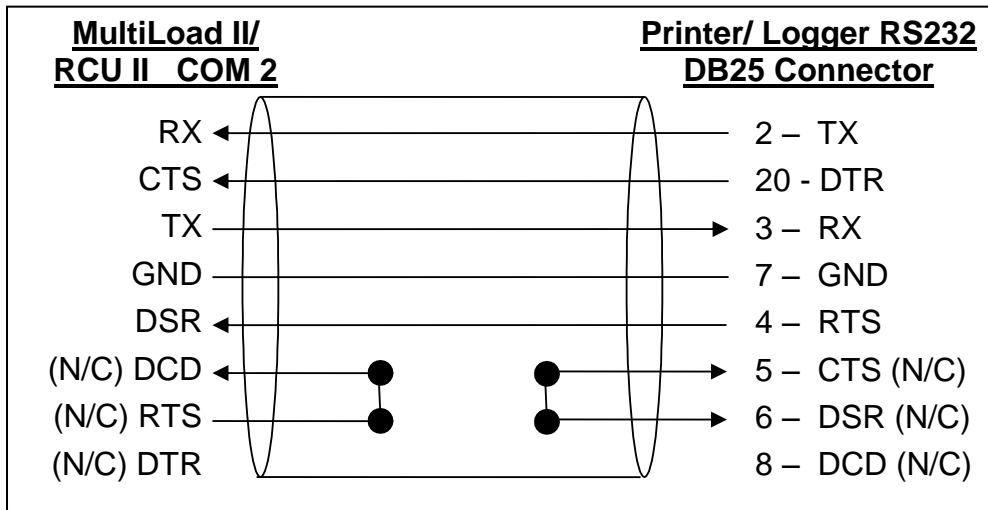


Figure 3.8 Ticket Printer / Data Logger Connections with Handshake

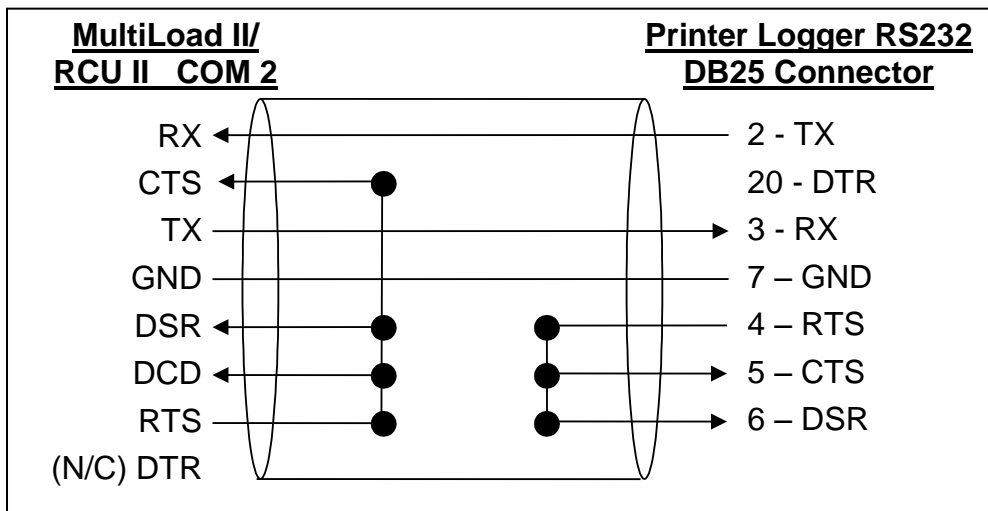


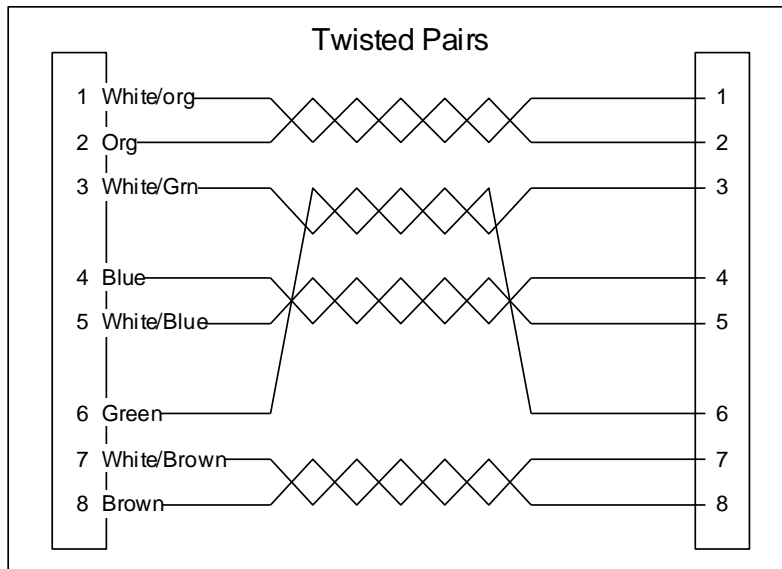
Figure 3.9 Ticket Printer / Data Logger Connections without Handshake

### 3.1.8 ETHERNET

Ethernet wiring standard T568B - Cat5 cable (or greater).

Figure 3.10 illustrates the required connections for Ethernet.

The Ethernet controller on revision 2.0 CPU boards uses HP Auto-MDIX technology. By automatically detecting the signaling on the connected device, the transceiver will configure the port settings automatically. Thus, the choice of a straight through or cross over cable no longer has to be made—either will work.



**Figure 3.10 Ethernet Connections**

## CHAPTER 4 I/O CONFIGURATION

### 4.1 CONNECTING FIELD DEVICES TO THE I/O BOARD

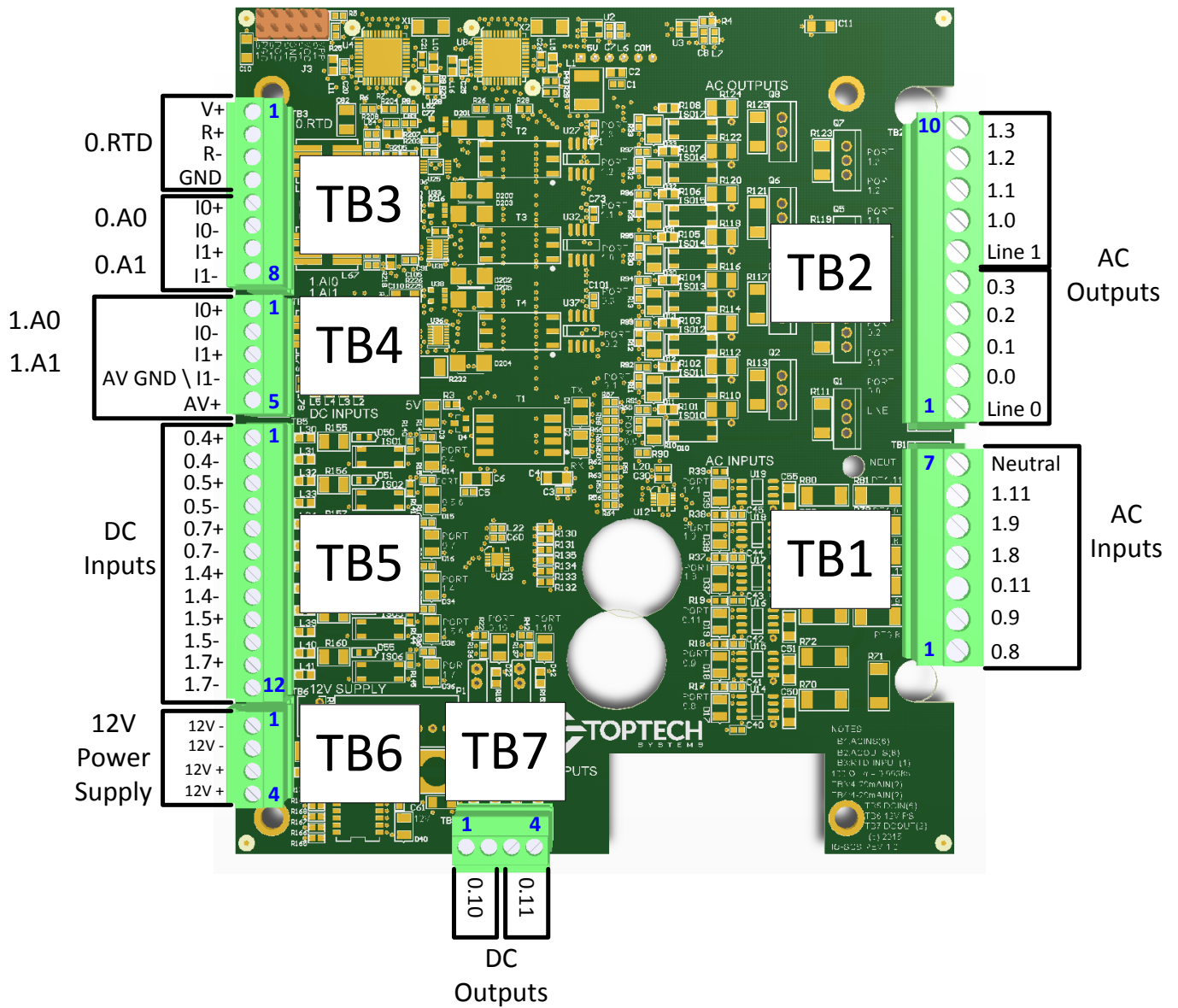
The I/O board is mounted above the Power Supply/Comm board. The I/O board is connected to the Power Supply/Comm board at J4 & J5. Corresponding connections are on bottom side of the I/O board.



**Disconnect from the supply circuit before opening enclosure.  
Keep tightly closed when circuits are live.**

The quantity and electrical ratings of the I/O are described in the table below.

TYPE I/O	QUANTITY, LOCATION	ELECTRICAL RATING
AC Outputs:	8 (TB2)	12 - 250 Vac rms, 500 mA (per point)
AC Inputs:	6 (TB1)	90 - 250 Vac rms, 500 mA (per point)
DC Outputs:	2 (TB7)	0 - 30 Vdc, 600 mA (per point)
DC Inputs:	6 (TB5) (4 High Speed)	5 - 30Vdc Dual Channel flow meter inputs (1-5000Hz)
12 Vdc Source:	(TB6)	3 W, 250 mA Max Load
RTD Input:	1 (TB3)	100-ohm platinum, four wire Coefficient 0.00385 Ohm/Ohm/°C
Analog Input: 4-20 mA	4 (2 TB3 and 2 TB4)	4 - 20mA, 1.5V maximum burden (2.3 V MAX VOLTAGE)
Analog Input: 1-5 V	1 (TB4)	1 - 5 V



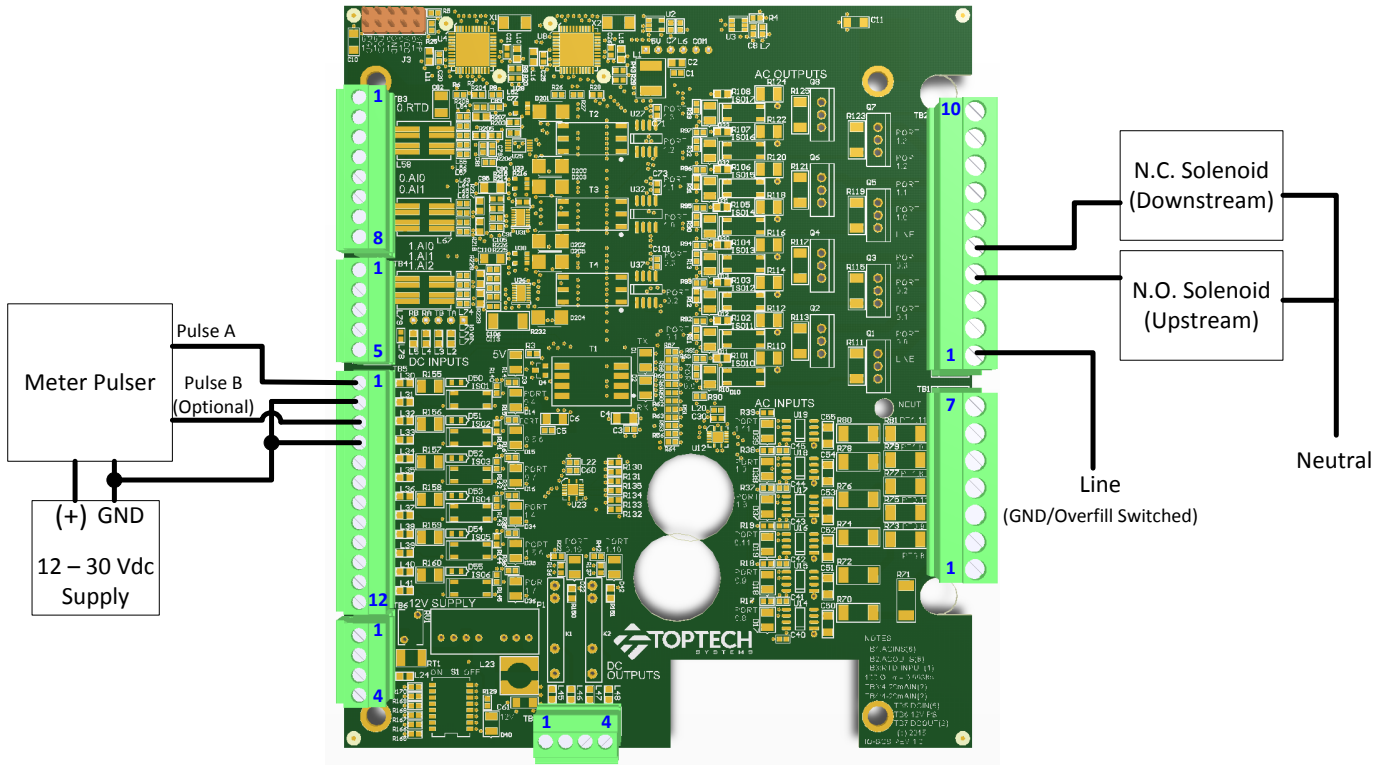
**Figure 4.1 SCS I/O Board Terminal Block Assignments**



Note:

1. TB3: Analog input port 1.A1 can be configured as a 4-20mA input or a 1-5 Analog Voltage input. If using 4-20mA, use TB4 pin 3 & pin 4. If using 1-5V, use TB4 pin 5 and pin 4.
2. TB1: Neutral is shared for all AC inputs.
3. TB2: Line 1 is shared for ports 1.0 - 1.3, and Line 0 is shared for ports 0.0 – 0.1

4.1.1 MULTILoad II FLOW METER AND CONTROL VALVE WIRING



TB5			
Port		Pin No.	Assignment
0.4	+	1	Pulse A
	-	2	Supply Common
0.5	+	3	Pulse B (Optional)
	-	4	Supply Common

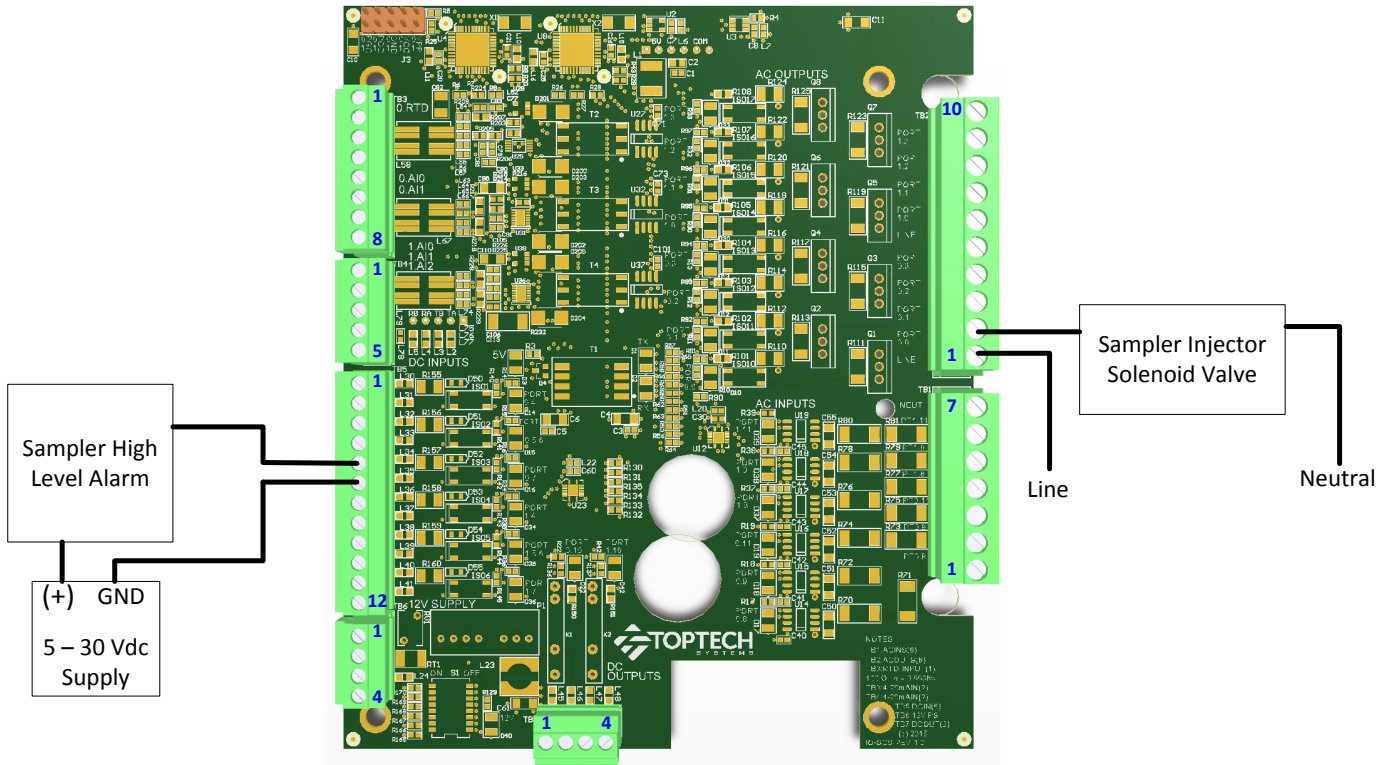
TB2		
Port	Pin No.	Assignment
N/A	1	Line Voltage (GND/Overfill Switched)
0.2	4	N.O. Solenoid (Upstream)
0.3	5	N.C. Solenoid (Downstream)

Figure 4.2 SCS I/O Board Field Wiring: Flow Meter and Control Valve



**Caution:** Line voltage used to drive the Digital Valve Solenoids MUST be controlled by the Ground or Overfill monitor. In the event of a Ground loss or Overfill detection, this voltage must be switched off to ensure a failsafe shutdown of the product flow.

4.1.2 MULTILOAD II SAMPLER WIRING

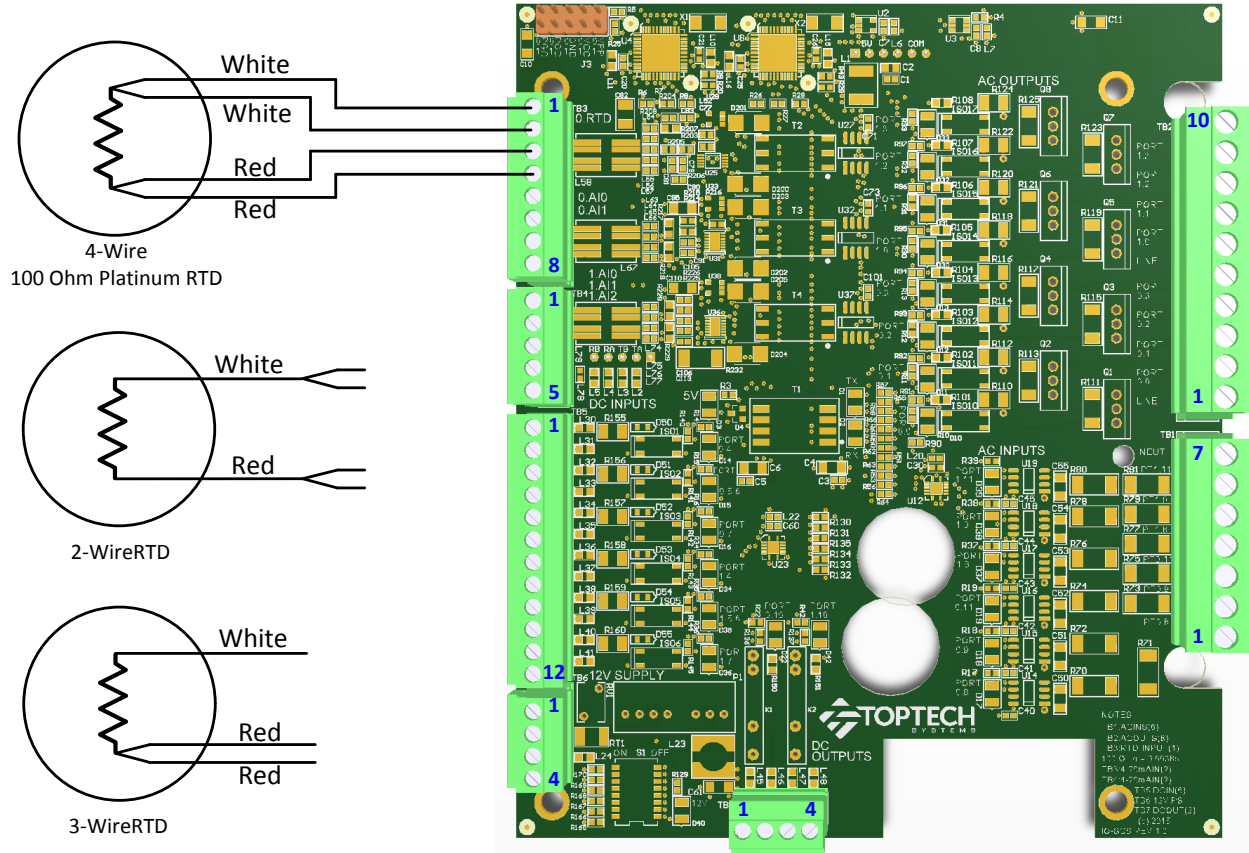


TB5			
Port		Pin No.	Assignment
0.7	+	5	Sampler High Level Switch
	-	6	Supply Common

TB2		
Port	Pin No.	Assignment
N/A	1	Line Voltage
0.0	2	Sampler Injector Solenoid Valve

Figure 4.3 SCS I/O Board Field Wiring: Sampler Valves

4.1.3 MULTILoad II RTD TEMPERATURE PROBE WIRING



TB3			
Port		Pin No.	Assignment
0.RTD	V+	1	White Wire
	R+	2	White Wire
	R-	3	Red Wire
	GND	4	Red Wire

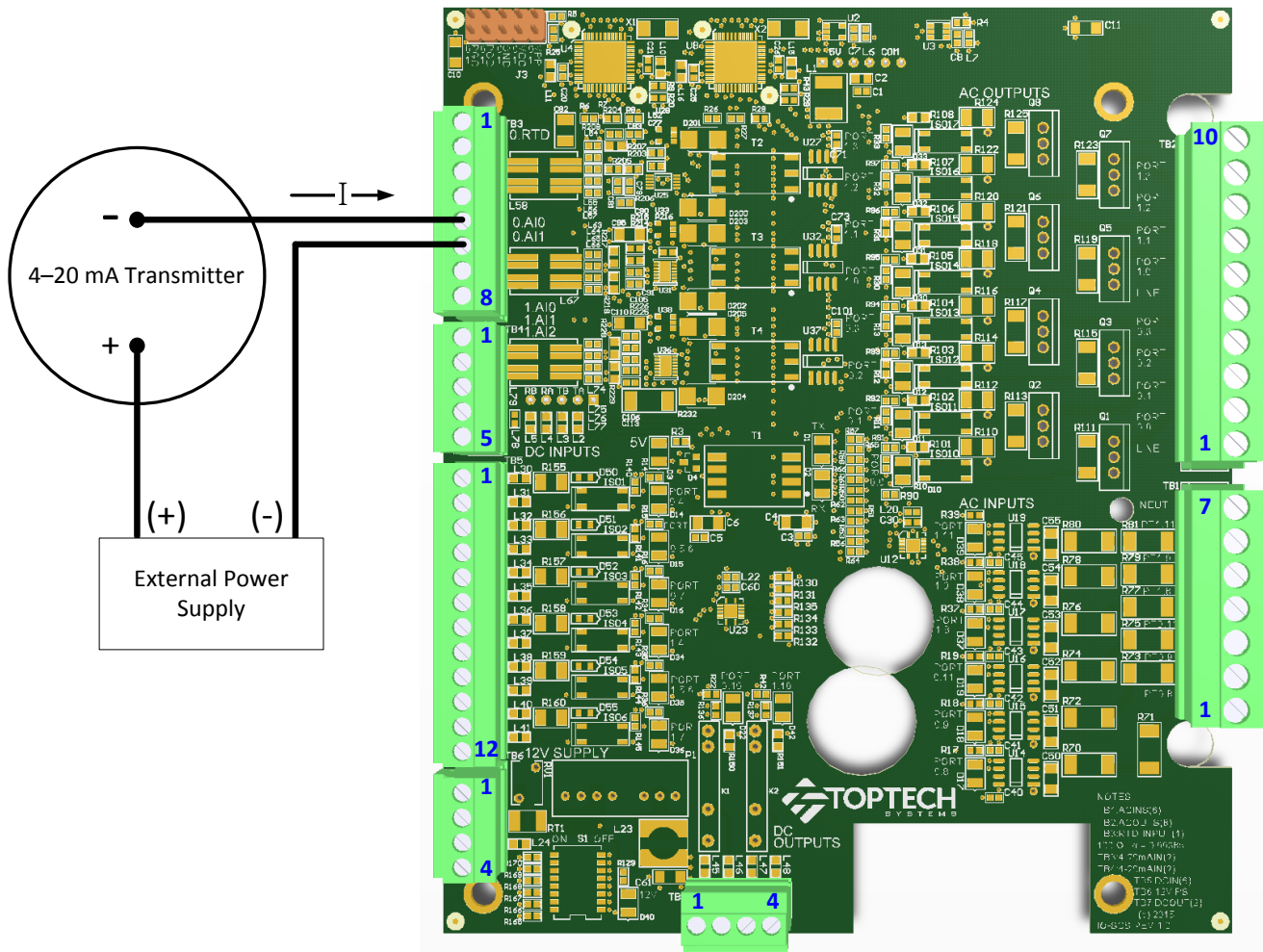
Figure 4.4 SCS I/O Board Field Wiring: RTD



**Note:** All 4 wires MUST be run to the sensor. Do not simply jumper REF- to COM or REF+ to V+ at the SCS I/O Board. For 3-wire and 2 wire probes, the connection of REF- to COM and REF+ to V+ should be as close as possible to the probe (within inches).



4.1.4 MULTILoad II 4-20mA INPUT WIRING: LOOP CURRENT PROVIDED BY EXTERNAL POWER SUPPLY



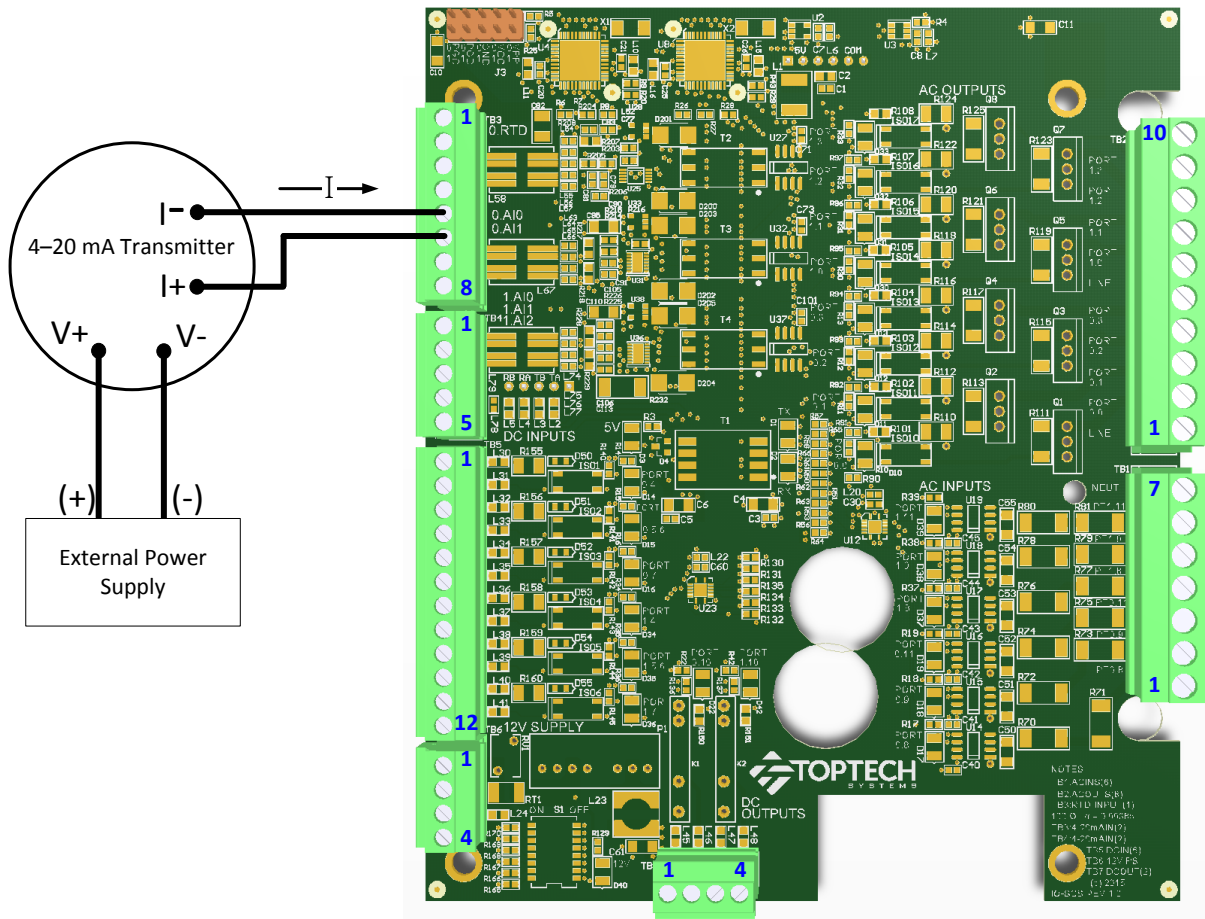
TB3			
Port		Pin No.	Assignment
0.A0	I0+	5	Output of Transmitter
	I0-	6	GND from Supply

Figure 4.5 SCS I/O Board Field Wiring: 4-20mA Input



**Note:** The receiver does not contain a voltage source. The loop must be powered either by the transmitter or by an external power supply. The I/O Board adds 75 Ohms to the loop

4.1.5 MULTILOAD II 4-20mA INPUT WIRING: LOOP CURRENT PROVIDED BY TRANSMITTER



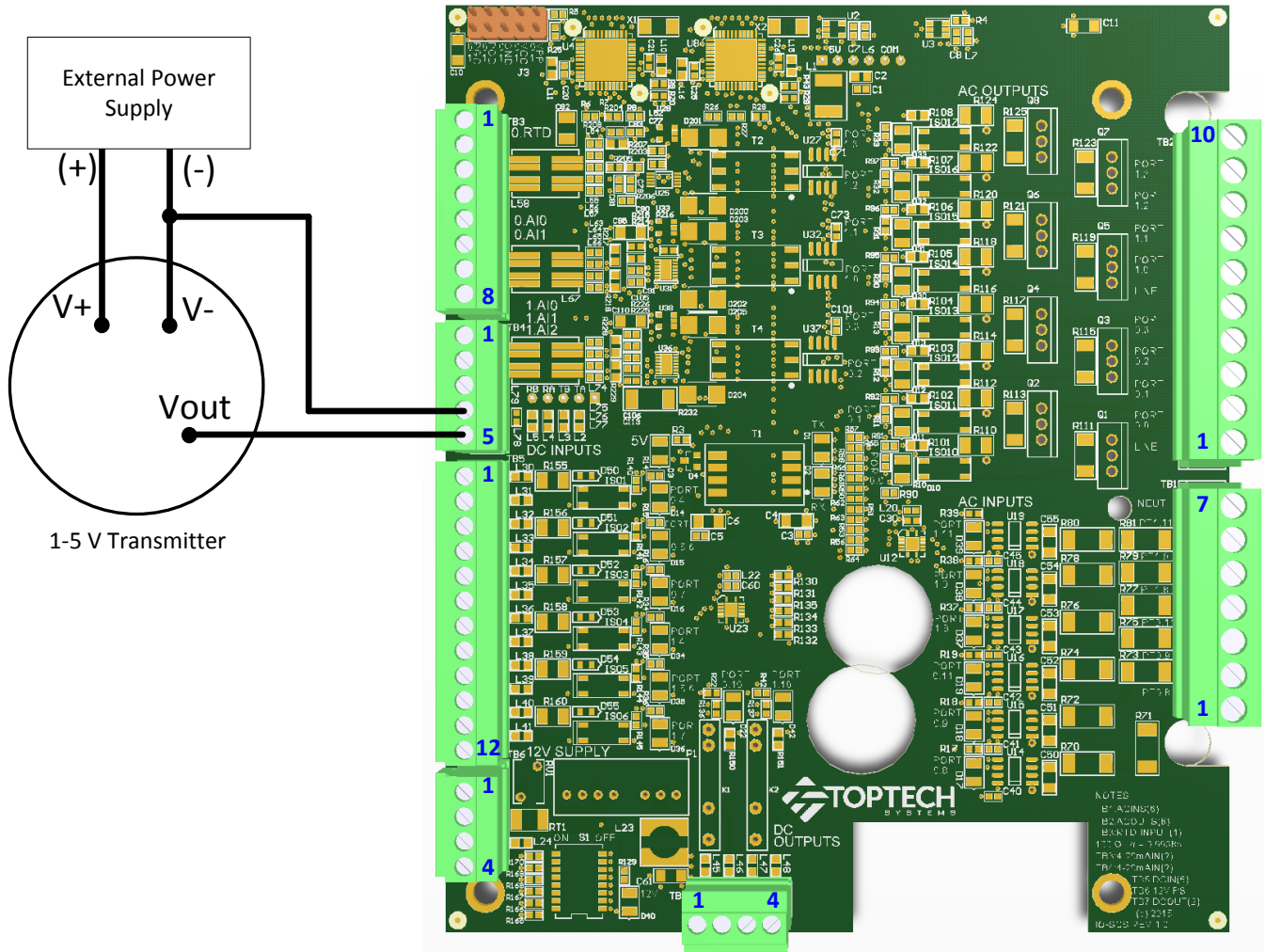
TB3			
Port		Pin No.	Assignment
0.A0	I0+	5	Output of Transmitter
	I0-	6	Return path to Transmitter

Figure 4.6 SCS I/O Board Field Wiring: 4-20mA Input



**Note:** The receiver does not contain a voltage source. The loop must be powered either by the transmitter or by an external power supply. The I/O Board adds 75 Ohms to the loop

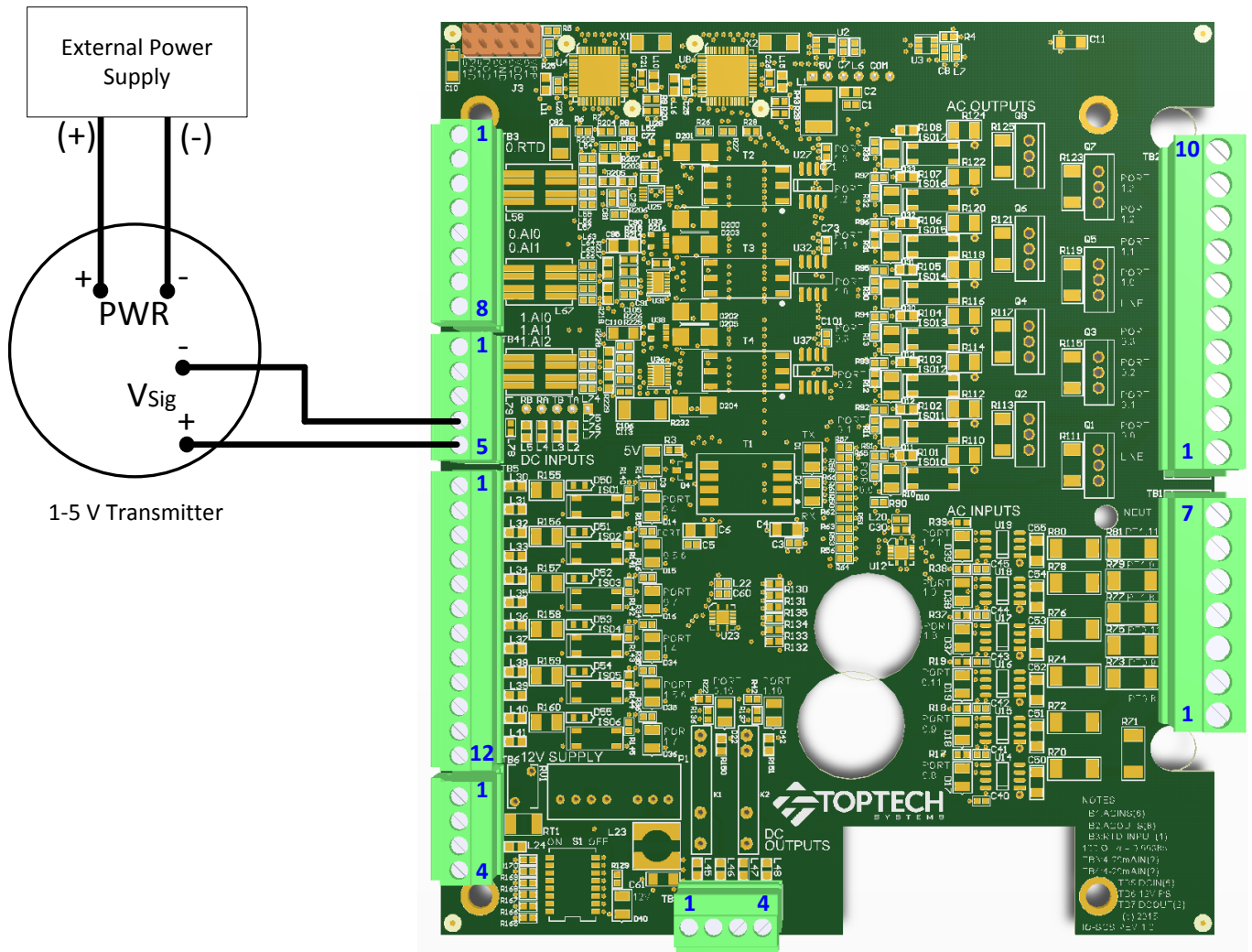
**4.1.6 MULTILoad II 1-5 V INPUT WIRING: SINGLE WIRE OUTPUT**



TB4			
Port		Pin No.	Assignment
1.A1	AV GND	5	GND of Power Supply
	AV+	6	Voltage Output of Transmitter

**Figure 4.7 SCS I/O Board Field Wiring: 1-5 V Input**

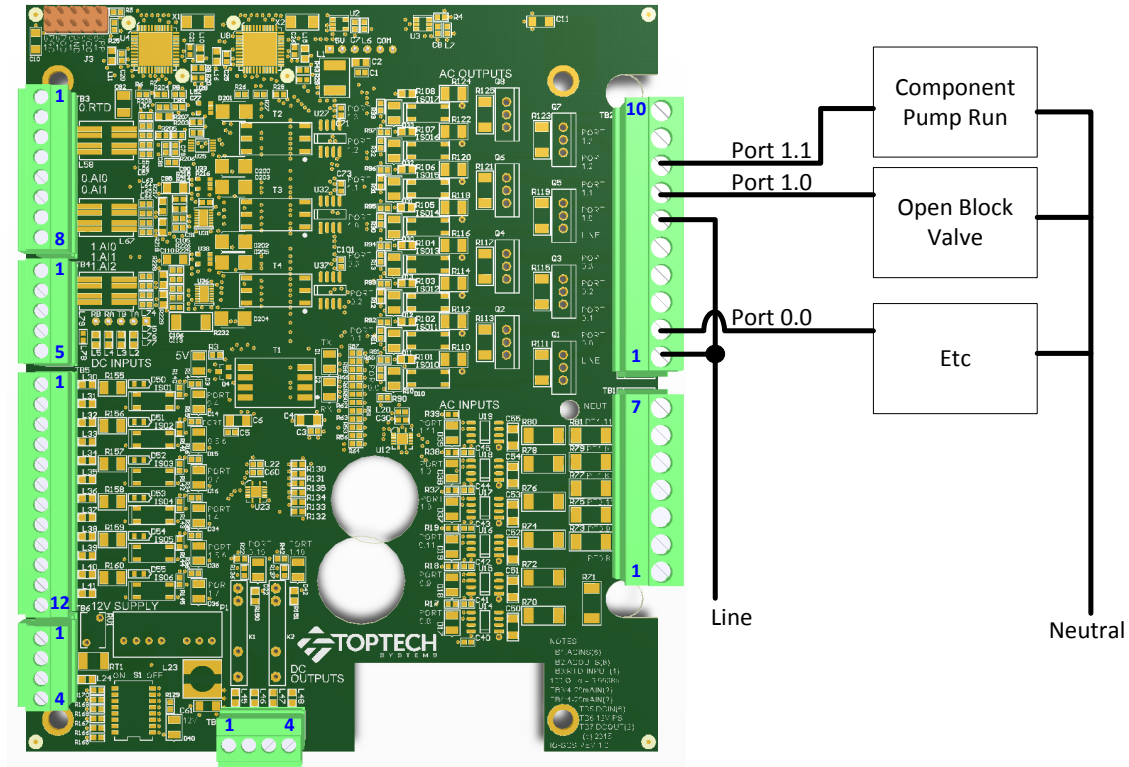
**4.1.7 MULTILoad II 1-5 V INPUT WIRING: TWO WIRE OUTPUT**



TB4			
Port		Pin No.	Assignment
1.A1	AV-	5	Signal Ground
	AV+	6	Signal V+

**Figure 4.8 SCS I/O Board Field Wiring: 1-5 V Input**

4.1.8 MULTILOAD II AC OUTPUT WIRING



TB2		
Port	Pin No.	Assignment
N/A	1	Line Voltage
0.0	2	Etc
N/A	6	Line Voltage
1.0	7	Open Block Valve
1.1	8	Component Pump Run

Figure 4.9 SCS I/O Board Field Wiring: AC Pump and Block Valve Control



Note:

1. This shows a typical configuration. AC outputs can be assigned to any unused AC output ports. Flow Control Valves MUST be wired to ports x.2 and x.3.
2. The Line Voltage coming in on TB 2 pin 1 is shared among pins 2 – 5 (Ports 0.0 – 0.3), and the Line Voltage coming in on TB2 pin 6 is shared among pins 7 – 10 (Ports 1.0 – 1.3).



4.1.9 MULTILoad II AC INPUT / 3 OUTPUT AIR ELIMINATOR WIRING

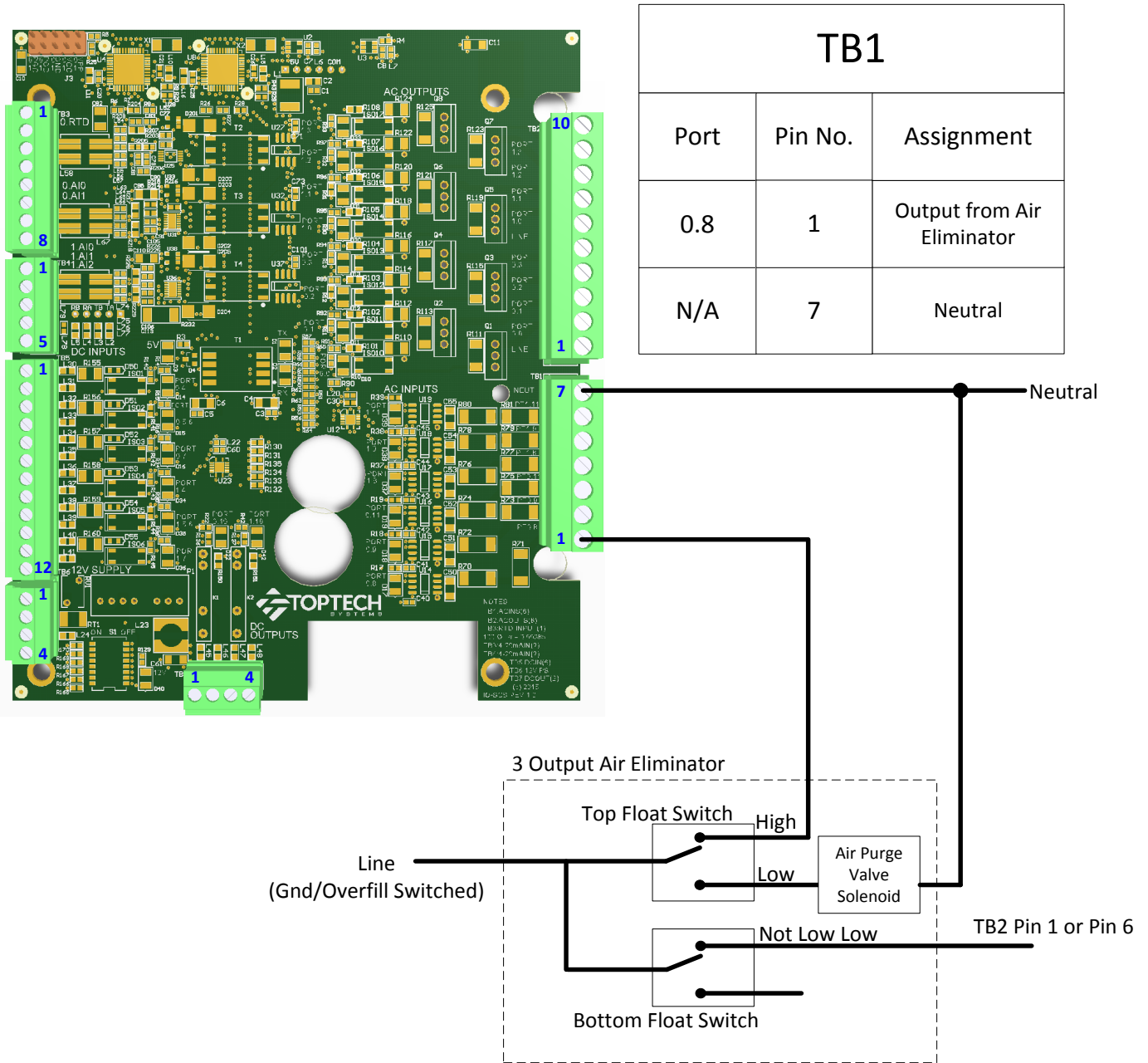


Figure 4.10 SCS I/O Board Field Wiring: AC Input / Air Eliminator



**Note:**

This shows a typical configuration. Neutral is shared across inputs and is located on TB2 pin 7.

4.1.10 MULTILoad II DC INPUT WIRING

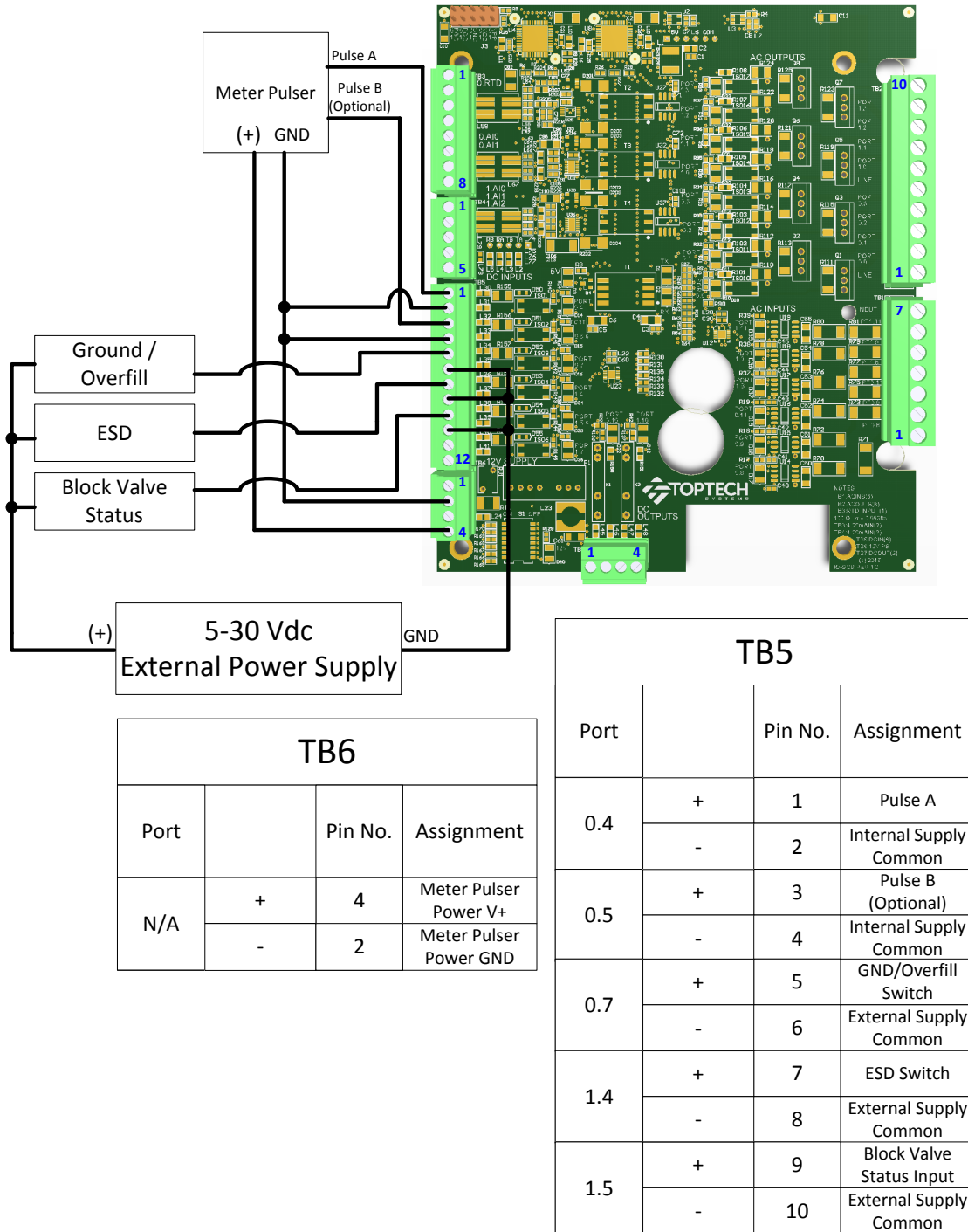


Figure 4.11 SCS I/O Board Field Wiring: DC Input



**Note:** This shows a typical configuration. DC Permissive/Status inputs can be assigned to any unused DC input.

4.1.11 MULTILoad II DC OUTPUT WIRING

TB7			
Port		Pin No.	Assignment
0.10	+	1	V+ from External Supply
	-	2	Pulse Output
1.0	+	3	V+ from External Supply
	-	4	Open Block Valve Output

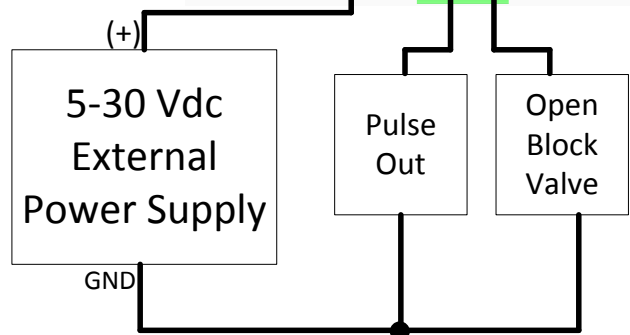
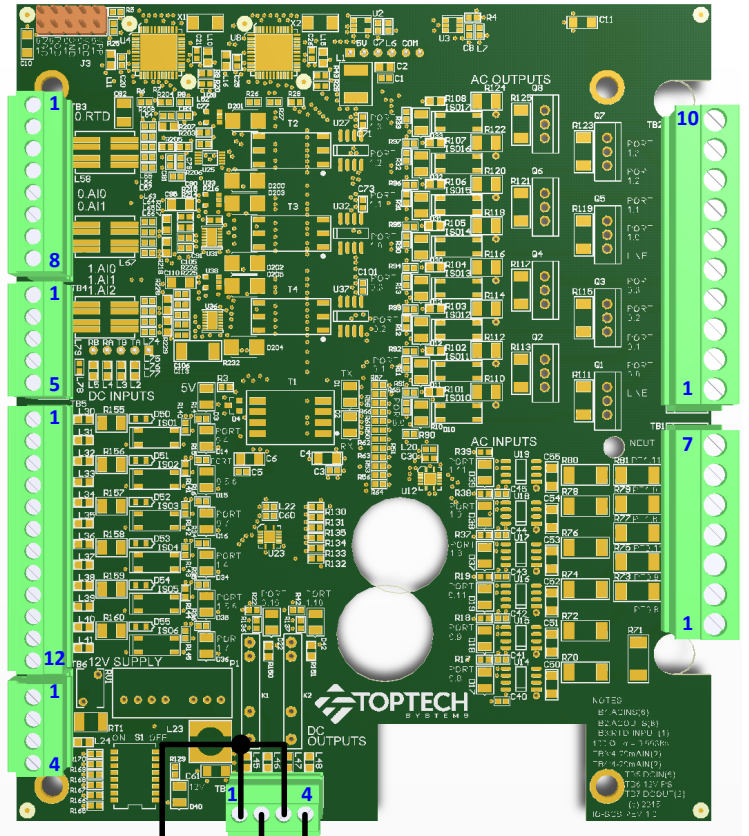


Figure 4.12 SCS I/O Board Field Wiring: DC Output



**Note:** This shows a typical configuration. DC outputs can be assigned to any unused DC output.



## CHAPTER 5 CONFIGURATION

The following describes how to navigate the system, select field values, perform data entry, and toggle options on and off.

### 5.1 SWITCH ACCESS CONTROL

The MultiLoad II SCS contains switches which limit menu and configuration access. These switches limit users from accessing Program Mode and as well as from changing Weights and Measures controlled parameters.

In Program Mode the operator has access to the following:

- The Configuration Menu parameters
- The Diagnostics Menu and its functions
- Other administrative procedures, such as clearing high-level alarms.

To access Program Mode, the MultiLoad II terminal operator must:

1. Move the Program Mode switch into the active position.
2. At the idle card in screen, enter the security code (default security code is 000000) and press the <Next> key.

#### 5.1.1 EXTERNAL SWITCH ACCESS CONTROL

One access control switch option is a pair of external access control switches. These switches limit access to Program Mode and changes to Weights and Measures controlled parameters.



**YOUR LOCAL WEIGHTS AND MEASURES OFFICE MAY NEED TO BE CONTACTED AFTER BREAKING THE SEAL AND CHANGING PARAMETERS. THIS IS TYPICALLY DONE ONLY DURING METER PROVING OR TEMPERATURE CALIBRATION.**

Depending on the date of manufacture, the MultiLoad II SCS may have one of three types of external switch design. All can be sealed and locked to prevent access to Program Mode and to prevent changes of Weights and Measures controlled parameters.

### 5.1.2 EXTERNAL TYPE 1 PROGRAM / W&M SWITCHES

This design consists of two separate external rotary switches, one for Program Mode Access, and one for W&M change access. Each switch has external fold down cover that can be locked or sealed with a wire and lead seal to prevent moving the switch into the active state. Each cover will also be stamped as “W&M” or “Program” to indicate function.



Figure 5.1 Type 1 Program / W&M Switches

### 5.1.3 EXTERNAL TYPE 2 PROGRAM / W&M SWITCHES

This design consists of a single 3-position external rotary switch with two individual covers which may be locked and sealed with a wire and lead seal. The covers limit the switch rotation to three positions.

A Two covers closed: Program access denied and Weights and Measures access denied

B First cover open: Program access allowed and Weights and Measures access denied

C Both covers open: Program access allowed and Weights and Measures access allowed.

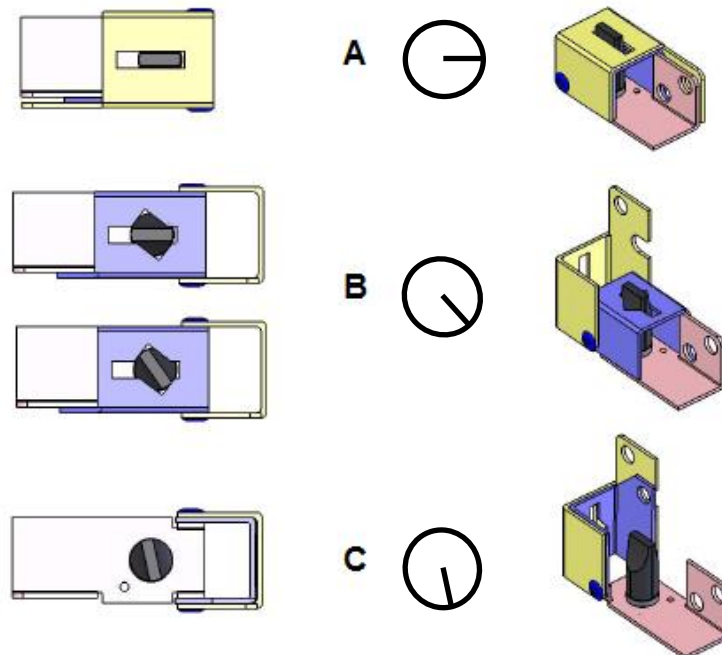


Figure 5.2 Type 2 Program / W&M Switches

#### 5.1.4 EXTERNAL TYPE 3 PROGRAM / W&M SWITCHES

The third design consists of two separate external magnetic bolts, one for Program Mode Access, and one for W&M change access. Program or W&M access is achieved by removing the corresponding bolt. Each bolt has a small hole that can be sealed with a wire and lead seal to detect unauthorized access. A single fold down cover can be locked to prevent bolt removal. The cover is marked "W&M" or "Program" adjacent to each bolt to indicate the bolt function.



Figure 5.3 Type 3 Program / W&M Switches



**Do not use a wrench to tighten the bolts. Insert the bolts hand tight only. Over tightening will damage the bolt assembly.**

**HAND TIGHTEN ONLY!**



### 5.1.5 INTERNAL SWITCH ACCESS CONTROL

Two DIP switches on the CPU board also provide the closure of the Program Mode / W&M switch contacts. When the MultiLoad II does not have the external Program Mode / W&M switch installed, it is necessary to use these DIP switches on the CPU board to enable program mode and W&M access.

The switches are numbered 1 through 4 with 1 being closest to the front of the enclosure (top of the picture), and 4 being toward the back of the enclosure (bottom of the picture).

When switch is in the ON position, the switch is in the active state, allowing access. A switch is ON when it moved right, and OFF when moved to the left.

Switch #3 is the program mode switch. Switch #4 is the W&M access switch. In the example in Figure 5.4 below, the Program Mode switch is currently Active, while the W&M Switch is not active. Figure 5.5 shows the location of the DIP switch on revision 2.0 CPU boards.



	A switch input is active when either the DIP switch OR the external switch is active (ON).
	Your Weights and Measures inspector may wish to verify that DIP switch 4 (bottom switch) is in the off position (moved left) prior to sealing the MultiLoad II SCS enclosure. This will ensure that W&M parameters are secure.



Figure 5.4 CPU DIP Switches for Program and W&M Access (rev 1.0)



Figure 5.5 CPU DIP Switches for Program and W&M Access (rev 2.0)

### 5.1.6 FIELD SWITCH ACCESS CONTROL

The MultiLoad II SCS also has the ability to accept field inputs for the Program Mode and W&M Access switches. See the "MultiLoad II User Guide" for more information.

## 5.2 MULTILOAD II/ RCU II EXL KEYPAD

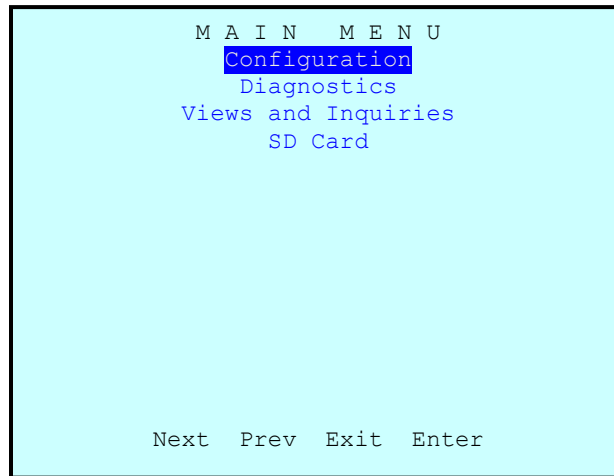
The MultiLoad II SCS keypad has 18 keys, including numeric and function keys, used to:

- Select menu items and fields
- Enter data in fields
- Initiate actions
- Return to previous screens

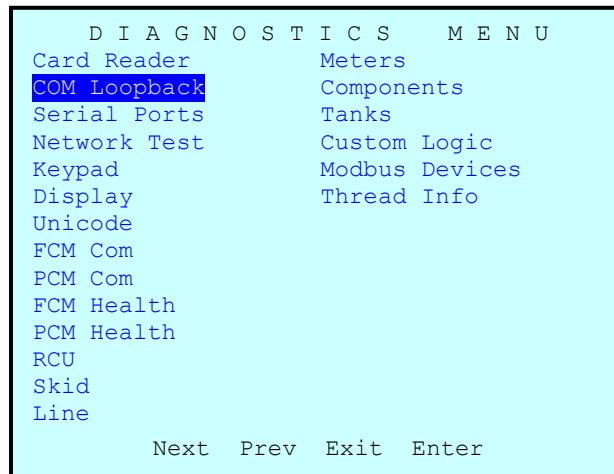
Numeric keys (**1** through **9** and **0**) are used to enter numeric data. Alpha keys are used to enter text, and also to select/deselect alpha character entry. The decimal point ( **.** ) is used to enter numeric field data with a decimal point. **CLR** key is used to clear data entered in error. The **CLR** key is a backspace key erasing characters as the cursor moves backward.

### 5.3 MENUS AND SCREENS

The MultiLoad II Main Menu is shown below. From this menu, you select submenus.



The reverse video highlight bar indicates the current selection. Press **Next** to select Diagnostics, and then press the **Enter** key to go to the Diagnostics Menu.



For menu options and function screen items, pressing the **Next** key moves the selection bar down, and pressing the **Prev** (Previous) key moves the selection bar up.

To return to the Main Menu, press **EXIT**. To return to any previous screen, press the **EXIT** key.

## 5.4 FIELD MODIFICATION AND DATA ENTRY

MultiLoad II will have all fields populated with default values. There are two types of fields, toggle or data entry. Toggle fields contain a number of choices. Scroll through the choices by pressing the **Enter** key. Data entry fields require that a value be entered into the field, within a given, applicable range. In the example below, RCU Address field is highlighted.

```
RCU GENERAL SETUP
RCU Address: 001
Card Reader: DISABLD
Processing Mode: StndAln
SCS Prompting: None
Terminal Name: Toptech Terminal
Security Accounts

Next Prev Exit Enter
```

Press **ENTER** to choose the field. A blinking cursor indicates data can be entered.

```
RCU GENERAL SETUP
RCU Address: █
Card Reader: DISABLD
Processing Mode: StndAln
SCS Prompting: None
Terminal Name: Toptech Terminal
Security Accounts

Enter Exit
```

Type in the new value (e.g. 123) and press **ENTER**. The new value displays on the screen.

```
RCU GENERAL SETUP
RCU Address:          123
Card Reader:         DISABLD
Processing Mode:     StndAln
Processing Mode:     StndAln
SCS Prompting:      None
Terminal Name:      Toptech Terminal
Security Accounts

Next  Prev  Exit  Enter
```

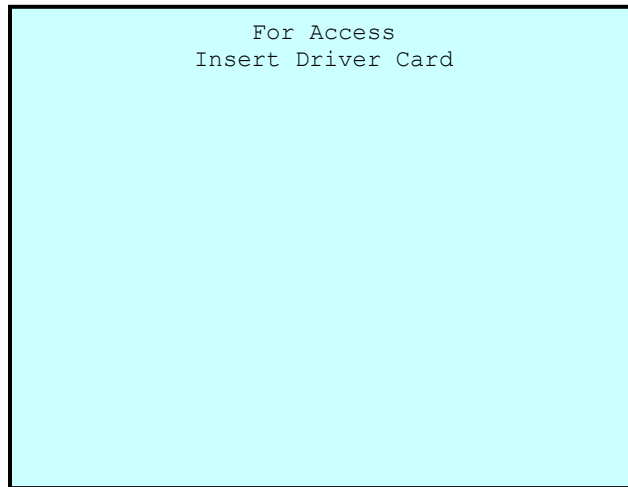
Using this same screen as an example, the Processing Mode parameter is selected, and **ENTER** is pressed. Use the **NEXT** or **PREV** keys to toggle between the values Remote, StndAln, and UAP, as shown below. You must then press **ENTER** to accept the desired choice.

```
RCU GENERAL SETUP
RCU Address:          123
Card Reader:         DISABLD
Processing Mode:     StndAln
SCS Prompting:      None
Terminal Name:      Toptech Terminal
Security Accounts




Enter  Exit
```

## 5.5 MULTILOAD II PRELIMINARY CONFIGURATION:

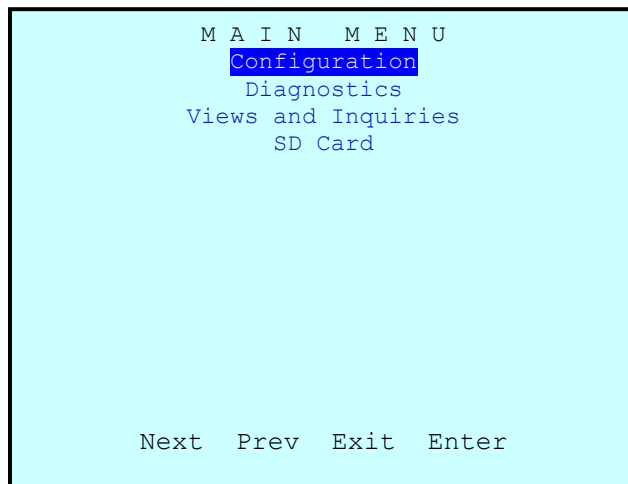
- 1) Energize the MultiLoad II.
- 2) When the MultiLoad II is first energized the Card-in screen appears, indicating Operating Mode.



- 3) Go to program mode by entering **00000** on the keypad, then press **Next**.

	A MultiLoad II must have the Program switch set to allow access to Program Mode (See section 5.1).
	<b>00000</b> is the factory default access code. See the "MultiLoad II User Guide," RCU General setup section for changing or adding new access codes.
	Note that unlike MultiLoad II, Program switches or CPU DIP switches never deny access to RCU II Program Mode.

- 4) The program mode main menu displays.



- 5) Press **Enter** to access the Configuration menu.



- 6) Press **Enter** to access RCU General Setup/ RCU Setup.

```

C O N F I G U R A T I O N   M E N U
Communication
Network
RCU General Setup
RCU Setup
Security Setup
Equipment Setup
Tank Setup
FCM Type Setup
Alarm Setup
Products
Access ID's
Custom Logic
Customer Logo Setup
Date & Time
Next  Prev  Exit  Enter

```

- 7) Press **Enter** and key in **RCU address** (001) of MultiLoad II/ RCU II.

```

RCU GENERAL SETUP
RCU Address: 001
Card Reader:  DISABLD
Processing Mode:  StndAln
SCS Prompting:  None
Terminal Name:  Toptech Terminal
Security Accounts

Next  Prev  Exit  Enter

```

- 8) Press **Exit** to return to the Configuration Menu.  
9) Select and press **Enter** to return to the Main Menu.  
10) If MultiLoad II/ RCU II has Program/Weights and Measures switch, return the switch to Operating Mode.

## 5.6 VERIFY COMMUNICATIONS BETWEEN MULTILoad II AND I/O BOARD:

- 1) Enter program mode by pressing **00000** on the keypad, then press **Next** key.
- 2) Select diagnostics from main menu.

```

      D I A G N O S T I C S   M E N U
Card Reader           Meters
COM Loopback         Components
Serial Ports         Tanks
Network Test         Custom Logic
Keypad              Modbus Devices
Display             Thread Info
Unicode
FCM Com
PCM Com
FCM Health
PCM Health
RCU
Skid
Line

                Next  Prev  Exit  Enter

```

- 3) Select FCM COM

```

004           FCM COM DIAGNOSTICS
              00-Ok

                                Exit

```

- 4) If screen display is the same as above, the I/O board is communicating with the MultiLoad II.
- 5) If I/O board is not communicating the message 00-ERR appears.
- 6) If 00-ERR (or "I/O Board Com: ERR") appears, verify the communication parameters for Com0 within the Communication Setup Menu. This menu is located under the Configuration Menu. The Com0 communication settings required for the I/O board are .57.6 (K Baud), None (Parity), 8 Data (bits), 1 Stop (bit), Single, and I/O Board (type of serial device). This is correctly set in the factory when an SCS is assembled, but it is possible for the settings to be updated by the installer.

## **5.7 USING I/O DIAGNOSTICS**

**MultiLoad II:** Consult MultiLoad II User manual for diagnostics functions.

## CHAPTER 6 SERVICE AND REPAIR

### 6.1 MODULAR DESIGN:

The MultiLoad II SCS has been constructed with replaceable modules or sub-assemblies that are available from Toptech (see Appendix for part numbers). These include:

- CPU Subassembly (CPU Chassis, CPU Board, Power Supply / COM Board, I/O Board).
- Display Subassembly (Active Matrix Display and Display Board)
- Keypad
- Keypad Barrier Circuit

The following sections describe how to remove and replace each subassembly and where possible, how to further disassemble the subassembly



**NOTE:** Do not service MultiLoad II/ RCU II without disconnecting the supply circuit. Keep enclosure tightly closed while circuits are live.

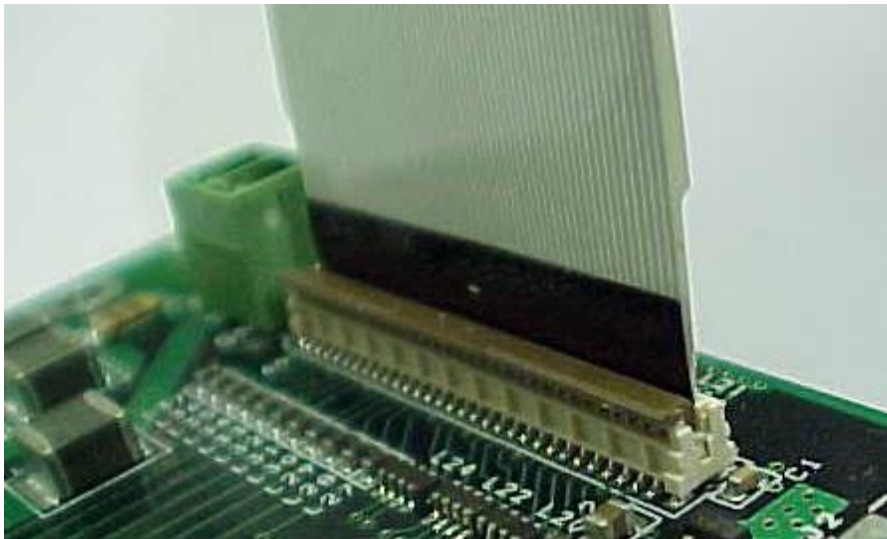
#### 6.1.1 OPERATING THE FLAT DISPLAY CABLE CONNECTORS:

##### Removal:

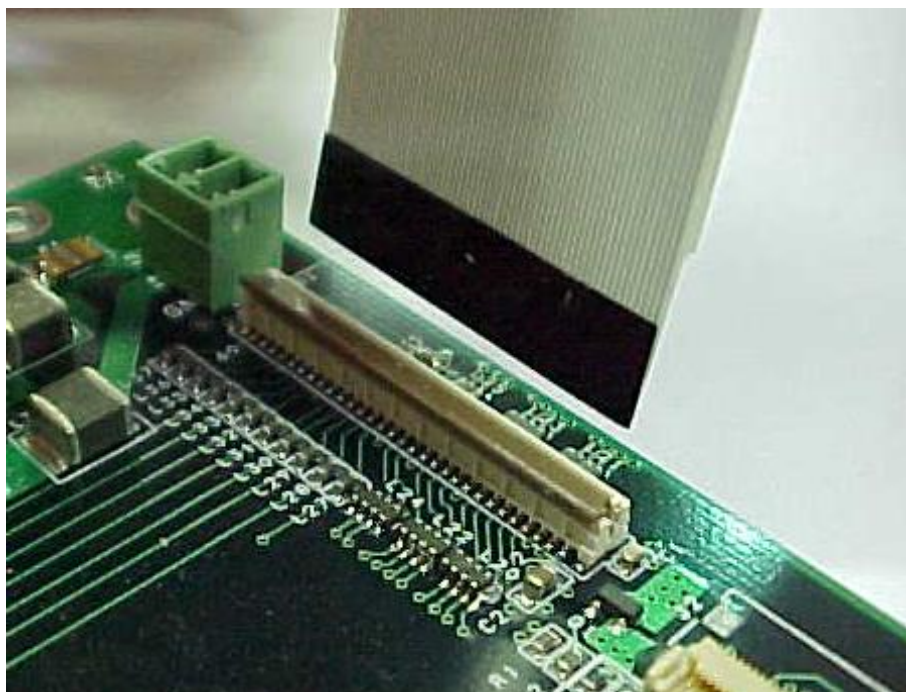
1. To remove the Display Cable rotate the cam to the open (up) position (see Figure 6.1).
2. Gently pull the cable straight out free of the connector.

##### Installation:

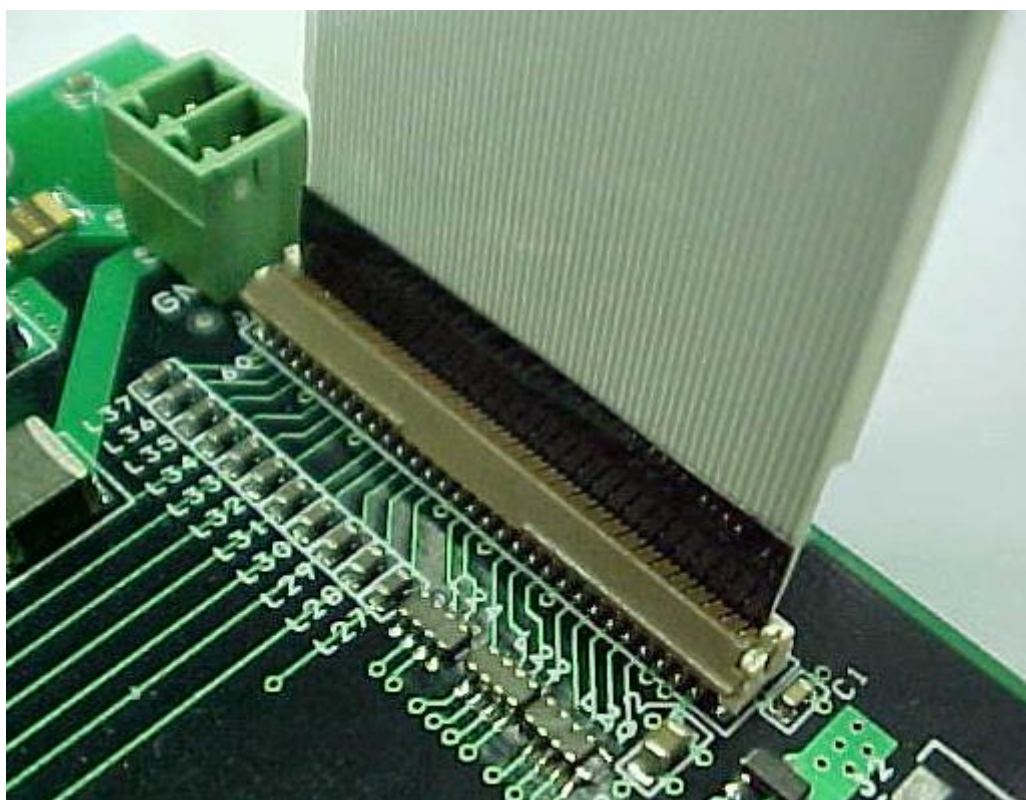
1. To install the display cable make sure the cam is in the open (up) position.
2. Gently insert the cable with the dark insulated side towards the cam (see Figure 6.2). When inserting the cable make sure that it is not tilted to one side or the other and that the bottom of the cable is completely seating in the connector.
3. Rotate the cam to the closed (down) position to lock in place (see Figure 6.3).



**Figure 6.1** Cam lock in the Open (Up) position



**Figure 6.2** Display Cable Insertion



**Figure 6.3** Cam lock in the closed (down) position

### **6.1.2 CPU SUBASSEMBLY REMOVAL AND REPLACEMENT:**

NOTE: Using a magnetic screwdriver is very helpful in retaining the screws during removal and installation.

#### **Removal:**

1. Disconnect all field wiring from the I/O board.
2. Disconnect all Serial Communications from the Power Supply/COM board.
3. Disconnect Mains Power from the Power Supply/COM board.
4. Disconnect the flat display cable (after releasing the cam lock) and display power cable.
5. Disconnect the W&M Access/Program Mode switch cable from the CPU board.
6. Remove the four chassis mounting screws (not the mounting screws for the I/O board or Power Supply / COM board).
7. Carefully remove the CPU chassis from inside the base by removing the CPU board side of the chassis first.

#### **Installation:**

1. Carefully insert the CPU chassis back into the enclosure.
2. Install the chassis mounding screws.
3. Connect the W&M Access/Program Mode switch cable to the CPU board.
4. Reconnect the display power cable and the flat display cable (remember to secure the cam lock).
5. Connect the Mains Power to the Power Supply/COM board.
6. Connect all Serial Communications to the Power Supply/COM board.
7. Connect all field wiring to the I/O board.

### **6.1.3 DISPLAY SUBASSEMBLY REMOVAL AND REPLACEMENT:**

#### **Removal:**

1. Disconnect the flat display cable (after releasing the cam lock), display power cable and the keypad cable.
2. While supporting the display subassembly, remove the four mounting screws.
3. Do not attempt to disassemble the display subassembly. Return entire subassembly to Toptech for repair after receiving an RMA number.

#### **Installation:**

1. While supporting the display subassembly, install the four mounting screws.
2. Connect the keypad cable, display power cable and the flat display cable.
3. Verify routing and clearance of the cable

**6.1.4 KEYPAD REMOVAL AND REPLACEMENT:****Removal:**

1. Using a security screwdriver bit (available from Tiptech), remove all security screws holding on the Keypad bezel.
2. Remove the bezel.
3. Using a flat screwdriver, carefully pry out the keypad.
4. Disconnect the keypad cable from the back of the keypad.

**Installation:**

1. Connect the keypad cable to the back of the keypad.
2. Carefully install the keypad into the cover.
3. Install the keypad bezel.
4. Using a security screwdriver bit, install all the bezel holding security screws.

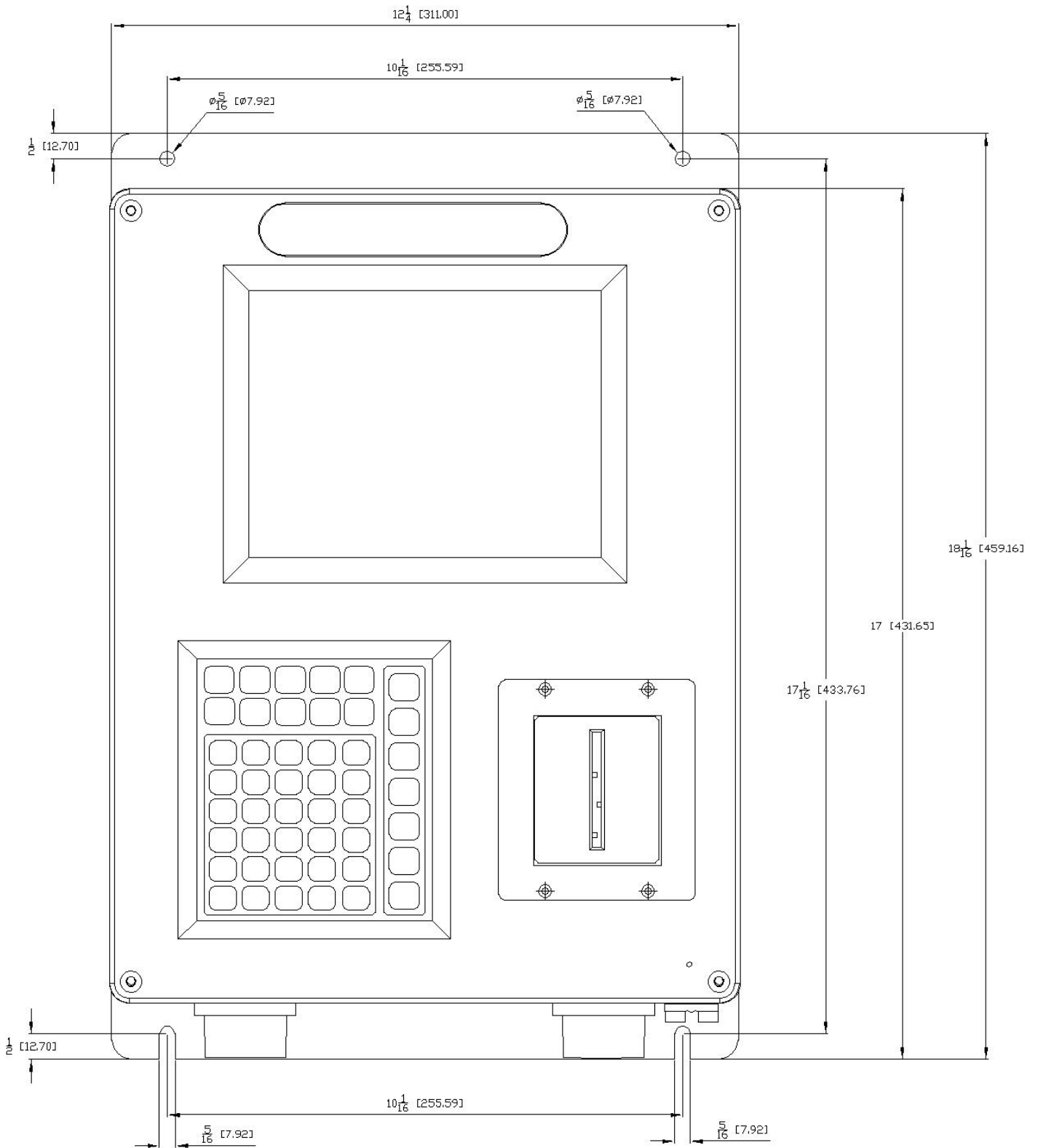
**6.1.5 KEYPAD BARRIER CIRCUIT REMOVAL AND REPLACEMENT:****Removal:**

1. Disconnect the keypad cable from the display subassembly.
2. Remove the four screws holding barrier circuit box.
3. One by one, move over the keypad wires to a new barrier circuit.

**Installation:**

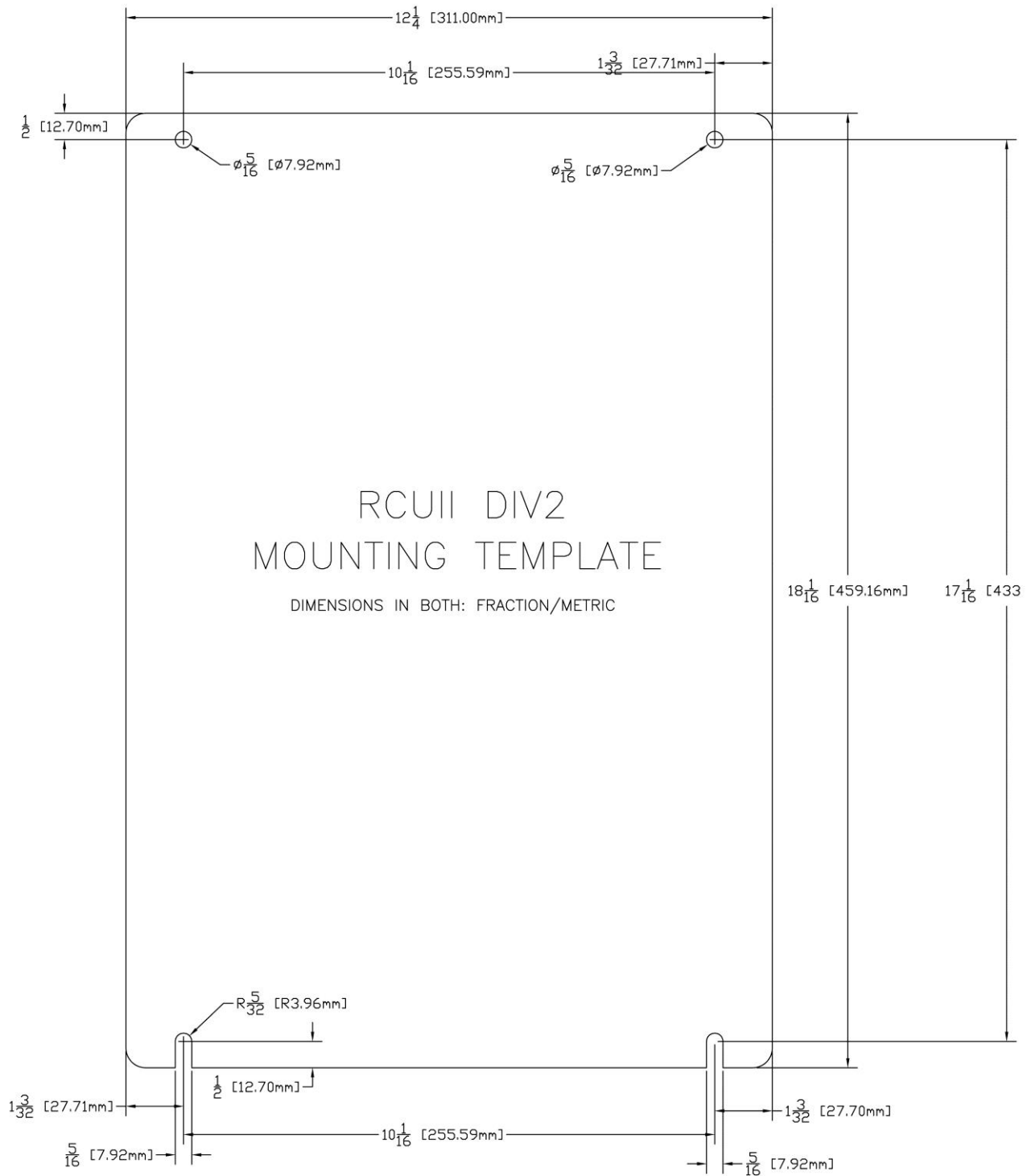
1. Reinstall the barrier circuit box with the three holding screws.
2. Connect the keypad cable to the display subassembly.

# CHAPTER 7 DRAWINGS AND PART NUMBERS

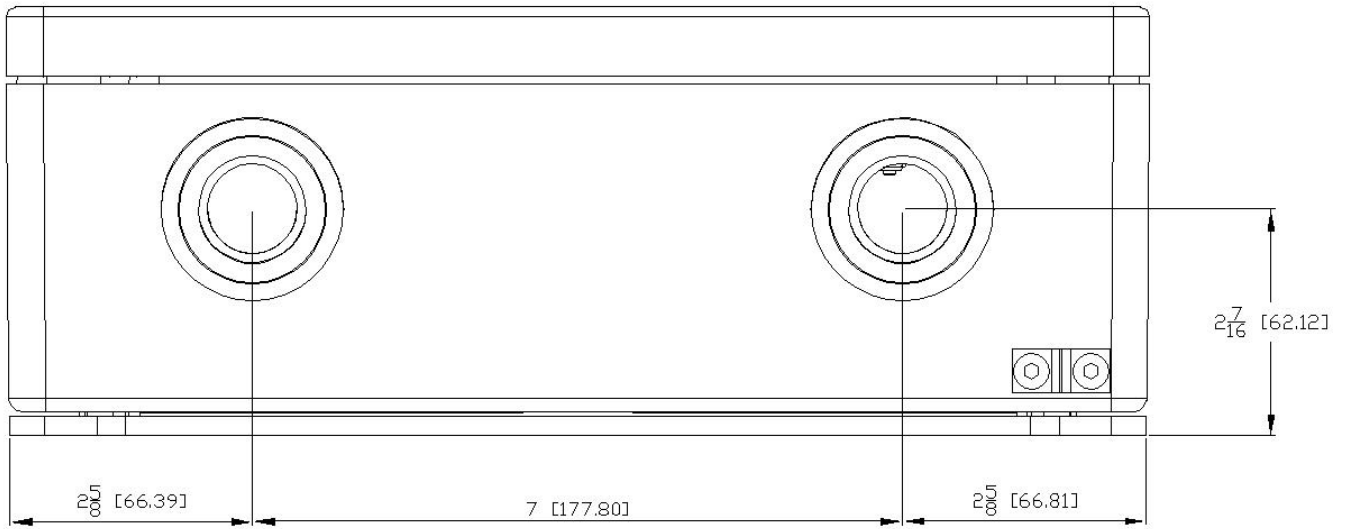


**Figure 7.1 Unit Outline Drawing – Front View**

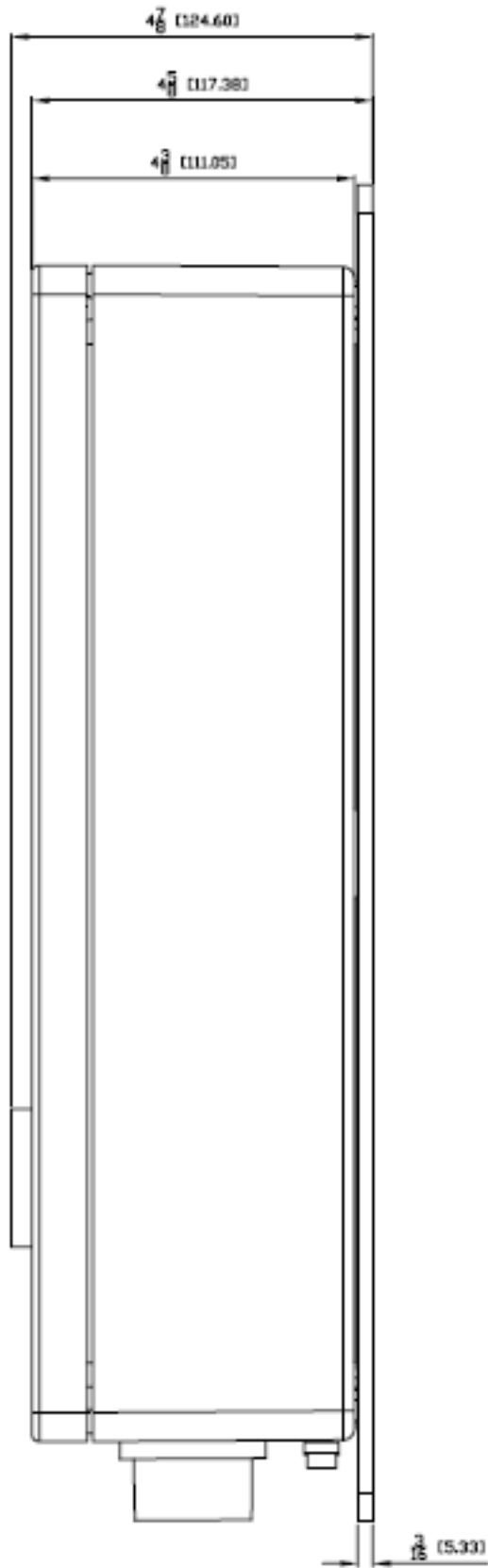




**Figure 7.2 Unit Outline Drawing – Back View**



**Figure 7.3 Unit Outline Drawing – Bottom View**



**Figure 7.4 Unit Outline Drawing – Side View**

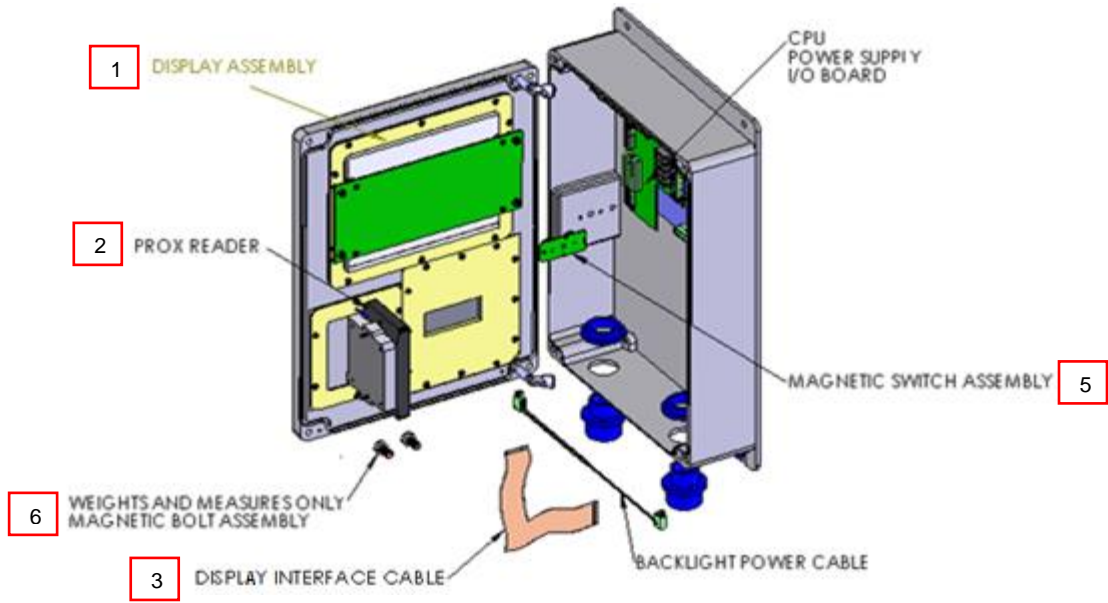


Figure 7.5 MultiLoad II/ RCU II Div2 Unit Assembly Prox Slotted Card Holder Mount

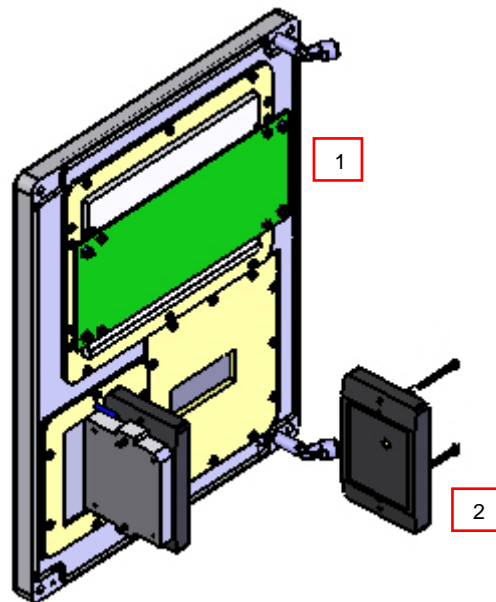


Figure 7.6 Exploded View Front Cover Assembly: Prox Slotted Card Holder Mount

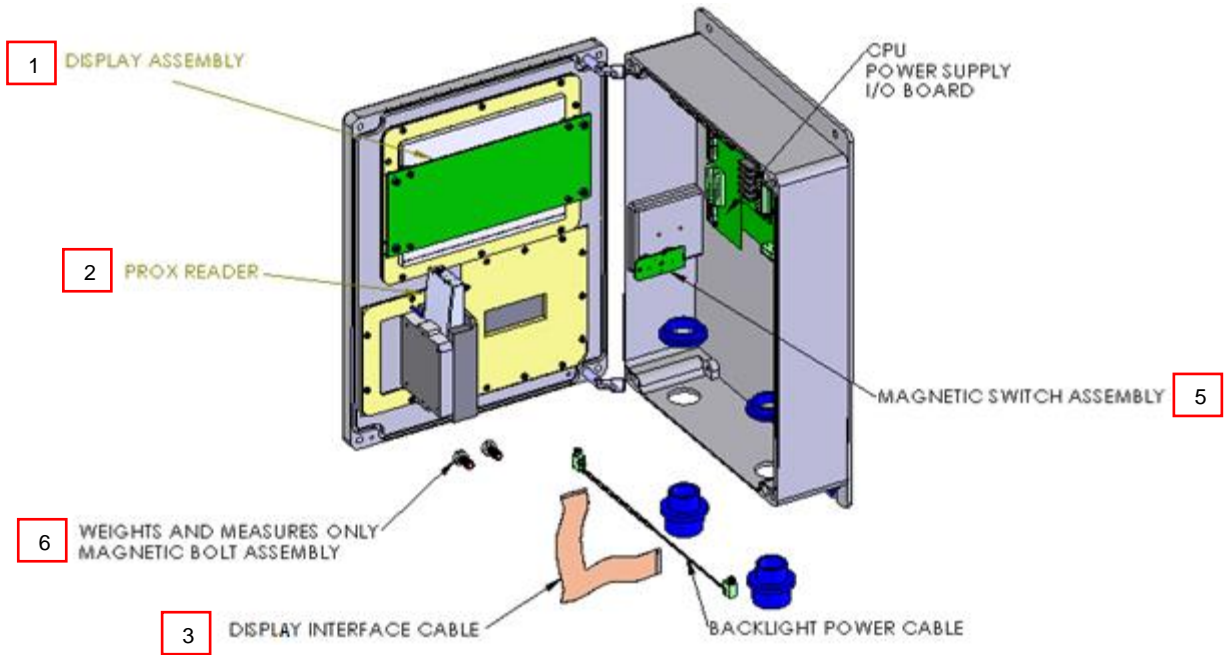


Figure 7.7 MultiLoad II/ RCU II Div2 Unit Assembly Prox Slotted Card Holder Mount: TWIC Reader

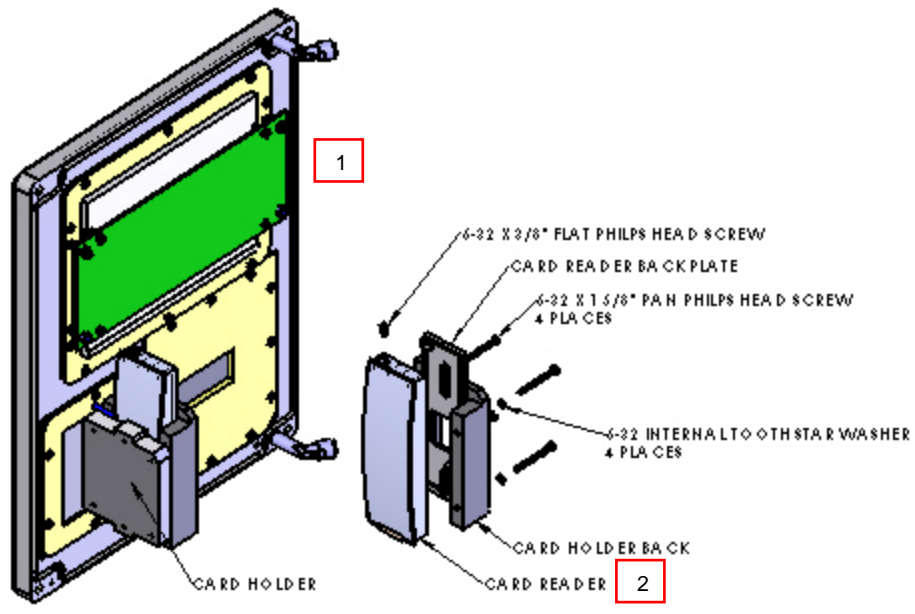
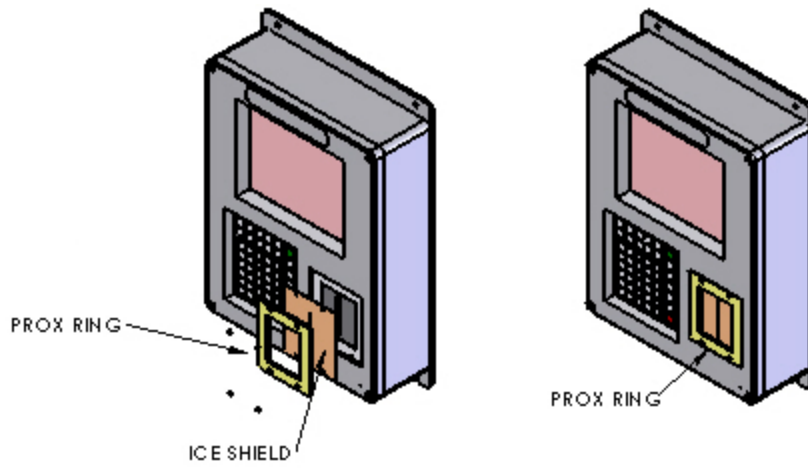
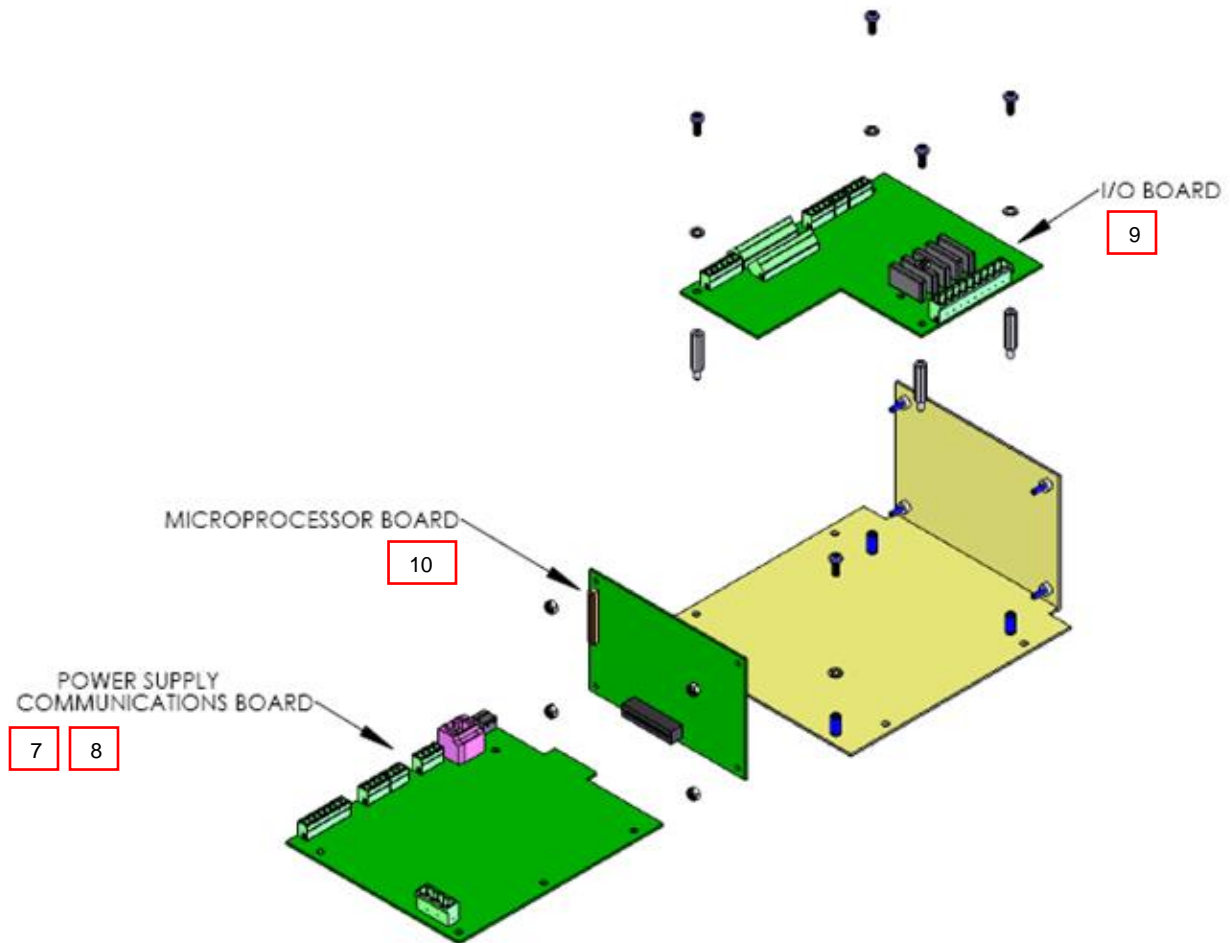


Figure 7.8 Exploded View Front Cover Assembly: Prox Slotted Card Holder Mount: TWIC Reader



**Figure 7.9 Ice Shield Assembly On Slotted Card Holder Mount:**



**Figure 7.10 Power Supply / Comm Board & I/O Board Chassis**

The Toptech replacement part numbers are shown in the table below.

<b>Part</b>	<b>Part Number</b>
DIV-2 Display Assembly (1)	4720
Prox Reader (2):	
Non Captive	4727
Captive	4726
TWIC Non Captive	2302
TWIC Captive	2303
DIV-2 Keypad (3)	1257
Magnetic Switch Assembly (4)	1900
Magnetic Bolt Assembly (5)	1901
Ice Shield (6)	2443

<b>Part</b>	<b>Part Number</b>
AC Power Supply Board (7):	
Revision 1.0	obsolete
Revision 1.1	4728
DC Power Supply Board (8):	
Revision 1.0	obsolete
Revision 1.1	4729
I/O Board (9):	
SCS I/O Board, Revision 1.0	2666
CPU Board (10):	
Revision 1.0	obsolete
Revision 2.0	4723

