

Micro Motion® Liquefied Natural Gas Meter

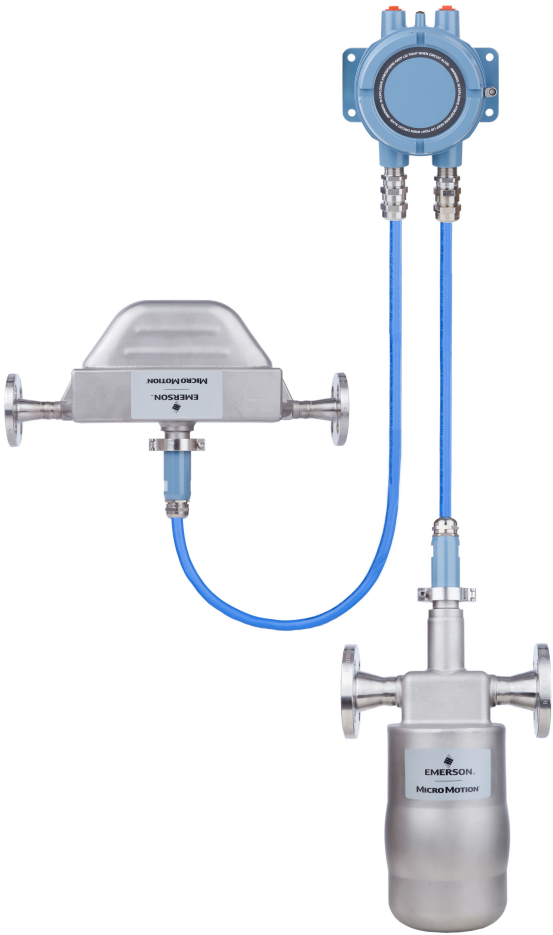

Other information

Full product specifications can be found in the product data sheet. Troubleshooting information can be found in the configuration manual. Product data sheets and manuals are available from the Micro Motion web site at www.emerson.com.

Return policy

Follow Micro Motion procedures when returning equipment. These procedures ensure legal compliance with government transportation agencies and help provide a safe working environment for Micro Motion employees. Micro Motion will not accept your returned equipment if you fail to follow Micro Motion procedures.

Return procedures and forms are available on our web support site at www.emerson.com, or by phoning the Micro Motion Customer Service department.

Emerson Flow customer service

Email:

- Worldwide: flow.support@emerson.com
- Asia-Pacific: APflow.support@emerson.com

Telephone:

North and South America		Europe and Middle East		Asia Pacific	
United States	800-522-6277	U.K.	0870 240 1978	Australia	800 158 727
Canada	+1 303-527-5200	The Netherlands	+31 (0) 704 136 666	New Zealand	099 128 804
Mexico	+41 (0) 41 7686 111	France	0800 917 901	India	800 440 1468
Argentina	+54 11 4837 7000	Germany	0800 182 5347	Pakistan	888 550 2682
Brazil	+55 15 3413 8000	Italy	8008 77334	China	+86 21 2892 9000
		Central & Eastern	+41 (0) 41 7686 111	Japan	+81 3 5769 6803
		Russia/CIS	+7 495 981 9811	South Korea	+82 2 3438 4600
		Egypt	0800 000 0015	Singapore	+65 6 777 8211
		Oman	800 70101	Thailand	001 800 441 6426
		Qatar	431 0044	Malaysia	800 814 008
		Kuwait	663 299 01		
		South Africa	800 991 390		
		Saudi Arabia	800 844 9564		
		UAE	800 0444 0684		

Contents

Chapter 1	Planning	1
1.1	Installation checklist	1
1.2	Best practices	2
1.3	Power requirements	2
Chapter 2	Architecture	4
2.1	LNG meters with dual core processor architecture	4
2.2	LNG meters with enhanced core processor architecture	5
Chapter 3	Mounting	6
3.1	Provide for maintenance accessibility	6
3.2	Mount the LNG sensors	6
3.3	Mount the dual core processor (option 1)	7
3.4	Mount the MVD Direct Connect I.S. barrier (option 2)	8
3.5	Mount the enhanced core processor (option 2)	9
Chapter 4	Transmitter power and I/O wiring	11
4.1	Prepare the cable between the host and core processor	11
4.2	Prepare the cable between the sensor and core processor	12
4.3	Wire the core processor to the sensor	14
4.4	Wire the dual core processor (option 1)	20
4.5	Wire the enhanced core processor (option 2)	23
Chapter 5	Grounding	26
5.1	Ground a dual core processor	26
5.2	Ground the enhanced core processor	27

1 Planning

Topics covered in this chapter:

- [Installation checklist](#)
- [Best practices](#)
- [Power requirements](#)

1.1 Installation checklist

- Make sure that the hazardous area specified on the approval tag is suitable for the environment in which the LNG meters will be installed.
- Verify that the local ambient and process temperatures are within the limits of the LNG meters.
- Verify that you are using low-voltage DC power for the core processor. Excess voltage can damage the core processor.
- For I.S. applications, refer to Micro Motion ATEX, UL, or CSA installation instructions.
- Mount the LNG electronics in any orientation as long as the conduit openings do not point upward.

⚠ CAUTION!

Upward-facing conduit openings risk condensation entering the housing that can damage the electronics.

- Install the sensors so that the flow direction arrow on the case matches the actual forward flow of the process. (Flow direction is also software-selectable.)

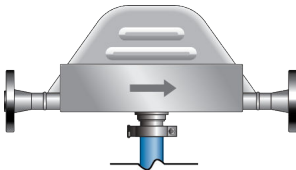
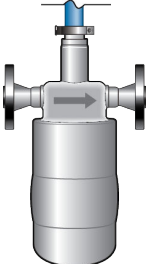
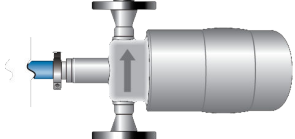
LNGS06 Gas return sensor	LNGM10 Filling sensor	
		

1.2 Best practices

The following information can help you get the most from your sensor.

- There are no pipe run requirements for Micro Motion sensors. Straight runs of pipe upstream or downstream are unnecessary.
- If the sensor is installed in a vertical pipeline, liquids and slurries should flow upward through the sensor. Gases should flow downward.
- Keep the sensor tubes full of process fluid.
- For halting flow through the sensor with a single valve, install the valve downstream from the sensor.
- Minimize bending and torsional stress on the sensor. Do not use the sensor to align misaligned piping.
- The sensor does not require external supports. The flanges will support the sensor in any orientation.

1.3 Power requirements

- 18 to 30 VDC, 3 watts typical, 5 watts maximum
- Minimum 28 VDC with 300 meters of 1 mm² power-supply cable
- At startup, power source must provide a minimum of 0.5 amperes of short term current at a minimum of 18 volts at the electrical parts power input terminals
- The maximum steady state current is 0.2A
- Complies with Installation (Overvoltage) Category II, Pollution Degree 2

Note

Length and conductor diameter of the power cable must be sized to provide 18 VDC minimum at the power terminals, at a load current of 0.2 amps.

Cable sizing formula

$$M = 18V + (R \times L \times 0.2A)$$

- M: minimum supply voltage
- R: cable resistance
- L: cable length

Table 1-1: Typical power cable resistance at 68 °F (20 °C)

Wire gauge	Resistance
14 AWG	0.0050 Ω/ft
16 AWG	0.0080 Ω/ft
18 AWG	0.0128 Ω/ft
20 AWG	0.0204 Ω/ft

Table 1-1: Typical power cable resistance at 68 °F (20 °C) (continued)

Wire gauge	Resistance
2.5 mm ²	0.0136 Ω/m
1.5 mm ²	0.0228 Ω/m
1.0 mm ²	0.0340 Ω/m
0.75 mm ²	0.0460 Ω/m
0.50 mm ²	0.0680 Ω/m

2 Architecture

Topics covered in this chapter:

- *LNG meters with dual core processor architecture*
- *LNG meters with enhanced core processor architecture*

2.1 LNG meters with dual core processor architecture

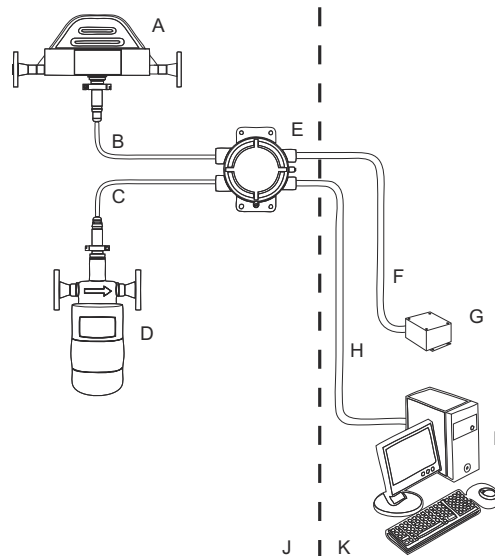

- A. *LNGS06 for returning measurement*
- B. *9-wire cable*
- C. *9-wire cable*
- D. *LNGM10 for filling measurement*
- E. *Dual core processor*
- F. *User-supplied power cable*
- G. *DC power supply*
- H. *User-supplied RS-485 cable*
- I. *Remote host*
- J. *Hazardous area*
- K. *Safe area*

2.2 LNG meters with enhanced core processor architecture

The following illustration describes the architecture for LNG meters with enhanced core processors and an MVD Direct Connect I.S. barrier.

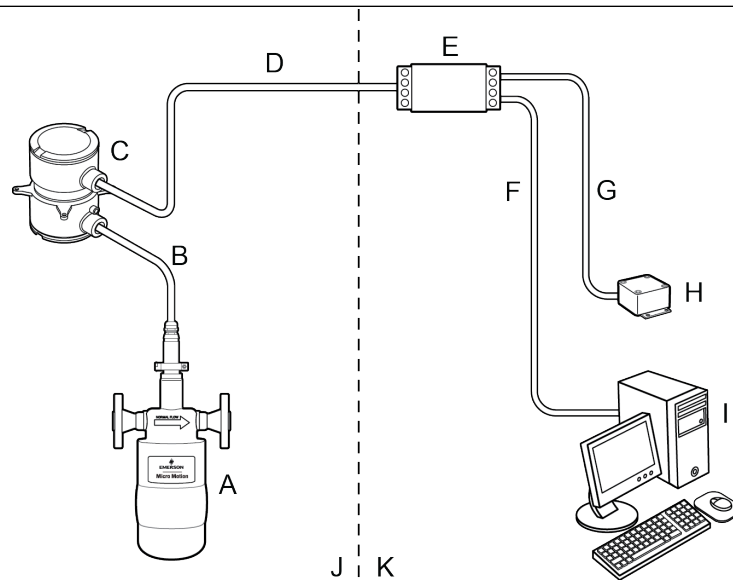

- A. LNM10 for filling measurement or LNS06 for gas return
- B. 9-wire cable
- C. Enhanced core processor
- D. 4-wire cable
- E. Barrier
- F. User-supplied RS-485 cable
- G. User-supplied power cable
- H. DC power supply
- I. Remote host
- J. Hazardous area
- K. Safe area

3 Mounting

Topics covered in this chapter:

- *Provide for maintenance accessibility*
- *Mount the LNG sensors*
- *Mount the dual core processor (option 1)*
- *Mount the MVD Direct Connect I.S. barrier (option 2)*
- *Mount the enhanced core processor (option 2)*

3.1 Provide for maintenance accessibility

Mount the electronics enclosure in a location and orientation that satisfies the following conditions:

- Allows sufficient clearance to open the enclosure cover. MicroMotion recommends 200–250 mm clearance at the rear of the electronics enclosure.
- Provides clear access for installing cabling to the enclosure.

3.2 Mount the LNG sensors

Use best practices to minimize torque and bending load on process connections.

⚠ CAUTION!

Do not lift the sensor by the electronics or cable as this can damage the device.

Procedure

1. Mount the gas return sensor (the LNGS06).

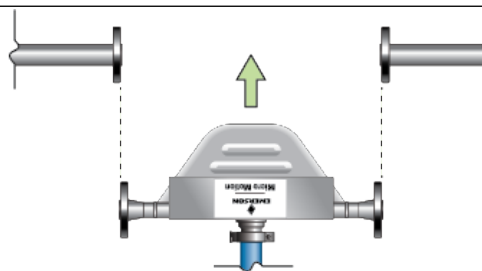

- *Do not use the sensor to support the piping.*
- *The sensor does not require external supports. The flanges will support the sensor in any orientation.*

2. Mount the filling sensor (the LNGM10).

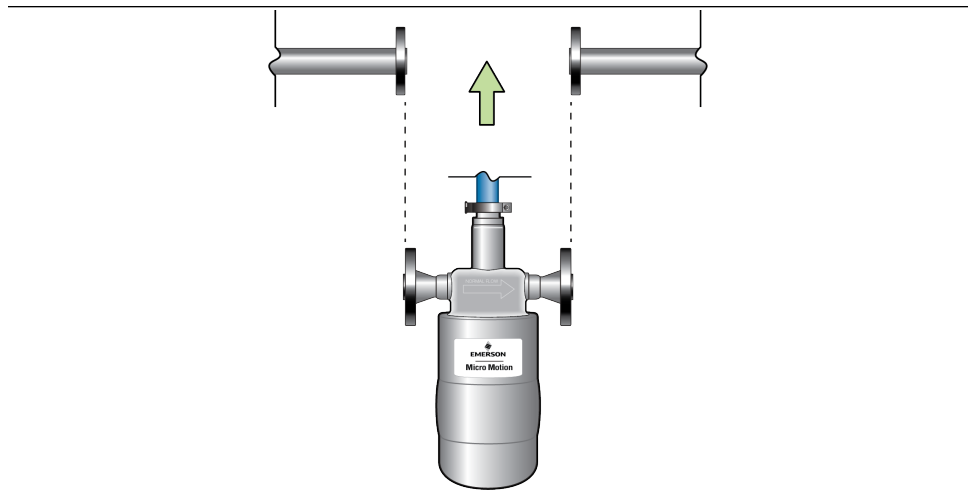

- Do not use the sensor to support the piping.
- The sensor does not require external supports. The flanges will support the sensor in any orientation.

3.3 Mount the dual core processor (option 1)

Attach the device to an instrument pole or wall. For a pipe mount, two user-supplied U-bolts are required. Contact Micro Motion to obtain a pipe-mount installation kit if required.

Figure 3-1: Pipe mount

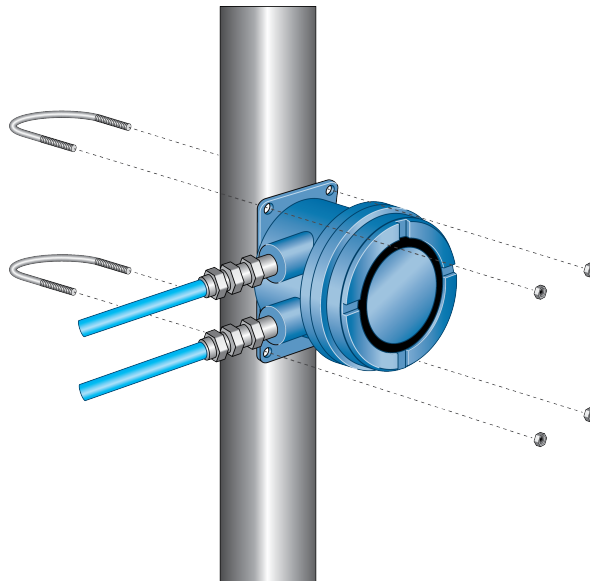
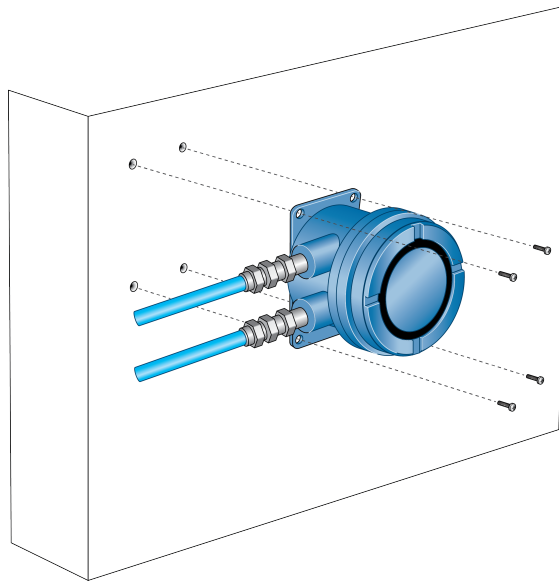
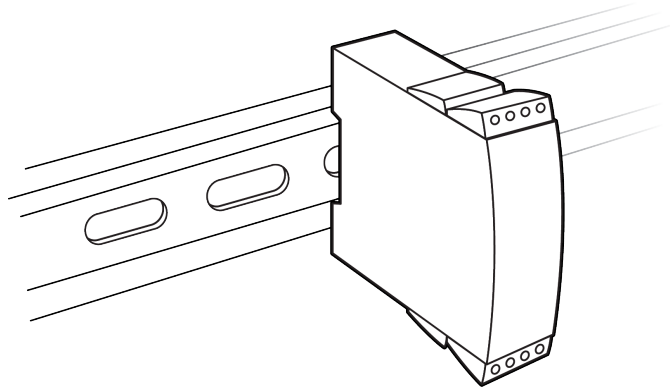

Figure 3-2: Wall mount



3.4 Mount the MVD Direct Connect I.S. barrier (option 2)

1. Snap the barrier onto a 35 mm DIN rail. You can mount it in either direction.
To remove the barrier from the rail, lift the bottom lock.
2. Hook one end of the end clamp over the DIN rail.
3. Position the end clamp snugly against the barrier.
4. Tighten the screw until the end clamp is securely fastened to the DIN rail.
5. Close the cover and fasten the clamps.
6. Attach the U-bolts to the mounting bracket.

Figure 3-3: Barrier mount on DIN rail

3.5 Mount the enhanced core processor (option 2)

1. If desired, reorient the core processor housing on the bracket.
 - a. Loosen each of the four cap screws.
 - b. Rotate the bracket so that the core processor is oriented as desired.
 - c. Tighten the cap screws, torquing to 3 to 4 N-m.
2. Attach the mounting bracket to an instrument pole or wall. For pipe mount, two user-supplied U-bolts are required. Contact Micro Motion to obtain a pipe-mount installation kit if required.

Figure 3-4: Enhanced core processor: pipe mount

Figure 3-5: Enhanced core processor: wall mount



4 Transmitter power and I/O wiring

Topics covered in this chapter:

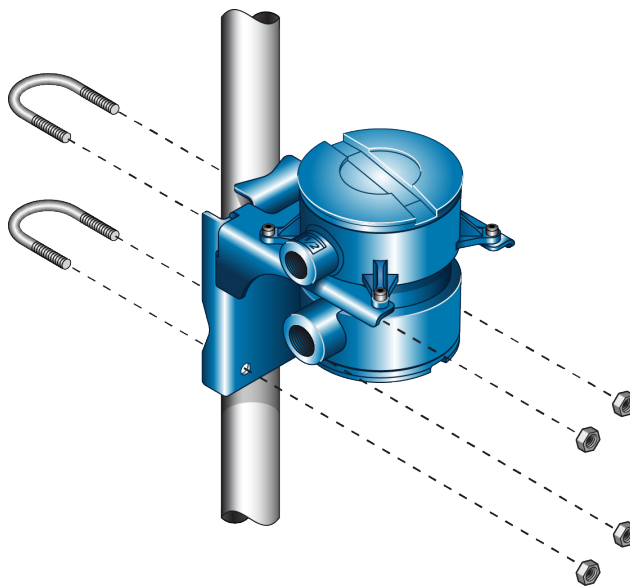
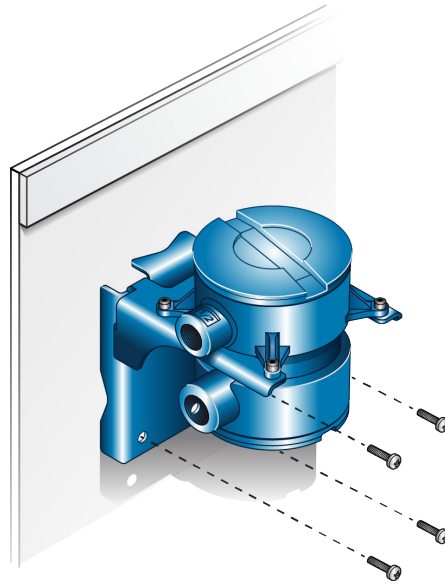
- *Prepare the cable between the host and core processor*
- *Prepare the cable between the sensor and core processor*
- *Wire the core processor to the sensor*
- *Wire the dual core processor (option 1)*
- *Wire the enhanced core processor (option 2)*

4.1 Prepare the cable between the host and core processor

4.1.1 Cable types and usage

Micro Motion offers two types of cable: shielded and armored. Both types contain shield drain wires.

The cable supplied by Micro Motion consists of one pair of red and black 18 AWG 0.75 mm² wires for the VDC connection, and one pair of white and green 22 AWG 0.35 mm² wires for the RS-485 connection.

User-supplied cable must meet the following requirements:

- Twisted pair construction.
- Applicable hazardous area requirements, if the core processor is installed in a hazardous area.
- Wire gauge appropriate for the cable length between the core processor and the transmitter, or the host.

Table 4-1: Wire gauge

Wire gauge	Maximum cable length
VDC 22 AWG (0.35 mm ²)	300 ft (90 m)
VDC 20 AWG (0.5 mm ²)	500 ft (150 m)
VDC 18 AWG (0.8 mm ²)	1000 ft (300 m)
RS-485 22 AWG (0.35 mm ²) or larger	1000 ft (300 m)

4.1.2 Prepare a cable with a metal conduit

1. Remove the core processor cover using a flat-blade screw driver.
2. Run the conduit to the sensor.

3. Pull the cable through the conduit.
4. Cut the drain wires and let them float at both ends of the conduit.

4.1.3 Prepare a cable with user-supplied cable glands

1. Remove the core processor cover using a flat-blade screw driver.
2. Pass the wires through the gland nut and gland body.

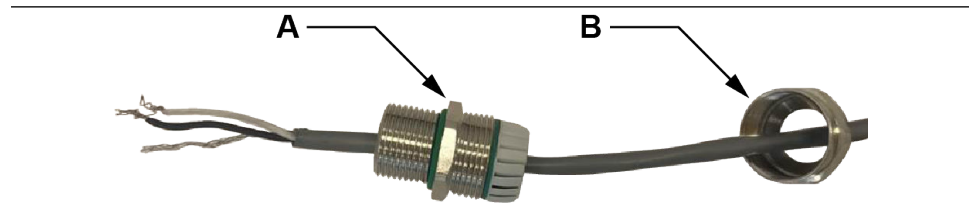

A. Gland body
B. Gland nut

3. Terminate the RS-485 shield and drain wires to the housing internal grounding screw.
4. Assemble the gland according to vendor instructions.

4.2 Prepare the cable between the sensor and core processor

Micro Motion supplies two types of 9-wire cable: jacketed and shielded. The type of cable you are using determines how you will prepare the cable.

Prepare the cable preparation procedure appropriate for your cable type.

4.2.1 9-Wire cable types and usage

Cable types

Micro Motion supplies two types of 9-wire cable: jacketed, and shielded. Note the following differences between the cable types:

- Jacketed cable has a smaller bend radius than shielded cable.
- If hazardous-area compliance is required, the different cable types have different installation requirements.

Cable bend radii

Table 4-2: Bend radii of jacketed cable

Jacket material	Outside diameter	Minimum bend radii	
		Static (no load) condition	Under dynamic load
PVC	0.415 inches (10 mm)	3-1/8 inches (80 mm)	6-1/4 inches (159 mm)

Table 4-3: Bend radii of shielded cable

Jacket material	Outside diameter	Minimum bend radii	
		Static (no load) condition	Under dynamic load
PVC	0.525 inches (14 mm)	4-1/4 inches (108 mm)	8-1/2 inches (216 mm)

Cable illustrations

Figure 4-1: Cross-section view of jacketed cable

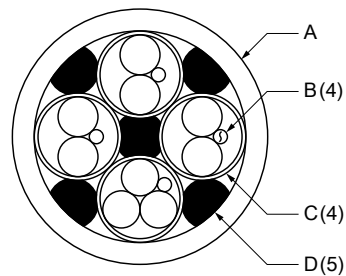

- A. Outer jacket
- B. Drain wire (4 total)
- C. Foil shield (4 total)
- D. Filler (5 total)

Figure 4-2: Cross-section view of shielded cable

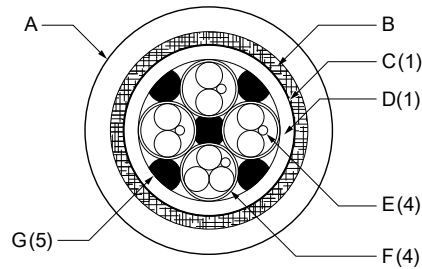

- A. Outer jacket
- B. Tin-plated copper braided shield
- C. Foil shield (1 total)
- D. Inner jacket
- E. Drain wire (4 total)
- F. Foil shield (4 total)
- G. Filler (5 total)

4.3 Wire the core processor to the sensor

4.3.1 Wire the core processor to the sensor using jacketed cable

Prerequisites

For hazardous area installations, install the jacketed cable inside a user-supplied sealed metallic conduit that provides 360° termination shielding for the enclosed cable.

⚠ CAUTION!

- **Sensor wiring is intrinsically safe. To keep sensor wiring intrinsically safe, keep the sensor wiring separated from power supply wiring and output wiring.**
- **Keep cable away from devices such as transformers, motors, and power lines, which produce large magnetic fields. Improper installation of cable, cable gland, or conduit could cause inaccurate measurements or flow meter failure.**
- **Improperly-sealed housings can expose electronics to moisture, which can cause measurement error or flowmeter failure. Install drip legs in conduit and cable, if necessary. Inspect and grease all gaskets and O-rings. Fully close and tighten all housing covers and conduit openings.**

Procedure

1. Run the cable through the conduit. Do not install 9-wire cable and power cable in the same conduit.

2. To prevent conduit connectors from seizing in the threads of the conduit openings, apply a conductive anti-galling compound to the threads, or wrap threads with PTFE tape two to three layers deep.

Wrap the tape in the opposite direction that the male threads will turn when inserted into the female conduit opening.

3. Remove the device cover.
4. At the core processor, do the following:
 - a. Connect a male conduit connector and waterproof seal to the conduit opening for 9-wire.
 - b. Pass the cable through the conduit opening for the 9-wire cable.
 - c. Insert the stripped end of each wire into the corresponding terminal at the core processor ends, matching by color. No bare wires should remain exposed. See [Table 4-4](#).

Table 4-4: Terminal designations

Wire color	Function
Black	Drain wires
Brown	Drive +
Red	Drive –
Orange	Temperature –
Yellow	Temperature return
Green	Left pickoff +
Blue	Right pickoff +
Violet	Temperature +
Gray	Right pickoff –
White	Left pickoff –

Figure 4-3: Dual core processor terminals

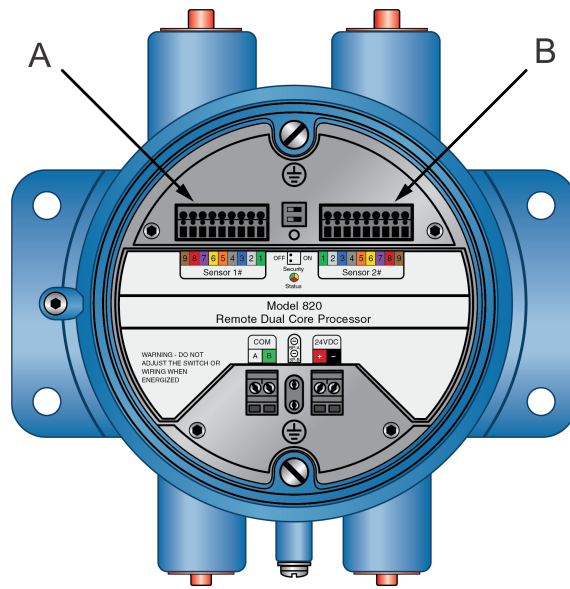

- A. Sensor 1
- B. Sensor 2

Figure 4-4: Enhanced core processor terminals

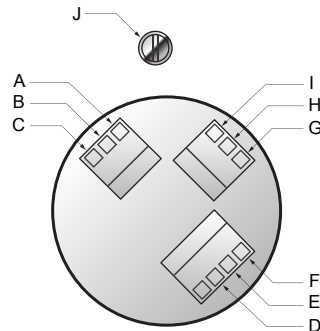

- A. Brown
- B. Violet
- C. Yellow
- D. Orange
- E. Gray
- F. Blue
- G. White
- H. Green
- I. Red
- J. Ground screw (black)

- d. Tighten the screws to hold the wire in place.
- e. Ensure integrity of gaskets, grease all O-rings, then replace the device housing cover and tighten all screws, as required.

4.3.2 Wire the core processor to the sensor using shielded cable

Prerequisites

For hazardous area installations, shielded cable must be installed with cable glands at the core processor end. Cable glands that meet hazardous area requirements can be purchased from Micro Motion. Cable glands from other vendors can be used.

⚠ CAUTION!

- **Sensor wiring is intrinsically safe. To keep sensor wiring intrinsically safe, keep the sensor wiring separated from power supply wiring and output wiring.**
- **Keep cable away from devices such as transformers, motors, and power lines, which produce large magnetic fields. Improper installation of cable, cable gland, or conduit could cause inaccurate measurements or flow meter failure.**
- **Improperly-sealed housings can expose electronics to moisture, which can cause measurement error or flowmeter failure. Install drip legs in conduit and cable, if necessary. Inspect and grease all gaskets and O-rings. Fully close and tighten all housing covers and conduit openings.**

Procedure

1. Identify the components of the cable gland and cable.

Figure 4-5: Cable gland and cable (exploded view)

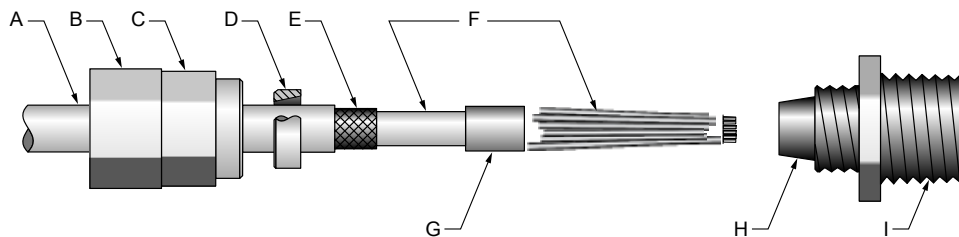

- A. Cable
- B. Sealing nut
- C. Compression nut
- D. Brass compression ring
- E. Braided shield
- F. Cable
- G. Tape or heat-shrink tubing
- H. Clamp seat (shown as integral to nipple)
- I. Nipple

2. Unscrew the nipple from the compression nut.
3. Screw the nipple into the conduit opening for the 9-wire cable. Tighten it to one turn past hand-tight.
4. Slide the compression ring, compression nut, and sealing nut onto the cable. Make sure the compression ring is oriented so the taper will mate properly with the tapered end of the nipple.
5. Pass the cable end through the nipple so the braided shield slides over the tapered end of the nipple.
6. Slide the compression ring over the braided shield.
7. Screw the compression nut onto the nipple. Tighten the sealing nut and compression nut by hand to ensure that the compression ring traps the braided shield.
8. Use a 25-mm (1-inch) wrench to tighten the sealing nut and compression nut to 20–25 foot-pounds (27–34 N-m) of torque.

Figure 4-6: Cross-section of assembled cable gland with cable

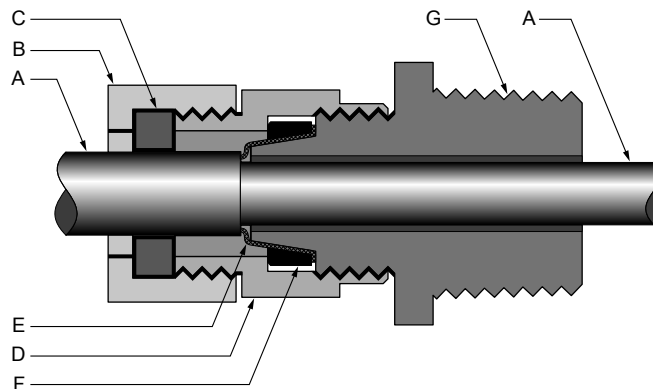

- A. Cable
- B. Sealing nut
- C. Seal
- D. Compression nut
- E. Braided shield
- F. Brass compression ring
- G. Nipple

9. Remove the device cover.
10. At the core processor, connect the cable according to the following procedure:
 - a. Insert the stripped end of each wire into the corresponding terminal at the core processor ends, matching by color. No bare wires should remain exposed. See the following table.

Table 4-5: Terminal designations

Wire color	Function
Black	Drain wires
Brown	Drive +
Red	Drive -
Orange	Temperature -
Yellow	Temperature return
Green	Left pickoff +
Blue	Right pickoff +
Violet	Temperature +
Gray	Right pickoff -
White	Left pickoff -

Figure 4-7: Dual core processor terminals

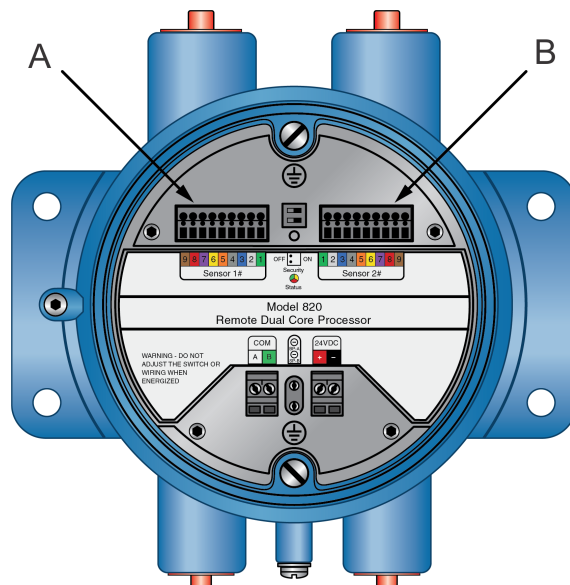

- A. Sensor 1
- B. Sensor 2

Figure 4-8: Enhanced core processor terminals

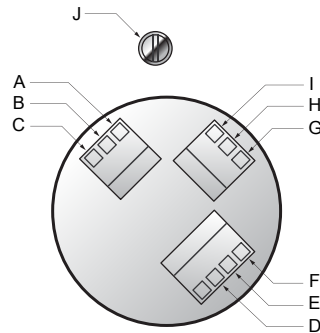

- A. *Brown*
- B. *Violet*
- C. *Yellow*
- D. *Orange*
- E. *Gray*
- F. *Blue*
- G. *White*
- H. *Green*
- I. *Red*
- J. *Ground screw (black)*

- b. Tighten the screws to hold the wires in place.
- c. Ensure integrity of gaskets, grease all O-rings, then replace the device housing cover and tighten all screws, as required.

4.4 Wire the dual core processor (option 1)

Use this section for a dual core processor installation.

4.4.1 Connect the 9-wire cable on a dual core processor

Prerequisites

Prepare and install the cable according to the instructions in this document.

Procedure

1. Remove the dual processor housing cover.
2. Insert the stripped ends of the individual wires into the terminal blocks. Ensure that no bare wires remain exposed.
3. Match the wires color for color.

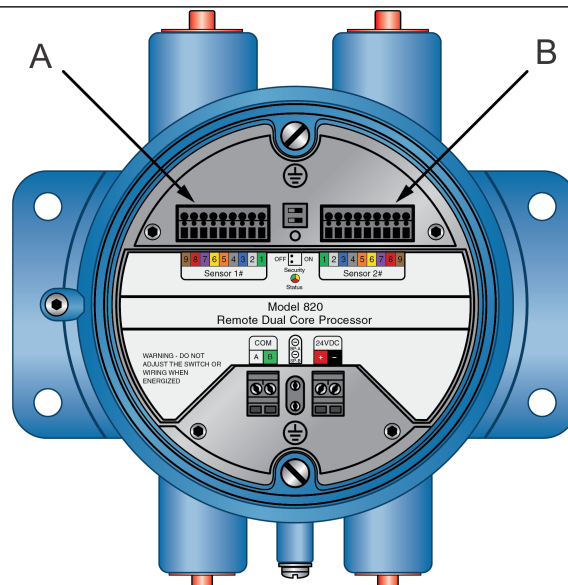

- A. Sensor 1
B. Sensor 2

4. If the wire length is not 3m, use ProLink III to register a different length. For more information, see the *Micro Motion LNG Series Meters Configuration and Use Manual*.

4.4.2 Wire the dual core processor power supply

Prerequisites

Prepare and install the cable according to the instructions in this document.

Procedure

Connect the power supply wires to the positive (+) and negative (-) terminals.

Terminate the positive (line) wire on the positive (+) red terminal and the return (neutral) wire on the negative (-) black terminal.

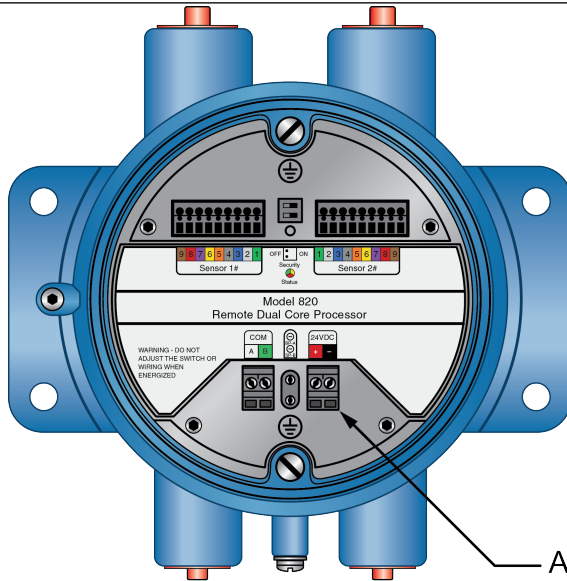

A. Power supply

4.4.3 Wire the dual core processor outputs

Prerequisites

Prepare and install the cable according to the instructions in this document.

Procedure

Connect the RS-485 wires to the white RS485A and green RS485B connectors.

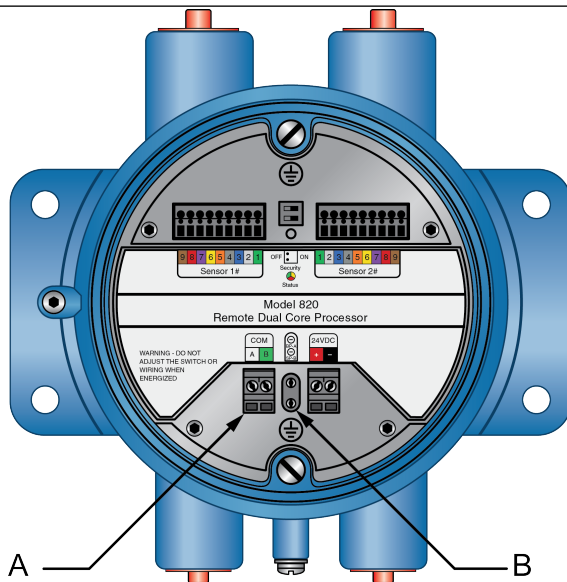

A. RS-485
B. Service port

4.5 Wire the enhanced core processor (option 2)

Use this section for an enhanced core processor installation.

4.5.1 Connect the 9-wire cable on a remote enhanced core processor

Prerequisites

Prepare and install the cable according to the instructions in this document.

Procedure

1. Insert the stripped ends of the individual wires into the terminal blocks. Ensure that no bare wires remain exposed.
2. Match the wires color for color.
3. Tighten the screws to hold the wires in place.
4. Ensure integrity of gaskets, then tightly close and seal all housing covers.

4.5.2 Wire the MVD Direct Connect I.S. barrier

Prerequisites

Prepare and install the cable according to the instructions in this document.

Procedure

Connect the enhanced core processor to the barrier:

- a. Connect the RS-485 wires from the enhanced core processor to the I.S. RS-485 terminals at the barrier (terminals 43 and 44), matching A and B. See the following table and figure.
- b. Connect the power supply wires from the core processor to the I.S. VDC terminals at the barrier (terminals 42 and 41), matching positive and negative (+ and –). Do not terminate the shields at the barrier. See the following table and figure.

Table 4-6: Enhanced core processor and barrier I.S. terminals

Function	Core processor terminals	Barrier I.S. terminals
RS-485 A	3	43
RS-485 B	4	44
VDC +	1	42
VDC –	2	41

- c. Connect the RS-485 wires to the non-I.S. RS-485 terminals at the barrier (terminals 13 and 14). These wires will be used in the next step to connect the barrier to the remote host. Do not terminate the shields at the barrier.

- d. Connect the power supply wires to the non-I.S. VDC terminals at the barrier (terminals 11 and 12). These wires will be used in the next step to connect the barrier to the power supply.

Figure 4-9: Barrier terminals

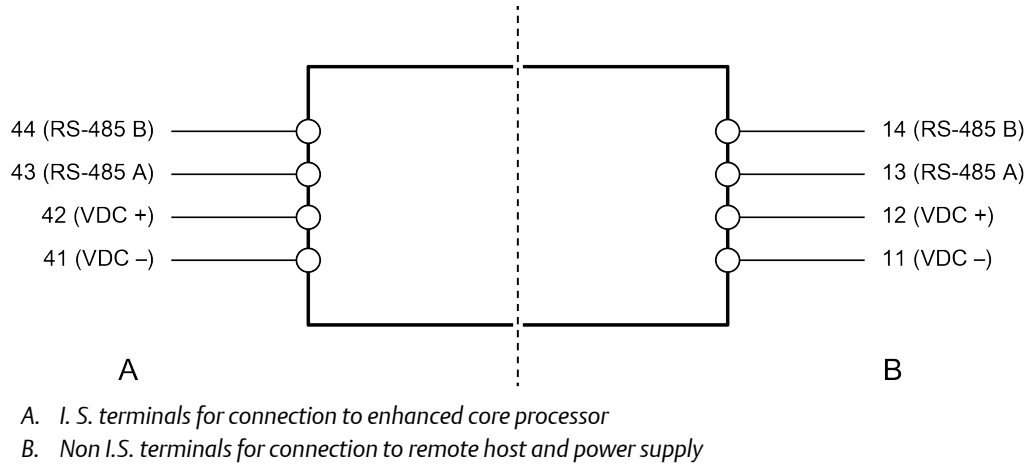

4.5.3 Wire the power supply to the MVD Direct Connect I.S. barrier

- You can connect multiple MVD Direct Connect installations to a single power supply, as long as each installation receives sufficient power.
- For power supply to I.S. barrier connections, the power supply can be used to power other equipment.

Procedure

Connect the power supply wires from the barrier, matching positive and negative (+ and -).

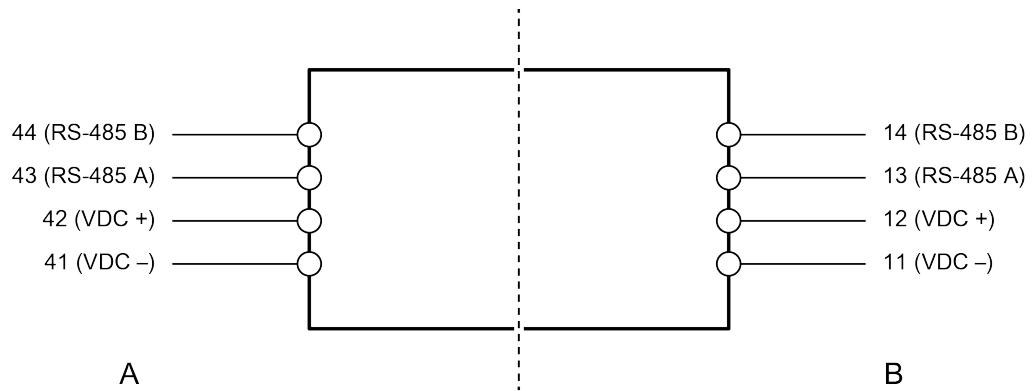
Figure 4-10: Barrier terminals

A. I.S. terminals for connection to enhanced core processor

B. Non I.S. terminals for connection to remote host and power supply

4.5.4 Wire the remote host to the MVD Direct Connect I.S. Barrier

1. Connect the RS-485 wire from the barrier to the RS-485 terminals at the remote host.

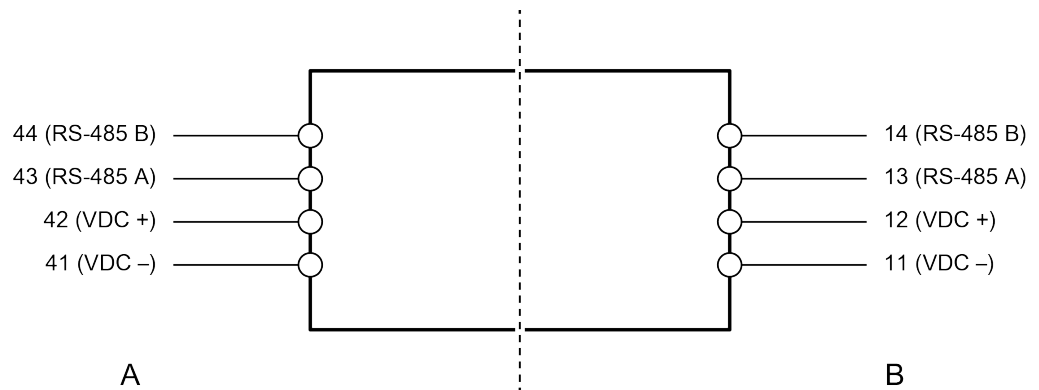
Figure 4-11: Barrier terminals

A. I.S. terminals for connection to enhanced core processor

B. Non I.S. terminals for connection to remote host and power supply

2. Terminate the shields at the remote host.

Do not add external resistors. The barrier contains internal pull-up/pull-down and termination resistors.

5 Grounding

Topics covered in this chapter:

- *Ground a dual core processor*
- *Ground the enhanced core processor*

The meter must be grounded according to the standards that are applicable at the site. The customer is responsible for knowing and complying with all applicable standards.

Micro Motion suggests the following guides for grounding practices:

- Use copper wire, 2,0 mm² or larger wire size.
- Keep all ground leads as short as possible, less than 1 Ω impedance.
- Connect ground leads directly to earth, or follow plant standards.

5.1 Ground a dual core processor

Use this procedure if your installation contains a dual core processor.

Note

Ground the processor to earth, or follow ground network requirements for the facility. Improper grounding can cause measurement error.

Procedure

Check the joints in the pipeline.

- If the joints in the pipeline are ground-bonded, the meter is automatically grounded and no further action is necessary (unless required by local code).
- If the joints in the pipeline are not grounded, connect a ground wire to the internal or external grounding screw located on the dual core processor.

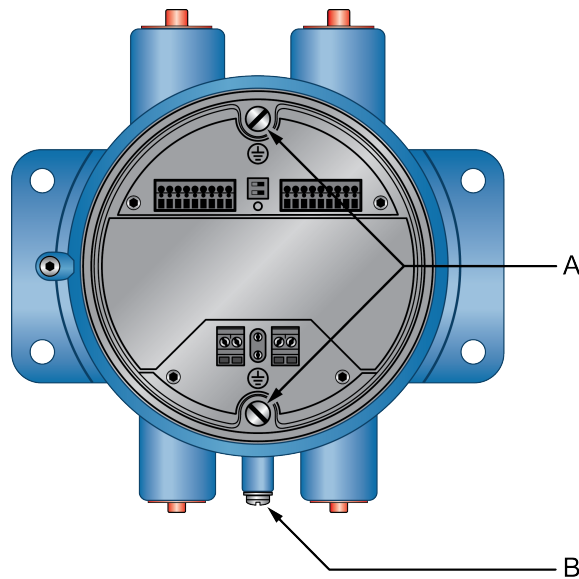
Figure 5-1: Dual core processor grounding screws

- A. *Internal grounding screws*
B. *External grounding screw*
-

5.2 Ground the enhanced core processor

Use this procedure if your installation contains an enhanced core processor.

Note

Ground the processor to earth, or follow ground network requirements for the facility. Improper grounding can cause measurement error.

Procedure

Check the joints in the pipeline.

- If the joints in the pipeline are ground-bonded, the meter is automatically grounded and no further action is necessary (unless required by local code).
- If the joints in the pipeline are not grounded, connect a ground wire to the internal or external grounding screw located on the enhanced core processor.

Figure 5-2: Enhanced core processor grounding screws

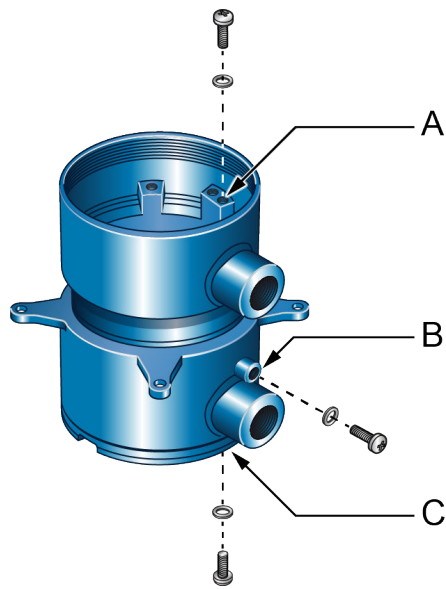

- A. *Internal ground screw*
- B. *External ground screw*
- C. *Internal ground screw*



MMI-20032351

Rev AB

2017

Micro Motion Inc. USA

Worldwide Headquarters
7070 Winchester Circle
Boulder, Colorado USA 80301
T +1 303-527-5200
T +1 800-522-6277
F +1 303-530-8459
www.emerson.com

Micro Motion Europe

Emerson Automation Solutions
Neonstraat 1
6718 WX Ede
The Netherlands
T +31 (0) 70 413 6666
F +31 (0) 318 495 556
www.micromotion.nl

Micro Motion Asia

Emerson Automation Solutions
1 Pandan Crescent
Singapore 128461
Republic of Singapore
T +65 6777-8211
F +65 6770-8003

Micro Motion United Kingdom

Emerson Automation Solutions
Emerson Process Management Limited
Horsfield Way
Bredbury Industrial Estate
Stockport SK6 2SU U.K.
T +44 0870 240 1978
F +44 0800 966 181

Micro Motion Japan

Emerson Automation Solutions
1-2-5, Higashi Shinagawa
Shinagawa-ku
Tokyo 140-0002 Japan
T +81 3 5769-6803
F +81 3 5769-6844

©2017 Micro Motion, Inc. All rights reserved.

The Emerson logo is a trademark and service mark of Emerson Electric Co. Micro Motion, ELITE, ProLink, MVD and MVD Direct Connect marks are marks of one of the Emerson Automation Solutions family of companies. All other marks are property of their respective owners.

MICRO MOTION™

