

Micro Motion[®] EtherNet/IP Module

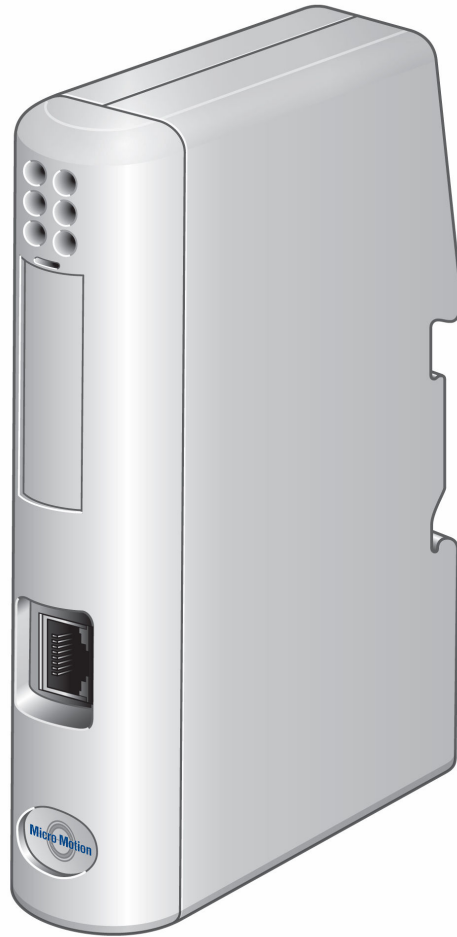

Safety messages

Safety messages are provided throughout this manual to protect personnel and equipment. Read each safety message carefully before proceeding to the next step.

Other information

Full product specifications can be found in the product data sheet. Troubleshooting information can be found in the configuration manual. Product data sheets and manuals are available from the Micro Motion web site at www.emerson.com.

Return policy

Follow Micro Motion procedures when returning equipment. These procedures ensure legal compliance with government transportation agencies and help provide a safe working environment for Micro Motion employees. Micro Motion will not accept your returned equipment if you fail to follow Micro Motion procedures.

Return procedures and forms are available on our web support site at www.emerson.com, or by phoning the Micro Motion Customer Service department.

Emerson Flow customer service

Email:

- Worldwide: flow.support@emerson.com
- Asia-Pacific: APflow.support@emerson.com

Telephone:

North and South America		Europe and Middle East		Asia Pacific	
United States	800-522-6277	U.K.	0870 240 1978	Australia	800 158 727
Canada	+1 303-527-5200	The Netherlands	+31 (0) 704 136 666	New Zealand	099 128 804
Mexico	+41 (0) 41 7686 111	France	0800 917 901	India	800 440 1468
Argentina	+54 11 4837 7000	Germany	0800 182 5347	Pakistan	888 550 2682
Brazil	+55 15 3413 8000	Italy	8008 77334	China	+86 21 2892 9000
		Central & Eastern	+41 (0) 41 7686 111	Japan	+81 3 5769 6803
		Russia/CIS	+7 495 981 9811	South Korea	+82 2 3438 4600
		Egypt	0800 000 0015	Singapore	+65 6 777 8211
		Oman	800 70101	Thailand	001 800 441 6426
		Qatar	431 0044	Malaysia	800 814 008
		Kuwait	663 299 01		
		South Africa	800 991 390		
		Saudi Arabia	800 844 9564		
		UAE	800 0444 0684		

Contents

Chapter 1	Before you begin.....	5
	1.1 About this document.....	5
	1.2 Related documentation.....	5
	1.3 Functional overview.....	5
	1.4 External view of device.....	7
	1.5 Default web pages.....	7
	1.6 Alternative web pages.....	7
Chapter 2	Installation.....	9
	2.1 Components.....	9
	2.2 Set up the module with MVD Direct Connect.....	9
	2.3 Set up the transmitter	10
	2.4 Mount, wire, and set the network settings.....	10
	2.5 Micro Motion Ethernet Config Tool installation (optional).....	13
	2.6 Configure the EtherNet/IP Module.....	14
Chapter 3	Basic network configuration.....	15
	3.1 TCP/IP settings.....	15
	3.2 Modbus serial network settings.....	17
Chapter 4	Emerson web server.....	19
	4.1 Web server access information.....	19
	4.2 Emerson EtherNet/IP Module web pages.....	19
Chapter 5	Integrate with Rockwell programming software.....	21
	5.1 Integrate with Rockwell versions 20 or later.....	21
	5.2 Integrate with Rockwell versions 19 or earlier.....	22
Chapter 6	Troubleshooting.....	27
	6.1 LED indicators.....	27
	6.2 Common problems.....	28
Appendix A	Connector pin assignments.....	31
	A.1 Ethernet connector.....	31
	A.2 Power connector.....	31
	A.3 Micro Motion Ethernet Config Tool installation (optional).....	31
	A.4 Modbus serial network interface.....	32
	A.5 Typical connection.....	34
Appendix B	Device profile.....	35
	B.1 Object classes.....	35
	B.2 Object details.....	35

B.3 I/O data.....	44
B.4 Get and Set services.....	56
B.5 Data types.....	57
B.6 Codes and integer values.....	58
B.7 Status words.....	66
Appendix C Specifications.....	73

1 Before you begin

1.1 About this document

This manual contains information required to install, configure, and use the EtherNet/IP Module. The EtherNet/IP Module enables integration of industrial devices into the Ethernet network with no loss of functionality, control, or reliability. The EtherNet/IP Module can be used for new or retrofit installations.

The Micro Motion EtherNet/IP Module is a customization of the Anybus Communicator from HMS Industrial Networks. OEM features not documented here are documented in the *Anybus Communicator User Manual* available on the HMS web site.

The information in this document assumes that users understand:

- Basic transmitter and sensor installation, configuration, and maintenance concepts and procedures
- All corporate, local government, and national government safety standards and requirements that guard against injuries and death

1.2 Related documentation

See any of the following documents for more information:

- *Anybus Communicator User Manual* on the HMS web site
- The sensor installation manual
- The transmitter installation manual
- The transmitter configuration and use manual

1.3 Functional overview

The EtherNet/IP Module acts as a gateway between the serial output of a Micro Motion device and an EtherNet/IP network. Using a web browser, the module supports:

- Process monitoring and control
- Configuration
- Administration

The EtherNet/IP Module consists of a Modbus master and an Ethernet slave.

- On the Modbus side, the module polls the transmitter for a standard set of process variables and stores the data locally.
- On the Ethernet side, the module receives requests for data and responds with the current values.
- The web browser is used for transmitter configuration and administration, via a connection to the Micro Motion web pages on the EtherNet/IP Module.
- The configuration loop is used only by the MicroMotion Ethernet Config Tool. In typical installations, this tool is not needed.

Figure 1-1: EtherNet/IP Module with a Model 2700 transmitter

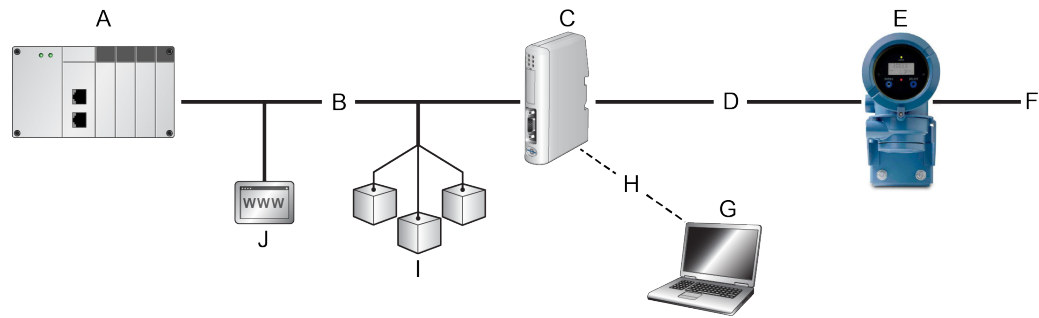

- A. PLC
- B. Ethernet
- C. EtherNet/IP Module
- D. Modbus/RS-485
- E. Transmitter (see Product Data Sheet for compatible transmitters)
- F. To sensor
- G. PC with Micro Motion Ethernet Config Tool
- H. Configuration loop (with configuration cable)
- I. Other devices (SCADA, PC, Inverter)
- J. Web browser

Figure 1-2: EtherNet/IP Module in an MVD Direct Connect installation

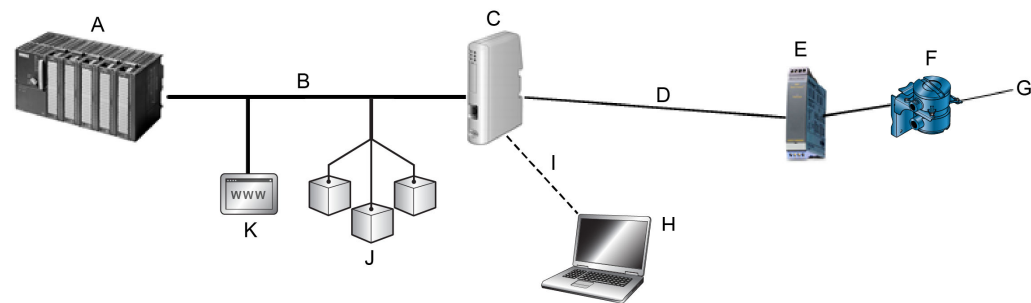

- A. PLC
- B. Ethernet
- C. EtherNet/IP Module
- D. Modbus/RS-485
- E. Barrier
- F. Core processor
- G. To sensor
- H. PC with Micro Motion Ethernet Config Tool
- I. Configuration loop (with configuration cable)
- J. Other devices (SCADA, PC, Inverter)
- K. Web browser

1.4 External view of device

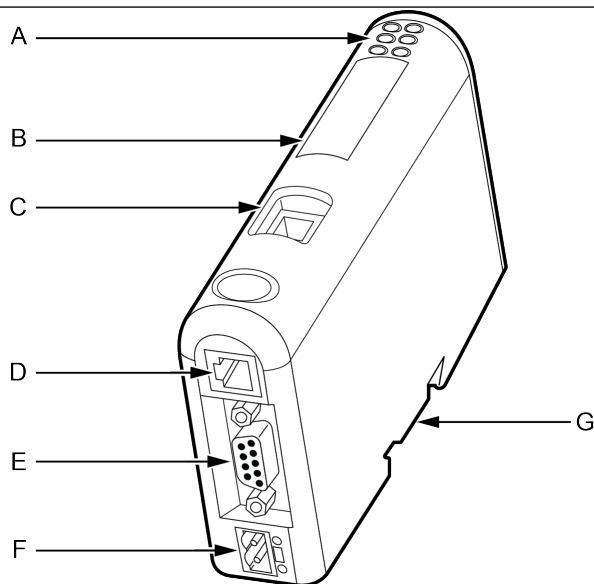

- A. Ethernet connector
- B. Configuration switches
- C. Status LEDs
- D. PC connector (configuration)
- E. Modbus serial connector (transmitter)
- F. Power connector
- G. DIN rail connector

1.5 Default web pages

The EtherNet/IP Module is preloaded with the Emerson standard web pages. These web pages allow the user to view process data and alerts, to configure the most commonly used parameters on the transmitter, to perform maintenance procedures, and to download support files from the device.

1.6 Alternative web pages

To support the petroleum measurement or concentration measurement application, Micro Motion supplies alternate sets of web pages and configuration files. These are available for download from the Emerson web site.

2 Installation

2.1 Components

Ensure that you have all required components:

- Micro Motion EtherNet/IP Module
- Power connector
- Micro Motion EtherNet/IP Resource CD
 - *Micro Motion EtherNet/IP Module User Manual*
 - EDS file
 - MicroMotion Ethernet Config Tool
- Configuration cable
- Modbus serial cable and connector (included)
- Ethernet cable and connector (not included)

2.2 Set up the module with MVD Direct Connect

Use this procedure only if you are installing the module with MVD Direct Connect.

Procedure

1. Mount and wire the core processor and barrier.

Figure 2-1: Barrier

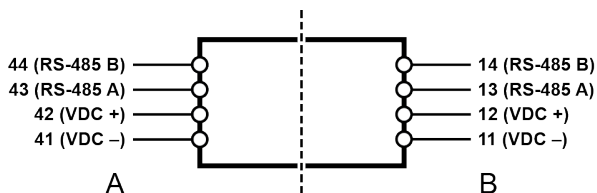

A. I.S. terminals for connection to core processor

B. Non-I.S. terminals for connection to remote host and power supply

2. Power up the core processor and barrier.
3. Set the Modbus address on the core processor to 1.

Postrequisites

Continue to [Mount, wire, and set the network settings.](#)

2.3 Set up the transmitter

Use this procedure only if you are installing the module with a transmitter.

Procedure

1. Mount the transmitter and wire it to the sensor and to power.
2. Power up the transmitter.
3. Set the Modbus address on the transmitter to 1.
4. If your transmitter does not support Modbus auto-detect, configure the RS-485 terminals as follows:
 - Modbus RTU
 - 38400 baud
 - 2 stop bits
 - No parity

Postrequisites

Continue to [Mount, wire, and set the network settings](#).

2.4 Mount, wire, and set the network settings

Use this procedure to mount, wire, and set the network settings for both the transmitter and MVD Direct Connect configurations.

Procedure

1. Ensure that the following slot registers are available for use by the EtherNet/IP Module:
 - 655–750
 - 751–846If these slot registers are currently in use, you must reprogram your Modbus interface.
2. Mount the EtherNet/IP Module on the DIN rail.

Figure 2-2: Snap on

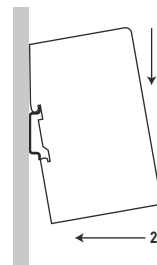
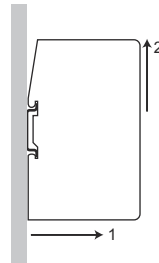
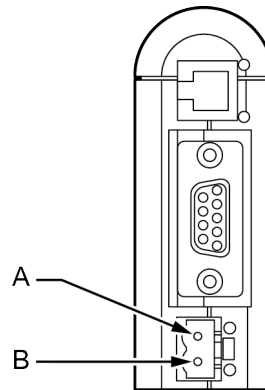

Figure 2-3: Snap off



3. Wire the EtherNet/IP Module to power (24 VDC).

Figure 2-4: Power connections on the EtherNet/IP module



- A. 24 VDC
- B. Ground

4. Install the Modbus serial cable between the EtherNet/IP Module and the RS-485 terminals on the transmitter (or the I.S. barrier, if present).

Figure 2-5: Modbus serial connector on the EtherNet/IP module

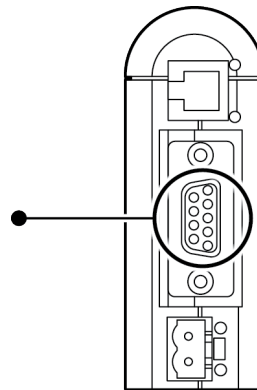

See [Modbus terminals](#) and [Pin assignments \(EtherNet/IP Module\)](#).

5. Set the configuration dip switches on the EtherNet/IP module as follows:

- Switches 1–7: Off
- Switch 8: On

The IP address is set to 192.168.0.1.

6. If you are using a Model 1500, Model 2500, or Series 3000 transmitter, ensure that the RS-485 terminals are in RS-485 mode.
7. Cycle power to the transmitter and wait 15 seconds before applying power to the EtherNet/IP Module.
8. Power up the EtherNet/IP Module.
The module will attempt to make a Modbus connection to the transmitter.
9. Is the Subnet Status LED (LED 5) green?

Option	Description
Yes	Continue with these steps.
No	See LED indicators .

10. Set the network settings for the EtherNet/IP Module.
 - a) Change the Ethernet address setting for your PC so that it is on the same subnet as the device. When prompted, enter the following:
 - IP address: 192.168.0.x, where x is something other than 1
 - Subnet mask: 255.255.255.0
 - b) Disable the popup blocker on your web browser.
 - c) Use a crossover cable (or a standard cable with a switch) and your web browser to connect to the device, using the IP address assigned in Step 6: 192.168.0.1.
 - d) At the login screen, log in as user admin. The default password is admin. Ignore the auto-configuration popup window.
 - e) On the Network Settings page, change the settings as required, and close the web browser.
 - f) At the EtherNet/IP Module, set all dip switches to Off.
 - g) Cycle power to the EtherNet/IP Module.
11. Connect the EtherNet/IP Module to the Ethernet network.
See [Ethernet connector](#).
12. Wait for the auto-configuration process to complete.

Important

For initial startup, you must use the auto-configuration process to ensure that device memory is completely set up.

13. Add the EtherNet/IP Module to the Ethernet network control system. The EDS file is available on the Resource CD, the EtherNet/IP Module (download from Administration page), and the Emerson web site.

Postrequisites

For more information on transmitter installation and wiring, see your transmitter installation manual. For information on configuring the RS-485 terminals and making an RS-485 connection, see your transmitter configuration manual.

2.4.1 Modbus terminals

Transmitter	RS-485/A	RS-485/B
Model 1500	33	34
Model 1700 with analog outputs	5	6
Model 2500	33	34
Model 2700 with analog outputs	5	6
Model 3500 with screw-type or solder-tail terminals	32a	32b
Model 3500 with I/O cables	25	24
Model 3700	12	11

2.5 Micro Motion Ethernet Config Tool installation (optional)

Related tasks

[Install the Ethernet Config Tool](#)

2.5.1 Ethernet Config Tool system requirements

- Pentium 133 MHz or higher
- 10 MB of free space
- 8 MB RAM
- Windows NT v4.0 or higher, Windows 2000, or Windows XP
- Internet Explorer v4.01 SP1 or higher

2.5.2 Install the Ethernet Config Tool

Procedure

1. Install the software program. Locate and run the EtherNet/IP Module setup program on the EtherNet/IP Module Resource CD and follow the on-screen instructions.
2. Connect the configuration cable from your PC to the EtherNet/IP Module.

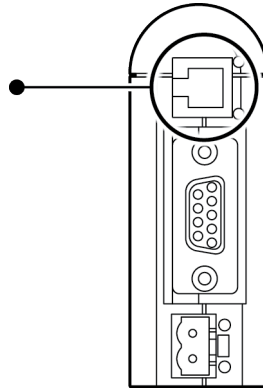

Note

For information on the Micro Motion Ethernet Config Tool user interface, see the Anybus Communicator manual.

Related concepts

[Micro Motion Ethernet Config Tool installation \(optional\)](#)

2.6 Configure the EtherNet/IP Module

Procedure

1. From your browser, login to the EtherNet/IP Module as user admin.
2.  **CAUTION**
Wait for the web pages to automatically configure the EtherNet/IP Module.

Use the **Device Configuration** page to configure the EtherNet/IP Module.
3. Set up I/O at your Ethernet host.
 - If you are not using RSLogix, use your standard method. For information on the I/O assemblies, see [I/O data](#).
 - If you are using RSLogix, select **ETHERNET-MODULE - Generic Ethernet Module** and enter the required information.

3 Basic network configuration

3.1 TCP/IP settings

To participate on the Ethernet network, the EtherNet/IP Module needs a valid TCP/IP configuration.

The EtherNet/IP Module can retrieve the TCP/IP settings from a DHCP or BootP server. If no such server is found, the EtherNet/IP Module uses the settings from the system file `\ethcfg.cfg`. If this file is not found, or the settings are invalid, the EtherNet/IP Module will halt and report an error on the status LED. However, the network configuration may still be accessed via the Ethernet Config Tool.

You can define the TCP/IP settings for the EtherNet/IP Module in the following ways:

- Micro Motion Network Configuration web page (recommended)
- Configuration switches on the device
- Ethernet Config Tool
- System file `\ethcfg.cfg` on the device

3.1.1 Micro Motion web page for network configuration

The **Network Configuration** page, in the Micro Motion web pages, allows you to set the IP address, gateway address, and subnet address. If you connect to the EtherNet/IP Module using a crossover cable and the default IP address, you can set all three parameters. The changes will take effect at the next connection.

3.1.2 Configuration switches



If the configuration switches on the EtherNet/IP module are set to any non-zero value, the device is locked to the following network settings:

Table 3-1: Network settings, locked

Parameter	Value
IP address	192.168.0.x where x is determined by the switches
Gateway	192.168.0.255
Subnet	255.255.255.0
DHCP	OFF

Table 3-2: Network settings using switches

Switch								IP address
1	2	3	4	5	6	7	8	
OFF	OFF	OFF	OFF	OFF	OFF	OFF	ON	192.168.0.1
OFF	OFF	OFF	OFF	OFF	OFF	ON	OFF	192.168.0.2
OFF	OFF	OFF	OFF	OFF	OFF	ON	ON	192.168.0.3
...
ON	ON	ON	ON	ON	ON	ON	OFF	192.168.0.254
ON	ON	ON	ON	ON	ON	ON	ON	Invalid

3.1.3 Ethernet Config Tool

See the Anybus Communicator manual for instructions.

Note

If you change the network settings using the Ethernet Config Tool, you will not be able to use the Micro Motion web pages to change network settings in the future. All future changes to network settings must be performed using the Ethernet Config Tool.

3.1.4 Set the configuration switches with ethcfg.cfg file

To set the network settings using the `\ethcfg.cfg` file:

Procedure

1. Set all configuration switches on the device to OFF.
2. Make a connection to the device from the Ethernet Config Tool and disable TCP/IP Settings (Fieldbus parameter section). Alternatively, you can access the TCP/IP parameters using the TCP/IP Interface Object.
3. From the FTP server, access and edit `\ethcfg.cfg` as desired.

In this scenario, if no `\ethcfg.cfg` file is found, the EtherNet/IP Module will attempt to retrieve the settings via DHCP for 30 seconds. If the attempt fails, the EtherNet/IP Module will halt and indicate an error via the LEDs.

See the Anybus Communicator manual for more information.

3.1.5 IP access control

You can limit the set of IP addresses that are allowed to connect to the EtherNet/IP Module. This information is stored in the system file `\ip_accs.cfg`.

Sample file:

```
[Web]
xxx.xxx.xxx.xxx (All nodes listed can access the EtherNet/IP
Module web
server)
```



```

...
[FTP]
xxx.xxx.xxx.xxx (All nodes listed can access the EtherNet/IP
Module FTP
server)
...
[EtherNet/IP]
xxx.xxx.xxx.xxx (All nodes listed can access the EtherNet/IP
Module via
EtherNet/IP)
...
[All]
xxx.xxx.xxx.xxx (Fallback setting; used when one or more of the
above
keys is omitted)
...

```

3.2 Modbus serial network settings

The default parameters for the Modbus serial network are listed in the following table.

Parameter	Default setting	Valid values
Baud	38400	1200 to 57600
Data bits	8 (Modbus RTU)	7 (Modbus ASCII) 8 (Modbus RTU)
Parity	None	None Odd Even
Physical layer	RS485	RS485 (required for EtherNet/IP Module)
Start bits	1	1
Stop bits ⁽¹⁾	2	1 2

(1) For baud rates of 38400 and above, 2 stop bits are required.

These must match the RS-485 parameters configured in the transmitter. To change them in the EtherNet/IP Module, you must use the Ethernet Config Tool. See the Anybus Communicator manual for more information.

4 Emerson web server

The configuration and administration functions of the Micro Motion EtherNet/IP Module are implemented as web pages on the device. Users use their web browsers to connect to the web server. Your browser will automatically directed to the Emerson web pages.

4.1 Web server access information

Ports

The web server communicates through port 80.

Users

Two users are predefined for the Emerson web pages. You can change the passwords, but you cannot add or delete users.

Username	Default password	Description
admin	admin	Complete access to all functions on the Emerson web pages
operator	operator	Read-only access to the Emerson web pages

4.2 Emerson EtherNet/IP Module web pages

When you connect to the EtherNet/IP Module, you are prompted for a user name and password, then directed to the EtherNet/IP Module home page.

Use the web pages to do the following tasks:

- Administer passwords and the EDS file download
- Administer network configurations
- Monitor, configure, and maintain process data, totalizers, Smart Meter Verification, etc.

Note

If the EtherNet/IP Module loses communication with the Micro Motion device, the web page will indicate the communication error between the EIP module and the Micro Motion transmitters.

For more details, refer to the transmitter configuration manual.

5 Integrate with Rockwell programming software

5.1 Integrate with Rockwell versions 20 or later

If you have Rockwell RSLogix 5000 or Studio 5000 Logix Designer version 20 or later firmware and programming software, use this section to load the Electronic Data Sheet (EDS) and commission the device using the RSLogix 5000 programming package.

Prerequisites

If you are upgrading the EDS from an older version, unregister the old EDS first using the RSLogix EDS Hardware Installation Tool at **Tools > EDS Hardware Installation Tool**.

Procedure

1. Connect to the EtherNet/IP module through your web browser and download the EDS file.
See [Emerson web server](#).
2. In RSLogix 5000, choose **Tools > EDS Hardware Installation Tool** and register the EtherNet/IP module EDS file.
3. If you have an established RSLogix Ethernet network, skip this step. If not, follow these steps to create a network:
 - a) From RSLogix 5000, right-click the controller/backplane in the tree view.
 - b) Select **New Module**.
 - c) Select the appropriate Ethernet card.
 - d) Select **Create**.
 - e) Enter the **Name**.
 - f) Enter the **IP Address**.
 - g) Select the **Slot** where your Ethernet card is located.
 - h) Select **OK**.
 - i) On the **Select Module Type** window, select **Close**.
4. To add the Micro Motion EtherNet/IP module to the RSLogix 5000 Ethernet network, right-click the Ethernet network and select **New Module**.
 - a) From the **Select Module Type** window, select the following options and select **Create**:

Pane	Option
Module Type Category Filters	Communications Adapter
Module Type Vendor Filters	Micro Motion, Inc.

The **New Module** properties dialog displays. The EDS generates an Add On Profile (AOP) for the Micro Motion Ethernet/IP module that loads all the

variables into the controller's input and output image tables as named variables with the correct data types.

- b) Enter the **Name** of the module.
 - c) Enter the **IP Address**.
5. Change or keep the current connection type.

Change the connection type	Go to Step 6
Keep the current connection type	Go to Step 7

6. To change the connection type, select the **General** tab, change the connection type.

- a) Select the **Change** button.
- b) Select the current connection.

Default = IO Connection

A pull-down menu with all the available connection types displays.

- c) Select your appropriate connection, and press **OK**.

Important

If you change the connection after the device goes online, take the controller offline for the change to take effect.

7. To keep the current connection type:

- a) Select the current connection.

Default = IO Connection

A pull-down menu with all available connection types displays.

- b) Select a connection and press **OK**.

Important

If you change the connection after the device goes online, take the controller offline for the change to take effect.

- 8. On the **New Module** properties dialog, select **OK**.
- 9. On the **Select Module Type** dialog, select **Close**.
- 10. Open **Controller Tags** to verify the data organization.

5.2 Integrate with Rockwell versions 19 or earlier

Use this section if you have Rockwell RSLogix 5000 version 19 or earlier firmware and programming software. These early versions do not support Micro Motion Ethernet/IP module Electronic Data Sheet (EDS)-generated Add On Profile (AOP). Instead, you must use the generic module hardware tree.

Procedure

- 1. Connect to the EtherNet/IP module through your web browser and download the EDS file.

See [Emerson web server](#).

2. In RSLogix 5000, choose **Tools > EDS Hardware Installation Tool** and register the EtherNet/IP module EDS file.
3. If you have an established RSLogix Ethernet network, skip this step. If not, follow these steps to create a network:
 - a) From RSLogix 5000, right-click the controller/backplane in the tree view.
 - b) Select **New Module**.
 - c) Select the appropriate Ethernet card.
 - d) Select **Create**.
 - e) Enter the **Name**.
 - f) Enter the **IP Address**.
 - g) Select the **Slot** where your Ethernet card is located.
 - h) Select **OK**.
 - i) On the **Select Module Type** window, select **Close**.
4. From RSLogix 5000, choose **File > New**.
5. Select your version from the **Revision** drop-down menu.
6. Enter a **Name** for your application.
7. Select the **Slot** where your Ethernet card is located.
8. Press **OK**.
9. To add the Micro Motion EtherNet/IP module to the RSLogix 5000 Ethernet network, right-click the Ethernet network and select **New Module**.
 - a) Select the **ETHERNET-MODULE Generic Ethernet Module** and press **OK**.
10. Select the appropriate assembly instances for your application. Enter the assembly numbers in the generic module setup, along with the data sizes.

Note

If your **Comm Format** is anything other than **Data-INT**, the data sizes will be different from the sizes shown in the following tables.

Table 5-1: Standard configuration

Parameter	Entry
Name	MicroMotion_EIP
Description	Micro Motion EtherNet/IP Module Basic Configuration
Comm Format	Data-INT
IP Address	<i>Your IP address</i>
Input	Assembly Instance: 100 Size: 20
Output	Assembly Instance: 150 Size: 7

Table 5-1: Standard configuration (continued)

Parameter	Entry
Configuration	Assembly Instance: 3 Size: 0

Table 5-2: Concentration measurement

Parameter	Entry
Name	MicroMotion_EIP
Description	Micro Motion EtherNet/IP Module CM
Comm Format	Data-INT
IP Address	Your IP address
Input	Assembly Instance: 100 Size: 42
Output	Assembly Instance: 150 Size: 7
Configuration	Assembly Instance: 3 Size: 0

Table 5-3: Petroleum measurement

Parameter	Entry
Name	MicroMotion_EIP
Description	Micro Motion EtherNet/IP Module PM
Comm Format	Data-INT
IP Address	Your IP address
Input	Assembly Instance: 100 Size: 30
Output	Assembly Instance: 150 Size: 7
Configuration	Assembly Instance: 3 Size: 0

11. Press **OK**.
12. Open **Controller Tags** to see the data organization.
13. Use your preferred programming techniques to convert the data from the input and output image tables to the correct data types.

If you are not using RSLogix or Studio 5000 Logix designer, use your standard method. For information on I/O assemblies, see [I/O data](#).

6 Troubleshooting

6.1 LED indicators



LED number	Name	Status	Description
A	Module Status (EtherNet)	Off	No power applied to the module.
		Solid green	The module is operating correctly.
		Flashing green	Standby. The module has not been initialized.
		Flashing red	Minor fault. The module may or may not be able to recover.
		Solid red	Major fault. No recovery is possible. The module must be returned to Micro Motion for repair. See the manual for the return policy.
		Flashing green/red	Self-test.
B	Network Status (EtherNet)	Off	The module has not power or no IP address has been assigned.
		Solid green	The module has at least one established EtherNet/IP connection.
		Flashing green	There are no EtherNet/IP connections established to the module.
		Flashing red	One or more of the connections to this module has timed out.
		Solid red	The module has detected that its IP address is already in use.
		Flashing green/red	Self-test.
C	Link	Off	The module does not sense a link.
		Green	The module is connected to an Ethernet network.
D	Activity	Flashing green	Packet is received or transmitted.

LED number	Name	Status	Description
E	Subnet Status (Modbus Serial)	Off	Power off.
		Flashing green	Running correctly, but one or more transaction errors has occurred.
		Green	Running.
		Red	Transaction error/timeout or network stopped. Check the Modbus serial network wiring and configuration, especially the baud.
		Flashing red	Missed transactions.
F	Device Status (Modbus Serial)	Off	Power off.
		Flashing red/green	Configuration missing or invalid.
		Red	Contact customer service.
		Flashing red	Contact customer service.
		Green	Initializing.
		Flashing green	Configuration OK.

6.2 Common problems

6.2.1 Configuration upload or download problem

Cause

The serial communication failed.

Recommended actions

Try again.

6.2.2 Red Config Line LED

The Config Line LED turns red in the Ethernet Config Tool.

Cause

The serial communication failed.

Recommended actions

Try again.

6.2.3 Cannot connect to the EtherNet/IP Module

The serial port seems to be available, but it is not possible to connect to the EtherNet/IP Module.

Cause

The serial port may be in use by another application.

Recommended actions

1. Exit the EtherNet/IP Module Configuration Tool and close all other applications, including the ones in the system tray.
2. Try again.
3. Select another serial port.
4. Try again.

6.2.4 Poor performance

Cause

The serial communication failed.

Recommended actions

1. In the Ethernet Config Tool, right-click **Sub-Network** in the **Navigation** window.
 - a) Select **Sub-Network Status** to see status and diagnostic information about the Modbus serial network.
 - b) If the EtherNet/IP Module reports a large number of re-transmissions, check your cabling or try a lower baud rate setting for the Modbus serial network, if possible.
2. Is the **Sub-Net Monitor** in the Ethernet Config Tool active?
The sub-network monitor has a negative influence on the overall performance of the gateway, and should be used only when necessary.
3. Is the **Node Monitor** of the Ethernet Config Tool active?
The node monitor has a negative influence on the overall performance of the gateway, and should be used only when necessary.

6.2.5 No Modbus serial network functionality

Recommended actions

1. Connect to the device and login to the webserver. Allow the web server to automatically configure the device's process variable slot.
2. Use the Data logger functionality of the Ethernet Config Tool to record the serial data communication on the sub-network.
3. If no data is being transmitted, use the Ethernet Config Tool to record the serial data communication on the sub-network.

4. If no data is being received, check the cables and connections. Also verify that the transmitted data is correct.

6.2.6 Process variables display or report 0

Recommended actions

Verify the Modbus connection between the EtherNet/IP Module and the device.

A Connector pin assignments

A.1 Ethernet connector

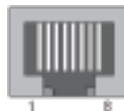

Pin	Signal
Housing	Cable shield
1	TD+
2	TD-
3	RD+
4	Termination
5	Termination
6	RD-
7	Termination
8	Termination

A.2 Power connector

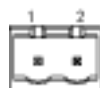

Pin	Description
1	24 VDC
2	Ground

- Use 60/75 or 75 x C copper (CU) wire only.
- The terminal tightening torque must be between 5 and 7 lbs-in (0.5 to 0.8 Nm).

A.3 Micro Motion Ethernet Config Tool installation (optional)

Related tasks

[Install the Ethernet Config Tool](#)

A.3.1 Ethernet Config Tool system requirements

- Pentium 133 MHz or higher
- 10 MB of free space
- 8 MB RAM
- Windows NT v4.0 or higher, Windows 2000, or Windows XP
- Internet Explorer v4.01 SP1 or higher

A.3.2 Install the Ethernet Config Tool

Procedure

1. Install the software program. Locate and run the EtherNet/IP Module setup program on the EtherNet/IP Module Resource CD and follow the on-screen instructions.
2. Connect the configuration cable from your PC to the EtherNet/IP Module.

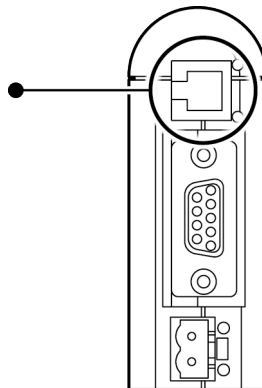

Note

For information on the Micro Motion Ethernet Config Tool user interface, see the Anybus Communicator manual.

Related concepts

[Micro Motion Ethernet Config Tool installation \(optional\)](#)

A.4 Modbus serial network interface

The Modbus serial network is based on an RS-485 physical layer.

A.4.1 Bias resistors

When idle, RS-485 enters an indeterminate state, which may cause the serial receivers to pick up noise from the serial lines and interpret this as data. To prevent this, the serial lines should be forced into a known state using pull-up and pull-down resistors, commonly known as bias resistors.

The bias resistors forms a voltage divider, forcing the voltage between the differential pair to be higher than the threshold for the serial receivers, typically >200 mV. Note that bias resistors shall only be installed on one node. Installing bias resistors on several nodes may compromise the signal quality on the network and cause transmission problems.

A.4.2 Termination

To avoid reflections on the serial lines, it is important to properly terminate the sub-network by placing termination resistors between the serial receivers near the end nodes.

Additionally, if the distance from the EtherNet/IP Module to the transmitter is greater than 100 feet, Micro Motion recommends adding the termination resistors.

The resistor value should ideally match the characteristic impedance of the cable, typically 100 to 120 Ω.

A.4.3 Pin assignments (EtherNet/IP Module)

Figure A-1: Female connection



Pin	Description
1	5 V output (100mA max)
2	Unused
3	Unused
4	Unused
5	Ground
6	Unused
7	Unused
8	RS-485/A (Tx+)
9	RS-485/B (Tx-)
(housing)	Cable shield

A.5 Typical connection

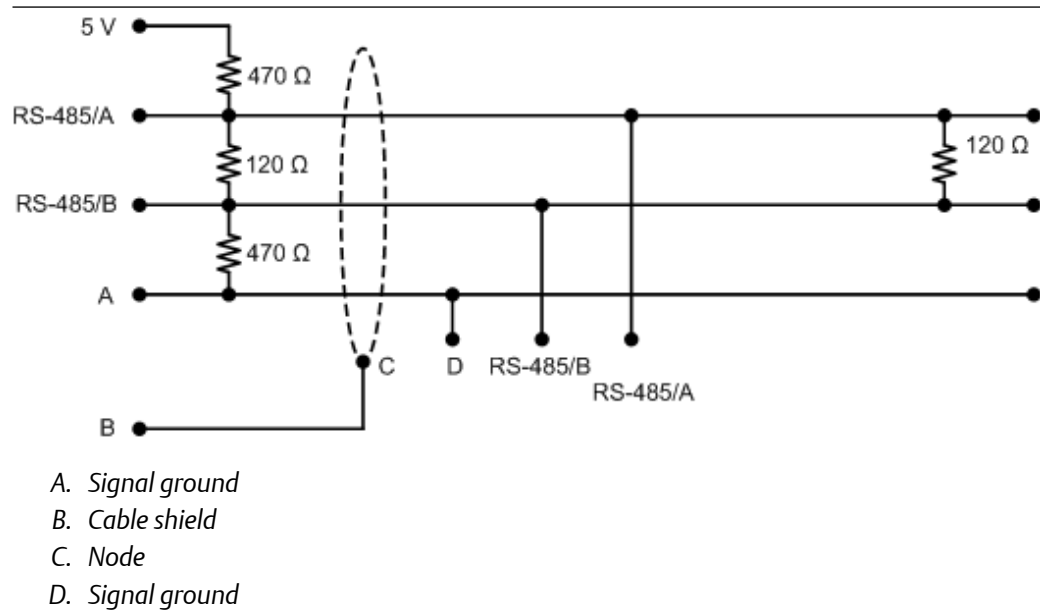

B Device profile

B.1 Object classes

Table B-1 lists and describes all object classes supported by the EtherNet/IP Module.

Table B-1: Object classes and descriptions

Object	Class ID	Optional/ required	Description
Identity	0x01	Required	Contains information that uniquely describes the device
Message Router	0x02	Required	Tracks the accessibility of the object classes and instances
Assembly	0x04	Required	Contains a list of attributes that data can be written to (sink) or read from (source)
Port	0xF4	Required	
TCP/IP Interface	0xF5	Required	Groups settings related to TCP/IP.
Ethernet Link	0xF6	Required	Groups diagnostic information for the Ethernet interface
Diagnostic	0xAA	Optional	Groups diagnostic information for the fieldbus interface
Parameter Data Input Mapping	0xB0	Optional	Used for acyclic access to input data
Parameter Data Output Mapping	0xB1	Optional	Used for acyclic access to output data

B.2 Object details

B.2.1 Identity Object, Class 01h

This object provides identification of and general information about the device. It contains informational attributes that uniquely describe the device.

Example: The use of attributes Vendor ID, Device Type, Product Code, and Serial Number together uniquely identify this device.

Supported services

Class services:

- Get Attribute All
- Get Attribute Single

Instance services:

- Get Attribute All
- Get Attribute Single
- Reset

Class attributes

#	Access	Name	Type	Value	Description
1	Get	Revision	UINT	0001h	Revision 1

Instance attributes

#	Access	Name	Type	Value	Description
1	Get	Vendor ID	UINT	Default: 0392h	Micro Motion Inc
2	Get	Device Type	UINT	Default: 000Ch	Communication Adapter
3	Get	Product Code	UINT	Default: 0002h	2 = Micro Motion EtherNet/IP Module
4	Get	Revision	Struct of:	-	
			USINT		Major fieldbus version
			USINT		Minor fieldbus version
5	Get	Status	WORD	-	Device status; see following table
6	Get	Serial Number	UDINT	Serial number	(set at production)
7	Get	Product Name	SHORT_STRING	"Micro Motion EtherNet/IP Module"	Name of product

Device status

Bit(s)	Name	
0	Module Owned	
1	(reserved)	
2	Configured	
3	(reserved)	
4... 7	Extended Device Status:	
	Value	Meaning

Bit(s)	Name	
	0000b	Unknown
	0010b	Faulted I/O Connection
	0011b	No I/O connection established
	0100b	Non-volatile configuration bad
	0110b	Connection in Run mode
	0111b	Connection in Idle mode
	(other)	(reserved)
8	Set for minor recoverable faults	
9	Set for minor unrecoverable faults	
10	Set for major recoverable faults	
11	Set for major unrecoverable faults	
12... 15	(reserved)	

Reset service

When the Identity Object receives a Reset request, it:

- Determines if it can provide the type of reset requested
- Responds to the request
- Attempts to perform the type of reset requested

B.2.2 Message Router, Class 02h

The Message Router Object provides a messaging connection point through which a Client may address a service to any object class or instance residing in the physical device.

B.2.3 Assembly Object, Class 04h

The Assembly Object binds attributes of multiple objects, which allows data to or from each object to be sent or received over a single connection. Assembly objects can be used to bind input data or output data. The terms “input” and “output” are defined from the network’s point of view. An input produces data on the network and an output consumes data from the network.

This object provides access to the I/O Data in the Input and Output Data areas in the Micro Motion EtherNet/IP Module.

Supported services

Class services: Get Attribute Single

Instance services:

- Get Attribute Single

- Set Attribute Single

Class attributes

#	Access	Name	Type	Value	Description
1	Get	Revision	UINT	0002h	Revision 2
2	Get	Max Instance	UINT	-	The highest initiated instance number

Instance attributes - Instance/Connection Point 64h

This instance corresponds to I/O Data (Input) in the Micro Motion EtherNet/IP Module. The EtherNet/IP Module supports two different configurations. Specific input assembly attributes depend on the configuration in use.

Configuration	Input assembly attributes
Basic	See Input assembly for standard configuration
Concentration measurement	See Input assembly for concentration measurement configuration

Note

The default input data size is non-zero. The actual size depends on the configuration in use. If the I/O input data size is set to 0, this instance will NOT be initialized.

#	Access	Name	Type	Value	Description
3	Get	Data	Array of BYTE	-	Data produced by the Micro Motion EtherNet/IP Module

Instance attributes - Instance/Connection Point 96h

This instance corresponds to I/O Data (Output) in the Micro Motion EtherNet/IP Module. The EtherNet/IP Module supports two different configurations. Specific input assembly attributes depend on the configuration in use.

Configuration	Output assembly attributes
Basic	See Output assembly for standard configuration
Concentration measurement	See Output assembly for concentration measurement configuration

Note

The default output data size is non-zero. The actual size depends on the configuration in use. If the I/O output data size is set to 0, this instance will NOT be initialized.

#	Access	Name	Type	Value	Description
3	Set	Data	Array of BYTE	-	Data consumed by the Micro Motion EtherNet/IP Module

Note

Rockwell Automation PLCs have the first four bytes consumed by a device defined as status information. This behavior is specific to devices from Rockwell Automation and is not defined in the EtherNet/IP specification. However, since all known PLCs are implemented this way, the Micro Motion EtherNet/IP Module adopts this behavior and strips off the corresponding four bytes from the consumed data.

B.2.4 Port Object, Class F4h

Supported services

Class services:

- Get Attribute Single
- Get Attribute All

Instance services:

- Get Attribute Single
- Get Attribute All

Class attributes

#	Access	Name	Type	Value	Description
1	Get	Revision	UINT	0001h	Revision 1
2	Get	Max Instance	UINT	0002h	2 is the highest instance number
3	Get	No. of instances	UINT	0001h	1 instance is implemented
8	Get	Entry Port	UINT	0002h	Returns the instance of the Port object that describes the port.
9	Get	All Ports	Array of STRUCT	0000h 0000h	Array of structure containing attributes 1 and 2 from each instance. Instance 1 is at byte offset 4. Instance 2 is at byte offset 8, etc. The 4 bytes at offset 0 shall be 0. (Default)
			{UINT; UINT;}	0000h 0000h	
				0004h 0002h	

Instance attributes, Instance 02h

#	Access	Name	Type	Value	Comments
1	Get	Port Type	UINT	0000h	TCP/IP
2	Get	Port Number	UINT	0002h	Port 2
3	Get	Port Object	Struct of:		
		Path Size	UINT	0002h	-
		Path	Padded EPATH	20 F5 24 01h	TCP class, Instance 1
4	Get	Port Name	SHORT_STRING	"TCP/IP"	Name of port

#	Access	Name	Type	Value	Comments
8	Get	Node Address	Padded EPATH	-	-

B.2.5 TCP/IP Interface Object, Class F5h

This object groups TCP/IP-related settings.

Supported services

Class services:

- Get Attribute All
- Get Attribute Single

Instance services:

- Get Attribute All
- Get Attribute Single
- Set Attribute Single

Class attributes

#	Access	Name	Type	Value	Comments
1	Get	Revision	UINT	0001h	Revision 1
2	Get	Max Instance	UINT	0001h	1 is the highest instance number
3	Get	No. of instances	UINT	0001h	1 instance is implemented

Instance attributes

#	Access	Name	Type	Value	Comments
1	Get	Status	DWORD	00000001h	Attribute #5 contains valid information.
2	Get	Configuration Capability	DWORD	00000016h	Attribute #5 is settable. Capable of obtaining network configuration via DHCP.
3	Get/Set	Configuration Control	DWORD	-	0: Configuration from non-volatile memory 2: Configuration from DHCP
4	Get	Port Object	Struct of:		
		Path Size	UINT	0002h	2 words
		Path	Padded EPATH	20 F6 24 01h	Path to Ethernet Class, Instance 1
5	Get/Set	Interface Configuration	Struct of:		
		IP Address	UDINT	-	IP address

#	Access	Name	Type	Value	Comments
		Subnet Mask	UDINT	-	Subnet mask
		Gateway Address	UDINT	-	Gateway Address
		Name Server 1	UDINT	-	Primary DNS
		Name Server 2	UDINT	-	Secondary DNS
		Domain Name	STRING	-	Default domain name
6	Get/Set	Host Name	STRING	-	Host name

B.2.6 Ethernet Link Object, Class F6h

This object groups diagnostic information for the Ethernet interface.

Supported services

Class services:

- Get Attribute All
- Get Attribute Single

Instance services:

- Get Attribute All
- Get Attribute Single

Class attributes

#	Access	Name	Type	Value	Description
1	Get	Revision	UINT	0001h	Revision 1
2	Get	Max Instance	UINT	0001h	1 is the highest instance number
3	Get	No. of instances	UINT	0001h	1 instance is implemented

Instance attributes

#	Access	Name	Type	Value	Comments
1	Get	Interface Speed	UDINT	10 or 100	Actual Ethernet interface speed
2	Get	Interface Flags	DWORD	-	-
3	Get	Physical Address	Array of 6 USINTS	(MAC ID)	Physical network address

B.2.7 Diagnostic Object, Class AAh

This object groups diagnostic information for the fieldbus interface.

Supported services

Class services: Get Attribute All

Instance services: Get Attribute Single

Class attributes

#	Access	Name	Type	Value	Description
1	Get	Revision	UINT	0001h	Revision 1

Instance attributes

#	Access	Name	Type	Description
01h	Get	Module serial number	UDINT	Serial number
02h	Get	Vendor ID	UINT	Manufacturer Vendor ID
03h	Get	Fieldbus Type	UINT	Fieldbus Type
04h	Get	Module Software version	UINT	Module software version
0Ah	Get	Module Type	UINT	Module Type
0Fh	Get	IN cyclic I/O length	UINT	Size of I/O Input area (in bytes)
11h	Get	IN total length	UINT	Total number of IN bytes supported
12h	Get	OUT cyclic I/O length	UINT	Size of I/O Output area (in bytes)
14h	Get	OUT total length	UINT	Total number of OUT bytes supported

B.2.8 Parameter Data Input Mapping Object, Class B0h

This object can be used to access Input Data acyclically, and is set up dynamically based on the Parameter Data Mailbox initialization (see [Input parameters \(explicit data\) for standard configuration](#)).

Supported services

Class services: Get Attribute All

Instance services: Get Attribute Single

Class attributes

#	Access	Name	Type	Value	Description
1	Get	Revision	UINT	0001h	Revision 1

Instance attributes, Instance 01h

Each attribute corresponds to a block of Input Data.

#	Access	Name	Type	Description
01h	Get	Data	Array of USINT	Mapped block of Input Data

#	Access	Name	Type	Description
02h	Get	Data	Array of USINT	Mapped block of Input Data
...				
32h	Get	Data	Array of USINT	Mapped block of Input Data

The specific parameters in the block depend on the configuration in use.

Configuration	Input parameters (explicit data)
Basic	See Input parameters (explicit data) for standard configuration
Concentration measurement	See Input parameters (explicit data) for concentration measurement configuration

B.2.9 Parameter Data Output Mapping Object, Class B1h

This object can be used to access Output Data acyclically, and is set up dynamically (see [Output parameters \(explicit data\) for standard configuration](#)).

Supported services

Class services: Get Attribute All

Instance services:

- Get Attribute Single
- Set Attribute Single

Class attributes

#	Access	Name	Type	Value	Description
1	Get	Revision	UINT	0001h	Revision 1

Instance attributes, Instance 01h

#	Access	Name	Type	Description
01h	Get/Set	Data	Array of USINT	Mapped block of Output Data
02h	Get/Set	Data	Array of USINT	Mapped block of Output Data
...				
32h	Get/Set	Data	Array of USINT	Mapped block of Output Data

The specific parameters in the block depend on the configuration in use.

Configuration	Output parameters (explicit data)
Basic	See Output parameters (explicit data) for standard configuration

Configuration	Output parameters (explicit data)
Concentration measurement	See Output parameters (explicit data) for concentration measurement configuration

B.3 I/O data

B.3.1 Input assembly for standard configuration

Byte	Access	Name	Type	Notes
0–3	Get	Mass flow rate	Float	
4–7	Get	Density	Float	
8–11	Get	Temperature	Float	
12–15	Get	Volume flow rate (liquid volume)	Float	Valid only when Gas Standard Volume is not enabled.
16–19	Get	Mass total	Float	
20–23	Get	Volume total (liquid volume)	Float	
24–27	Get	Drive gain	Float	
28–29	Get	Status word	U16 or Word	<ul style="list-style-type: none"> For Model 1700 Analog, Model 2700 Analog, Model 1500 Analog, Model 2500, and all Series 3000 transmitters: SNS Status Word 1 (see Status Word 1) For MVD Direct Connect and 9739 MVD transmitters: SNS Status Word 2 (see Status Word 2)
30–31	Get	Status word	U16 or Word	<ul style="list-style-type: none"> For Model 1700 Analog, Model 2700 Analog, Model 1500 Analog, Model 2500, and all Series 3000 transmitters: SNS Status Word 2 (see Status Word 2) For MVD Direct Connect and 9739 MVD transmitters: SNS Status Word 1 (see Status Word 1)
32–35	Get	Gas standard volume flow rate	Float	Valid only when Gas Standard Volume is enabled.
36–39	Get	Gas standard volume total	Float	Valid only when Gas Standard Volume is enabled.

B.3.2 Output assembly for standard configuration

Byte	Access	Name	Type	Notes
0–3	Get/Set	External Temperature	Float	

Byte	Access	Name	Type	Notes
4–7	Get/Set	External Pressure	Float	
8	Get/Set	Start/Stop Totals	Byte	0: Stop 1: Start
9	Get/Set	Reset All Process Totals	Byte	0: No action 1: Reset
10	Get/Set	Reset All Inventory Totals	Byte	0: No action 1: Reset
11	Get/Set	Start Zero	Byte	0: Abort or no action 1: Start
12–13	Get/Set	Start Smart Meter Verification	Word	See Table B-20

B.3.3 Input parameters (explicit data) for standard configuration

To update any of these attribute values, the associated trigger byte must be toggled before reading the attribute value (executing the Get service). See [Output parameters \(explicit data\) for standard configuration](#) for more information on trigger bytes.

Class B0h, Instance 01h

Attribute	Access	Name	Type	Trigger Byte WriteAttribute	Description
01h	Get	Mass flow rate unit	U16	0Ch	See Table B-7
02h	Get	Density unit	U16	0Ch	See Table B-13
03h	Get	Temperature unit	U16	0Ch	See Table B-14
04h	Get	Volume flow rate unit	U16	0Ch	See Table B-9
05h	Get	Pressure unit	U16	0Ch	See Table B-15
06h	Get	Mass total/inventory unit	U16	0Ch	See Table B-8
07h	Get	Volume total/inventory unit	U16	0Ch	See Table B-10
08h	Get	Zero time	U16	0Dh	Seconds
09h	Get	Standard deviation of auto zero	Float	0Eh	
0Ah	Get	Present flow signal offset at zero flow	Float	0Eh	
0Bh	Get	Failed Zero Calibration Value	Float	0Eh	

Attribute	Access	Name	Type	Trigger Byte WriteAttribute	Description
0Ch	Get	Device Status Word 2	U16	0Fh	See Status Word 2
0Dh	Get	Device Status Word 3	U16	0Fh	See Status Word 3
0Eh	Get	Device Status Word 4	U16	0Fh	See Status Word 4
0Fh	Get	Device Status Word 5	U16	0Fh	See Status Word 5
10h	Get	Device Status Word 6	U16	0Fh	See Status Word 6
11h	Get	Device Status Word 7	U16	0Fh	See Status Word 7
12h	Get	External temperature input	Float	No trigger byte	
13h	Get	External pressure input	Float	No trigger byte	
14h	Get	Gas standard volume flow unit	U16	10h	See Table B-11
15h	Get	Gas standard volume total/ inventory unit	U16	10h	See Table B-12
16h	Get	Smart Meter Verification: Status	U16	13h	See Table B-22
17h	Get	Smart Meter Verification: Run Count	U16	13h	
18h	Get	Smart Meter Verification Algorithm State	U16	11h	See Table B-21
19h	Get	Smart Meter Verification Abort Code	U16	11h	See Table B-23
1Ah	Get	Smart Meter Verification State at Abort	U16	11h	See Table B-24
1Bh	Get	Smart Meter Verification Progress	U16	12h	% complete
1Ch	Get	Enable/Disable Gas Standard Volume Calculations	U8	14h	
1Dh	Get	Subnet communication status (RS-485 connection to transmitter)	U16	No trigger byte	0: Communications failure Any other value: Communications good

B.3.4 Output parameters (explicit data) for standard configuration

Class B1h, Instance 01h

Attribute	Access	Name	Type	Trigger byte write attribute	Description
01h	Get/Set	Standard or special mass flow rate unit	U16		See Table B-7
02h	Get/Set	Density unit	U16		See Table B-13
03h	Get/Set	Temperature unit	U16		See Table B-14
04h	Get/Set	Standard or special volume flow rate unit	U16		See Table B-10
05h	Get/Set	Pressure unit	U16		See Table B-15
06h	Get/Set	Zero time	U16		Seconds
07h	Get/Set	Zero value	Float		
08h	Get/Set	Gas Standard Volume Flow unit	U16		See Table B-11
09h	Get/Set	Output state during Smart Meter Verification	U16		0 = Last measured value 1 = Fault
0Ah	Get/Set	Enable/Disable Gas Standard Volume Calculations	U8		
0Bh	Get/Set	Smart Meter Verification Index	U16	16h	Smart Meter Verification test record. 0 = most recent ... 19 = oldest
0Ch	Get/Set	Trigger Byte-2	U8		
0Dh	Get/Set	Trigger Byte-3	U8		
0Eh	Get/Set	Trigger Byte-6	U8		
0Fh	Get/Set	Trigger Byte-9	U8		
10h	Get/Set	Trigger Byte-15	U8		
11h	Get/Set	Trigger Byte-17	U8		
12h	Get/Set	Trigger Byte-18	U8		
13h	Get/Set	Trigger Byte-16	U8		
14h	Get/Set	Trigger Byte-20	U8		
15h	Get/Set	Trigger Byte-23	U8		

Attribute	Access	Name	Type	Trigger byte write attribute	Description
16h	Get/Set	Trigger Byte-26	U8		

B.3.5 Input assembly for concentration measurement configuration

Byte	Access	Name	Type	Notes
0-3	Get	Mass flow rate	Float	
4-7	Get	Density	Float	
8-11	Get	Temperature	Float	
12-15	Get	Volume flow rate (liquid volume)	Float	
16-19	Get	Mass total	Float	
20-23	Get	Standard volume flow	Float	
24-27	Get	Standard volume total	Float	
28-31	Get	Standard volume inventory	Float	
32-35	Get	Net mass flow	Float	
36-39	Get	Net mass total	Float	
40-43	Get	Netmass inventory	Float	
44-47	Get	Net volume flow	Float	
48-51	Get	Net volume total	Float	
52-55	Get	Net volume inventory	Float	
56-59	Get	Reference density	Float	
60-63	Get	Specific gravity	Float	
64-67	Get	Concentration	Float	
68-71	Get	Density (fixed Baume units)	Float	
72-75	Get	Volume total (liquid)	Float	
76-79	Get	Drive gain	Float	

Byte	Access	Name	Type	Notes
80–81	Get	Status word	U16 or Word	<ul style="list-style-type: none"> For Model 1700 Analog, Model 2700 Analog, Model 1500 Analog, Model 2500, and all Series 3000 transmitters: SNS Status Word 1 (see Status Word 1) For MVD Direct Connect and 9739 MVD transmitters: SNS Status Word 2 (see Status Word 2)
82–83	Get	Status word	U16 or Word	<ul style="list-style-type: none"> For Model 1700 Analog, Model 2700 Analog, Model 1500 Analog, Model 2500, and all Series 3000 transmitters: SNS Status Word 2 (see Status Word 2) For MVD Direct Connect and 9739 MVD transmitters: SNS Status Word 1 (Status Word 1)

B.3.6 Output assembly for concentration measurement configuration

Byte	Access	Name	Type	Notes
0–3	Get/Set	External Temperature	Float	
4–7	Get/Set	External Pressure	Float	
8	Get/Set	Start/Stop Totals	Byte	0: Stop 1: Start
9	Get/Set	Reset All Process Totals	Byte	0: No action 1: Reset
10	Get/Set	Reset All Inventory Totals	Byte	0: No action 1: Reset
11	Get/Set	Start Zero	Byte	0: Abort or no action 1: Start
12–13	Get/Set	Start Smart Meter Verification	Word	See Table B-20

B.3.7 Input parameters (explicit data) for concentration measurement configuration

To update any of these attribute values, the associated trigger byte must be toggled before reading the attribute value (executing the Get service). See [Output parameters \(explicit data\) for standard configuration](#) for more information on trigger bytes.

Class 0h, Instance 01h

Attribute	Access	Name	Type	Trigger Byte WriteAttribute	Description
01h	Get	Mass flow rate unit	U16	0Ah	See Table B-7
02h	Get	Density unit	U16	0Ah	See Table B-13
03h	Get	Temperature unit	U16	0Ah	See Table B-14
04h	Get	Volume flow rate unit	U16	0Ah	See Table B-9
05h	Get	Pressure unit	U16	0Ah	See Table B-15
06h	Get	Mass total/inventory unit	U16	0Ah	See Table B-8
07h	Get	Volume total/inventory unit	U16	0Ah	See Table B-10
08h	Get	Zero time	U16	0Bh	Seconds
09h	Get	Standard deviation of auto zero	Float	0Ch	
0Ah	Get	Present flow signal offset at zero flow	Float	0Ch	
0Bh	Get	Failed Zero Calibration Value	Float	0Ch	
0Ch	Get	Device Status Word 2	U16	0Dh	See Status Word 2
0Dh	Get	Device Status Word 3	U16	0Dh	See Status Word 3
0Eh	Get	Device Status Word 4	U16	0Dh	See Status Word 4
0Fh	Get	Device Status Word 5	U16	0Dh	See Status Word 5
10h	Get	Device Status Word 6	U16	0Dh	See Status Word 6
11h	Get	Device Status Word 7	U16	0Dh	See Status Word 7
12h	Get	External temperature input	Float	No trigger byte	
13h	Get	External pressure input	Float	No trigger byte	
14h	Get	Smart Meter Verification: Run Count	U16	0Eh	
15h	Get	Smart Meter Verification: Status	U16	0Eh	See Table B-22
16h	Get	Smart Meter Verification Algorithm State	U16	0Fh	See Table B-21
17h	Get	Smart Meter Verification Abort Code	U16	0Fh	See Table B-23
18h	Get	Smart Meter Verification State at Abort	U16	0Fh	See Table B-24

Attribute	Access	Name	Type	Trigger Byte WriteAttribute	Description
19h	Get	Smart Meter Verification Progress	U16	10h	% complete
1Ah	Get	Concentration units code	U8	13h	
1Bh	Get	Derived variable	U16	12h	See Table B-17
1Ch	Get	Active matrix	U16	12h	
1Dh	Get	Subnet communication status (RS-485 connection to transmitter)	U16	No trigger byte	0: Communications failure Any other value: Communications good

B.3.8 Output parameters (explicit data) for concentration measurement configuration

Class B1h, Instance 01h

Attribute	Access	Name	Type	Trigger byte write attribute	Description
01h	Get/Set	Standard or special mass flow rate unit	U16		See Table B-7
02h	Get/Set	Density unit	U16		See Table B-13
03h	Get/Set	Temperature unit	U16		See Table B-14
04h	Get/Set	Standard or special volume flow rate unit	U16		See Table B-10
05h	Get/Set	Pressure unit	U16		See Table B-15
06h	Get/Set	Zero time	U16		Seconds
07h	Get/Set	Zero value	Float		
08h	Get/Set	Output state during Smart Meter Verification	U16		0 = Last measured value 1 = Fault
09h	Get/Set	Smart Meter Verification Index	U16	11h	Smart Meter Verification test record. 0 = most recent ... 19 = oldest
0Ah	Get/Set	Trigger Byte-2	U8		
0Bh	Get/Set	Trigger Byte-3	U8		
0Ch	Get/Set	Trigger Byte-6	U8		

Attribute	Access	Name	Type	Trigger byte write attribute	Description
0Dh	Get/Set	Trigger Byte-9	U8		
0Eh	Get/Set	Trigger Byte-14	U8		
0Fh	Get/Set	Trigger Byte-15	U8		
10h	Get/Set	Trigger Byte-16	U8		
11h	Get/Set	Trigger Byte-24	U8		
12h	Get/Set	Trigger Byte-25	U8		
13h	Get/Set	Trigger Byte-17	U8		

B.3.9 Input assembly for petroleum measurement configuration

Byte	Access	Name	Type	Notes
0-3	Get	Mass flow rate	Float	
4-7	Get	Density	Float	
8-11	Get	Temperature	Float	
12-15	Get	Volume flow rate (liquid volume)	Float	
16-19	Get	Mass total	Float	
20-23	Get	Volume total	Float	
24-27	Get	Drive gain	Float	
28-29	Get	Status word	U16 or Word	<ul style="list-style-type: none"> For Model 1700 Analog, Model 2700 Analog, Model 1500 Analog, Model 2500, and all Series 3000 transmitters: SNS Status Word 1 (see Status Word 1) For MVD Direct Connect and 9739 MVD transmitters: SNS Status Word 2 (see Status Word 2)
30-31	Get	Status word	U16 or Word	<ul style="list-style-type: none"> For Model 1700 Analog, Model 2700 Analog, Model 1500 Analog, Model 2500, and all Series 3000 transmitters: SNS Status Word 2 (see Status Word 2) For MVD Direct Connect and 9739 MVD transmitters: SNS Status Word 1 (see Status Word 1)
32-35	Get	Temperature-corrected density	Float	

Byte	Access	Name	Type	Notes
36–39	Get	CTL	Float	
40–43	Get	Temperature-corrected volume flow	Float	
44–47	Get	Temperature-corrected volume total	Float	
48–51	Get	Temperature-corrected volume inventory	Float	
52–55	Get	Average temperature-corrected density	Float	
56–59	Get	Average temperature	Float	

B.3.10 Output assembly for petroleum measurement configuration

Byte	Access	Name	Type	Notes
0–3	Get/Set	External Temperature	Float	
4–7	Get/Set	External Pressure	Float	
8	Get/Set	Start/Stop Totals	Byte	0: Stop 1: Start
9	Get/Set	Reset All Process Totals	Byte	0: No action 1: Reset
10	Get/Set	Reset All Inventory Totals	Byte	0: No action 1: Reset
11	Get/Set	Start Zero	Byte	0: Abort or no action 1: Start
12–13	Get/Set	Start Smart Meter Verification	Word	See Table B-20

B.3.11 Input parameters (explicit data) for petroleum measurement configuration

To update any of these attribute values, the associated trigger byte must be toggled before reading the attribute value (executing the Get service). See [Output parameters \(explicit data\) for standard configuration](#) for more information on trigger bytes.

Class B0h, Instance 01h

Attribute	Access	Name	Type	Trigger Byte WriteAttribute	Description
01h	Get	Mass flow rate unit	U16	0Dh	See Table B-7
02h	Get	Density unit	U16	0Dh	See Table B-13
03h	Get	Temperature unit	U16	0Dh	See Table B-14
04h	Get	Volume flow rate unit	U16	0Dh	See Table B-9
05h	Get	Pressure unit	U16	0Dh	See Table B-15
06h	Get	Mass total/inventory unit	U16	0Dh	See Table B-8
07h	Get	Volume total/inventory unit	U16	0Dh	See Table B-10
08h	Get	Zero time	U16	0Eh	Seconds
09h	Get	Standard deviation of auto zero	Float	0Fh	
0Ah	Get	Present flow signal offset at zero flow	Float	0Fh	
0Bh	Get	Failed Zero Calibration Value	Float	0Fh	
0Ch	Get	Device Status Word 2	U16	10h	See Status Word 2
0Dh	Get	Device Status Word 3	U16	10h	See Status Word 3
0Eh	Get	Device Status Word 4	U16	10h	See Status Word 4
0Fh	Get	Device Status Word 5	U16	10h	See Status Word 5
10h	Get	Device Status Word 6	U16	10h	See Status Word 6
11h	Get	Device Status Word 7	U16	10h	See Status Word 7
12h	Get	External temperature input	Float	No trigger byte	
13h	Get	External pressure input	Float	No trigger byte	
14h	Get	Smart Meter Verification: Run Count	U16	11h	
15h	Get	Smart Meter Verification: Status	U16	11h	See Table B-22
16h	Get	Smart Meter Verification Algorithm State	U16	12h	See Table B-21
17h	Get	Smart Meter Verification Abort Code	U16	12h	See Table B-23
18h	Get	Smart Meter Verification State at Abort	U16	12h	See Table B-24

Attribute	Access	Name	Type	Trigger Byte WriteAttribute	Description
19h	Get	Smart Meter Verification Progress	U16	13h	% complete
1Ah	Get	API Table Type	U16	14h	See Table B-18
1Bh	Get	Reference temperature	Float	15h	
1Ch	Get	Thermal expansion coefficient (TEC)	Float	15h	
1Dh	Get	Subnet communication status (RS-485 connection to transmitter)	U16	No trigger byte	0: Communications failure Any other value: Communications good

B.3.12 Output parameters (explicit data) for petroleum measurement configuration

Class B1h, Instance 01h

Attribute	Access	Name	Type	Trigger byte write attribute	Description
01h	Get/Set	Standard or special mass flow rate unit	U16		See Table B-7
02h	Get/Set	Density unit	U16		See Table B-13
03h	Get/Set	Temperature unit	U16		See Table B-14
04h	Get/Set	Standard or special volume flow rate unit	U16		See Table B-10
05h	Get/Set	Pressure unit	U16		See Table B-15
06h	Get/Set	Zero time	U16		Seconds
07h	Get/Set	Zero value	Float		
08h	Get/Set	Output state during Smart Meter Verification	U16		0 = Last measured value 1 = Fault
09h	Get/Set	Smart Meter Verification Index	U16	16h	Smart Meter Verification test record. 0 = most recent ... 19 = oldest
0Ah		API Table Type	U16		See Table B-18
0Bh		Reference temperature	Float		

Attribute	Access	Name	Type	Trigger byte write attribute	Description
0Ch		Thermal expansion coefficient (TEC)	Float		
0Dh	Get/Set	Trigger Byte-2	U8		
0Eh	Get/Set	Trigger Byte-3	U8		
0Fh	Get/Set	Trigger Byte-6	U8		
10h	Get/Set	Trigger Byte-9	U8		
11h	Get/Set	Trigger Byte-14	U8		
12h	Get/Set	Trigger Byte-15	U8		
13h	Get/Set	Trigger Byte-16	U8		
14h	Get/Set	Trigger Byte-17	U8		
15h	Get/Set	Trigger Byte-20	U8		
16h	Get/Set	Trigger Byte-24	U8		

B.4 Get and Set services

The Get Attribute Single and Set Attribute Single services are used with many objects and attributes. Details of these two services are provided here

B.4.1 Get Attribute Single service

Table B-2: Get service arguments

Parameter name	Data type	Required	Parameter value	Notes
Attribute ID	USINT	Y	The attribute ID of the attribute to be read	No default

Table B-3: Get service response

Return value	Data type
Attribute value	The data type of the returned attribute

B.4.2 Set Attribute Single service

Table B-4: Set service arguments

Parameter name	Data type	Required	Parameter value	Notes
Attribute ID	USINT	Y	The attribute ID of the attribute to be set	No default

Table B-4: Set service arguments (continued)

Parameter name	Data type	Required	Parameter value	Notes
Attribute Value	The data type of the attribute being set	Y	The value to which the attribute will be set	No default

Table B-5: Set service response

Return value	Data type
No success response data	

B.5 Data types

Table B-6: Data types

Data type	Size (bytes)	Description	Range
BOOL	1	True/false represented as 0 = false and 1 = true	0, 1
SINT	1	8-bit signed integer	-128 to +127
USINT	1	8-bit unsigned integer	0 to 255
INT	2	16-bit signed integer	-32768 to +32767
UINT	2	16-bit unsigned integer	0 to 65535
DINT	4	32-bit signed integer	-2147483648 to +2147483647
UDINT	4	32-bit unsigned integer	0 to 4294967296
REAL	4	IEEE single-precision floating-point	-3.8E38 to +3.8E38
DREAL	8	IEEE double-precision floating-point	
ENGUNITS	1	Enumerated value representing an engineering unit of measure	4096 to 65535
BYTE	1	8-bit bitfield	N/A
SHORT_STRING	Up to 128 bytes	Character array where the first byte is the number of characters in the array, and the subsequent bytes contain the ASCII characters. This is not a NULL terminated string.	N/A

B.6 Codes and integer values

Table B-7: Mass flow measurement unit codes

Code	Description
70	Grams per second
71	Grams per minute
72	Grams per hour
73	Kilograms per second
74	Kilograms per minute
75	Kilograms per hour
76	Kilograms per day
77	Metric tons per minute
78	Metric tons per hour
79	Metric tons per day
80	Pounds per second
81	Pounds per minute
82	Pounds per hour
83	Pounds per day
84	Short tons (2000 pounds) per minute
85	Short tons (2000 pounds) per hour
86	Short tons (2000 pounds) per day
87	Long tons (2240 pounds) per hour
88	Long tons (2240 pounds) per day
253	Special

Table B-8: Mass totalizer and mass inventory measurement unit codes

Code	Description
60	Grams
61	Kilograms
62	Metric tons
63	Pounds
64	Short tons (2000 pounds)

Table B-8: Mass totalizer and mass inventory measurement unit codes (continued)

Code	Description
65	Long tons (2240 pounds)
253	Special

Table B-9: Liquid volume flow measurement unit codes

Code	Description
15	Cubic feet per minute
16	U.S. gallons per minute
17	Liters per minute
18	Imperial gallons per minute
19	Cubic meters per hour
22	U.S. gallons per second
23	Million U.S. gallons per day
24	Liters per second
25	Million liters per day
26	Cubic feet per second
27	Cubic feet per day
28	Cubic meters per second
29	Cubic meters per day
30	Imperial gallons per hour
31	Imperial gallons per day
130	Cubic feet per hour
131	Cubic meters per minute
132	Barrels per second ⁽¹⁾
133	Barrels per minute ⁽¹⁾
134	Barrels per hour ⁽¹⁾
135	Barrels per day ⁽¹⁾
136	U.S. gallons per hour
137	Imperial gallons per second
138	Liters per hour
170	Beer barrels per second ⁽²⁾

Table B-9: Liquid volume flow measurement unit codes (continued)

Code	Description
171	Beer barrels per minute ⁽²⁾
172	Beer barrels per hour ⁽²⁾
173	Baeer brrels per day ⁽²⁾
235	U.S. gallons per day
253	Special

(1) Unit based on oil barrels (42 U.S. gallons).

(2) Unit based on beer barrels (31 U.S. gallons). Not available with the standrad core processor.

Table B-10: Liquid volume totalizer and liquid volume inventory measurement unit codes

Code	Description
40	U.S. gallons
41	Liters
42	Imperial gallons
43	Cubic meters
46	Barrels ⁽¹⁾
112	Cubic feet
170	Beer barrels ⁽²⁾
253	Special

(1) Unit based on oil barrels (42 U.S. gallons).

(2) Unit based on beer barrels (31 U.S. gallons). Not available with the standrad core processor.

Table B-11: Gas standard volume flow measurement unit codes

Code	Description
121	Normal cubic meters per hour
122	Normal liters per hour
123	Standard cubic feet per minute
174	Normal liters per day
175	Normal liters per minute
176	Normal liters per second
177	Standard liters per day
178	Standard liters per hour

Table B-11: Gas standard volume flow measurement unit codes (continued)

Code	Description
179	Standard liters per minute
180	Standard liters per second
181	Normal cubic meters per day
182	Normal cubic meters per minute
183	Normal cubic meters per second
184	Standard cubic feet per day
185	Standard cubic feet per hour
186	Standard cubic feet per second
187	Standard cubic meters per day
188	Standard cubic meters per hour
189	Standard cubic meters per minute
190	Standard cubic meters per second
253	Special

Table B-12: Gas standard volume totalizer and inventory measurement unit codes

Code	Description
166	Normal cubic meters
167	Normal liters
168	Standard cubic feet
171	Standard liters
172	Standard cubic meters
253	Special

Table B-13: Density measurement unit codes

Code	Description
90	Specific gravity unit (not temperature corrected)
91	Grams per cubic centimeter
92	Kilograms per cubic meter
93	Pounds per U.S. gallon
94	Pounds per cubic foot

Table B-13: Density measurement unit codes (continued)

Code	Description
95	Grams per millileter
96	Kilograms per liter
97	Grams per liter
98	Pounds per cubic inch
99	Short tons per cubic yard
104	Degrees API

Table B-14: Temperature measurement unit codes

Code	Description
32	Degrees Celsius
33	Degrees Fahrenheit
34	Degrees Rankine
35	Kelvin

Table B-15: Pressure and differential pressure measurement unit codes

Code	Description
1	Inches water @ 68 °F
2	Inches mercury @ 0 °C
3	Feet water @ 68 °F
4	Millimeters water @ 68 °F
5	Millimeters mercury @ 0 °C
6	Pounds per square inch
7	Bar
8	Millibar
9	Grams per square centimeter
10	Kilograms per square centimeter
11	Pascals
12	Kilopascals
13	Torr @ 0 °C
14	Atmospheres

Table B-15: Pressure and differential pressure measurement unit codes (continued)

Code	Description
145	Inches water @ 60 °F ⁽¹⁾
237	Megapascals ⁽¹⁾
238	Inches water @ 4 °C ⁽¹⁾
239	Millimeters water @ 4 °C ⁽¹⁾

(1) Not available with the standard core processor.

Table B-16: Concentration measurement unit codes

Code	Description
100	Degrees Twaddell
101	Degrees Brix
102	Degrees Baume (heavy)
103	Degrees Baume (light)
105	% solids per weight (% mass)
106	% solids per volume (% volume)
107	Degrees Balling
108	Proof per volume
109	Proof per mass
160	Degrees Plato
253	Special (use with all systems that include an enhanced core processor)
255	Special (use with all systems that include a standard core processor)

Table B-17: Concentration measurement derived variable codes

Code	Description
0	None
256	Density at reference
512	Specific gravity
768	Mass concentration (Density)
1024	Mass concentration (Specific gravity)
1280	Volume concentration (Density)
1536	Volume concentration (Specific gravity)

Table B-17: Concentration measurement derived variable codes (continued)

Code	Description
1792	Concentration (Density)
2048	Concentration (Specific gravity)

Table B-18: API Table Type codes

Code	Description
17	Table 5A
18	Table 5B
19	Table 5D
36	Table 6C
49	Table 23A
50	Table 23B
51	Table 23D
68	Table 24C
81	Table 53A
82	Table 53B
83	Table 53D
100	Table 54C

Table B-19: Fixed output codes for Smart Meter Verification

Value	Description
0	Last measured value
1	Fault value

Table B-20: Enable Smart Meter Verification

Code	Description
1	Enable with fixed output (see Table B-19)
5	Abort
6	Enable with continuous measurement

Table B-21: Smart Meter Verification algorithm state

Value	Description
0	Inactive
1	Performing startup checks
2	Cutting drive setpoint
4	Initializing filters
6	Setting test tones
7	Ramping test tones
8	Checking drive stability
9	Setting drive voltage measurement
10	Verifying drive voltage
11	Resetting DAQ/MUX
12	Setting current calibration
13	Calibrating current amplitude
14	Resetting DAQ/MUX
15	Calculating system parameters
16	Test completed
17	Disabling test tones
18	Restoring normal drive setpoint

Table B-22: Smart Meter Verification status

Bit number	Status
0	State at abort
1	
2	
3	
4	Abort code
5	
6	
7	Result: 0=Pass 1=Fail

Table B-23: Smart Meter Verification abort codes

Abort code	Description	Suggested action
1	User-initiated abort	None required. Wait for 15 seconds before starting another test.
3	Frequency drift	Ensure that temperature, flow, and density are stable, and rerun the test.
5	High drive gain	Ensure that flow is stable, minimize entrained gas, and rerun the test.
8	Unstable flow	Enter that flow is stable and rerun the test.
13	No factory reference data for meter verification test performed on air	Contact Micro Motion customer service and provide the abort code.
14	No factory reference data for meter verification test performed on water	Contact Micro Motion customer service and provide the abort code.
15	No configuration data for meter verification	Contact Micro Motion customer service and provide the abort code.
Other	General abort.	Repeat the test. If the test aborts again, contact Micro Motion customer service and provide the abort code.

Table B-24: Smart Meter Verification state at abort

Value	Description
0	Inactive
1	In progress
15	Debug mode
16	Measurement completed

B.7 Status words

B.7.1 Status Word 1

Bit number	Status description
0	Core EEPROM Checksum Error (Config, Powerdown, Program)
1	Core RAM Test Error
2	Real-Time Interrupt Failure
3	Sensor Failure (A003)
4	Temperature Sensor Out-of-Range (A004)

Bit number	Status description
5	Calibration Failure (Zero, Density, Temperature)
6	Other Failure
7	Transmitter Initializing/Warming Up (Low Power Fault)
8	Primary Variable Out-Of-Limits
9	Non-Primary Variable Out-Of-Limits
10	Simulation Mode Active (A132)
11	Undefined
12	Watchdog Error
13	Cold Start (HART bit)
14	Transmitter Configuration Changed (HART bit)
15	Fault (Failure has occurred which affects accuracy)

B.7.2 Status Word 2

Bit number	Status description
0	Primary mA Output Saturated (A100)
1	Secondary mA Output Saturated (A113)
2	Primary mA Output Fixed (A101)
3	Secondary mA Output Fixed (A114)
4	Density Outside Limits (A8)
5	Drive Over-Range (A102)
6	PIC/Daughterboard Communication Failure (A029)
7	External Input Failure (A115)
8	Core EEPROM Checksum Error (Config, Powerdown, Program) (A001)
9	Core RAM Error (A002)
10	Sensor Not Responding (No Tube Interrupt) (A003)
11	Temperature Sensor Out-of-Range (A004)
12	Input Over-Range (A005)
13	Frequency Output Saturated (A110)
14	Transmitter Not Characterized (Flowcal or Sensor Type) (A006)
15	Real-Time Interrupt Failure (A007)

B.7.3 Status Word 3

Bit number	Status description
0	Burst Mode Enabled (A106) (AI Simulate enabled on Model 2700 transmitters with PROFIBUS-PA, firmware v2.2)
1	Power Reset Occurred (A107)
2	Transmitter Initializing/Warming Up (Low Power Fault) (A009)
3	Sensor/Xmtr Communication Failure (A028)
4	Paper Out (A130)
5	Event #2 Triggered (A108) (basic event model)
6	Event #1 Triggered (A109) (basic event model)
7	Sensor/Xmtr Communication Failure (A026)
8	Calibration Failure (Autozero, Density, Temperature) (A010)
9	Excess Calibration Correction, Zero too Low (A011)
10	Excess Calibration Correction, Zero too High (A012)
11	Process Too Noisy to Perform Auto Zero (A013)
12	Transmitter Failed (A014)
13	Data Loss Possible (Totals+Inventories Questionable) (A103)
14	Calibration-In-Progress (Autozero, Density, Temperature) (A104)
15	Slug Flow (A105)

B.7.4 Status Word 4

Bit number	Status description
0	Petroleum Measurement: Temperature Outside Standard Range (A116)
1	Petroleum Measurement: Line Density Outside Standard Range (A117)
2	Line RTD Temperature Out-Of-Range (A016)
3	Case/Meter RTD Temperature Out-Of-Range (A017)
4	Flow Direction (0=Forward/Zero, 1=Reverse)
5	Factory Configuration Data Is Invalid
6	Concentration Measurement: Unable to fit curve data (A120)
7	Last Measured Value Override Active
8	Enhanced Density Extrapolation Alarm (A121)

Bit number	Status description
9	Cal Factors Unentered (Flocal Mandatory) (A020)
10	1000/2000/3000 EEPROM Checksum Error (A018)
11	1000/2000/3000 RAM Test Error (A019)
12	Unrecognized/Unentered Sensor Type (K1 Mandatory) (A021)
13	Core configuration database corrupt (A022)
14	Core powerdown totals corrupt (A023)
15	Core program corrupt (A024)

B.7.5 Status Word 5

Bit number	Status description
0	Core Protected Boot Sector Fault (invalid/corrupt application) (A025)
1	For Series 1000/2000/3000: Software Upgrade Recommended (A112) For Enhanced Core Processors: Data Bad (Fault exists and LMV timer has expired)
2	Frequency Output Fixed (A111)
3	Primary mA Readback Failure
4	Discrete Output 1 Status (0=OFF, 1=ON)
5	Discrete Output 2 Status (0=OFF, 1=ON)
6	Density Calibration in Progress (D3)
7	Density Calibration in Progress (D4)
8	DO3 Status (0=OFF, 1=ON)
9	DO4 Status (0=OFF, 1=ON)
10	Temperature Calibration-in-Progress (Slope)
11	Temperature Calibration-in-Progress (Offset)
12	Density Calibration in Progress (Flowing Density)
13	Density Calibration in Progress (D2)
14	Density Calibration in Progress (D1)
15	Zero Calibration in Progress

B.7.6 Status Word 6

Bit number	Status description
0	Discrete Input 1 Status (0=OFF, 1=ON) Weights and Measures: Database Checksum for Core Processors Only
1	Discrete Input 2 Status (0=OFF, 1=ON) Weights and Measures: Database Checksum for Core Processors Only
2	Discrete Output 1 Fixed (A118) Weights and Measures: Database Checksum for Core Processors Only
3	Discrete Output 2 Fixed (A119) Weights and Measures: Database Checksum for Core Processors Only
4	Discrete Output 3 Fixed (A122) Weights and Measures: Database Checksum for Core Processors Only
5	Discrete Output 4 Fixed (A123) Weights and Measures: Database Checksum for Core Processors Only
6	Security Breach (A27) Weights and Measures: Database Checksum for Core Processors Only
7	Frequency Input Saturated (A124) Weights and Measures: Database Checksum for Core Processors Only
8	Discrete Event 1 Status Discrete Batch: Batch Timeout (A125) for 1500 and Series 3000 Only
9	Discrete Event 2 Status Discrete Batch: Batching for 1500 and Series 3000 Only
10	Discrete Event 3 Status Discrete Batch: Batch End Warn for Series 3000 Only
11	Discrete Event 4 Status Discrete Batch: Batch Overrun (A126) for Series 3000 Only
12	Discrete Event 5 Status Discrete Batch: Batch Pump for Series 3000 Only
13	Discrete Batch: Batch Primary Valve for 1500 and Series 3000 Only
14	Discrete Batch: Batch Secondary Valve for 1500 and Series 3000 Only
15	Incorrect Board Type (A30) Discrete Batch: Start Not Okay for 1500 and Series 3000 Only

Note

Not all alarms are applicable to all transmitters. For more information, see the transmitter configuration manual for your transmitter.

B.7.7 Status Word 7

Bit number	Status description
0	K1/FCF Combination Unrecognized
1	Warming Up
2	Low Power (A031)
3	Tube Not Full (A033)
4	Smart Meter Verification / Outputs in fault (A032)
5	Smart Meter Verification / Outputs at last value (A131)
6	PIC UI EEPROM Error (A133)
7	NVM Initialized (transmitter)
8	Power Outage (A136)
9	NOC Measurements Paused (A137)
10	TBR Active (A138)
11	External Water Cut Out of Range (A139)
12	TMR Active (A140)
13	One or more DDC Triggers Completed (A141)
14	Smart Meter Verification failed (A34)
15	Smart Meter Verification aborted (A35)

C Specifications

Physical specifications

Physical specifications	Description
Housing	Plastic housing with snap-on connection to DIN rail Protection class: IP20
Dimensions	4.72 in x 2.95 in x 1.06" LxWxH (120 mm x 75mm x 27mm)

Electrical specifications

Electrical specifications	Description
Power supply	24 V \pm 10%
Power consumption	Maximum: 280mA on 24 V Typical: 100mA

Environmental specifications

Environmental specifications	Description
Relative humidity	5 to 95% non-condensing
Temperature	Operating: 32 °F (0.0 °C) to 131 °F (55.0 °C) Ambient: -13 °F (-25.0 °C) to 185 °F (85.0 °C)

EMC compliance (CE) specifications

Complies with EMC directive 2004/108/EC.

EN 61001-6-4 (2007)	Emission standard for industrial environment	EN 55016-2-3 (2006) Class A
EN 61000-6-2 (2005)	Immunity standard for industrial environment	EN 61000-4-2 (2009) EN 61000-4-3 (2006) EN 61000-4-4 (2004) EN 61000-4-5 (2005) EN 61000-4-6 (2007)

UL/c-UL compliance specifications

The certification has been documented by UL in file E214107.

Galvanic isolation on Modbus serial interface

EN 60950-1 (2001)	Pollution Degree 2
	Material Group IIIb
	250 VRMS or 250 VDC: Working voltage
	500 V: Secondary circuit transient rating



MMI-20019808
Rev. AE
2019

Micro Motion Inc. USA

Worldwide Headquarters
7070 Winchester Circle
Boulder, Colorado USA 80301
T +1 303-527-5200
T +1 800-522-6277
F +1 303-530-8459
www.emerson.com

Micro Motion Europe

Emerson Automation Solutions
Neonstraat 1
6718 WX Ede
The Netherlands
T +31 (0) 70 413 6666
F +31 (0) 318 495 556
www.micromotion.nl

Micro Motion Asia

Emerson Automation Solutions
1 Pandan Crescent
Singapore 128461
Republic of Singapore
T +65 6363-7766
F +65 6770-8003

Micro Motion United Kingdom

Emerson Automation Solutions
Emerson Process Management Limited
Horsfield Way
Bredbury Industrial Estate
Stockport SK6 2SU U.K.
T +44 0870 240 1978
F +44 0800 966 181

©2019 Micro Motion, Inc. All rights reserved.

The Emerson logo is a trademark and service mark of Emerson Electric Co. Micro Motion, ELITE, ProLink, MVD and MVD Direct Connect marks are marks of one of the Emerson Automation Solutions family of companies. All other marks are property of their respective owners.

MICRO MOTION™

