

FEATURES

- Compact aluminium flanged bodied dual flow valves for petrol vending applications
- Valve offers three flow positions, i.e. full flow, low flow, and shut off
- Minimum operating differential pressure 0,35 bar
- Explosion proof operators, intended for use in potential explosive areas, according to Directive ATEX 94/9/EC
- Easy electrical installation by means of the moulded-in supply cable, standard length 2 meter
- ASCO Numatics components satisfy all relevant EC directives

GENERAL

Differential pressure 0,35 - 3,5 bar [1 bar = 100kPa]
Ambient temperature range AC: -40 to +65°C
 DC: -40 to +40°C

fluids (*)	temperature range (TS)	seal materials (*)
Petrol & Liquid fuels	-40 to +40°C	FPM (fluoroelastomer) / VMQ (silicone)

MATERIALS IN CONTACT WITH FLUID

(*) Ensure that the compatibility of the fluids in contact with the materials is verified

Body	Aluminium
Core tube	Stainless steel
Core and plugnut	Stainless steel
Springs	Stainless steel
Seat	Aluminium
Sealing	FPM / VMQ
Disc & O-Rings	FPM
Diaphragm Support	POM
Shading Ring (AC only)	Copper

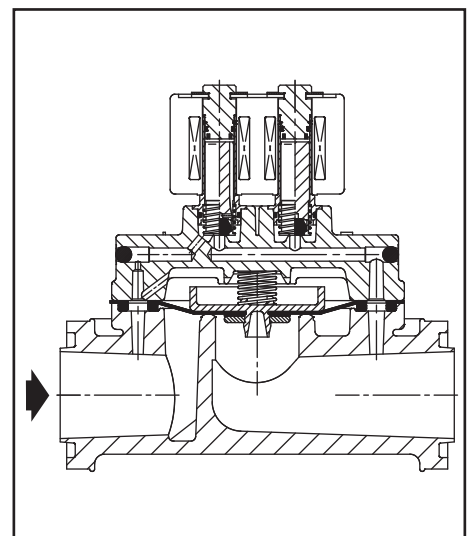

ELECTRICAL CHARACTERISTICS

Coil insulation class F
Electrical safety IEC 335
Standard voltages DC (=) 24V - 48V;
 AC (~) 24V - 48V - 115V - 230V / 50 Hz

prefix option	power ratings		operator ambient temperature range (TS) (C°)	safety code	electrical enclosure protection (EN 60529)	replacement coil		type ⁽¹⁾
	holding ~ (W)	hot/cold = (W)				~	=	
	230V/50/60 Hz	24V/DC						
PV	4,0	5,0 / 6,9	-40 to +65	II 2 G Ex mb II T3	moulded IP67	-	⁽²⁾	01

⁽¹⁾ Refer to the dimensional drawings on page 12

⁽²⁾ Multiple coils kits available under ATEX, contact us
 - Not available

SPECIFICATIONS

pipe size	orifice size (mm)	flow coefficient Kv				operating pressure differential (bar)			prefix optional solenoids *						basic catalogue number
		Low (m³/h) (l/min)		High (m³/h) (l/min)		min	max. PS ~ =		NEMA 7&9 EF	ATEX / IECEx			IP65 SC		
		Ex d	Ex e mb	Ex mb	EEx nA										
T	(mm)	(m³/h)	(l/min)	(m³/h)	(l/min)	min	~	=	EF	NF	EM	PV	ZN	SC	T292B025
NC - Normally closed															
1	25	0,12	2,0	11,5	192	0,35	3,5	3,5	-	-	-	●	-	-	T292B025

● Available feature
 - Not available

* For description of solenoids see pages 31-40

INSTALLATION

- The valves can be mounted in any position without affecting operation
- Pipe connection identifiers: T = flanged body
- Installation/maintenance instructions are included with each valve
- PV solenoids have a standard cable length of 2 meters. Other lengths in full meters are available on request

DIMENSIONS (mm), WEIGHT (kg)



TYPE 01

Prefix "PV" Solenoid
 Epoxy encapsulated
 EN-IEC 60079-0, 60079-18, 61241-0, 61241-18
 II 2 G/D Ex mb II / Ex mD
 IP67

T292B025

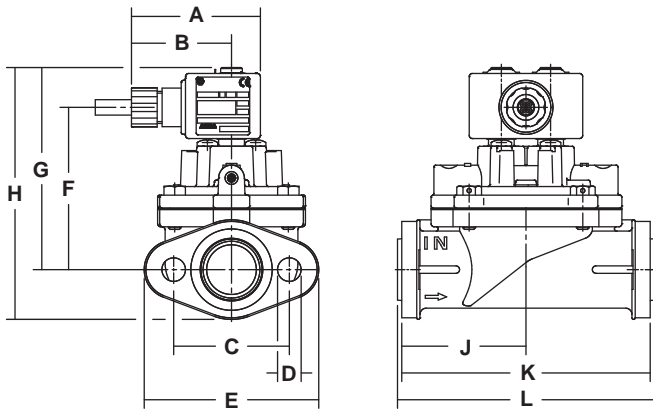

type	AC/DC	prefix option	catalogue number	spare parts kits	A	B	C	D	E	F	G	H	J	K	L	weight
01	~/=	PV	T292B025	320180 / 320196	60	47	54	Ø11	82	76	94	118	58	116	120	1,0 Kg