

Fisher™ CAV4 Control Valve

The Fisher CAV4 control valve with Cavitol™ IV trim is designed specifically for liquid applications, such as boiler feedwater recirculation, where pressure drops are above 207 bar (3000 psi) and cavitation is a serious problem. The CAV4 valve is available in a broad range of valve body sizes and styles, including NPS 2 through 6 angle, globe, and offset globe.

The CAV4 valve's various valve plug constructions (figure 1) provide temperature capabilities through 417°C (800°F). The seal ring construction is used where temperatures are equal to or lower than 232°C (600°F) (see figure 5), and both the stem-balanced and the piston ring constructions are used with temperatures up to 417°C (800°F). In addition, the CAV4 valve is offered with either a separable seat ring for moderate temperature (up to 232°C [450°F]) applications or with an integral seat cage for high-temperature (up to 417°C [800°F]) applications. The NPS 3 is available only with a clamped-in lower cage and replaceable seat ring.

Features

- **Cavitation Decreased**—A properly sized CAV4 valve with Cavitol IV trim decreases cavitation and its resultant damage and noise.
- **Long Trim Life**—Pressure-staging design and separation of shutoff and throttling locations decrease clearance-flow erosion. Hardened trim materials result in improved wear resistance.
- **Tight Shutoff**—Soft metal-to-metal seat provides tight shutoff without the need for periodic lapping. The anti-extrusion ring provides an enhanced valve plug seal.
- **TSO (Tight Shutoff) Trim**—Valves with TSO trim (figure 1) are factory tested to a more stringent Emerson Automation Solutions test requirement of no leakage at time of shipment using ANSI/FCI Class V procedures.

(continued on page 3)

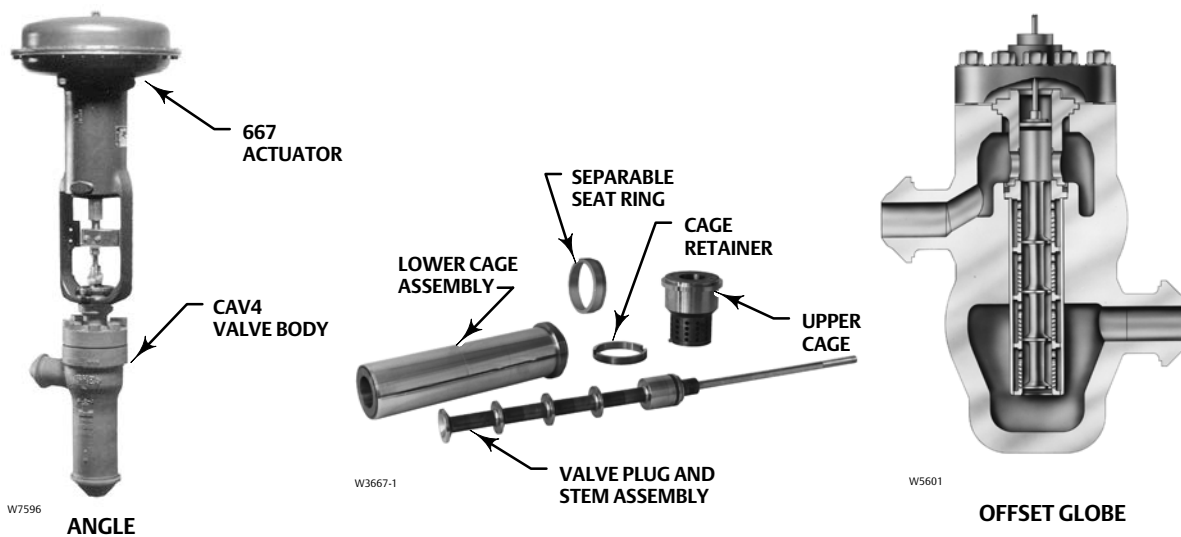

Fisher 657-CAV4 Control Valve Assembly with Cavitol IV Trim

Specifications

Available Configurations and Valve Body Sizes

Common Characteristics: CAV4 angle, globe, or offset globe valve with four-stage Cavitrol IV trim including soft metal-to-metal seat. Valve plug action is push-down-to-close
Seal Ring Construction: ■ NPS 2, ■ 3, ■ 4, or ■ 6 valve body with pressure-balanced valve plug and spring-loaded PTFE seal ring. For use in low-temperature applications
Stem-Balanced Construction: ■ NPS 2 or ■ 4 valve body with stem-balanced valve plug (valve stem diameter—for that portion of stem that passes through bonnet—is equal to nominal port diameter). For use in high-temperature applications
Piston Ring Construction: NPS 6 valve body with pressure-balanced valve plug and five graphite piston rings. For use in high-temperature applications

End Connection Style⁽¹⁾

Buttwelding Ends: All buttwelding end schedules per ASME B16.25 that are compatible with ASME B16.34 valve body rating
Raised-Face or Ring-Type Joint Flanged Ends: Inlet connection is CL2500 flange per B16.5. Outlet connection mates with CL2500 flange and has tapped bolt holes

Maximum Inlet Pressure and Temperatures⁽¹⁾⁽²⁾

Consistent with applicable CL2500 pressure temperature ratings per ASME B16.34 unless limited by individual pressure drop limits shown in figure 5 or temperature limits shown in table 1

Maximum Pressure Drop⁽²⁾

See figure 5

Material Temperature Capabilities⁽²⁾

Seal Ring Construction: 18 to 232°C (0 to 450°F)
Stem-Balanced and Piston Ring Constructions: Up to

427°C (800°F) unless limited by selection of other parts (table 1)

Shutoff Classification

TSO (Tight Shutoff) Trim: Valves with TSO trim are factory tested to a more stringent Emerson Automation Solutions test requirement of no leakage at time of shipment using ANSI/FCI 70-2 and IEC 60534-4 Class V procedures.
Piston Ring Construction: Class IV per ANSI/FCI 70-2 and IEC 60534-4
All Others: Class VI per ANSI/FCI 70-2 and IEC 60534-4

Flow Direction

In through the side connection and out the bottom connection

Noise Levels

Because of cavitation elimination, noise is typically not a problem with Cavitrol IV trim. For virtually all applications, noise levels will be below 90 dBA. If more stringent noise specifications must be met, contact your [Emerson sales office](#) or Local Business Partner

Construction Materials

See table 1

Flow Characteristic

Linear

Maximum Flow Coefficients (C_v)

Linear: ■ NPS 2 valve, 8.25; ■ NPS 3 valve, 14.6; ■ NPS 4 valve, 21.9; ■ NPS 6 valve, 55.6
Characterized: ■ NPS 2 valve, 11.3; ■ NPS 3 valve, 24; ■ NPS 4 valve, 38.2; ■ NPS 6 valve, 89.1. Also see Fisher Catalog 12

- continued -

Contents

Features 1
 Specifications 2
 Principle of Operation 7
 Selection Guidelines 8
 Installation 9
 Ordering Information 10

Tables

Construction Materials and
 Temperature Capabilities 4
 Additional Specifications 5
 Additional Specifications for TSO Trim 5
 Dimensions 11

Specifications (continued)

Valve Recovery and Cavitation Coefficients

Recovery Coefficient

Linear: $K_m = 0.99$. Characterized: $K_m = 0.98$. This value defines the maximum allowable pressure drop that is effective in producing flow as shown in the following equation:

$$\Delta P_{\text{allowable}} = K_m (P_{1 \text{ (flowing)}} - r_c P_v)$$

Cavitation Coefficient

Linear and Characterized: $K_c = 1.0$. This value predicts the beginning of cavitation-related damage as shown in the following equation:

$$\Delta P_{\text{Cavitation}} = K_c (P_{1 \text{ (flowing)}} - P_v)$$

where,

$\Delta P_{\text{allowable}}$ = maximum allowable pressure drop that is effective in producing flow, bar (psi)

$P_{1 \text{ (flowing)}}$ = flowing inlet pressure, bar, absolute (psia)

r_c = critical pressure ratio from Catalog 12

P_v = vapor pressure of liquid at inlet temperature, bar, absolute (psia)

Port Diameters and Unbalance Area

See table 3

Minimum Seat Load Force

First refer to figure 6 to determine minimum seat load per inch of port circumference; then multiply that value by the port circumference from table 3

Valve Plug Travel

See table 3

Yoke Boss and Valve Stem Diameters

See table 3

Approximate Weight

See table 3

Options

- Flushing trim, two plates used in place of Cavtrol IV trim, to protect valve body surfaces and Cavtrol IV trim from damage during pipeline flushing:
- characterized cage; and
- driver for installation and removal of cage retainer
- ENVIRO-SEAL™ packing is available

1. PN (or other) ratings and end connections can usually be supplied; contact your [Emerson sales office](#) or Local Business Partner.
2. The pressure/temperature limits in this bulletin and any applicable linear limitation should not be exceeded.

Features (continued)

- **Efficient Operation**—Expanding flow area design takes advantage of the ability of the liquid to undergo a greater pressure drop in initial stages without cavitating. This results in a much lower inlet pressure to the final stage.
- **Characterization**—Special characterized cages are available to provide customer specified rangeability for specific system requirements.
- **Easy Maintenance**—Design reduces maintenance downtime by permitting quick disassembly with easy access to valve trim and valve plug seat. Separable seat ring for low temperature applications (at or below 232°C [450°F]) makes maintenance easier.

Table 1. Construction Materials and Temperature Capabilities

PART	MATERIALS		TEMPERATURE CAPABILITIES	
			°C	°F
Valve Body and Bonnet	Standard	WCC carbon steel casting	See figure 5	See figure 5
	Optional	WC9 alloy steel casting or C5		
Valve Plug	S44004 (440C stainless steel heat-treated)		-29 to 427	-20 to 800
Valve Stem	3/4 inch stem in NPS 4 body, S31600/S17400 (316/17-4PH) stainless steel		-101 to 427	-150 to 800
	All other stems, 316 stainless steel or S20910		-254 to 427	-425 to 800
Seat Ring	17-4/316 SST stainless steel		-29 to 232	-20 to 450
O-ring (separable seat ring construction for NPS 2, 4, & 6 only)	Ethylene propylene		-18 to 232	0 to 450
Upper Cage, Seat Ring Retainer, and Lower Cage Assembly	17-4/316 SST stainless steel (cages) and 17-4 H1075 SST stainless steel Cr Ct (retainer)		-29 to 427	-20 to 800
Valve Plug Seal Ring ⁽¹⁾	Spring-loaded PTFE seal		-18 to 232	0 to 450
Valve Plug Backup Ring ⁽¹⁾	S41600 (416 stainless steel)		-29 to 427	-20 to 800
Seal Ring Retainer ⁽¹⁾	S30200 (302 stainless steel)		-254 to 593	-425 to 1100
Piston Ring ⁽²⁾	Graphite (FMS 17F27)		-46 to 427	-50 to 800
Bonnet Gasket	Silver-plated N04400 nickel alloy		-254 to 593	-425 to 1100
Cage Gasket	316 stainless steel/graphite		-254 to 593	-425 to 1100
Metal Packing Box Parts	316 stainless steel		-254 to 593	-425 to 1100
Body-to-Bonnet Bolting	Studs, steel SA193-B7; nuts, steel SA194-2H		-29 to 427	-20 to 800
Packing	Standard	Spring-loaded PTFE V-ring	-46 to 232	-50 to 450
	Optional	PTFE-impregnated composition	-73 to 232	-100 to 450
		Laminated graphite/filament	-18 to 427	0 to 800

1. For only seal ring construction.
2. For only 6-inch piston ring construction.

Table 2. Trim Descriptions

TRIM DESIGNATION	VALVE SIZE, NPS	VALVE PLUG	CAGE	SEAT RING	VALVE BODY MATERIAL	OPERATING TEMPERATURE	
						°C	°F
Standard Trim							
70	2 ⁽¹⁾ , 4, and 6	S44004	S17400 H1075	S17400/S31600	C5 WCC WC9	-29 to 232	-20 to 450
72	2 ⁽¹⁾ and 4	N07718/CoCr-A Seat/Guide	S17400/S31600	Not Required	C5 WCC WC9	-101 to 165	-150 to 330
72	6	N07718/CoCr-A Seat/Guide	S17400/S31600	Not Required	C5 WCC WC9	-101 to 93	-150 to 200
73	3	S44004	S17400 H1075	S31600	C5 WCC WC9	-29 to 232	-20 to 450
Tight Shutoff Trim							
74	2 ⁽¹⁾ , 3, and 4	S44004/S41600	S17400 H1075	S44004	C5 WCC WC9	0 to 232	32 to 450
High Temperature Trim							
75	2 ⁽¹⁾ , 4, and 6	S44004	S17400/S31600	Not Required	C5 WCC WC9	232 to 426	450 to 800

1. NPS 2 Angle Body only.

Table 3. Additional Valve Body Specifications

VALVE SIZE, NPS	VALVE STEM DIAMETER		YOKE BOSS DIAMETER		TRAVEL		PORT DIAMETER		PORT CIRCUMFERENCE		UNBALANCE AREA ⁽¹⁾		APPROXIMATE WEIGHT	
	mm	Inch	mm	Inch	mm	Inch	mm	Inch	mm	Inch	cm ²	Inch ²	Kg	Lb
2	19.0	3/4	91	3-9/16	38	1.5	38.1	1.5	119.6	4.71	4.3	0.17	167	369
	38.1	1-1/2 ⁽²⁾	127	5									182	401
3	19.0	3/4	91	3-9/16	51	2	55.6	2.1875	174.5	6.87	6.6	0.26	301	664
4	19.0	3/4	91	3-9/16	64	2.5	69.9	2.75	219.4	8.64	8.1	0.32	532	1172
	25.4	1	127	5									532	1172
	69.8	2-3/4 ⁽³⁾	178	7									554	1222
6	31.7	1-1/4	127	5 and 5H	102	4	111.1	4.375	349.2	13.75	12.9	0.51	1512	3334

1. For seal ring and piston ring constructions. For stem-balanced construction, use port area of 11.4 cm² (1.77 inch²) for NPS 2 valve and 38.3 cm² (5.94 inch²) for NPS 4 valve.
2. Stem-balanced construction has 1-1/4 inch valve stem connection.
3. Stem-balanced construction has 2-inch valve stem connection.

Table 4. Additional Valve Body Specifications for TSO (Tight Shutoff) Trim

VALVE SIZE, NPS	MAXIMUM TRAVEL		YOKE BOSS SIZE ⁽¹⁾		PORT DIAMETER				PORT CIRCUMFERENCE		C _v REDUCTION AT 100% TRAVEL ⁽²⁾
					Nominal		Actual TSO				
	mm	Inch	mm	Inch	mm	Inch	mm	Inch	mm	Inch	
2	38	1.5	91 127	3-9/16 5	38.1	1.5	38.1	1.5	119.6	4.71	0%
3	50.8	2	91	3-9/16	55.6	2.1875	55.6	2.1875	174.5	6.87	0%
4	64	2.5	91 127	3-9/16 5	69.9	2.75	69.9	2.75	219.4	8.64	0%

1. Consult the factory for larger yoke boss sizes.
2. This column lists the percent reduction of published maximum C_v of the trim listed in the TRIM column.

Figure 1. Sectional View of Fisher CAV4 Valve Body with Cavtrol IV Trim

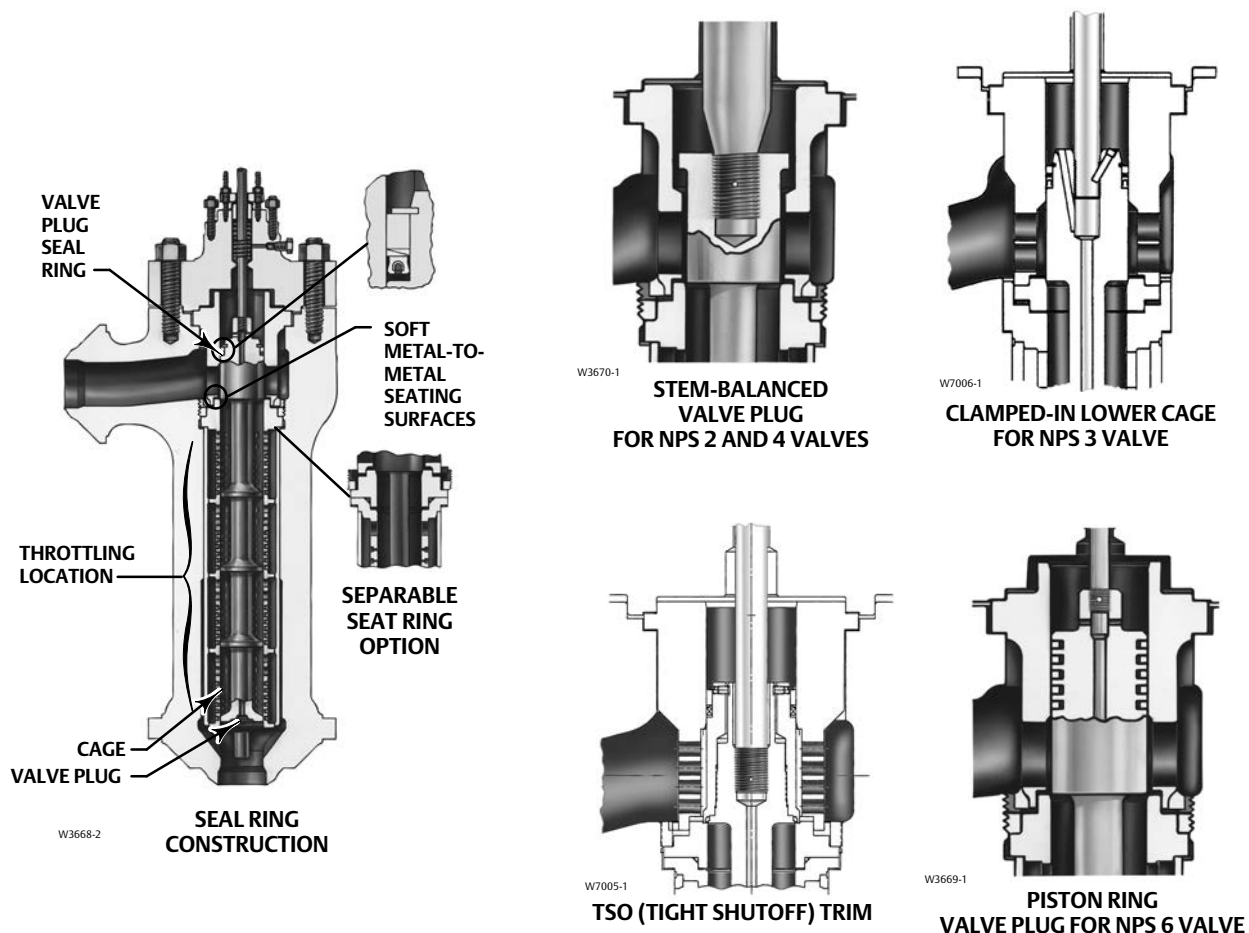

Figure 2. Standard Cage-Style Anti-cavitation Trim

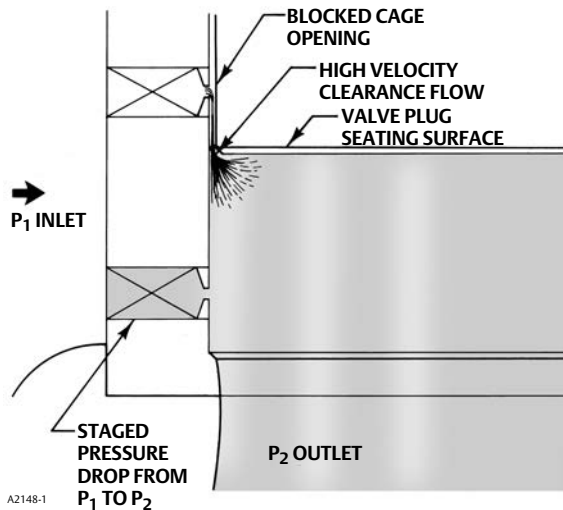
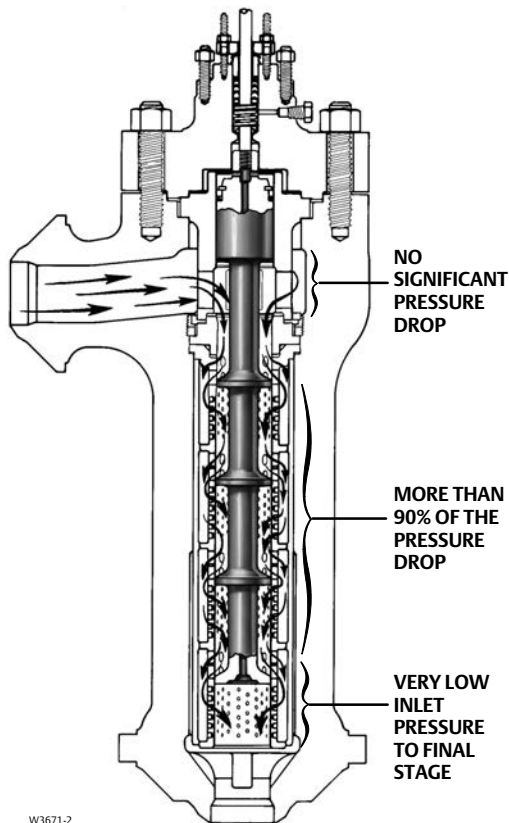

Figure 3. Cavitrol IV Trim Operation



Principle of Operation

The advantage of the CAV4 valve with Cavitrol IV trim is a result of the following three technological advancements not found in any other anti-cavitation control valve.

1. All clearance flow subjected to staged pressure drop.
2. Separation of shutoff and throttling locations.
3. An expanding flow area design.

Although linear cage-style anti-cavitation trims can successfully handle pressure drops to about 207 bar (3000 psi), they are not effective above 207 bar (3000 psi) especially when the valve plug is off the seat and throttling. As shown in figure 2, the linear cage openings below the valve plug seating surface are open to fluid flow and are staging the pressure drop from P_1 to P_2 as designed. However, the cage openings above the valve plug seating surface are nearly blocked by the valve plug. Even though a small clearance passage between the cage and the valve plug does exist, the fluid flow rate through this small clearance passage is so small that the cage is ineffective in staging the pressure drop. Consequently, the clearance flow pressure drop from P_1 to P_2 occurs between the valve plug surface blocking the cage opening and the seating surface of the valve plug. The resultant cavitation and erosive flow across the seat damages the valve plug seating surface. Even with valve plug/cage diametrical clearances as small as 0.20 mm (0.008 inch), this clearance flow damage still occurs and becomes worse with higher pressure drops.

The CAV4 valve with Cavitrol IV trim addresses this clearance flow issue by not taking any significant pressure drop until the fluid is downstream of the seating surfaces (figure 3). As the flow then passes from stage to stage, even the clearance flow is subjected to a staged pressure drop. Therefore, unlike the linear cage-style anti-cavitation trims, there are no flowing conditions where pressure can go directly from P_1 to P_2 .

In the Cavitrol IV trim design, trim life is lengthened by the separation of the shutoff and throttling locations. Just as all significant pressure drop is taken downstream of the shutoff seating surfaces, all significant throttling action occurs as the liquid passes through the four sets of holes downstream of the shutoff seating surfaces. As a result, the seating surfaces are normally not worn away by throttling control action (unless throttling at very nearly closed for a long time). Also, the throttling areas are not

required to have the superior surface condition otherwise needed by seating surfaces for tight shutoff.

In conventional staged-trim designs, cavitation usually does not exist until the final stage. Figure 4 illustrates why this happens. As shown, the greater the pressure drop through the final stage, the lower the vena contracta pressure (P_{vc}). If P_{vc} is less than or equal to P_v , and P_2 is greater than P_v , then cavitation will result.

The CAV4 valve avoids this by means of its unique expanding flow area design. Each of the four Cavitrol IV trim stages has a successively larger flow area. The result is very efficient operation because more than 90 percent of the overall pressure drop is taken in the first three stages where there is little danger of bubble formation. Consequently, a relatively low inlet pressure to the final stage is achieved. Figure 4 also compares the pressure drop pattern through the four stages in the expanding area Cavitrol IV design with a pattern representing a six-stage trim design with each stage taking an equal portion of the total pressure drop. As can be seen, the inlet pressure to the last stage of Cavitrol IV trim is always less than the inlet pressure to the sixth stage of an equal-drop cage. Therefore the P_{vc} of the Cavitrol IV cage remains higher than the P_{vc} of an equal-drop cage. If the pressure drops were all equivalent to that of the last stage in Cavitrol IV trim, 11 stages would be required in the equal-drop trim.

Figure 4. Staged Pressure Drop Patterns

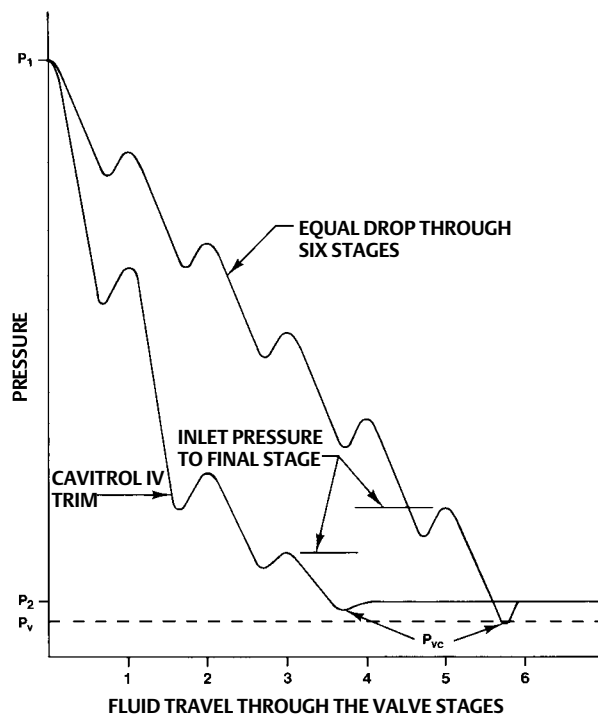

A2149-1

Selection Guidelines

To determine if the CAV4 valve with Cavitrol IV trim should be used, first calculate the application ratio, A_r , and then apply one of the three conditions below:

$$A_1 = (\Delta P_{Flow}) / (P_1 - P_v)$$

where,

ΔP_{Flow} = differential between flowing inlet and flowing outlet pressure, bar, absolute (psia)

P_1 =inlet pressure, bar, absolute (psia)

P_v =vapor pressure of process liquid at inlet temperature, bar, absolute (psia)

1. If the application ratio is less than 1.0 and the maximum pressure drop is between 206 bar [3000 psi] and 414 bar [6000 psi] for linear trim (or between 206 bar [3000 psi] and 310 bar [4500 psi] for approximate linear trim), service is potentially cavitating and a CAV4 valve with Cavitrol IV trim should be selected.

2. If the application ratio is equal to or greater than 1.0 and the maximum pressure drop is less than or equal to 206 bar (3000 psi), service is flashing and the CAV4 body with Cavitrol IV trim should be selected.

3. If the application ratio is less than 1.0 and the maximum pressure drop is less than 206 bar (3000 psi), then refer to other anti-cavitation products.

Refer to table 1 and figure 5 for trim material selection.

Figure 5. Pressure Drop/Temperature Capabilities

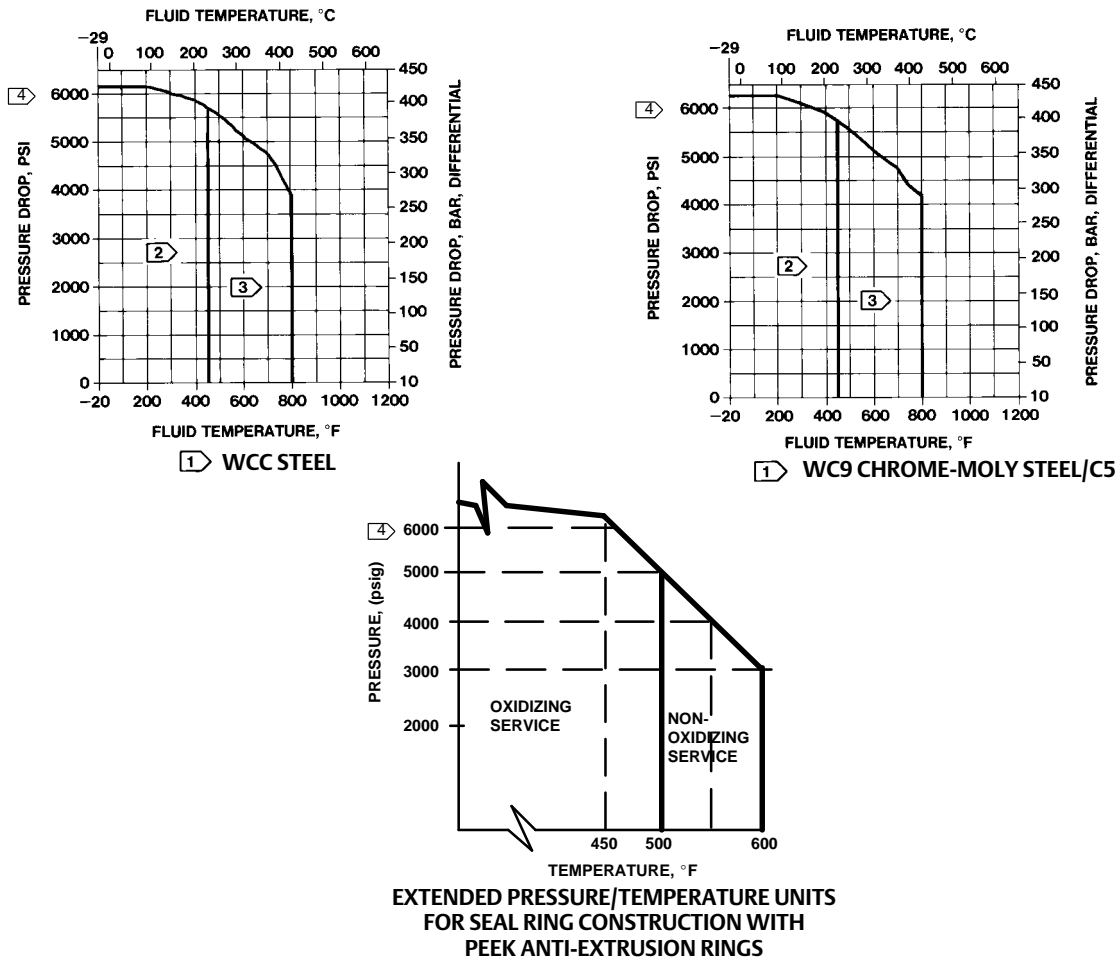

B1605-1

Notes:

- ① Do not exceed the maximum pressure and temperature for the class rating of the body material.
- ② For all constructions.
- ③ For only stem balanced and piston ring constructions.
- ④ Maximum trim pressure drop is 414 bar (6000 psi) for linear trim and 310 bar (4500 psi) for approximate linear trim.

Installation

The CAV4 valve with Cavitrol IV trim must be installed with the actuator mounted vertically above the valve body. Nonvertical positions may cause uneven trim wear and, thus, decrease trim life. Flow through the

valve body must be in the direction indicated by the flow arrow on the valve. For long service life and effective operation, the flowing media should be clean.

Dimensions are shown in figure 7.

Figure 6. Recommended Seat Load Force for All Constructions

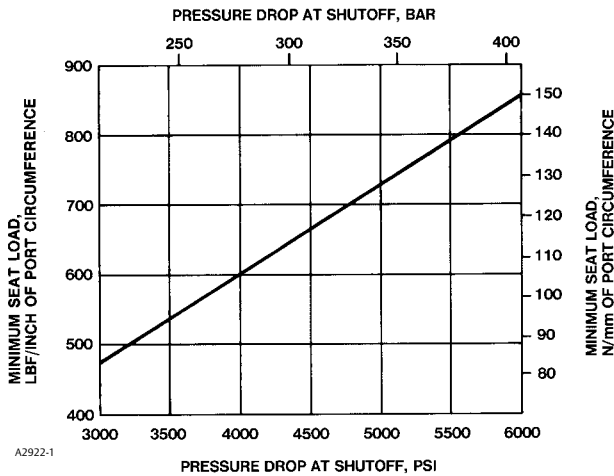

5. Range of flowing inlet pressures
6. Maximum outlet pressure
7. Pressure drops
 - a. Range of flowing pressure drops
 - b. Maximum at shutoff
8. Flow rates
 - a. Minimum controlled flow
 - b. Normal flow
 - c. Maximum flow
9. Required C_v
10. Line size and schedule
11. Angle, globe or offset globe valve body

Ordering Information

When ordering, specify:

Application Information

1. Process liquid—State particle size and type of entrained impurities, if any
2. Specific gravity of liquid
3. Temperature and vapor pressure of liquid
4. Critical pressure

Valve Information

To determine what information is needed for ordering the valve and trim, refer to the specifications. Review the description at the right of each specification or in the referenced tables, figures, and bulletins, and indicate the desired choice wherever there is a selection to be made.

Actuator and Accessory Information

Select the specific actuator and accessories from the appropriate bulletins. Piston or diaphragm actuators may be used. Specify any additional ordering information as required from actuator or accessory bulletins.

Table 5. Dimensions

VALVE SIZE, NPS	END CONNECTION STYLE ⁽¹⁾	A		G		D YOKE BOSS DIAMETER, mm (INCH)							
						90 (3-9/16)		127 (5)		127 (5H)		178 (7)	
		mm	Inch	mm	Inch	mm	Inch	mm	Inch	mm	Inch	mm	Inch
2	BWE	249	9.81	406	16.00	324	12.75	360	14.19	---	---	---	---
	RF	249	9.81	406	16.00	324	12.75	360	14.19	---	---	---	---
	RTJ	251	9.87	408	16.06	324	12.75	360	14.19	---	---	---	---
3	BWE	256	10.06	552	21.75	324	12.75	---	---	---	---	---	---
4	BWE	344	13.56	618	24.31	430	16.94	454	17.88	---	---	454	17.88
	RF	344	13.56	618	24.31	430	16.94	454	17.88	---	---	454	17.88
	RTJ	349	13.75	622	24.50	430	16.94	454	17.88	---	---	454	17.88
6	BWE	457	18.00	1038	40.88	---	---	432	17.00	432	17.00	---	---
	RF	457	18.00	1038	40.88	---	---	432	17.00	432	17.00	---	---
	RTJ	464	18.25	1045	41.13	---	---	432	17.00	432	17.00	---	---

1. BWE—butt weld end; RF—raised flange; RTJ—ring type joint.

Figure 7. Dimensions (also see table 5)

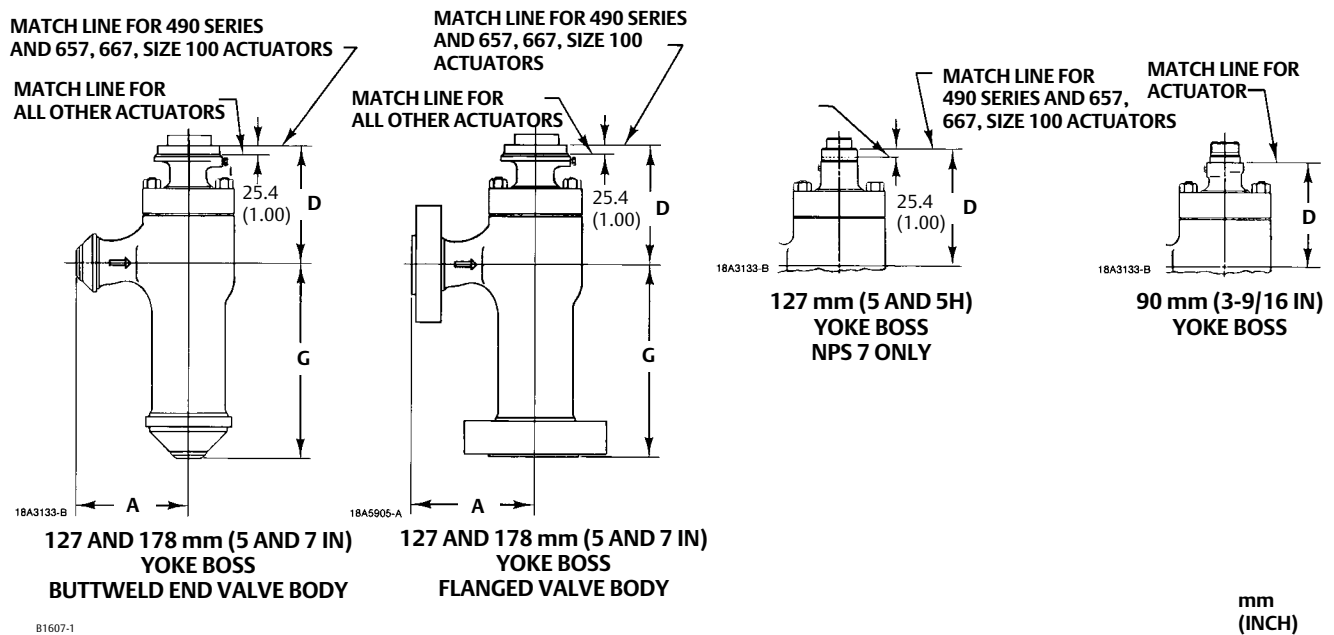

Note:
For dimensions of valves with PN (or other) end connections, consult your [Emerson sales office](#) or Local Business Partner.

Product Bulletin

51.2:CAV4
January 2018

CAV4 Valve
D101497X012

Neither Emerson, Emerson Automation Solutions, nor any of their affiliated entities assumes responsibility for the selection, use or maintenance of any product. Responsibility for proper selection, use, and maintenance of any product remains solely with the purchaser and end user.

Fisher, Cavitrol, and ENVIRO-SEAL are marks owned by one of the companies in the Emerson Automation Solutions business unit of Emerson Electric Co. Emerson Automation Solutions, Emerson, and the Emerson logo are trademarks and service marks of Emerson Electric Co. All other marks are the property of their respective owners.

The contents of this publication are presented for informational purposes only, and while every effort has been made to ensure their accuracy, they are not to be construed as warranties or guarantees, express or implied, regarding the products or services described herein or their use or applicability. All sales are governed by our terms and conditions, which are available upon request. We reserve the right to modify or improve the designs or specifications of such products at any time without notice.

Emerson Automation Solutions
Marshalltown, Iowa 50158 USA
Sorocaba, 18087 Brazil
Cernay, 68700 France
Dubai, United Arab Emirates
Singapore 128461 Singapore

www.Fisher.com

