

# Rosemount™ 485 Annubar™ Threaded Flo-Tap Assembly

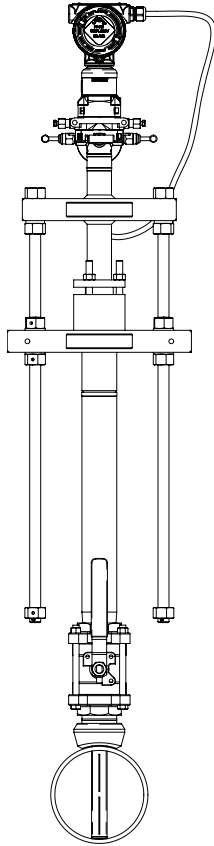

**NOTICE**

This guide provides basic guidelines for Rosemount 485 Annubar. It does not provide instructions for configuration, diagnostics, maintenance, service, troubleshooting, Explosion-proof, Flameproof, or Intrinsically Safe (I.S.) installations. Refer to Rosemount 485 Annubar [Reference Manual](#) for more instruction. This manual is also available electronically on [EmersonProcess.com/Rosemount](http://EmersonProcess.com/Rosemount).

If the Rosemount Annubar was ordered assembled to a Rosemount Pressure Transmitter, see the following Quick Start Guides for information on configuration and hazardous locations certifications:

- Rosemount 3051S Series Pressure Transmitter and Rosemount 3051SF Series Flowmeter [Quick Start Guide](#).
- Rosemount 3051S MultiVariable Transmitter and Rosemount 3051SF Series Flowmeter MultiVariable Transmitter [Quick Start Guide](#).
- Rosemount 3051 Pressure Transmitter and Rosemount 3051CF Series Flowmeter Transmitter [Quick Start Guide](#).
- Rosemount 2051 Pressure Transmitter and Rosemount 2051CF Series Flowmeter Transmitter [Quick Start Guide](#).

**⚠ WARNING**

Process leaks may cause harm or result in death. To avoid process leaks, only use gaskets designed to seal with the corresponding flange and o-rings to seal process connections. Flowing medium may cause the Rosemount 485 Annubar Assembly to become hot and could result in burns.

**Contents**

Location and orientation . . . . .	4	Insert the Rosemount Annubar Sensor . . . . .	11
Weld mounting hardware . . . . .	8	Mount the transmitter . . . . .	12
Install isolation valve . . . . .	9	Retracting the Rosemount Annubar Assembly . . . . .	18
Mount drilling machine and drill hole . . . . .	9	Product certifications . . . . .	19
Mount the Rosemount Annubar Assembly . . . . .	10		

**Figure 1. Rosemount 485 Annubar Threaded Flo-Tap Assembly Exploded View**

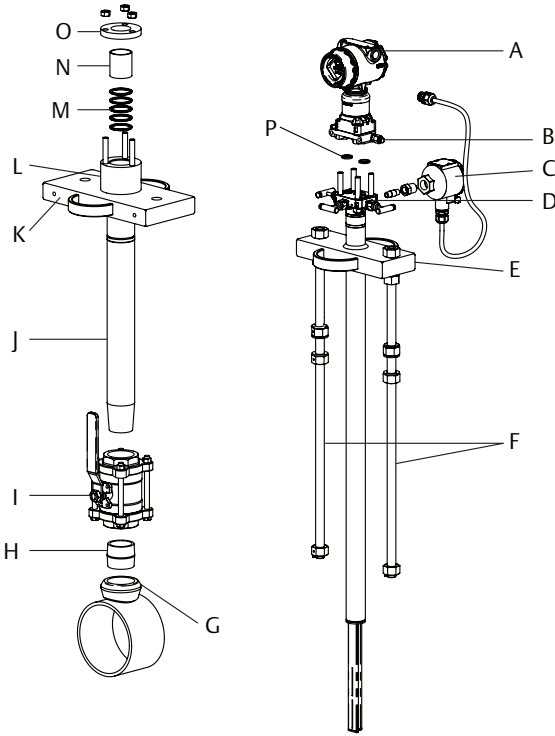

- |  |                      |
|--|----------------------|
| A. Transmitter                                     | I. Isolation valve   |
| B. Coplanar flange with drain vents                | J. Cage nipple       |
| C. Temperature sensor connection housing           | K. Support plate     |
| D. Direct mount transmitter connection with valves | L. Packing gland     |
| E. Head plate                                      | M. Packing           |
| F. Drive rods                                      | N. Follower          |
| G. Threaded pipe fitting                           | O. Compression plate |
| H. Guide nipple                                    | P. 2× O-rings        |



**Note**

Use an appropriate pipe sealing compound rated for the service temperature on all threaded connections.

# 1.0 Location and orientation

Correct orientation and straight run requirements must be met for accurate and repeatable flow measurements. Refer to [Table 1](#) for minimum pipe diameter distances from upstream disturbances.

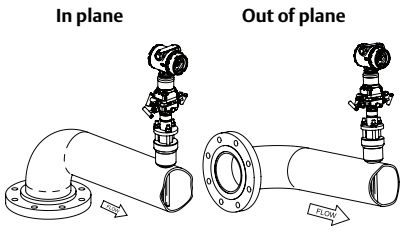
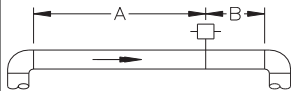
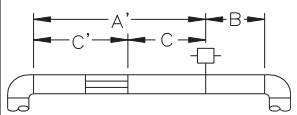
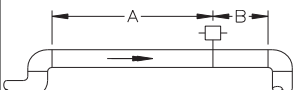
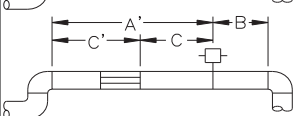
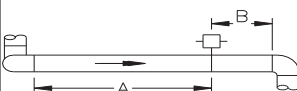
**Table 1. Straight Run Requirements**

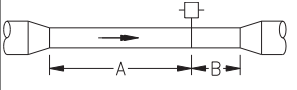
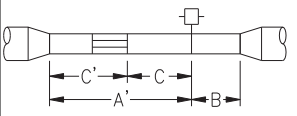
		Upstream pipe diameters					Downstream pipe diameters
		Without straightening vanes		With straightening vanes			
		In plane A	Out of plane A	A'	C	C'	
1		8	10	N/A	N/A	N/A	4
		N/A	N/A	8	4	4	4
2		11	16	N/A	N/A	N/A	4
		N/A	N/A	8	4	4	4
3		23	28	N/A	N/A	N/A	4
		N/A	N/A	8	4	4	4
4		12	12	N/A	N/A	N/A	4
		N/A	N/A	8	4	4	4

5		18	18	N/A	N/A	N/A	4
		N/A	N/A	8	4	4	4
6		30	30	N/A	N/A	N/A	4
		N/A	N/A	8	4	4	4

**Note**

- Consult the factory for instructions regarding use in square or rectangular ducts.
- “In plane A” means the sensor is in the same plane as the elbow. “Out of plane A” means the sensor is perpendicular to the plane of the elbow.
- If proper lengths of straight run are not available, position the mounting such that 80% of the run is upstream and 20% is downstream.
- Use straightening vanes to reduce the required straight run length.
- Row 6 in Table 1 applies to gate, globe, plug, and other throttling valves that are partially opened, as well as control valves.

### 1.1 Misalignment

Rosemount 485 installation allows for a maximum misalignment of 3°.

**Figure 2. Misalignment**

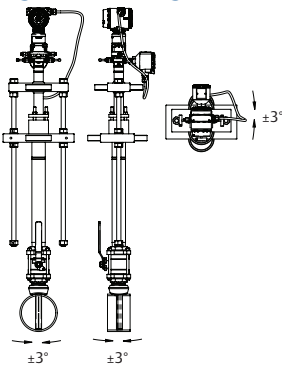

## 1.2 Horizontal orientation

For proper venting and draining, the sensor should be located in the upper half of the pipe for air and gas applications. For liquid and steam applications, the sensor should be located in the bottom half of the pipe. The maximum temperature for a direct mounted transmitter is 500 °F (260 °C).

**Figure 3. Gas**

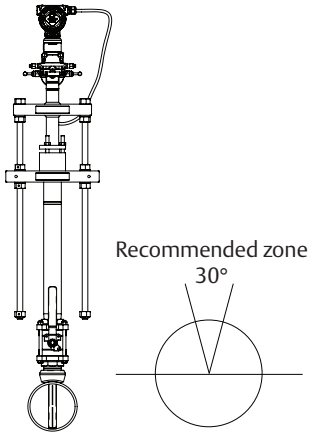

**Figure 4. Liquid and Steam**

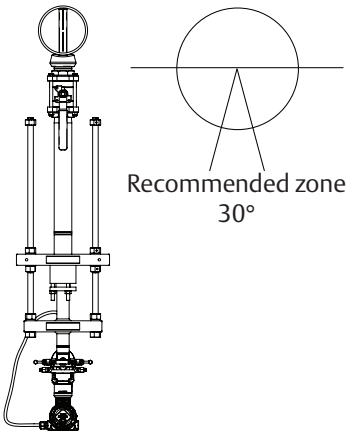

**Note**

Top mounting for steam applications is an appropriate mounting option in many cases. Consult Rosemount Customer Central instructions regarding steam on top mounting.

### 1.3 Vertical orientation

The sensor can be installed in any position around the circumference of the pipe provided the vents are positioned properly for bleeding or venting. Optimal results for liquid or steam are obtained when flow is up. For steam applications, a 90° spacer will be added to provide water legs to ensure the transmitter stays within temperature limits. The maximum temperature for a direct mounted transmitter is 500 °F (260 °C).

**Figure 5. Steam**

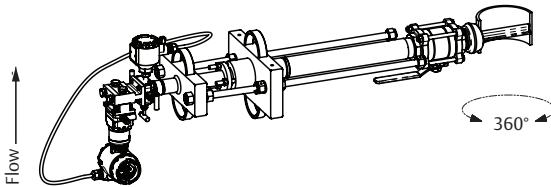

**Figure 6. Liquid**

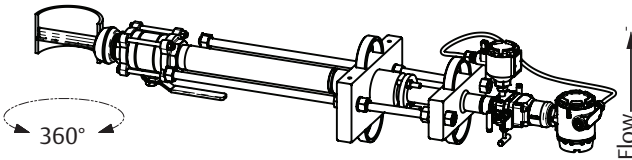

**Figure 7. Gas**

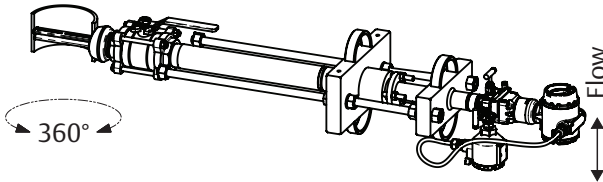

## 2.0 Weld mounting hardware

### Note

Rosemount-supplied mounting has an integral alignment built into the mounting hardware that assists in the correct drilling of the mounting hole. It also assists in the alignment of the sensor to the mounting hole for insertion.

1. At the pre-determined position, place the threaded weld coupling on the pipe, gap  $\frac{1}{16}$ -in. (1,6 mm), and place four  $\frac{1}{4}$ -in. (6 mm) tack welds at 90° increments.
2. Check alignment of the mounting both parallel and perpendicular to the axis of flow (see Figure 8). If alignment of the mounting is within tolerances, finish weld per local codes. If outside of specified tolerance, make adjustments prior to making the finish weld.

**Figure 8. Alignment**

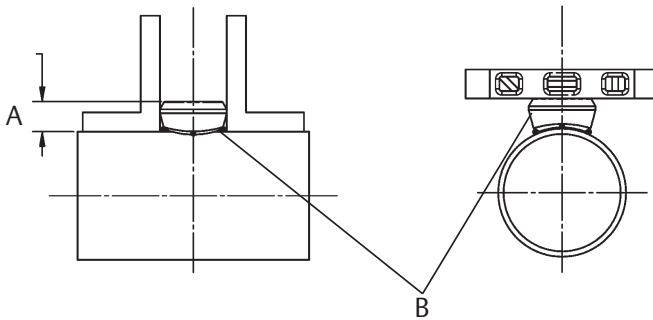

A. Lower Mounting Height (LMH)<sup>(1)</sup>

B. Tack welds

1. LMH values are as follows:  
 Sensor size 1 — 1.38-in.(35 mm)  
 Sensor size 2 — 1.56-in.(40 mm)  
 Sensor size 3 — 2.06-in.(52 mm)

3. To avoid serious burns, allow the mounting hardware to cool before continuing.



### 3.0 Install isolation valve

1. Thread the guide nipple into the mounting.
2. Thread the isolation valve onto the guide nipple. Ensure the valve stem is positioned so that when the Flo-Tap is installed, the insertion rods will straddle the pipe and the valve handle will be centered between the rods (see [Figure 9](#)).

**Note**

Interference will occur if valve is located in line with the rods.

**Figure 9. Isolation Valve Orientation**

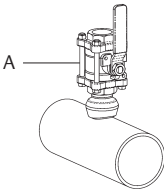

A. Isolation valve

### 4.0 Mount drilling machine and drill hole

Drilling machine is not provided with assembly.

1. Determine the sensor size based on the probe width (see [Table 2](#)).

**Table 2. Sensor Size/Hole Diameter Chart**

Sensor size	Sensor width	Hole diameter	
1	0.590-in. (14,99 mm)	<sup>3</sup> / <sub>4</sub> -in. (19 mm)	+ <sup>1</sup> / <sub>32</sub> -in. (0,8 mm) – 0.00
2	1.060-in. (26,92 mm)	1 <sup>5</sup> / <sub>16</sub> -in. (34 mm)	+ <sup>1</sup> / <sub>16</sub> -in. (1,6 mm) – 0.00
3	1.935-in. (49,15 mm)	2 <sup>1</sup> / <sub>2</sub> -in. (64 mm)	+ <sup>1</sup> / <sub>16</sub> -in. (1,6 mm) – 0.00

2. Mount the drilling machine to the isolation valve.

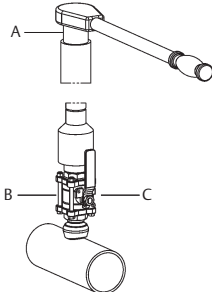

- A. Isolation valve is fully open when inserting drill
- B. Pressure drilling machine
- C. Isolation valve is fully closed after withdrawing drill

3. Open the valve fully.
4. Drill the hole into the pipe wall in accordance with the instructions provided by the drilling machine manufacturer (use [Table 2](#) to select the proper drill bit for the sensor being used).
5. Retract the drill fully beyond the valve.

## 5.0 Remove drilling machine

1. Verify the drill has been retracted past the valve.
2. Close the isolation valve to isolate the process.
3. Bleed drilling machine pressure and remove.
4. Check isolation valve and mounting for leakage.

## 6.0 Mount the Rosemount Annubar Assembly

1. Install the complete Flo-Tap assembly (fully retracted) onto the isolation valve by threading the close nipple into the valve using the proper thread sealant compound.
2. Rotate the Flo-Tap assembly until the flow arrow on the head aligns with the direction of flow.
3. Ensure the vent valves are closed before proceeding.
4. Quickly open and close the isolation valve to pressurize the sensor and identify any leak points in the installation. Use extreme caution if the flowing medium is steam or caustic.
5. Check the entire installation for leakage. Tighten as required to stop any connection from leaking.
6. Repeat steps 4 and 5 until there is no leakage.
  - a. If Flo-Tap comes equipped with the gear drive option, place the Polyvinyl chloride (PVC) protector rod assembly over the drive rods and attach to gear drive with supplied hardware.

---

### Note

Rosemount 485 Annubar Flowmeter have the potential to carry a large amount of weight at a great distance from the piping, necessitating external support. The support plate has threaded holes to assist in supporting the Rosemount 485.

---

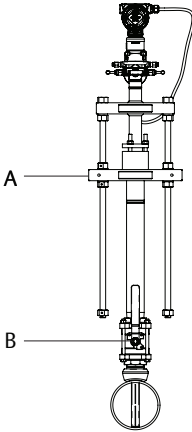
**Figure 10. Install Flo-Tap Assembly**

- A. Support plate  
B. Isolation valve

## 7.0 Insert the Rosemount Annubar Sensor

### Standard drive (M)

1. Open the isolation valve fully.
2. Rotate the drive nuts clockwise (as viewed from the top). The nuts must be tightened alternately, about two turns at a time, to prevent binding caused by unequal loading.
3. Continue this procedure until the tip of the sensor firmly contacts the opposite side of the pipe.
  - a. The orange stripes are visual indication of when the sensor is approaching the opposite side wall.
  - b. As the orange stripe approaches the support plate, place a finger above the packing gland while cranking. When movement stops, the sensor is in contact with the opposite side wall.
  - c. Turn the handle an additional  $1/4$ - to  $1/2$ -in. to secure the sensor.

## Gear drive (G)

1. Open the isolation valve fully.
2. Rotate the crank clockwise. If a power drill with an adapter is used, do not exceed 200 rpm.
  - a. Continue rotating the crank until the sensor firmly contacts the opposite side of the pipe. The orange stripes are visual indication of when the sensor is approaching the opposite side wall.
  - b. As the orange stripes approach the support plate, remove the power drill and continue cranking manually. Place a finger above the packing gland while cranking. When movement stops, the sensor is in contact with the opposite side wall.
  - c. Turn the handle an additional  $1/4$ - to  $1/2$ -in. to secure the sensor.
3. Secure the drive by inserting the drive lock pin as shown in [Figure 11](#).

---

### Note

Do not place finger above packing gland for high temperature applications.

---

**Figure 11. Insert the Sensor**

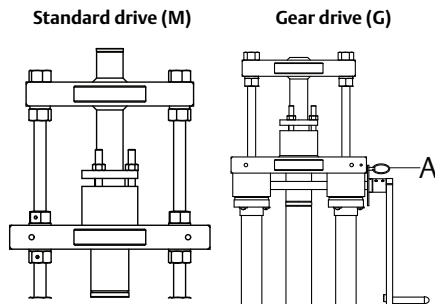

A. Drive lock pin

---

## 8.0 Mount the transmitter

### 8.1 Transmitter mounting, direct mount head with valves

It is not necessary to retract the Rosemount Annubar when direct mounting a transmitter with valves.

1. Place PTFE O-rings into grooves on the Rosemount Annubar head.
2. Align the high side of the transmitter to the high side of the sensor (“Hi” is stamped on the side of the head) and install.
3. Tighten the nuts in a cross pattern to 384 in-lb (43 N-m).

## 8.2 Transmitter mounting with remote mount head

Temperatures in excess of 250 °F (121 °C) at the sensor module diaphragms will damage the transmitter. Remote mounted transmitters are connected to the sensor by means of impulse piping, which allows service flow temperatures to decrease to a point where the transmitter is no longer vulnerable.

Different impulse piping arrangements are used depending on the process fluid and must be rated for continuous operation at the pipeline design pressure and temperature. A minimum of 1/2-in. (12 mm) outer diameter stainless steel tubing with a wall thickness of at least 0.035-in. (1 mm) is recommended. Threaded pipe fittings are not recommended because they create voids where air can become entrapped and create leakage points.

The following restrictions and recommendations apply to impulse piping location:

1. Impulse piping that runs horizontally must slope at least one inch per foot (83 mm/m).
  - Slope downward (toward the transmitter) for liquid and steam applications.
  - Slope upward (toward the transmitter) for gas applications.
2. Outdoor installations for liquid, saturated gas, or steam may require insulation and heat tracing to prevent freezing.
3. An instrument manifold is recommended for all installations. Manifolds allow an operator to equalize the pressures prior to zeroing and isolates the process fluid from the transmitter.

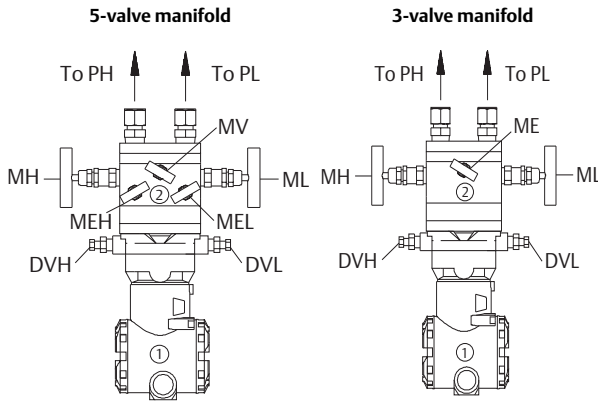
**Figure 12. Valve Identification for 5-Valve and 3-Valve Manifolds****Table 3. Description of Impulse Valves and Components**

Name	Description	Purpose
Components		
1	Transmitters	Reads Differential Pressure
2	Manifold	Isolates and equalizes transmitter
Manifold and impulse valves		
PH	Primary sensor <sup>(1)</sup>	High and low side pressure process connections.
PL	Primary sensor <sup>(2)</sup>	
DVH	Drain/vent valve <sup>(1)</sup>	Drains (for gas service) or vents (for liquid or steam service) the DP transmitter chambers
DVL	Drain/vent valve <sup>(2)</sup>	
MH	Manifold <sup>(1)</sup>	Isolates high side or low side pressure from the process
ML	Manifold <sup>(2)</sup>	
MEH	Manifold equalizer <sup>(1)</sup>	Allows high and low pressure side access to the vent valve, or for isolating the process fluid
MEL	Manifold equalizer <sup>(2)</sup>	
ME	Manifold equalizer	Allows high and low side pressure to equalize
MV	Manifold vent valve	Vents process fluid

1. High pressure

2. Low pressure

## 8.3 Recommended installations

### Gas service

Secure the transmitter above the sensor to prevent condensible liquids from collecting in the impulse piping and the DP cell.

---

**Figure 13. Horizontal Gas**

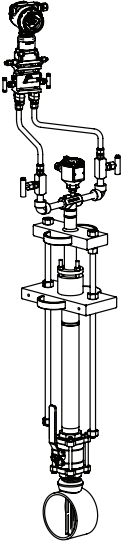

---

**Figure 14. Vertical Gas**

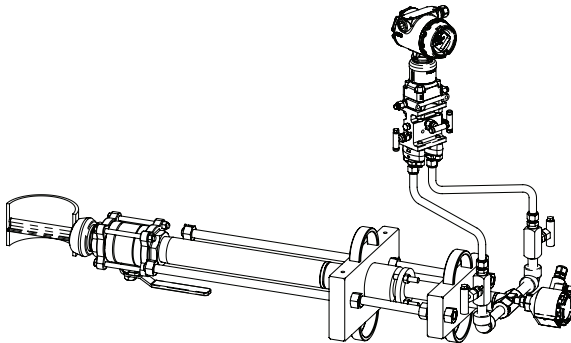

## Steam and liquid service

Secure the transmitter below the sensor to ensure that air will not be introduced into the impulse piping or the transmitter.

**Figure 15. Horizontal Steam and Liquid**

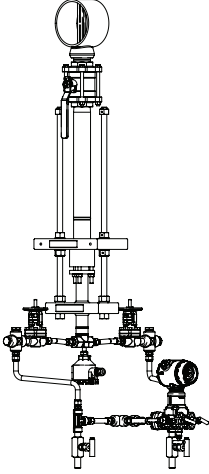

**Figure 16. Vertical Steam and Liquid**

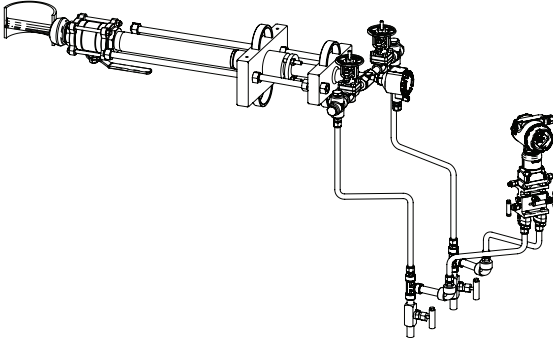



---

## Top mounting for steam service

Top mounting for steam applications is an appropriate mounting option in many cases. Consult Rosemount Customer Central instructions regarding steam on top mounting. For remote mount installations the impulse piping should slope up slightly from the instrument connections on the Rosemount Annubar to the cross fittings allowing condensate to drain back into the pipe. From the cross fittings, the impulse piping should be routed downward to the transmitter and the drain legs. The transmitter should be located below the instrument connections of the Rosemount Annubar. Depending on the environmental conditions, it may be necessary to insulate the mounting hardware.

---

**Figure 17. Horizontal Top Mounting for Steam**

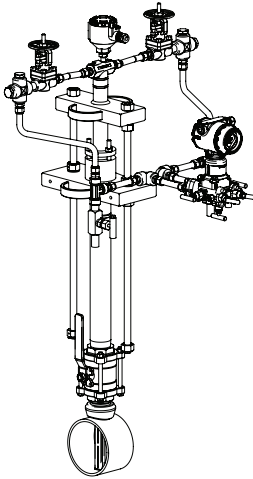

---

### Note

Top mounting for steam applications is an appropriate mounting option in many cases. Consult Rosemount Customer Central instructions regarding steam on top mounting.

---

## 9.0 Retracting the Rosemount Annubar Assembly

### 9.1 Standard drive (M)

1. Rotate the drive nuts counter-clockwise (as viewed from the top). The nuts must be loosened alternately, about two turns at a time, to prevent binding caused by unequal loading.
2. Continue this procedure until the rod end nuts are against the packing body mechanism.

### 9.2 Gear drive (G)

1. Remove the drive lock pin.
2. Rotate the crank counter-clockwise. If a power drill with an adapter is used, do not exceed 200 rpm.
3. Retract until the rod end nuts are against the gear box mechanism.

## 10.0 Product certifications

### 10.1 Approved Manufacturing Locations

Rosemount Inc. – Shakopee, Minnesota USA

Rosemount DP Flow Design and Operations – Boulder, Colorado USA

Emerson Process Management GmbH & Co. OHG – Wessling, Germany

Emerson Process Management Asia Pacific Private Limited – Singapore

Emerson Beijing Instrument Co., Ltd – Beijing, China

### 10.2 European Directive Information

The EC declaration of conformity for all applicable European directives for this product can be found on the Rosemount website at [EmersonProcess.com/Rosemount](http://EmersonProcess.com/Rosemount). A hard copy may be obtained by contacting our local sales office.

#### **European Pressure Equipment Directive (PED) (97/23/EC)**

Rosemount 485 Annubar — Refer to EC declaration of conformity for conformity assessment



Pressure Transmitter — See appropriate Pressure Transmitter QSG

### 10.3 Hazardous Locations Certifications

For information regarding the transmitter product certification, see the appropriate transmitter QSG:

- Rosemount 3051S Series Pressure Transmitter and Rosemount 3051SF Series Flowmeter [Quick Start Guide](#).
- Rosemount 3051S MultiVariable Transmitter and Rosemount 3051SF Series Flowmeter MultiVariable Transmitter [Quick Start Guide](#).
- Rosemount 3051 Pressure Transmitter and Rosemount 3051CF Series Flowmeter Transmitter [Quick Start Guide](#).
- Rosemount 2051 Pressure Transmitter and Rosemount 2051CF Series Flowmeter Transmitter [Quick Start Guide](#).

Figure 18. Rosemount Primary Element Declaration of Conformity

	<h1>EU Declaration of Conformity</h1>	
<p>No: DSI 1000 Rev. L</p>		
<p>We,</p>		
<p><b>Rosemount, Inc.</b>  <b>8200 Market Boulevard</b>  <b>Chanhasen, MN 55317-9685</b>  <b>USA</b></p>		
<p>declare under our sole responsibility that the products,</p>		
<p><b>Rosemount Primary Elements: 405x, 485, 585, 1195, 1495, 1595</b>  <b>Rosemount DP Flowmeters: 2051CFx, 3051CFx, 3051SFx</b></p>		
<p>manufactured by,</p>		
<p><b>Rosemount / Dieterich Standard, Inc.</b>  <b>5601 North 71<sup>st</sup> Street</b>  <b>Boulder, CO 80301</b>  <b>USA</b></p>		
<p>to which this declaration relates, is in conformity with the provisions of the European Union Directives as shown in the attached schedule.</p>		
<p>Assumption of conformity is based on the application of the harmonized standards and, when applicable or required, a European Union notified body certification, as shown in the attached schedule.</p>		
 <small>(signature)</small>	<p>Vice President of Global Quality  <small>(function)</small></p>	
<p>Kelly Klein  <small>(name)</small></p>	<p>19 Apr 2016  <small>(date of issue)</small></p>	
<p>Page 1 of 3</p>		
<p>DSI 1000.docx</p>		



# EU Declaration of Conformity



No: DSI 1000 Rev. L

**PED Directive (97/23/EC) This directive is valid until 18 July 2016**  
**PED Directive (2014/68/EU) This directive is valid from 19 July 2016**

Summary of Classifications		
Model/Range	PED Category	
	Group 1 Fluid	Group 2 Fluid
Rosemount 585 - 150#-900# All Lines	SEP	SEP
Rosemount 585 - 1500# & 2500# All Lines	III	SEP
Rosemount 405C, 405A, x051xFC	SEP	SEP
Rosemount 1195, x051xFP with 150#, 1-1/2" Flange	I	SEP
Rosemount 1195, x051xFP with 300# or 600#, 1" or 1-1/2" Flange	II	I
Rosemount 1195, x051xFP with 1" or 1-1/2" Threaded & Welded Connection	II	I
Rosemount 485/x051xFA: 1500# & 2500# All Line Sizes, Flanged	III	SEP
Rosemount 485/x051xFA: Sensor Size 2, 150#, 6" to 24" Line Sizes, FloTap	I	SEP
Rosemount 485/x051xFA: Sensor Size 2, 300#, 6" to 24" Line Sizes, FloTap	II	I
Rosemount 485/x051xFA: Sensor Size 2, 600#, 6" to 16" Line Sizes, FloTap	II	I
Rosemount 485/x051xFA: Sensor Size 2, 600#, 18" to 24" Line Sizes, FloTap	III	II
Rosemount 485/x051xFA: Sensor Size 3, 150#, 12" to 44" Line Sizes, FloTap	II	I
Rosemount 485/x051xFA: Sensor Size 3, 150#, 46" to 72" Line Sizes, FloTap	III	II
Rosemount 485/x051xFA: Sensor Size 3, 300#, 12" to 72" Line Sizes, FloTap	III	II
Rosemount 485/x051xFA: Sensor Size 3, 600#, 12" to 36" Line Sizes, FloTap	III	II
Rosemount 485/x051xFA: Sensor Size 3, 600#, 48" to 72" Line Sizes, FloTap	IV*	III
All other Rosemount Primary Elements and DP Flowmeters	SEP	SEP

**Certificate of Assessment – CE-0041-H-RMT-001-13-USA**

*IV\* Category IV Flo Tap requires a B1 Certificate for design examination and H1 Certificate for special surveillance*



# EU Declaration of Conformity



No: DSI 1000 Rev. L

**Pressure Equipment Directive Notified Body:**

**Bureau Veritas UK Limited** [Notified Body Number: 0041]  
Parklands, Wilmslow Road, Didsbury  
Manchester M20 2RE  
United Kingdom

**表格 1B: 含有 China RoHS 管控物质超过最大浓度限值的部件型号列表 Rosemount 485**  
**Table 1B: List of Rosemount 485 Parts with China RoHS Concentration above MCVs**

部件名称 Part Name	有害物质 / Hazardous Substances					
	铅 Lead (Pb)	汞 Mercury (Hg)	镉 Cadmium (Cd)	六价铬 Hexavalent Chromium (Cr +6)	多溴联苯 Polybrominated biphenyls (PBB)	多溴联苯醚 Polybrominated diphenyl ethers 多溴联苯醚 (PBDE)
铝制温度传感器外壳组件 Aluminum RTD Housing Assembly	O	O	O	X	O	O

本表格系依据 SJ/T11364 的规定而制作。

This table is proposed in accordance with the provision of SJ/T11364

O: 意为该部件的所有均质材料中该有害物质的含量均低于 GB/T 26572 所规定的限量要求。

O: Indicate that said hazardous substance in all of the homogeneous materials for this part is below the limit requirement of GB/T 26572.

X: 意为在该部件所使用的的所有均质材料里，至少有一类均质材料中该有害物质的含量高于 GB/T 26572 所规定的限量要求。

X: Indicate that said hazardous substance contained in at least one of the homogeneous materials used for this part is above the limit requirement of GB/T 26572.

上述申明仅适用于选择铝制外壳组件的产品。其他所有差压流量一次元件的组件所含有的 China RoHS 管控物质浓度均低于 GB/T 26572 所规定的限量要求。关于差压流量计变送器组件的管控物质浓度的申明，请参看变送器的快速安装指南。

The disclosure above applies to units supplied with aluminum connection heads. No other components supplied with DP Flow primary elements contain any restricted substances. Please consult the transmitter Quick Start Guide (QIG) for disclosure information on transmitter components.



### Global Headquarters

#### Emerson Process Management

6021 Innovation Blvd.  
Shakopee, MN 55379, USA  
+1 800 999 9307 or +1 952 906 8888  
+1 952 949 7001  
RFQ.RMD-RCC@EmersonProcess.com

### North America Regional Office

#### Emerson Process Management

8200 Market Blvd.  
Chanhassen, MN 55317, USA  
+1 800 999 9307 or +1 952 906 8888  
+1 952 949 7001  
RMT-NA.RCCRFQ@Emerson.com

### Latin America Regional Office

#### Emerson Process Management

1300 Concord Terrace, Suite 400  
Sunrise, FL 33323, USA  
+1 954 846 5030  
+1 954 846 5121  
RFQ.RMD-RCC@EmersonProcess.com

### Europe Regional Office

#### Emerson Process Management Europe GmbH

Neuhofstrasse 19a P.O. Box 1046  
CH 6340 Baar  
Switzerland  
+41 (0) 41 768 6111  
+41 (0) 41 768 6300  
RFQ.RMD-RCC@EmersonProcess.com

### Asia Pacific Regional Office

#### Emerson Process Management Asia Pacific Pte Ltd

1 Pandan Crescent  
Singapore 128461  
+65 6777 8211  
+65 6777 0947  
Enquiries@AP.EmersonProcess.com

### Middle East and Africa Regional Office

#### Emerson Process Management

Emerson FZE P.O. Box 17033,  
Jebel Ali Free Zone - South 2  
Dubai, United Arab Emirates  
+971 4 8118100  
+971 4 8865465  
RFQ.RMTMEA@Emerson.com



Linkedin.com/company/Emerson-Process-Management



Twitter.com/Rosemount\_News



Facebook.com/Rosemount



Youtube.com/user/RosemountMeasurement



Google.com/+RosemountMeasurement

Standard Terms and Conditions of Sale can be found at

[www.Emerson.com/en-us/pages/Terms-of-Use.aspx](http://www.Emerson.com/en-us/pages/Terms-of-Use.aspx)

The Emerson logo is a trademark and service mark of Emerson Electric Co.

Annubar, Rosemount and Rosemount logotype are trademarks of Emerson Process Management.

All other marks are the property of their respective owners.

© 2016 Emerson Process Management. All rights reserved.