









Rosemount™ 8800D Approval Document



Rosemount 8800 Vortex Flow Meter Global Certificate Summary

Order Code	8800 Vortex Flow Meter Ratings	Region	Agency	Certification Number
-	Ordinary Location *	USA, Canada, EU, CU**	CSA or EAC	70054084X (CSA)
E5, E6 K6, KB	Explosionproof-Intrinsically Safe (Class I, Division 1) Flameproof-Intrinsically Safe (Class I, Zone 1) Dust Ignitionproof (Class II and III, Division 1) Non-Incendive (Class I, Division 2)	USA, Canada	CSA	70054084X
I5, I6, IF K6, KB	Intrinsically Safe (Class I, II, III, Division 1) Entity; FISCO Intrinsically Safe (Class I, Zone 0) Non-Incendive (Class I, Division 2) NIFW; FNICO	USA, Canada	CSA	70054084X
E7, K7	Flameproof Enclosure and/or Intrinsically Safe	Global	DEKRA	IECEX KEM 05.0017X
I7, IG, K7	Intrinsic Safety	Global	Baseefa	IECEX BAS 05.0028X
N7, K7	Non-Sparking (Type n)	Global	Baseefa	IECEX BAS 05.0029X
NF, K7	Protection by Enclosure (Ex tb) (Dust)	Global	Baseefa	IECEX BAS 17.0019X
E1, K1	Flameproof Enclosure and/or Intrinsically Safe	EU	DEKRA	KEMA99ATEX3852 X
I1, IA, K1	Intrinsic Safety	EU	Baseefa	Baseefa05ATEX0084X
N1, K1	Non-Sparking (Type n)	EU	Baseefa	Baseefa05ATEX0085X
ND, K1	Protection by Enclosure (Ex tb) (Dust)	EU	Baseefa	Baseefa17ATEX0020X
E2, K2	Flameproof Enclosure and/or Intrinsically Safe	Brazil	TUV-INMETRO	TUV 16.1959 X
I2, IB, K2	Intrinsic Safety	Brazil	TUV-INMETRO	TUV 16.1958 X
EP	Flameproof (Integral Mount only)	Korea	KTL	16-KA4BO-0234X
--	Intrinsic Safety	Korea	KTL	Planned***
E3, K3	Flameproof Enclosure and/or Intrinsically Safe	China	NEPSI	GYJ17.1404X
I3, IH, K3	Intrinsic Safety	China	NEPSI	GYJ17.1196X
N3, K3	Non-Sparking (Type n)	China	NEPSI	GYJ17.1197X
--, K3	Protection by Enclosure (Ex tD) (Dust)	China	NEPSI	GYJ17.1181X
E4	Flameproof, Intrinsic Safety	Japan	CML	CML 17JPN1145X
--	Flameproof	India	CCOE / PESO	None
--	Intrinsic Safety	India	CCOE / PESO	None
E8, I8, G8, N8, K8	Flameproof, Intrinsic Safety, Type n,	Russia**	HAHIO ЦСБЭ	TC RU C- US.ГБ05.B.01272
SBS	Marine Certification per ABS Rules	Marine	ABS	Confirmation of Product Type Approval: 18-HS1745164-PDA-DUP
SBV	Marine Certification per Bureau Veritas Rules	Marine	BUREAU VERITAS	26326/B0 BV
SDN	Marine Certification per DNV GL Rules	Marine	DNV GL	TAA00000KA
SLL	Marine Certification per Lloyd's Register Rules	Marine	LLOYD'S	14/60023
<p>* Complies with only the local country product safety, electromagnetic, pressure and other applicable regulations. Cannot be used in a classified or zoned hazardous location environment. No ordering code required.</p> <p>** Customs Union (Russia, Belarus and Kazakhstan)</p> <p>*** Planned submittal or in process with Agency.</p> <p>**** Where "X" will vary depending upon the factory location and specific certification.</p>				

Approval Markings and Logos

Symbol	Marking or Symbol Name	Region	Meaning of Marking or Symbol
	CE	European Union	Compliance with all applicable European Union Directives.
	ATEX	European Union	Compliance with Equipment and Protective systems intended for use in Potentially Explosive Atmospheres directive (ATEX) (2014/34/EU)
	C-tick	Australia	Compliance with Australian applicable electromagnetic compatibility standards
	CSA	US = United States C = Canada	Indicates that the product was tested and has met the applicable certification requirements for the noted countries.
	Eurasian Conformity (EAC)	Eurasian Customs Union (Russia, Belarus and Kazakhstan)	Compliance with all the applicable technical regulations of the EAC Customs Union
	EAC Hazardous Location	Eurasian Customs Union (Russia, Belarus and Kazakhstan)	Compliance with Technical regulation, (TR CU 012/2011) – The safety of equipment for use in explosive environments.
	INMETRO	Brazil	Compliance with all the applicable technical regulations of Brazil.
	NEPSI	China	Compliance with all the applicable technical regulations of China.
	KTL	Korea	Compliance with all the applicable technical regulations of Korea.

Product designated for Ordinary Location may be marked with CE, C-tick, CSA and/or EAC logos.

US and Canadian Certifications

CSA Certificate: 70054084 X

Order Code E5 or E6

Class / Divisions:

Explosion-Proof for Class I, Division 1, Groups B, C, and D. Temperature Class T6; $T_a = -50\text{ °C} \leq T_a \leq 70\text{ °C}$

Dust ignition-proof for Class II, III Division 1, Groups E, F, G. Temperature Class T6; $T_a = -50\text{ °C} \leq T_a \leq 70\text{ °C}$

Factory Sealed; Single Seal up to MWP 3600 PSI; Enclosure Type 4X; Install per drawing 08800-0112

Class / Zones: IP66

Ex db [ia] IIC T6...T1 Gb $(-50\text{ °C} \leq T_a \leq 70\text{ °C})$

Class I, Zone 1, AEx db [ia] IIC T6...T1 Gb $(-50\text{ °C} \leq T_a \leq 70\text{ °C})$

Thermal data:

Ambient temperature (°C)	Process temperature (°C)	T-Class sensor
-50 to +70	-200 to +75	T6
-50 to +70	-200 to +95	T5
-50 to +70	-200 to +130	T4
-50 to +70	-200 to +195	T3
-50 to +70	-200 to +290	T2
-50 to +70	-200 to +427	T1

Order Code I5 or I6

Class / Divisions:

Intrinsically safe for use in Class I, II, III Division 1, Groups A, B, C, D, E, F, G;

Non-incendive for Class I, Division 2, Groups A, B, C and D

Temperature Code T4 $(-50\text{ °C} \leq T_a \leq 70\text{ °C})$ 4-20 mA HART

Temperature Code T4 $(-50\text{ °C} \leq T_a \leq 60\text{ °C})$ Fieldbus, FISCO

Single Seal up to MWP 3600 PSI; Enclosure Type 4X; Install per drawing 08800-0112

Class / Zones: IP66

Class I, Zone 0, AEx ia IIC T4 Ga

Temperature Code T4 $(-50\text{ °C} \leq T_a \leq 70\text{ °C})$ 4-20 mA HART

Temperature Code T4 $(-50\text{ °C} \leq T_a \leq 60\text{ °C})$ Fieldbus, FISCO

Order Code IE or IF

Class / Divisions:

FISCO for Class I, Division 1, Groups A, B, C, and D

FNICO for Class I Division 2, Groups A, B, C, and D

Temperature Code T4 $(-50\text{ °C} \leq T_a \leq 60\text{ °C})$

Single Seal; Enclosure Type 4X; Install per drawing 08800-0112

Class / Zones: IP66

Class I, Zone 0, AEx ia IIC T4 Ga

Temperature Code T4 $(-50\text{ °C} \leq T_a \leq 60\text{ °C})$

4-20 mA HART entity parameters	Fieldbus entity parameters	FISCO input parameters
$U_i = 30\text{ VDC}$	$U_i = 30\text{ VDC}$	$U_i = 17.5\text{ VDC}$
$I_i^* = 185\text{ mA}$	$I_i^* = 300\text{ mA}$	$I_i^* = 380\text{ mA}$
$P_i^* = 1.0\text{ W}$	$P_i^* = 1.3\text{ W}$	$P_i^* = 5.32\text{ W}$
$C_i = 0\text{ }\mu\text{F}$	$C_i = 0\text{ }\mu\text{F}$	$C_i = 0\text{ }\mu\text{F}$
$L_i = 0.97\text{ mH}$	$L_i < 10\text{ }\mu\text{H}$	$L_i < 10\text{ }\mu\text{H}$

* Total for transmitter

Combined North America Certifications K5, K6, or KB: Combination of E5 and I5 or E6 and I6.

CSA Certificate 70054084X - Special Conditions for Safe Use (X):

1. The Flowmeter shall be provided with special fasteners of property class A2-70 or A4-70.
2. For information regarding the dimensions of the flameproof joints the manufacturer shall be contacted.
3. When fitted with the 90V transient suppressors, the equipment is not capable of passing the 500V insulation test. This must be taken into account upon installation.
4. When the equipment is installed, precautions shall be taken to ensure the ambient temperature of the transmitter lies between -50 °C to +70°C, taking into account process fluid effects. If the ambient temperature is outside this range remote transmitters shall be used.
5. Units marked with “Warning: Electrostatic Charging Hazard” may use non-conductive paint thicker than 0.2mm. Precautions shall be taken to avoid ignition due to electrostatic charge on the enclosure.
6. The enclosure may be made from aluminum alloy and given a protective polyurethane paint finish; however, care should be taken to protect it from impact or abrasion when located in Zone 0. The polyurethane paint finish may constitute an electrostatic hazard and must only be cleaned with a damp cloth.

CSA Certificate 70054084X - Model Number Structure:

8800D-abcdefghi Vortex Flowmeter

a = Meter Style: F, W, D, E, R or T.

b = Line Size: 005 (0.5 inch) up to 120 (12 inch) and 140 (14 inch – reducer only).

c = Wetted Materials: S, H, C, L, or D

d = Flange/Alignment Ring Code: any two-digit alpha numeric characters

e = Sensor Process Temperature Range: N, E, or S

f = Conduit Entry and Housing Material: 1, 2, 3, 4, 5, 6, or 7

g = Transmitter Output: D, P, F, or C



h = Calibration: 0 or 1

i = Options: Any Alpha-Numeric characters representing product options up to forty-eight digits.

Includes Safety Approval Code Options E5, E6, I5, I6, IE, IF, K5, K6, KB or blank (ordinary location).

Rosemount 8800 Vortex Flow Meter ATEX / IECEx Flameproof Certifications

Flameproof enclosure 'Ex db' protection type in accordance with IEC 60079-1, EN 60079-1

-  Transmitters with Flameproof enclosure type protection shall only be opened when power is removed.
-  Closing of entries in the device must be carried out using the appropriate Ex d cable gland or blanking plug.
Housings with standard conduit entry thread forms are 1/2-14 NPT. Housings with optional thread form M20 x 1.5 are marked M20.

European Directive Information

The CE Declaration of Conformity for all applicable European directives for this product can be found on our website at www.emerson.com. A hard copy may be obtained by contacting our local sales office.

ATEX Directive

Emerson Automation Solutions complies with the ATEX Directive.

European Pressure Equipment Directive (PED)

Rosemount 8800D Vortex Flowmeter Line Size 40 mm to 300 mm

DNV GL Certificate Number 12317-2018-CE-USA-ACCREDIA

Module H Conformity Assessment

Mandatory CE-marking for flowmeters in accordance with Article 15 of the PED can be found on the flowtube body.

Flowmeter categories I – III use module H for conformity assessment procedures.

Rosemount 8800D Vortex Flowmeter Line Size 15 mm and 25 mm

Sound Engineering Practice (SEP)

Flowmeters that are SEP are outside the scope of PED and cannot be marked for compliance with PED.

Rosemount 8800 Vortex Flow Meter ATEX & IECEx Flameproof Certificate Summary

1. Equipment Markings – See individual certification information listed in this document
 - a. EU-Type Examination Certificates (ATEX):
DEKRA: KEMA99ATEX3852 X and Annex 1
 - b. Certificates of Conformity (IECEx):
DEKRA: IECEx KEM 05.0017X and Annex 1
2. Required Documentation:
 - a. 08800-AP02: Rosemount 8800D ATEX/IECEx Approvals Document
3. Referenced Documentation:
 - a. 00809-0100-4004; 8800D Reference Manual (HART).
 - b. 00825-0100-4004; 8800D Quick Start Guide.
 - c. 00809-0100-4772; 8800D Reference Manual (Fieldbus).
4. The Required and Referenced Documents listed above address the following items:
 - a. Instructions for safety i.e.
 - i. Putting into service
 - ii. Use
 - iii. Assembling and dismantling
 - iv. Maintenance, overhaul and repair
 - v. Installation
 - vi. Adjustment
 - b. Where necessary, training instructions.
 - c. Details which allow a decision to be made as to whether the equipment can be used safely in the intended area under the expected operating conditions.
 - d. Electrical parameters, maximum surface temperatures and other limit values
 - i. Electrical – see table below and individual certification information listed in this document
 - ii. Other parameters - Refer to individual certification information listed in this document

Rosemount 8800D Vortex Flow Meter: Electrical Input Ratings	
Power input	42 VDC Max; 4-20 mA HART, digital Pulse 32 VDC Max; Fieldbus
Um	250V

- e. Special Conditions for Safe Use (X): see individual certificates listed in this document.
- f. Where necessary, the essential characteristics of tools which may be fitted to the equipment:
 - i. No proprietary tools required.
- g. List of the standards, including the issue date, with which the equipment is declared to comply:
 - i. See details of individual certificates listed in this document.
- h. Supply wire requirements: Use 24 AWG or larger wire and do not exceed 5,000 feet (1,500 meters). For ambient temperatures above 140 °F (60 °C) use wire rated to 176 °F (80 °C) or higher.
- i. Contact Address: Emerson – Rosemount, Micro Motion Inc
12001 Technology Drive
Eden Prairie, MN 55344 USA

European Certifications

ATEX Flameproof: Order Code; E1

Combined ATEX Certifications: Order Code K1 - Combination of Order Codes E1, I1, N1, and ND

Certificate: KEMA99ATEX3852 X

Standards: EN 60079-0: 2012 + A11: 2013 EN 60079-1: 2014 EN 60079-11: 2012 EN 60079-26: 2015

Markings:

Integral Flowmeter marked: II 1/2 G		Ex db [ia] IIC T6...T1 Ga/Gb	(-50 °C ≤ Ta ≤ 70 °C)
Remote Transmitter marked: II 2(1) G		Ex db [ia Ga] IIC T6 Gb	(-50 °C ≤ Ta ≤ 70 °C)
Remote Meter Body marked: II 1 G		Ex ia IIC T6...T1 Ga	(-50 °C ≤ Ta ≤ 70 °C)

CE 2460

EPL Ga piezo sensor and thermocouple connections.

EPL Gb transmitter enclosure.

See Annex 1 to ATEX / IECEx Flameproof Certificates for Electrical and Thermal Data

International IECEx Certifications

IECEx Flameproof: Order Code; E7

Combined IECEx Certifications: Order Code K7 - Combination of Order Codes E7, I7, N7, and NF.

Certificate: IECEx KEM 05.0017X

Standards: IEC 60079-0: 2011 IEC 60079-1: 2014 IEC 60079-11: 2011 IEC 60079-26: 2014

Markings:

Integral Flowmeter marked:	Ex db [ia] IIC T6...T1 Ga/Gb	(-50 °C ≤ Ta ≤ 70 °C)
Remote Transmitter marked:	Ex db [ia Ga] IIC T6 Gb	(-50 °C ≤ Ta ≤ 70 °C)
Remote Meter Body marked:	Ex ia IIC T6...T1 Ga	(-50 °C ≤ Ta ≤ 70 °C)

EPL Ga piezo sensor and thermocouple connections.

EPL Gb transmitter enclosure.

See Annex 1 to ATEX / IECEx Flameproof Certificates for Electrical and Thermal Data

ATEX / IECEx Flameproof Certifications - Installation Instructions:

1. The cable and conduit entry devices shall be of a certified flameproof type Ex d, suitable for the conditions of use and correctly installed.
2. Unused apertures shall be closed with suitable blanking elements.
3. When the ambient temperature at the cable or conduit entries exceed 60 °C, cables suitable for at least 90 °C shall be used.
4. Remote mounted sensor; in type of protection Ex ia IIC, only to be connected to the associated Rosemount Model 8800D Vortex Flowmeter electronics. The maximum allowable length of the interconnecting cable is 152 m (500 ft).

ATEX / IECEx Flameproof Certifications - Special Conditions for Safe Use (X):

1. For information regarding the dimensions of the flameproof joints, the manufacturer shall be contacted.
2. The Flowmeter shall be provided with special fasteners of property class A2-70 or A4-70.
3. Units marked with "Warning: Electrostatic Charging Hazard" may use non-conductive paint thicker than 0.2 mm. Precaution shall be taken to avoid ignition due to electrostatic charge on the enclosure.
4. When the equipment is installed, precautions shall be taken to ensure the ambient temperature of the transmitter lies between -50°C to +70°C, taking into account process fluid effects. If the ambient temperature is outside this range remote transmitters shall be used.

Annex 1 to ATEX / IECEx Flameproof Certifications KEMA99ATEX3852 X and IECEx KEM 05.0017X

Thermal Data:

Ambient temperature range: -50 °C to +70 °C

Process temperature range: -200 °C to +427 °C

Temperature class – Transmitter: T6

Temperature class – Sensor: see table below

Ambient temperature (°C)	Process temperature (°C)	T-Class sensor
-50 to +70	-200 to +75	T6
-50 to +70	-200 to +95	T5
-50 to +70	-200 to +130	T4
-50 to +70	-200 to +195	T3
-50 to +70	-200 to +290	T2
-50 to +70	-200 to +427	T1

Electrical Data - Power Supply:

32 Vdc max (Fieldbus, digital output), Um = 250 V

42 Vdc max (4-20 mA HART analog and pulse outputs),

Um = 250 V

Model Type Designation

8800D E 6 D – – M5 A20 V5
I II III IV V VI VII VIII IX

Designation	Explanation	Value	Explanation
I	Model	8800D	Vortex flowmeter
II	Sensor temperature range	N E S	Standard: -40 °C to +232 °C Extended: -200 °C to +427 °C Severe service: -200 °C to + 427 °C
III	Conduit entry	1 2 6 7	½-14 NPT – aluminum housing M20x1.5 – aluminum housing ½-14 NPT – SST housing M20x1.5 – SST housing
IV	Output	D P F C	4-20 mA digital HART 4-20 mA digital HART with pulse FOUNDATION FIELDBUS One 4-20 mA digital HART with scaled output and one FOUNDATION FIELDBUS
V	Multivariable	MTA MPA MCA Blank	Multivariable output with temperature compensation with integral temperature sensor Multivariable output with pressure compensation Multivariable output with pressure and temperature compensation with integral temperature sensor No multivariable output
VI	Electrical connector	GN Blank	ATEX flameproof A size, mini connector (minifast) No connector
VII	Display	M5 Blank	LCD display No display
VIII	Remote Electronics	R10 R20 R30 R33 R50 Rxx A10 A20 A33 A50 A75 Blank	10 ft (3 m) cable 20 ft (6.1 m) cable 30 ft (9.1 m) cable 33 ft (10 m) cable 50 ft (15.2 m) cable Customer specified cable length, up to 75 ft (23 m) 10 ft (3 m) armored cable 20 ft (6.1 m) armored cable 33 ft (10 m) armored cable 50 ft (15.2 m) armored cable 75 ft (22.9 m) armored cable Integral mount electronics
IX	Ground screw	V5	External ground screw

Note: * Other types of protection that appear on the marking of the equipment are not relevant to this certificate.

Rosemount 8800 Vortex Flow Meter

ATEX / IECEx Intrinsically Safe, Type 'n', and Enclosure (Ex tb - Dust) Certifications

Type 'n' protection type in accordance with IEC 60079-15, EN 60079-15

 Closing of entries in the device must be carried out using the appropriate Ex e or Ex n cable gland and metal blanking plug or any appropriate ATEX or IECEx approved cable gland and blanking plug with IP66 rating certified by an EU approved certification body.

European Directive Information

The CE Declaration of Conformity for all applicable European directives for this product can be found on our website at www.emerson.com.
A hard copy may be obtained by contacting our local sales office.

ATEX Directive

Emerson Automation Solutions complies with the ATEX Directive.

European Pressure Equipment Directive (PED)

Rosemount 8800D Vortex Flowmeter Line Size 40 mm to 300 mm

DNV GL Certificate Number 12317-2018-CE-USA-ACCREDIA

Module H Conformity Assessment

Mandatory CE-marking for flowmeters in accordance with Article 15 of the PED can be found on the flowtube body.

Flowmeter categories I – III use module H for conformity assessment procedures.

Rosemount 8800D Vortex Flowmeter Line Size 15 mm and 25 mm

Sound Engineering Practice (SEP)

Flowmeters that are SEP are outside the scope of PED and cannot be marked for compliance with PED.

Rosemount 8800 Vortex Flow Meter

ATEX / IECEx Intrinsically Safe, Type 'n', and Enclosure (Ex tb-Dust) Certifications

1. Equipment Markings – See individual certification information listed in this document
 - a. EU-Type and Type Examination Certificates (ATEX):
Baseefa: Baseefa 05ATEX0084X, Baseefa 05ATEX0085X. Baseefa 17ATEX0020X
 - b. Certificates of Conformity (IECEx):
Baseefa: IECEx BAS 05.0028X, IECEx BAS 05.0029X, IECEx BAS 17.0019X
2. Required Documentation:
 - a. None
3. Referenced Documentation:
 - a. 00809-0100-4004; 8800D Reference Manual (HART).
 - b. 00825-0100-4004; 8800D Quick Start Guide.
 - c. 00809-0100-4772; 8800D Reference Manual (Fieldbus).
 - d. 08800-AP03: Approval Document
 - e. 00825-VA00-0001
4. The Required and Referenced Documents listed above address the following items:
 - a. Instructions for safety i.e.
 - i. Putting into service
 - ii. Use
 - iii. Assembling and dismantling
 - iv. Maintenance, overhaul and repair
 - v. Installation
 - vi. Adjustment
 - b. Where necessary, training instructions.
 - c. Details which allow a decision to be made as to whether the equipment can be used safely in the intended area under the expected operating conditions.
 - d. Electrical parameters, maximum surface temperatures and other limit values
 - i. Electrical – see table below and individual certification information listed in this document
 - ii. Other parameters - Refer to individual certification information listed in this document

Rosemount 8800D Vortex Flow Meter: Electrical Input Ratings	
<i>Power input</i>	<i>42 VDC Max; 4-20 mA HART, digital Pulse 32VDC Max; Fieldbus</i>
<i>Um</i>	<i>250V</i>

- e. Special Conditions for Safe Use (X): see individual certificates listed in this document.
- f. Where necessary, the essential characteristics of tools which may be fitted to the equipment:
 - i. No proprietary tools required.
- g. List of the standards, including the issue date, with which the equipment is declared to comply:
 - i. See details of individual certificates listed in this document.
- h. Supply wire requirements: Use 24 AWG or larger wire and do not exceed 5,000 feet (1,500 meters). For ambient temperatures above 140 °F (60 °C) use wire rated to 176 °F (80 °C) or higher.
- i. Contact Address: Emerson – Rosemount, Micro Motion Inc
12001 Technology Drive
Eden Prairie, MN 55344 USA

European Certifications



ATEX Intrinsic Safety Certification: Order Code; I1

Combined ATEX Certifications: Order Code K1 - Combination of Order Codes E1, I1, N1, and ND

Certificate: Baseefa05ATEX0084X

Standards: EN IEC 60079-0: 2018 EN 60079-11: 2012

ATEX Marking



 II 1 G Ex ia IIC T4 Ga (-60 °C ≤ Ta ≤ 70 °C) 4-20 mA HART
 II 1 G Ex ia IIC T4 Ga (-60 °C ≤ Ta ≤ 60 °C) Fieldbus
 2460

ATEX Intrinsic Safety FISCO Certification: Order Code; IA

Certificate: Baseefa05ATEX0084X

Standards: EN IEC 60079-0: 2018 EN 60079-11: 2012

ATEX Marking

 II 1 G Ex ia IIC T4 Ga (-60 °C ≤ Ta ≤ 60 °C) FISCO
 2460

4-20 mA HART entity parameters	Fieldbus entity parameters	FISCO input parameters
U _i = 30 VDC	U _i = 30 VDC	U _i = 17.5 VDC
I _i * = 185 mA	I _i * = 300 mA	I _i * = 380 mA
P _i * = 1.0 W	P _i * = 1.3 W	P _i * = 5.32 W
C _i = 0 μF	C _i = 0 μF	C _i = 0 μF
L _i = 0.97 mH	L _i < 10 μH	L _i < 10 μH

* Total for transmitter

Special Conditions for Safe Use (X):

1. When fitted with 90V transient suppressors (T1 option), the equipment is not capable of passing the 500V isolation test. This must be taken into account upon installation.
2. The enclosure may be made from aluminum alloy and given a protective polyurethane paint finish; however, care should be taken to protect it from impact or abrasion when located in Zone 0 environment. The polyurethane paint finish may constitute an electrostatic hazard and must only be cleaned with a damp cloth.
3. When the equipment is installed, particular precautions must be taken to ensure taking into account the effect of process fluid temperature, that the ambient temperature of the electrical housing of the equipment meets the marked protection type temperature range.



ATEX Type 'n' Certification: Order Code; N1

Combined ATEX Certifications: Order Code K1 - Combination of Order Codes E1, I1, N1, and ND

Certificate: Baseefa05ATEX0085X

Standards: EN IEC 60079-0: 2018 EN 60079-11: 2012 EN 60079-15: 2010

ATEX Marking

 II 3 G Ex nA ic IIC T5 Gc (-50 °C ≤ Ta ≤ 70 °C) 4-20 mA HART
 II 3 G Ex nA ic IIC T5 Gc (-50 °C ≤ Ta ≤ 60 °C) Fieldbus

Maximum Working Voltage = 42 VDC 4-20 mA HART

Maximum Working Voltage = 32 VDC Fieldbus

Special Conditions for Safe Use (X)

1. When fitted with 90V transient suppressors (T1 Option), the equipment is not capable of passing the 500V isolation test. This must be taken into account upon installation.
2. The enclosure may be made from aluminum alloy with a protective polyurethane paint finish. The polyurethane paint finish may constitute and electrostatic hazard and must only be cleaned with a damp cloth.
3. When the equipment is installed, particular precautions must be taken to ensure, taking into account the effect of process fluid temperature, that the ambient temperature of the electrical housing of the equipment meets the marked protection type temperature range.

ATEX Protection by Enclosure (Ex tb) (Dust) Certification: Order Code; ND

Combined ATEX Certifications: Order Code K1 - Combination of Order Codes E1, I1, N1, and ND

Certificate: Baseefa17ATEX0020X

Standards: EN IEC 60079-0: 2018 EN 60079-31: 2014

Certificate: BaseefaATEX17.0020X

ATEX Marking:

 II 2 D Ex tb IIIC T85°C Db (-20 °C ≤ Ta ≤ 70 °C)

 2460

Maximum Working Voltage = 42 VDC 4-20 mA HART

Maximum Working Voltage = 32 VDC Fieldbus

Special Conditions for Safe Use (X):

1. The enclosure may be made from aluminium alloy with a protective polyurethane paint finish which may constitute a potential electrostatic ignition risk. Care should be taken to protect it from external conditions conducive to the build-up of electrostatic charge on such surfaces. The enclosure must not be rubbed or cleaned with a dry cloth.
2. When the equipment is installed, particular precautions must be taken to ensure, taking into account the effect of process fluid temperature, that the ambient temperature of the electrical housing of the equipment meets the marked protection type temperature range.

IECEx International Certifications

IECEx Intrinsic Safety Certification: Order Code; I7

Combined IECEx Certifications: Order Code K7 - Combination of Order Codes E7, I7, N7, and NF

Certificate: IECEx BAS 05.0028X

Standards: IEC 60079-0: 2017 IEC 60079-11: 2011

IECEx Marking:

Ex ia IIC T4 Ga (-60 °C ≤ Ta ≤ 70 °C); 4-20 mA HART

Ex ia IIC T4 Ga (-60 °C ≤ Ta ≤ 60 °C); Fieldbus

IECEx FISCO Certification: Order Code; IG

IG Certificate: IECEx BAS 05.0028X

IECEx Marking:

Ex ia IIC T4 Ga (-60 °C ≤ Ta ≤ 60 °C) FISCO

4-20 mA HART entity parameters	Fieldbus entity parameters	FISCO input parameters
U _i = 30 VDC	U _i = 30 VDC	U _i = 17.5 VDC
I _i * = 185 mA	I _i * = 300 mA	I _i * = 380 mA
P _i * = 1.0 W	P _i * = 1.3 W	P _i * = 5.32 W
C _i = 0 μF	C _i = 0 μF	C _i = 0 μF
L _i = 0.97 mH	L _i < 10 μH	L _i < 10 μH

* Total for transmitter

Special Conditions for Safe Use (X):

1. When fitted with 90V transient suppressors (T1 Option), the equipment is not capable of passing the 500V isolation test. This must be taken into account upon installation.
2. The enclosure may be made from aluminum alloy and given a protective polyurethane paint finish; however, care should be taken to protect it from impact or abrasion when located in Zone 0 environment. The polyurethane paint finish may constitute an electrostatic hazard and must only be cleaned with a damp cloth.
3. When the equipment is installed, particular precautions must be taken to ensure, taking into account the effect of process fluid temperature, that the ambient temperature of the electrical housing of the equipment meets the marked protection type temperature range.

IECEX Type 'n' Certification: Order Code; N7

Combined IECEx Certifications: Order Code K7 - Combination of Order Codes E7, I7, N7, and NF

Certificate: IECEx BAS05.0029X

Standards: IEC 60079-0: 2017 IEC 60079-11: 2011 IEC 60079-15: 2010

IECEX Marking:

Ex nA ic IIC T5 Gc (-50 °C ≤ Ta ≤ 70 °C); 4-20 mA HART

Ex nA ic IIC T5 Gc (-50 °C ≤ Ta ≤ 60 °C); Fieldbus

Maximum Working Voltage = 42 VDC; 4-20 mA HART

Maximum Working Voltage = 32 VDC; Fieldbus

Special Conditions for Safe Use (X):

1. When fitted with 90V transient suppressors (T1 Option), the equipment is not capable of passing the 500V isolation test. This must be taken into account upon installation.
2. The enclosure may be made from aluminum alloy with a protective polyurethane paint finish. The polyurethane paint finish may constitute an electrostatic hazard and must only be cleaned with a damp cloth.
3. When the equipment is installed, particular precautions must be taken to ensure, taking into account the effect of process fluid temperature, that the ambient temperature of the electrical housing of the equipment meets the marked protection type temperature range.

IECEX Protection by Enclosure (Ex tb) (Dust) Certification: Order Code; NF

Combined IECEx Certifications: Order Code K7 - Combination of Order Codes E7, I7, N7, and NF

Certificate: IECEx BAS 17.0019X

Standards: IEC 60079-0: 2017 IEC 60079-31: 2013

IECEX Marking:

Ex tb IIIC T85°C Db (-20 °C ≤ Ta ≤ 70 °C)

Maximum Working Voltage = 42 VDC 4-20 mA HART

Maximum Working Voltage = 32 VDC Fieldbus

Special Conditions for Safe Use (X):

1. The enclosure may be made from aluminium alloy with a protective polyurethane paint finish which may constitute a potential electrostatic ignition risk. Care should be taken to protect it from external conditions conducive to the build-up of electrostatic charge on such surfaces. The enclosure must not be rubbed or cleaned with a dry cloth.
2. When the equipment is installed, particular precautions must be taken to ensure, taking into account the effect of process fluid temperature, that the ambient temperature of the electrical housing of the equipment meets the marked protection type temperature range.



EU Declaration of Conformity No: RFD 1029 Rev. X

We,

**Emerson – Rosemount, Micro Motion Inc.
12001 Technology Drive
Eden Prairie, MN 55344
USA**

declare under our sole responsibility that the product(s),

Rosemount Model 8800D Vortex Flowmeters

to which this declaration relates, is in conformity with the provisions of the European Union Legislation, including the latest amendments, as shown in the attached schedule.

Assumption of conformity is based on the application of harmonized or applicable technical standards and, when applicable or required, a European Union Legislation notified body certification, as shown in the attached schedule.

(signature)

09 April 2019

(date of issue)

Mark Fleigle

(name - printed)

Vice President - Technology and Product Development

(function name - printed)



Schedule
EU Declaration of Conformity: RFD 1029 Rev. X

EMC Directive 2014/30/EU:

All Models – EN 61326-1: 2013

PED Directive 2014/68/EU:

Model 8800D Vortex Flowmeter with option 'PD', in Line Sizes 1.5" - 12"

Equipment without the 'PD' option is NOT PED compliant and cannot be used in the EEA without further assessment unless the installation is exempt under Article 1, paragraph 2 of the PED Directive 2014/68/EU.

QS Certificate of Assessment - 12317-2018-CE-USA-ACCREDIA
Module H Conformity Assessment - ASME B31.3: 2016

Model 8800D Vortex Flowmeter with option 'PD', in Line Sizes .5" - 1"
Sound Engineering Practice - ASME B31.3: 2016

ATEX Directive 2014/34/EU: Model 8800D Vortex Flowmeter

Baseefa05ATEX0084 X – Intrinsic Safety Certificate
Equipment Group II, Category 1 G (Ex ia IIC T4 Ga)
EN IEC 60079-0: 2018 EN 60079-11: 2012

Baseefa05ATEX0085 X – Type n Certificate
Equipment Group II, Category 3 G (Ex nA ic IIC T5 Gc)
EN IEC 60079-0: 2018 EN 60079-11: 2012 EN 60079-15: 2010

Baseefa17ATEX0020X – Protection by Enclosure 'tb' Certificate
Equipment Group II, Category 2 D (Ex tb IIIC T85°C Db)
EN IEC 60079-0: 2018 EN 60079-31: 2014

KEMA99ATEX3852X – Flameproof with Intrinsically Safe Connection(s) Certificate
Equipment Group II, Category 1/2 G (Ex db [ia] IIC T6...T1 Ga/Gb) – Integral Transmitter
Equipment Group II, Category 2(1) G (Ex db [ia Ga] IIC T6 Gb) – Remote Transmitter
Equipment Group II, Category 1 G (Ex ia IIC T6...T1 Ga) – Remote Sensor
EN 60079-0: 2012 + A11: 2013 EN 60079-1: 2014 EN 60079-11: 2012 EN 60079-26: 2015



Schedule
EU Declaration of Conformity: RFD 1029 Rev. X

PED Notified Body

DNV GL Business Assurance S.r.l. [Notified Body Number: 0496]
Via Energy Park 14
Vimercate, 20871 Italy

ATEX Notified Bodies

DEKRA Certification B.V. [Notified Body Number: 0344]
Meander 1051, 6825 MJ Arnhem
P.O. Box 5185, 6802 ED Arnhem
The Netherlands

SGS Baseefa Limited [Notified Body Number: 1180]
Rockhead Business Park, Staden Lane
Buxton, Derbyshire SK17 9RZ
United Kingdom

ATEX Notified Body for Quality Assurance

DNV Nemko Presafe AS [Notified Body number: 2460]
P.O. Box 73, Blindern
0314 Oslo, Norway

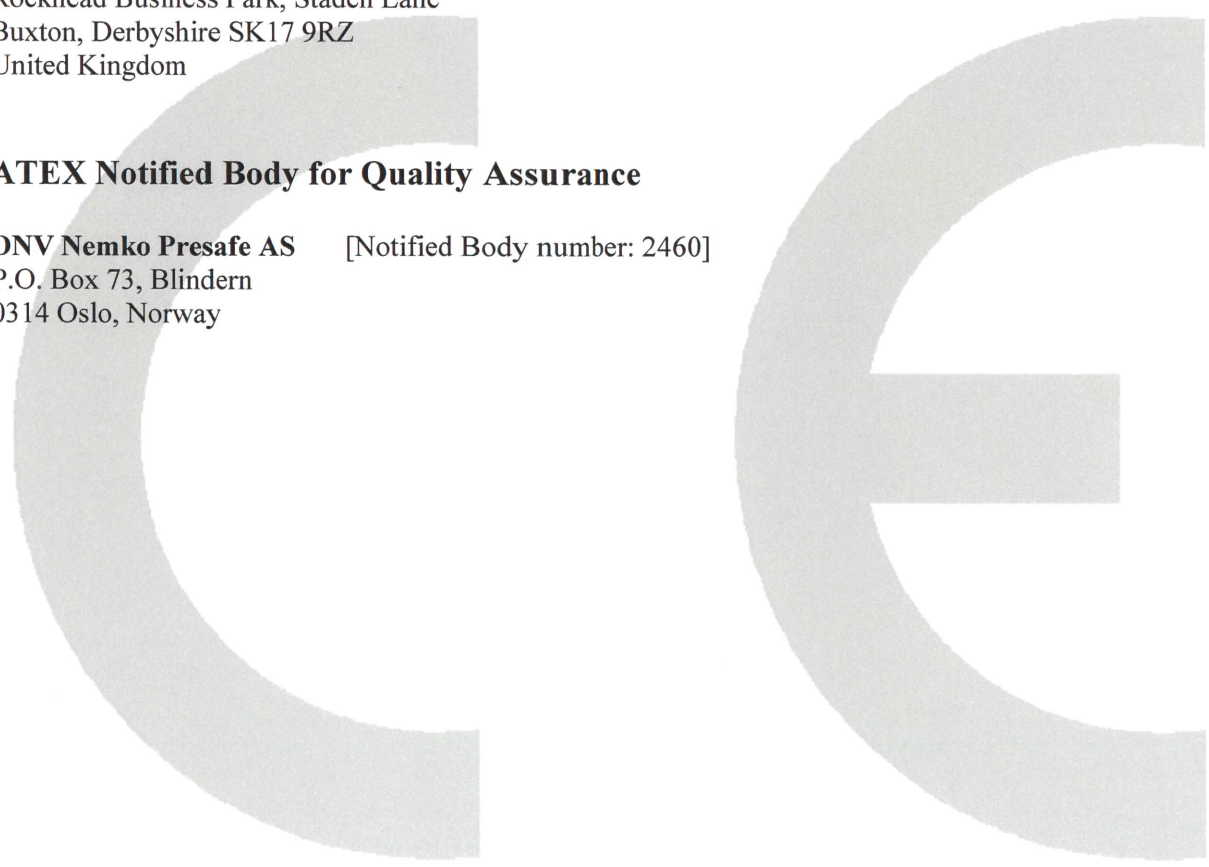

PAGE	DESCRIPTION/PROTECTION TYPE
1	TABLE OF CONTENTS
2	NON-INCENDIVE FIELD WIRING
3	HART OUTPUT; INTRINSICALLY SAFE
4	FIELD BUS OUTPUT; INTRINSICALLY SAFE
5	FIELD BUS OUTPUT; INTRINSICALLY SAFE FISCO CONCEPT
6	FIELD BUS OUTPUT; NON-INCENDIVE CONCEPT FNICO CONCEPT
7	REPLACEMENT OF FM MARKED 8800D TRANSMITTERS WITH EQUIVALENT CSA MODEL CODE
8	Ex d - FLAMEPROOF INSTALLATION FOR CLASS I, ZONE 1.

NOTES:

- COMPONENTS REQUIRED TO HAVE HAZARDOUS LOCATION APPROVAL MUST BE APPROVED FOR THE GAS GROUP APPROPRIATE TO AREA CLASSIFICATION.
- ASSOCIATED APPARATUS MANUFACTURER'S INSTALLATION DRAWING MUST BE FOLLOWED WHEN INSTALLING THIS EQUIPMENT.
- DUST-TIGHT CONDUIT SEAL MUST BE USED WHEN INSTALLED IN CLASS II AND CLASS III ENVIRONMENTS.
- TRANSMITTER MUST NOT BE CONNECTED TO EQUIPMENT GENERATING MORE THAN 250VAC.
- RESISTANCE BETWEEN INTRINSICALLY SAFE GROUND AND EARTH GROUND MUST BE LESS THAN 1 OHM.
- USA - INSTALLATION SHOULD BE IN ACCORDANCE WITH THE NATIONAL ELECTRICAL CODE (NEC), NFPA-70, AND ANSI/ISA-RP12.06.01. "INSTALLATION OF INTRINSICALLY SAFE SYSTEMS FOR HAZARDOUS (CLASSIFIED) LOCATIONS" CANADA - INSTALLATION SHOULD BE IN ACCORDANCE WITH THE CANADIAN ELECTRICAL CODE PART 1 (C22.1)
- THE ASSOCIATED APPARATUS MUST BE APPROVED FOR THE GAS GROUP APPROPRIATE TO AREA CLASSIFICATION.
- ⚠** WARNING - SUBSTITUTION OF COMPONENTS MAY IMPAIR INTRINSIC AND NON-INCENDIVE SAFETY.

⚠ ASSOCIATED APPARATUS MUST MEET THE FOLLOWING PARAMETERS:

U_o or V_o or $V_t \leq U_i$ (Vmax) $C_a \geq$ THE SUM OF ALL C_i 's PLUS C_{cable}
 I_o or I_{sc} or $I_t \leq I_i$ (Imax) $L_a \geq$ THE SUM OF ALL L_i 's PLUS L_{cable}
 P_o or $P_{max} \leq (P_{max})$
- ⚠** WARNING - TO PREVENT IGNITION OF FLAMMABLE OR COMBUSTIBLE ATMOSPHERES, DISCONNECT POWER BEFORE SERVICING.

⚠ WARNING - IN EXPLOSIVE ATMOSPHERE KEEP TIGHT WHEN CIRCUIT ALIVE

⚠ AVERTISSEMENT: DANS UNE ATMOSPHERE EXPLOSIBLE GARDNER BIEN FERME LORSQUE LE CIRCUIT EST SOUS TENSION

⚠ WARNING - UNDERSTAND MANUAL BEFORE OPERATING

⚠ AVERTISSEMENT: LIRE ATTENTIVE LES INSTRUCTIONS AVANT DEMETTRE EN MARCHÉ
- THIS EQUIPMENT IS NOT CAPABLE OF PASSING THE 500V ISOLATION TEST DUE TO INTEGRAL TRANSIENT PROTECTION. THIS MUST BE TAKEN INTO ACCOUNT UPON INSTALLATION.
- WIRING METHOD SUITABLE FOR APPROPRIATE CLASS AND DIVISION OR ZONE AND PROTECTION TYPE.
- THE INTRINSICALLY SAFE 4-20MA OUTPUT MUST USE TWISTED PAIR WITH AN INDIVIDUAL SHIELD FOR THE PAIR. IT IS ALSO RECOMMENDED TO USE SHIELDED TWISTED PAIR FOR PULSE OUTPUT.
- NO REVISION TO THIS DRAWING WITHOUT PRIOR APPROVAL.

REVISION TABLE			
REVISION	ECO NO.	APP'D	DATE
AE	1084-104	M.M.	7/2/18

DESCRIPTION

UPDATE PAGE 7 TABLE TO INCLUDE FM CODES IN CSA COLUMN. UPDATE PAGE 8.

08800-0112

DRAWING NO.

CONFIDENTIAL AND PROPRIETARY INFORMATION IS CONTAINED HEREIN AND MUST BE HANDLED ACCORDINGLY.	SURFACE FINISH UNLESS OTHERWISE SPECIFIED	125°	3RD ANGLE	SIZE	SCALE	REV
UNLESS OTHERWISE SPECIFIED DIMENSIONS IN INCHES (mm). REMOVE ALL BURRS AND SHARP EDGES.				C	-	AE
.X ± .1 12.51						
.XX ± .02 10.51						
.XXX ± .010 10.251						
FRACTIONS ± 1/32						
ANGLES ± 2'						

EMERSON
 TITLE: INSTALLATION DRAWING FOR:
 MODEL 8800D AND 8600D CSA /S INSTALLATION OR NON-INCENDIVE FIELD WIRING INSTALLATION APPROVAL FOR HART AND FIELD BUS
 DR. N. BOND 6-25-15 DRAWING NO. 08800-0112
 APP'D

DO NOT SCALE PRINT CAD MAINTAINED. (PRO/E) PRODUCT CODE SHEET 1 OF 8

NONINCENDIVE FIELD WIRING

NONINCENDIVE FIELD WIRING
CLASS 1, DIV. 2 LOCATIONS

NON-CLASSIFIED
LOCATION

HAZARDOUS (CLASSIFIED) LOCATION
CLASS 1, DIV. 2, GRP'S A, B, C, D

V_{max1} C11 LI1
 V_{max2} C12 LI2
 V_{max3} C13 LI3
 V_{maxN} C1N LIN

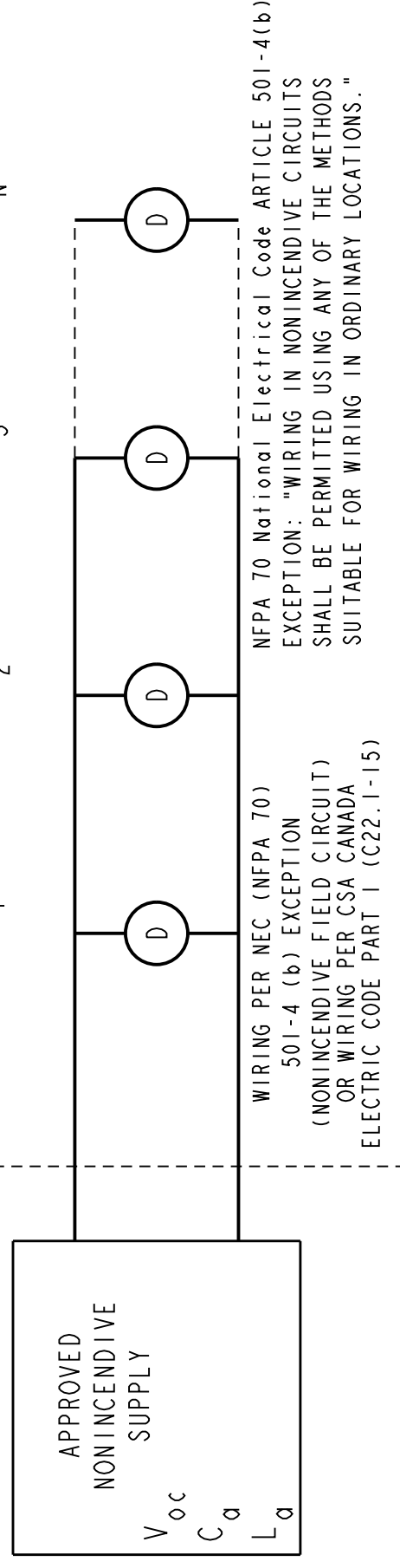

IN NORMAL OPERATION

DEVICES CONTROL THROUGH-CURRENT

PARAMETERS
(NON-INCENDIVE
FIELD WIRING)

8800D OR 8600D 4-20mA / HART	
V_{max}	42.4V
MAXIMUM NORMAL OPERATING CURRENT	22mA
C_i	0 μ F
L_i	970 μ H

ROSEMOUNT 8800D OR 8600D TRANSMITTERS ARE CURRENT CONTROLLERS ON INDIVIDUAL PARALLEL BRANCHES WITH RESPECT TO THE POWER SUPPLY. IN NONINCENDIVE INSTALLATIONS THE I_{max} FOR EACH TRANSMITTER IS NOT RELATED TO THE MAXIMUM CURRENT OF THE POWER SUPPLY (I_{sc}) IN THE SAME MANNER AS FOR TRANSMITTER INSTALLED PER I.S. REQUIREMENTS, BECAUSE NONINCENDIVE REQUIREMENTS INCLUDE ONLY NORMAL OPERATING CONDITIONS.

$$I_{maxN} > = I_{qN} + I_{signalN}$$

$$I_{max} \text{ FOR AN INDIVIDUAL DEVICE} = I_q + I_{signal}$$

$$I_q = \text{QUIESCENT CURRENT THROUGH DEVICE}$$

(MAXIMUM QUIESCENT CURRENT FOR THE DEVICE)

$$I_{signal} = \text{SIGNALING CURRENT THROUGH DEVICE}$$

(PROTOCOL MAY LIMIT SIGNALING TO ONE DEVICE AT A TIME)

$$\text{OPERATING } I_{max} = I_{q1} + I_{q2} + \dots + I_{qN} + I_{signal} \text{ MAX}$$

$$I_{signal} \text{ MAX} = \text{MAX OF } (I_{signal1}, I_{signal2}, \dots, I_{signalN})$$

TEMP CODE: T4 ($T_a = +70^\circ\text{C}$)

CONFIDENTIAL AND PROPRIETARY
INFORMATION IS CONTAINED HEREIN
AND MUST BE HANDLED ACCORDINGLY.

UNLESS OTHERWISE SPECIFIED
DIMENSIONS IN INCHES (mm). REMOVE
ALL BURRS AND SHARP EDGES.

-DEC TOLERANCES-
.X \pm .1 (2.51)
.XX \pm .02 (0.51)
.XXX \pm .010 (0.251)
FRACTIONS ANGLES
 \pm 1/32 \pm 2'

SURFACE FINISH UNLESS
OTHERWISE SPECIFIED

125°

3RD ANGLE

SIZE

SCALE

REV

AE

ROSEMOUNT

EMERSON

INSTALLATION DRAWING FOR:
MODEL 8800D OR 8600D CSA T.S. INSTALLATION OR
NON-INCENDIVE FIELD WIRING INSTALLATION
APPROVAL FOR HART AND FIELDBUS

DR. N. BOND 6-25-15 DRAWING NO.

APP'D.

PRODUCT CODE

DOC TYPE

SHEET 2 OF 8

(HART ONLY)

ROSEMOUNT MODEL 8800D OR 8600D CSA INTRINSIC SAFETY APPROVAL
 CIRCUIT CONNECTION WITH CSA APPROVED INTRINSIC SAFETY BARRIER(S).
 Ex ia
 INTRINSICALLY SAFE / SECURITE INTRINSEQUE

ENTITY PARAMETERS

TERMINALS "+", "-", AND "4-20mA"	ASSOCIATED APPARATUS PARAMETERS
V _{max} = 30Vdc	V _{oc} OR V _t ≤ 30V
I _{max} = 185mA	I _{sc} OR I _t ≤ 185mA
C _i = 0uF	C _a > C _{cable} + C _i
L _i = 970uH	L _a > L _{cable} + L _i

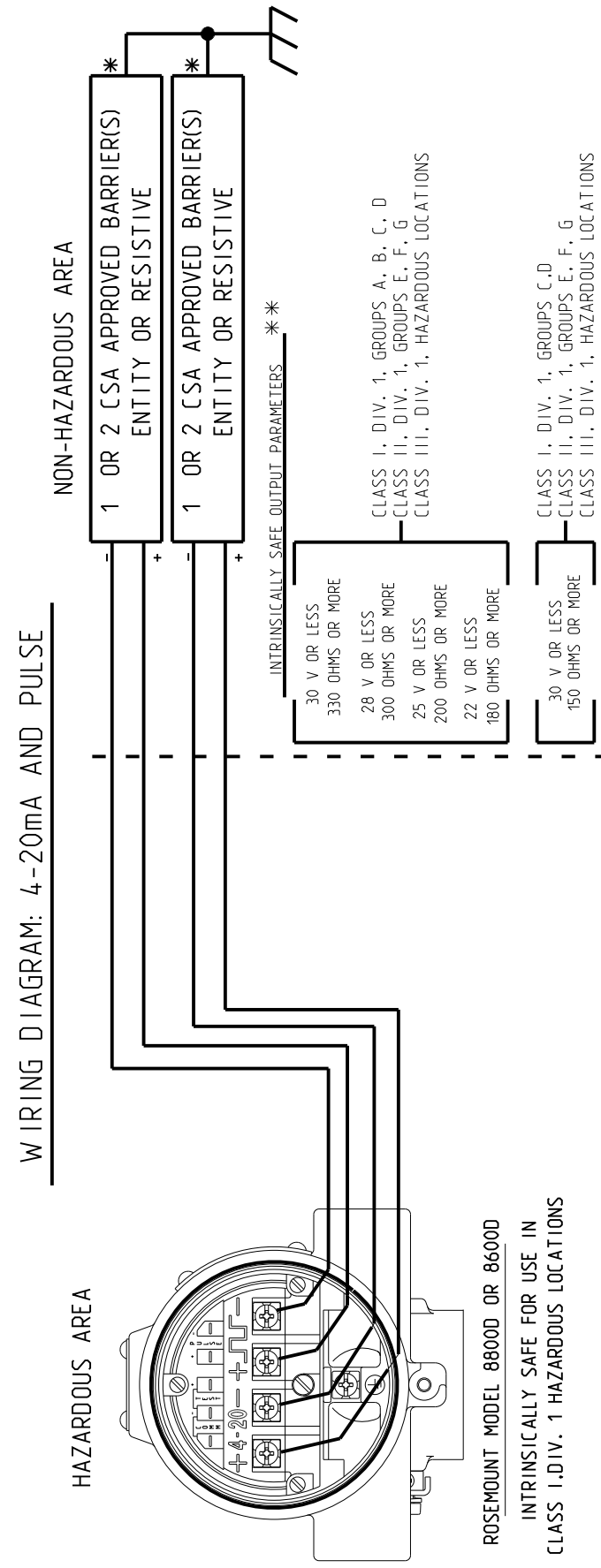
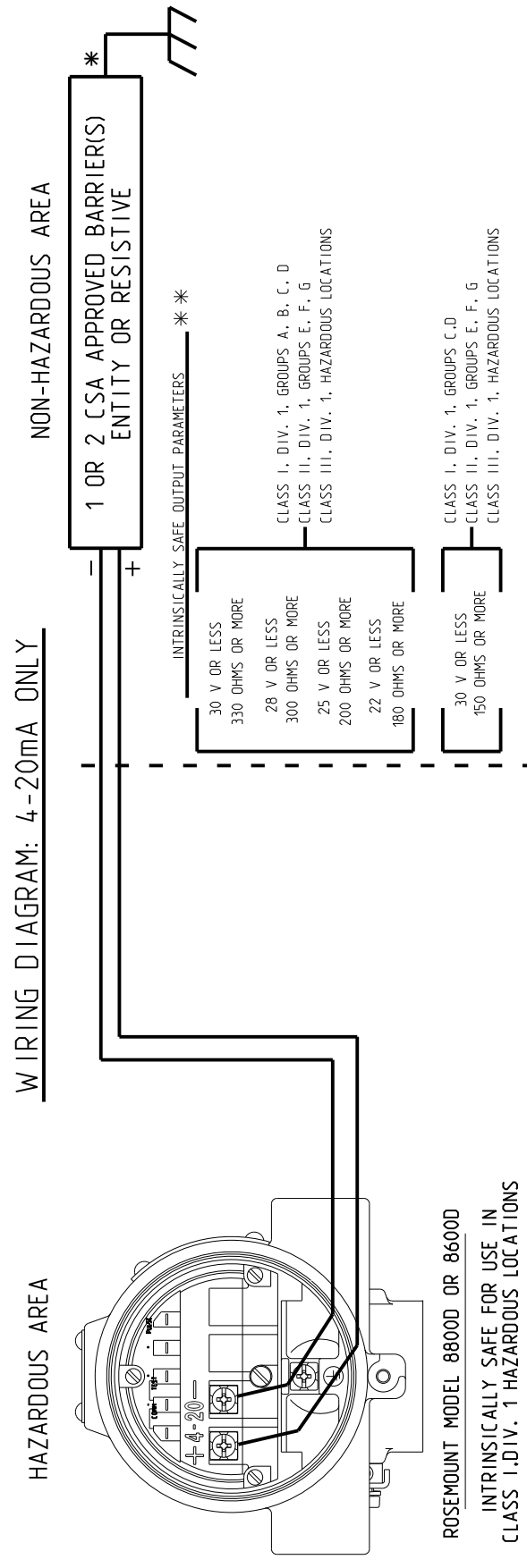

WARNING: SUBSTITUTION OF COMPONENTS MAY IMPAIR INTRINSIC SAFETY.
AVERTISSEMENT: La Substitution de composants peut compromettre la securite intrinseque.

SPECIAL CONDITIONS (X-CONDITIONS) FOR CLASS / ZONE INSTALLATIONS:

1. WHEN FITTED WITH 90V TRANSIENT SUPPRESSORS, THE EQUIPMENT IS NOT CAPABLE OF PASSING THE 500V INSULATION TEST. THIS MUST BE TAKEN INTO ACCOUNT UPON INSTALLATION.
2. THE ENCLOSURE MAY BE MADE FROM ALUMINUM ALLOY AND GIVEN A PROTECTIVE POLYURETHANE PAINT FINISH; HOWEVER, CARE SHOULD BE TAKEN TO PROTECT IT FROM IMPACT OR ABRASION WHEN LOCATED IN ZONE 0. THE POLYURETHANE PAINT FINISH MAY CONSTITUTE AN ELECTROSTATIC HAZARD AND MUST ONLY BE CLEANED WITH DAMP CLOTH.
3. WHEN THE EQUIPMENT IS INSTALLED, PARTICULAR PRECAUTIONS MUST BE TAKEN TO ENSURE, TAKING INTO ACCOUNT THE EFFECT OF PROCESS FLUID TEMPERATURE, THAT THE AMBIENT TEMPERATURE OF THE ELECTRICAL HOUSING OF THE EQUIPMENT MEETS THE MARKED PROTECTION TYPE TEMPERATURE RANGE.

HART INTRINSIC SAFETY

* ALL LINES CONNECTED TO THE MODEL 8800D OR 8600D MUST BE TERMINATED BY EITHER A CSA APPROVED BARRIER OR AN I.S. SAFETY GROUND.

* WHEN USING MORE THAN ONE CHANNEL OF A CSA APPROVED BARRIER, THE EFFECTIVE VOLTAGE AND RESISTANCE OF THE COMBINED LINES MUST COMPLY WITH THE LISTED INTRINSICALLY SAFE OUTPUT PARAMETERS. THE EFFECTIVE VOLTAGE AND RESISTANCE ARE TO BE CALCULATED AS FOLLOWS:

VOLTAGE: EFFECTIVE VOLTAGE = HIGHEST BARRIER VOLTAGE
 (NOTE: BOTH LINES MUST BE REFERENCED TO A COMMON GROUND)

RESISTANCE: EFFECTIVE RESISTANCE = PARALLEL COMBINATION OF EACH LINE
 (NOTE: DIODE RETURNS DO NOT NEED TO BE INCLUDED FOR THIS CALCULATION)

EXAMPLE #1:

BARRIER 1: VOLTAGE = 28V; RESISTANCE = 330 OHMS
 BARRIER 2: VOLTAGE = 28V; RESISTANCE = 330 OHMS
 EFFECTIVE VOLTAGE = 28V
 EFFECTIVE RESISTANCE = $R_1 R_2 / (R_1 + R_2) = 165$ OHMS

RESULT: THIS BARRIER COMBINATION WOULD BE ACCEPTABLE FOR GROUPS C, D SINCE THE EFFECTIVE VOLTAGE IS LESS THAN OR EQUAL TO 30V AND THE EFFECTIVE RESISTANCE IS GREATER THAN OR EQUAL TO 150 OHMS.

EXAMPLE #2:

BARRIER 1: VOLTAGE = 28V; RESISTANCE = 330 OHMS (4-20 "+")
 BARRIER 2: 28V DIODE RETURN (4-20 "-")
 BARRIER 3: VOLTAGE = 28V; RESISTANCE = 1000 OHMS (PULSE "+")
 BARRIER 4: 28V DIODE RETURN (PULSE "-")
 EFFECTIVE VOLTAGE = 28V
 EFFECTIVE RESISTANCE = $R_1 R_3 / (R_1 + R_3) = 248$ OHMS

RESULT: THIS BARRIER COMBINATION WOULD BE ACCEPTABLE FOR GROUPS C, D SINCE THE EFFECTIVE VOLTAGE IS LESS THAN OR EQUAL TO 30V AND THE EFFECTIVE RESISTANCE IS GREATER THAN OR EQUAL TO 150 OHMS.



WARNING: SUBSTITUTION OF COMPONENTS MAY IMPAIR INTRINSIC SAFETY.
AVERTISSEMENT: La Substitution de composants peut compromettre la securite intrinseque.

SPECIAL CONDITIONS (X-CONDITIONS) FOR CLASS / ZONE INSTALLATIONS:

1. WHEN FITTED WITH 90V TRANSIENT SUPPRESSORS, THE EQUIPMENT IS NOT CAPABLE OF PASSING THE 500V INSULATION TEST. THIS MUST BE TAKEN INTO ACCOUNT UPON INSTALLATION.
2. THE ENCLOSURE MAY BE MADE FROM ALUMINUM ALLOY AND GIVEN A PROTECTIVE POLYURETHANE PAINT FINISH; HOWEVER, CARE SHOULD BE TAKEN TO PROTECT IT FROM IMPACT OR ABRASION WHEN LOCATED IN ZONE 0. THE POLYURETHANE PAINT FINISH MAY CONSTITUTE AN ELECTROSTATIC HAZARD AND MUST ONLY BE CLEANED WITH DAMP CLOTH.
3. WHEN THE EQUIPMENT IS INSTALLED, PARTICULAR PRECAUTIONS MUST BE TAKEN TO ENSURE, TAKING INTO ACCOUNT THE EFFECT OF PROCESS FLUID TEMPERATURE, THAT THE AMBIENT TEMPERATURE OF THE ELECTRICAL HOUSING OF THE EQUIPMENT MEETS THE MARKED PROTECTION TYPE TEMPERATURE RANGE.

CONFIDENTIAL AND PROPRIETARY INFORMATION IS CONTAINED HEREIN AND MUST BE HANDLED ACCORDINGLY.

UNLESS OTHERWISE SPECIFIED DIMENSIONS IN INCHES (mm). REMOVE ALL BURRS AND SHARP EDGES.

-DEC TOLERANCES-
 .X ± .1 12.5I
 .XX ± .02 10.5I
 .XXX ± .010 10.25I
 FRACTIONS ANGLES
 ± 1/32 ± 2'

SURFACE FINISH UNLESS OTHERWISE SPECIFIED
 125°
 3RD ANGLE

SIZE C
 SCALE -
 REV AE

EMERSON
 TITLE
 MODEL 8800D OR 8600D CSA I.S. INSTALLATION OR NON-INCENDIVE FIELD WIRING INSTALLATION APPROVAL FOR HART AND FIELDBUS

ROSEMOUNT
 INSTALLATION DRAWING FOR:
 MODEL 8800D OR 8600D CSA I.S. INSTALLATION OR NON-INCENDIVE FIELD WIRING INSTALLATION APPROVAL FOR HART AND FIELDBUS

DR. N. BOND 6-25-15 DRAWING NO. 08800-0112
 APP'D.
 DO NOT SCALE PRINT CAD MAINTAINED. (PRO/E) PRODUCT CODE SHEET 3 OF 8

08800-0112
 DRAWING NO.

FIELDBUS INTRINSIC SAFETY

(FIELDBUS ONLY)

ROSEMOUNT MODEL 8800D OR 8600D CIRCUIT CONNECTION WITH CSA APPROVED INTRINSIC SAFETY BARRIER(S).
 CSA INTRINSIC SAFETY APPROVAL
 Ex ia
 Intrinsically Safe/Securite Intrinsic

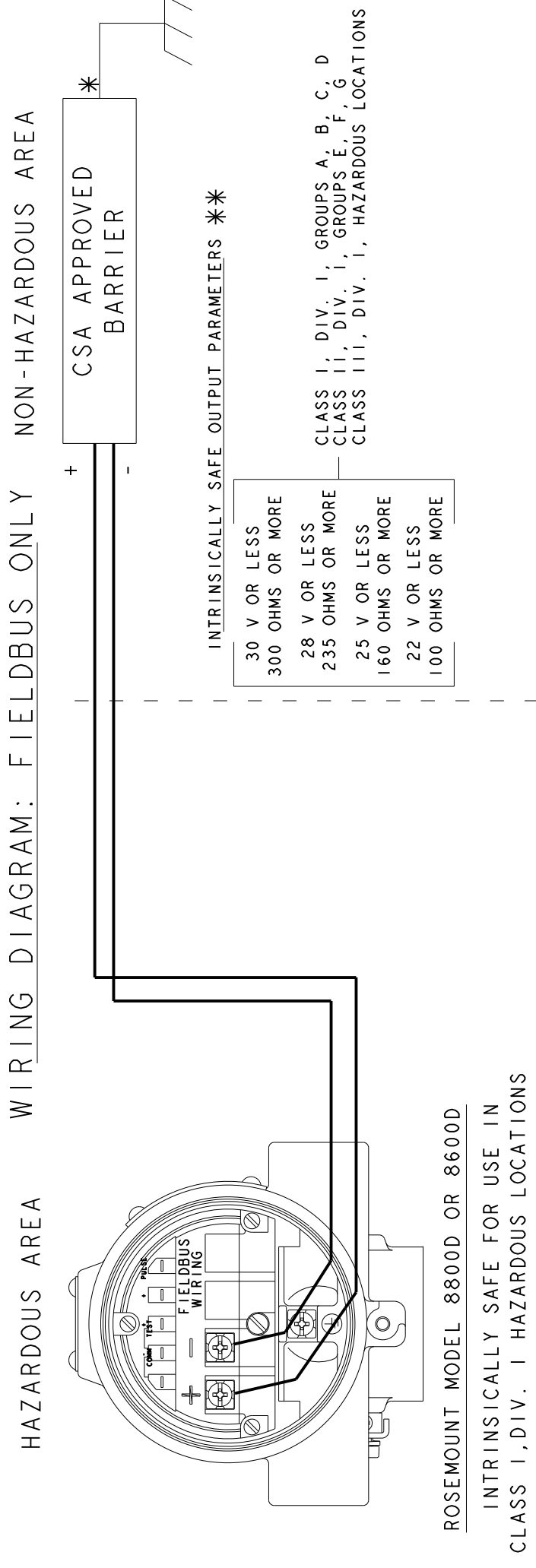

WARNING: SUBSTITUTION OF COMPONENTS MAY IMPAIR INTRINSIC SAFETY.
 AVERTISSEMENT: La Substitution de composants peut compromettre la securite intrinseque.

SPECIAL CONDITIONS (X-CONDITIONS) FOR CLASS / ZONE INSTALLATIONS:

1. WHEN FITTED WITH 90V TRANSIENT SUPPRESSORS, THE EQUIPMENT IS NOT CAPABLE OF PASSING THE 500V INSULATION TEST. THIS MUST BE TAKEN INTO ACCOUNT UPON INSTALLATION.
2. THE ENCLOSURE MAY BE MADE FROM ALUMINUM ALLOY AND GIVEN A PROTECTIVE POLYURETHANE PAINT FINISH; HOWEVER, CARE SHOULD BE TAKEN TO PROTECT IT FROM IMPACT OR ABRASION WHEN LOCATED IN ZONE 0. THE POLYURETHANE PAINT FINISH MAY CONSTITUTE AN ELECTROSTATIC HAZARD AND MUST ONLY BE CLEANED WITH DAMP CLOTH.
3. WHEN THE EQUIPMENT IS INSTALLED, PARTICULAR PRECAUTIONS MUST BE TAKEN TO ENSURE, TAKING INTO ACCOUNT THE EFFECT OF PROCESS FLUID TEMPERATURE, THAT THE AMBIENT TEMPERATURE OF THE ELECTRICAL HOUSING OF THE EQUIPMENT MEETS THE MARKED PROTECTION TYPE TEMPERATURE RANGE.

08800-0112

DRAWING NO.

REV AE

SCALE -

SIZE C

3RD ANGLE

125°

SURFACE FINISH UNLESS OTHERWISE SPECIFIED

EMERSON

INSTALLATION DRAWING FOR:
 MODEL 8800D OR 8600D CSA I.S. INSTALLATION OR
 NON-INCENDIVE FIELD WIRING INSTALLATION
 APPROVAL FOR HART AND FIELDBUS

DR. N. BOND

APP'D. 6-25-15

PRODUCT CODE

DOC TYPE

SHEET 4 OF 8

08800-0112

FIELDBUS INTRINSIC SAFETY FISCO CONCEPT

FISCO CONCEPT

THE FISCO CONCEPT ALLOWS INTERCONNECTION OF INTRINSICALLY SAFE APPARATUS TO ASSOCIATED APPARATUS NOT SPECIALLY EXAMINED IN SUCH COMBINATION. THE CRITERIA FOR INTERCONNECTION IS THAT THE VOLTAGE (U_i OR V_{max}), THE CURRENT (I_i OR I_{max}), AND THE POWER (P_i OR P_{max}) WHICH AN INTRINSICALLY SAFE APPARATUS CAN RECEIVE AND REMAIN INTRINSICALLY SAFE CONSIDERING FAULTS, MUST BE EQUAL OR GREATER THAN VOLTAGE (U_o , V_{oc} , OR V_t), THE CURRENT (I_o , I_{sc} , OR I_t) AND THE POWER (P_o OR P_{max}) LEVELS WHICH CAN BE DELIVERED BY THE ASSOCIATED APPARATUS, CONSIDERING FAULTS AND APPLICABLE FACTORS. IN ADDITION, THE MAXIMUM UNPROTECTED CAPACITANCE (C_i) AND THE INDUCTANCE (L_i) OF EACH APPARATUS (OTHER THAN THE TERMINATION) CONNECTED TO THE FIELDBUS SEGMENT MUST BE LESS THAN OR EQUAL TO 5 nF AND 10 μ H RESPECTIVELY.

IN EACH SEGMENT ONLY ONE ACTIVE DEVICE, NORMALLY THE ASSOCIATED APPARATUS, IS ALLOWED TO PROVIDE THE NECESSARY ENERGY FOR THE FIELDBUS SYSTEM. THE VOLTAGE U_o (OR V_{oc} OR V_t) OF THE ASSOCIATED APPARATUS IS LIMITED TO 17.5VDC MAXIMUM. ALL OTHER EQUIPMENT CONNECTED TO THE BUS CABLE HAS TO BE PASSIVE, MEANING THAT THEY ARE NOT ALLOWED TO PROVIDE ENERGY TO THE SYSTEM, EXCEPT A LEAKAGE CURRENT OF 50 μ A FOR EACH CONNECTED DEVICE. SEPARATELY POWERED EQUIPMENT NEEDS GALVANIC ISOLATION TO ASSURE THAT THE INTRINSICALLY SAFE FIELDBUS CIRCUIT REMAINS PASSIVE.

THE CABLE USED TO INTERCONNECT DEVICES NEEDS TO HAVE THE PARAMETERS IN THE FOLLOWING RANGE:

Loop Resistance R_c :	15.....150 Ohm/km
Inductance per unit length L_c :	0.4.....1 mH/km
Capacitance per unit length C_c :	45.....200 nF
Length of trunk cable:	less than or equal to 1000m
Length of spur cable:	less than or equal to 60m

AT EACH END OF THE TRUNK CABLE AN APPROVED INFALLIBLE LINE TERMINATION WITH THE FOLLOWING PARAMETERS IS SUITABLE:

$$R = 90 \dots 102 \text{ Ohm} \quad C = 0 \dots 2.2 \mu\text{F}$$

ONE OF THE ALLOWED TERMINATIONS MIGHT ALREADY BE INTEGRATED IN THE ASSOCIATED APPARATUS. THE NUMBER OF PASSIVE APPARATUS CONNECTED TO THE BUS SEGMENT IS NOT LIMITED DUE TO I. S. REASONS. IF THE ABOVE RULES ARE RESPECTED, UP TO A TOTAL LENGTH OF 1000 m (SUM OF TRUNK AND ALL SPUR CABLES) OF CABLE IS PERMITTED. THE INDUCTANCE AND THE CAPACITANCE OF THE CABLE WILL NOT IMPAIR THE INTRINSIC SAFETY OF THE INSTALLATION.

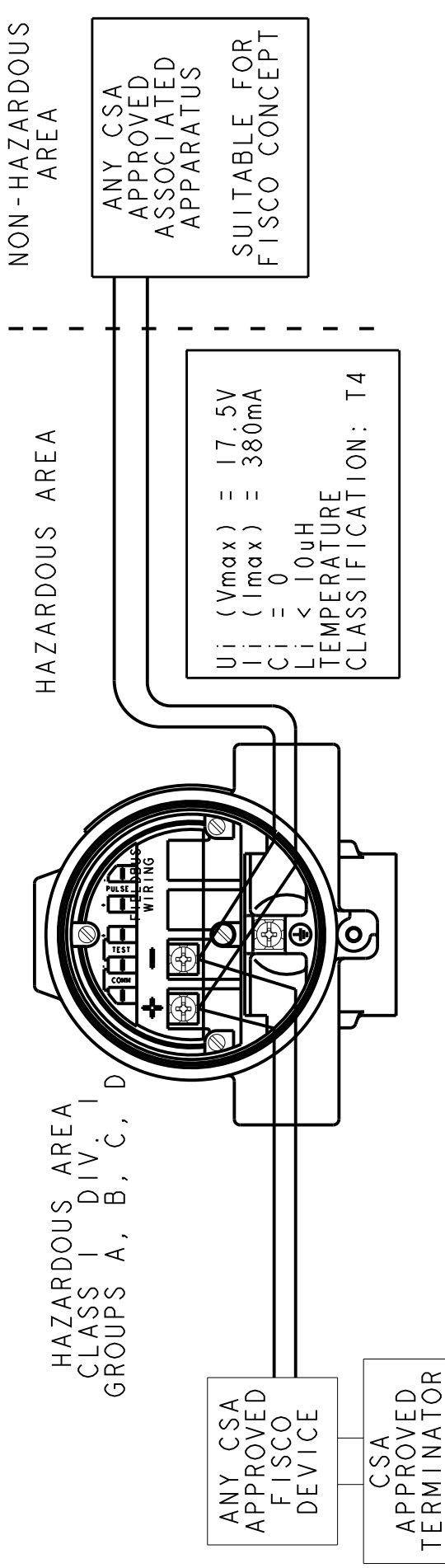

SPECIAL CONDITIONS (X-CONDITIONS) FOR CLASS / ZONE INSTALLATIONS:

1. WHEN FITTED WITH 90V TRANSIENT SUPPRESSORS, THE EQUIPMENT IS NOT CAPABLE OF PASSING THE 500V INSULATION TEST. THIS MUST BE TAKEN INTO ACCOUNT UPON INSTALLATION.
2. THE ENCLOSURE MAY BE MADE FROM ALUMINUM ALLOY AND GIVEN A PROTECTIVE POLYURETHANE PAINT FINISH; HOWEVER, CARE SHOULD BE TAKEN TO PROTECT IT FROM IMPACT OR ABRASION WHEN LOCATED IN ZONE 0. THE POLYURETHANE PAINT FINISH MAY CONSTITUTE AN ELECTROSTATIC HAZARD AND MUST ONLY BE CLEANED WITH DAMP CLOTH.
3. WHEN THE EQUIPMENT IS INSTALLED, PARTICULAR PRECAUTIONS MUST BE TAKEN TO ENSURE, TAKING INTO ACCOUNT THE EFFECT OF PROCESS FLUID TEMPERATURE, THAT THE AMBIENT TEMPERATURE OF THE ELECTRICAL HOUSING OF THE EQUIPMENT MEETS THE MARKED PROTECTION TYPE TEMPERATURE RANGE.

CONFIDENTIAL AND PROPRIETARY INFORMATION IS CONTAINED HEREIN AND MUST BE HANDLED ACCORDINGLY.

UNLESS OTHERWISE SPECIFIED DIMENSIONS IN INCHES (mm). REMOVE ALL BURRS AND SHARP EDGES.

-DEC TOLERANCES-	
.X	± .1 12.5I
.XX	± .02 10.5I
.XXX	± .010 10.25I
FRACTIONS	ANGLES
± 1/32	± 2'

EMERSON
INSTALLATION DRAWING FOR:
MODEL 88000 OR 86000 CSA I.S. INSTALLATION OR NON-INCENDIVE FIELD WIRING INSTALLATION APPROVAL FOR HART AND FIELDBUS

ROSEMOUNT

SURFACE FINISH UNLESS OTHERWISE SPECIFIED

125°

3RD ANGLE

SIZE C

SCALE -

REV AE

DRAWING NO. 08800-0112

FIELDBUS NON-INCENDIVE FNICO CONCEPT

FNICO RULES

THE FIELDBUS NON-INCENDIVE CONCEPT ALLOWS INTERCONNECTION OF NON-INCENDIVE OR INTRINSICALLY SAFE APPARATUS IN DIVISION 2 TO ASSOCIATED APPARATUS NOT SPECIALLY EXAMINED IN SUCH COMBINATION. THE CRITERIA FOR INTERCONNECTION IS THAT THE VOLTAGE (V_{max}) WHICH THE NON-INCENDIVE OR INTRINSICALLY SAFE APPARATUS CAN RECEIVE MUST BE EQUAL OR GREATER THAN THE OUTPUT VOLTAGE (V_{oc}) WHICH CAN BE DELIVERED BY THE ASSOCIATED APPARATUS.

IN ADDITION, THE MAXIMUM UNPROTECTED CAPACITANCE (C_i) AND THE INDUCTANCE (L_i) OF EACH APPARATUS (OTHER THAN THE TERMINATION) CONNECTED TO THE FIELDBUS MUST BE LESS THAN OR EQUAL TO 5 nF AND 20 μ H RESPECTIVELY.

IN EACH SEGMENT ONLY ONE ACTIVE DEVICE, NORMALLY THE ASSOCIATED APPARATUS, IS ALLOWED TO PROVIDE THE NECESSARY ENERGY FOR THE FIELDBUS SYSTEM. THE VOLTAGE (V_{oc}) OF THE ASSOCIATED APPARATUS IS LIMITED TO A RANGE OF 14V TO 17.5Vd.c.. ALL OTHER EQUIPMENT CONNECTED TO THE BUS CABLE HAS TO BE PASSIVE, MEANING THAT THEY ARE NOT ALLOWED TO PROVIDE ENERGY TO THE SYSTEM, EXCEPT A LEAKAGE CURRENT OF 50 μ A FOR EACH CONNECTED DEVICE. SEPARATELY POWERED EQUIPMENT NEEDS GALVANIC ISOLATION BETWEEN ITS OWN SOURCE OF SUPPLY AND ITS FIELDBUS CONNECTIONS.

THE CABLE USED TO INTERCONNECT DEVICES NEEDS TO HAVE THE PARAMETERS IN THE FOLLOWING RANGE:

Loop Resistance R_c :	15.....150 Ohm/km
Inductance per unit length L_c :	0.4.....1 mH/km
Capacitance per unit length C_c :	45.....200 nF/km
Length of trunk cable:	less than or equal to 1000m
Length of spur cable:	less than or equal to 60m

AT EACH END OF THE TRUNK CABLE AN APPROVED INFALLIBLE LINE TERMINATION WITH THE FOLLOWING PARAMETERS IS SUITABLE:

$$R = 90.....102 \text{ Ohm}$$

$$C = 0.....2.2\mu\text{F}$$

ONE OF THE ALLOWED TERMINATIONS MIGHT ALREADY BE INTEGRATED IN THE ASSOCIATED APPARATUS. THE NUMBER OF PASSIVE APPARATUS CONNECTED TO THE BUS SEGMENT IS NOT LIMITED DUE TO I. S. REASONS. IF THE ABOVE RULES ARE RESPECTED, UP TO A TOTAL LENGTH OF 1000 m (SUM OF TRUNK AND ALL SPUR CABLES) OF CABLE IS PERMITTED. THE INDUCTANCE AND THE CAPACITANCE OF THE CABLE WILL NOT IMPAIR THE SAFETY OF THE INSTALLATION.

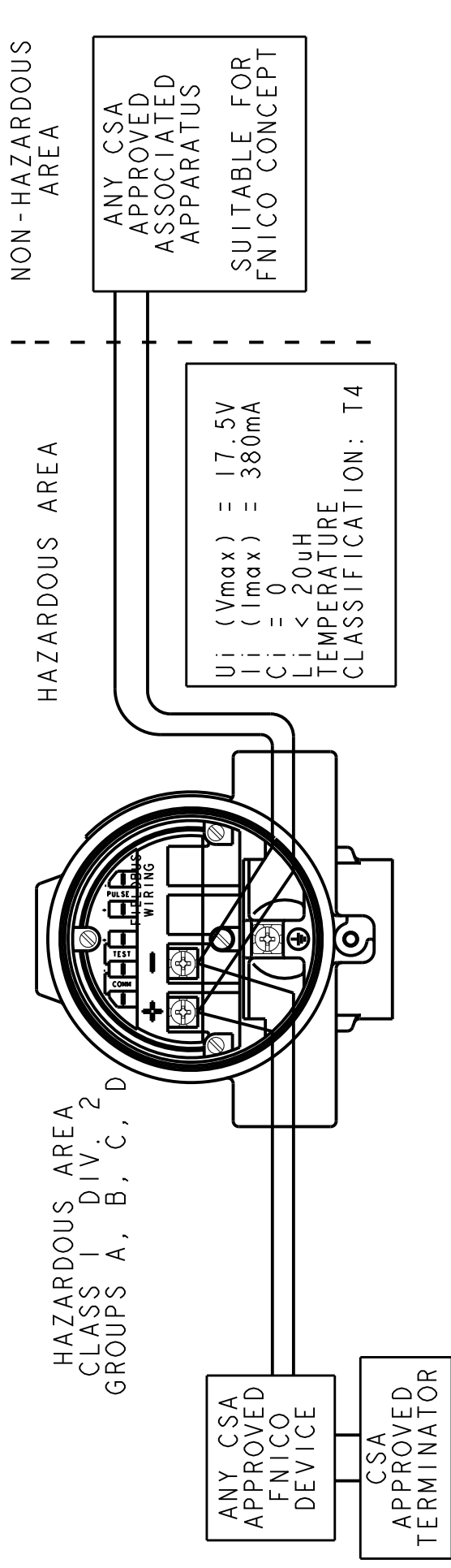

CONFIDENTIAL AND PROPRIETARY INFORMATION IS CONTAINED HEREIN AND MUST BE HANDLED ACCORDINGLY.

UNLESS OTHERWISE SPECIFIED DIMENSIONS IN INCHES (mm). REMOVE ALL BURRS AND SHARP EDGES.

-DEC TOLERANCES-
.X ± .1 12.5I
.XX ± .02 10.5I
.XXX ± .010 10.25I
FRACTIONS ANGLES
± 1/32 ± 2°

SURFACE FINISH UNLESS OTHERWISE SPECIFIED

125°

3RD ANGLE



SIZE C

SCALE -

REV AE

EMERSON ROSEMOUNT

INSTALLATION DRAWING FOR:

MODEL 88000 OR 86000 CSA T.S. INSTALLATION OR NON-INCENDIVE FIELD WIRING INSTALLATION APPROVAL FOR HART AND FIELDBUS

DR. N. BOND 6-25-15 DRAWING NO. 08800-0112

APP'D. PRODUCT CODE SHEET 6 OF 8

08800-0112

DRAWING NO.

1	2	3	4	5	6	7	8	9	10	11	12
A	B	C	D	E	F	G	H	08800-0112			
REPLACEMENT OF FM MARKED 88000 TRANSMITTERS WITH EQUIVALENT CSA MODEL CODE											
ORIGINAL MODEL			CSA REPLACEMENT TRANSMITTER EQUIVALENCY								
APPROVAL CODE	FM RATING	APPROVAL CODE	CSA RATING								
I5	INTRINSICALLY SAFE FOR CLASS I, II, III DIVISION 1 GROUPS A,B,C,D,E,F,G. NONINCENDIVE FOR CLASS I, DIVISION 2, GROUPS A,B,C,D	I5, I6, K6 OR KB	INTRINSICALLY SAFE FOR CLASS I, II, III DIVISION 1 GROUPS A,B,C,D,E,F,G. NONINCENDIVE FOR CLASS I, DIVISION 2, GROUPS A,B,C,D								
E5	EXPLOSION PROOF FOR CLASS I, DIV 1, GROUPS B, C, D DUST-IGNITION PROOF FOR Class II, III, Div 1, GROUPS E,F, G	E5, E6, K6 OR KB	EXPLOSION PROOF FOR CLASS I, DIV 1, GROUPS B, C, D DUST-IGNITION PROOF FOR Class II, III, Div 1, GROUPS E,F, G								
IE	FISCO INTRINSICALLY SAFE	IE OR IF	FISCO INTRINSICALLY SAFE								
K5	INTRINSICALLY SAFE FOR CLASS I, II, III DIVISION 1 GROUPS A,B,C,D,E,F,G. NONINCENDIVE FOR CLASS I, DIVISION 2, GROUPS A,B,C,D EXPLOSION PROOF FOR CLASS I, DIV 1, GROUPS B, C, D DUST-IGNITION PROOF FOR Class II, III, Div 1, GROUPS E,F, G	K5, K6 OR KB	INTRINSICALLY SAFE FOR CLASS I, II, III DIVISION 1 GROUPS A,B,C,D,E,F,G. NONINCENDIVE FOR CLASS I, DIVISION 2, GROUPS A,B,C,D EXPLOSION PROOF FOR CLASS I, DIV 1, GROUPS B, C, D DUST-IGNITION PROOF FOR Class II, III, Div 1, GROUPS E,F, G								
KB	INTRINSICALLY SAFE FOR CLASS I, II, III DIVISION 1 GROUPS A,B,C,D,E,F,G. NONINCENDIVE FOR CLASS I, DIVISION 2, GROUPS A,B,C,D EXPLOSION PROOF FOR CLASS I, DIV 1, GROUPS B, C, D DUST-IGNITION PROOF FOR Class II, III, Div 1, GROUPS E,F, G	K6 OR KB	INTRINSICALLY SAFE FOR CLASS I, II, III DIVISION 1 GROUPS A,B,C,D,E,F,G. NONINCENDIVE FOR CLASS I, DIVISION 2, GROUPS A,B,C,D EXPLOSION PROOF FOR CLASS I, DIV 1, GROUPS B, C, D DUST-IGNITION PROOF FOR Class II, III, Div 1, GROUPS E,F, G								
Blank	Ordinary Locations	Blank	Ordinary Locations								

CONFIDENTIAL AND PROPRIETARY INFORMATION IS CONTAINED HEREIN AND MUST BE HANDLED ACCORDINGLY.

UNLESS OTHERWISE SPECIFIED DIMENSIONS IN INCHES (mm). REMOVE ALL BURRS AND SHARP EDGES.

-DEC TOLERANCES-
.X ± .1 12.5I
.XX ± .02 10.5I
.XXX ± .010 10.25I
FRACTIONS ANGLES
± 1/32 ± 2'

EMERSON
ROSEMOUNT

TITLE: INSTALLATION DRAWING FOR: MODEL 88000 OR 86000 CSA I.S. INSTALLATION OR NON-INCENDIVE FIELD WIRING INSTALLATION APPROVAL FOR HART AND FIELDBUS

DR. N. BOND DRAWING NO. 6-25-15
APP'D. 08800-0112

DO NOT SCALE PRINT CAD MAINTAINED. (PRO/E) PRODUCT CODE SHEET 7 OF 8

Ex d - FLAMEPROOF INSTALLATIONS FOR CLASS I, ZONE 1

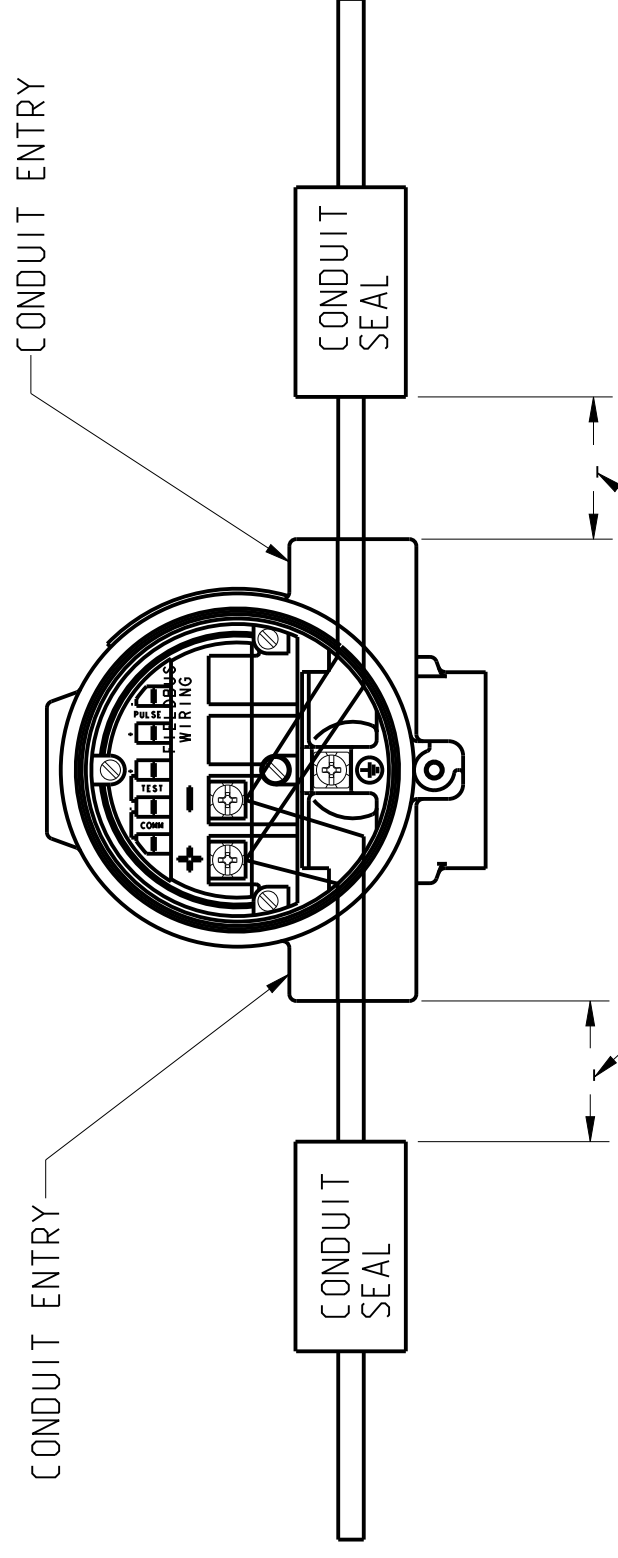

FOR Ex d INSTALLATIONS ONLY:
⚠ WARNING:
 A SEAL SHALL BE INSTALLED WITHIN 50mm OF THE ENCLOSURE
 UN SCÉLÈMENT DOIT ÊTRE INSTALLÉ À MOINS DE 50mm DUBOITIER

- SPECIAL CONDITIONS (X-CONDITIONS) FOR CLASS / ZONE INSTALLATIONS:
1. FOR INFORMATION REGARDING THE DIMENSIONS OF THE FLAMEPROOF JOINTS THE MANUFACTURER SHALL BE CONTACTED.
 2. THE FLOWMETER IS PROVIDED WITH SPECIAL FASTENERS OF PROPERTY CLASS A2-70 OR A4-70.
 3. UNITS MARKED WITH "WARNING: ELECTROSTATIC CHARGING HAZARD" MAY USE NON-CONDUCTIVE PAINT THICKER THAN 0.2mm. PRECAUTIONS SHALL BE TAKEN TO AVOID IGNITION DUE TO ELECTROSTATIC CHARGE ON THE ENCLOSURE.
 4. WHEN THE EQUIPMENT IS INSTALLED, PRECAUTIONS SHALL BE TAKEN TO ENSURE THE AMBIENT TEMPERATURE OF THE TRANSMITTER LIES BETWEEN -50°C TO +70°C, TAKING INTO ACCOUNT PROCESS FLUID EFFECTS. IF THE AMBIENT TEMPERATURE IS OUTSIDE THIS RANGE REMOTE TRANSMITTERS SHALL BE USED.

CONFIDENTIAL AND PROPRIETARY INFORMATION IS CONTAINED HEREIN AND MUST BE HANDLED ACCORDINGLY.		SURFACE FINISH UNLESS OTHERWISE SPECIFIED		125°	3RD ANGLE	SIZE	SCALE	REV
UNLESS OTHERWISE SPECIFIED DIMENSIONS IN INCHES (mm). REMOVE ALL BURRS AND SHARP EDGES.		EMERSON				C	-	AE
-DEC TOLERANCES- .X ± .1 12.51 .XX ± .02 10.51 .XXX ± .010 10.251 FRACTIONS ± 1/32 ANGLES ± 2'		TITLE		INSTALLATION DRAWING FOR:		ROSEMOUNT		
		MODEL 88000 OR 86000 CSA T.S. INSTALLATION OR NON-INCENDIVE FIELD WIRING INSTALLATION APPROVAL FOR HART AND FIELDBUS		DR.		6-25-15		08800-0112
		APP'D.		DRAWING NO.		08800-0112		
DO NOT SCALE PRINT		CAD MAINTAINED		PRODUCT CODE		DOC TYPE		SHEET 8 OF 8

08800-0112

This page is intentionally blank

This page is intentionally blank



00825-VA00-0001, Rev. AA
May 2019

Emerson Automation Solutions USA

7070 Winchester Circle
Boulder, Colorado USA 80301
T +1 303-527-5200
T +1 800-522-6277
F +1 303-530-8459
www.emerson.com

Emerson Automation Solutions Asia

1 Pandan Crescent
Singapore 128461
Republic of Singapore
T +65 6363-7766
F +65 6770-8003

Emerson Automation Solutions Europe

Neonstraat 1
6718 WX Ede
The Netherlands
T +31 (0) 70 413 6666
F +31 (0) 318 495 556
www.micromotion.nl

Emerson Automation Solutions United Kingdom

Emerson Process Management Limited
Horsfield Way
Bredbury Industrial Estate
Stockport SK6 2SU U.K.
T +44 0870 240 1978
F +44 0800 966 181

©2019 Rosemount, Inc. All rights reserved.

The Emerson logo is a trademark and service mark of Emerson Electric Co. Rosemount, 8600, 8700, 8800 marks are marks of one of the Emerson Automation Solutions family of companies. All other marks are property of their respective owners.