

WE-350 Series ¼ Turn Electric Actuator

Operation and Installation Manual

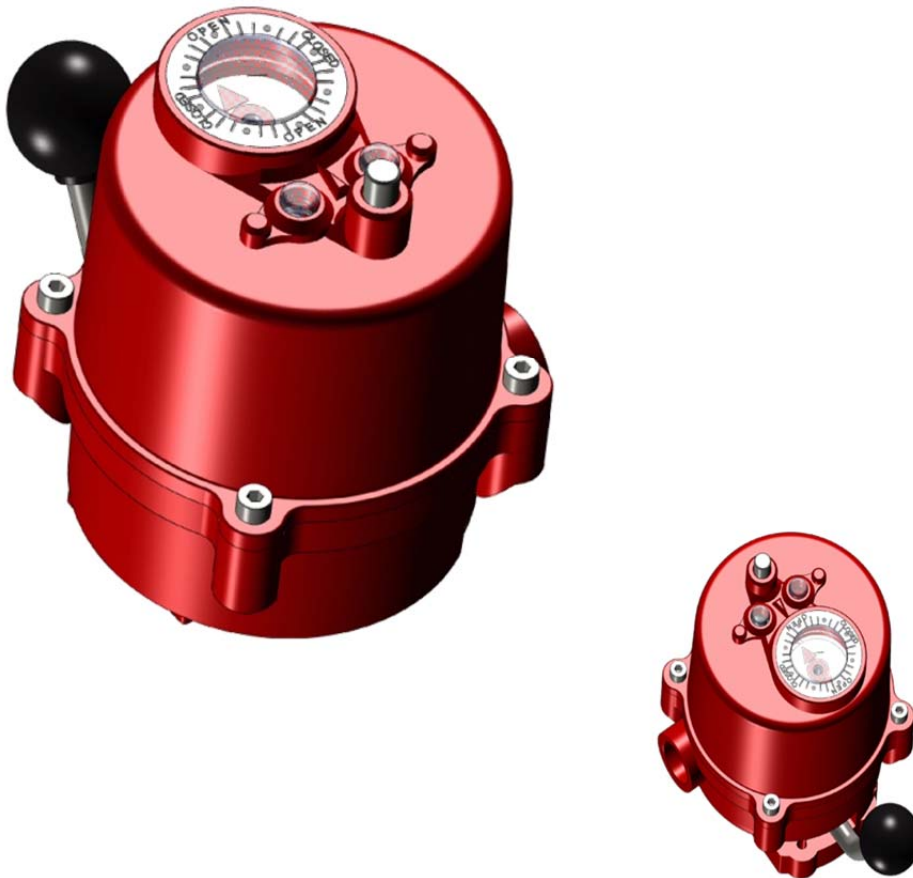



Division of A-T Controls Inc.
9955 International Blvd
Cincinnati, Ohio 45246
(513) 247-5465 Fax (513)247-5462

INSTALLATION & MAINTENANCE MANUAL

WE-350 Series Electric Actuator
On/Off Control

Table of Contents

- 1.0 General**
 - 1.1 Pre-Installation Inspection**
 - 1.2 Storage**
 - 1.3 Features & General Information**
 - 1.3.1 Duty Cycle
 - 1.3.2 Heater
 - 1.3.3 Manual Hand lever
 - 1.3.4 Lubrication
 - 1.4 Parts**
 - 1.4.1 External Parts
 - 1.4.2 Internal Parts
- 2.0 Installation Instruction**
 - 2.1 Actuator Mounting
- 3.0 Limit Switch Setting**
- 4.0 Manual Override**
- 5.0 Electrical Connection**
- 6.0 Mechanical Position Indicator**
- 7.0 Wiring Diagram**
- 8.0 Maintenance**
- 9.0 Trouble Shooting**
- 10.0 Standard Specifications**
- 11.0 Contact Information**



Division of A-T Controls Inc.
 9955 International Blvd
 Cincinnati, Ohio 45246
 (513) 247-5465 Fax (513)247-5462

**INSTALLATION & MAINTENANCE
 MANUAL**

**WE-350 Series Electric Actuator
 On/Off Control**

1.0 General

WE-350 Series electric actuators are designed to provide reliable and efficient operation of small size (1" and less) 90° quarter turn ball valves and dampers.

Warning: Use caution when working in, with, or around valves and actuators. High pressures, forces, voltages and flammable media can be present.

Warning: Failure to follow instructions for proper electrical wiring, storage, set-up and maintenance may cause serious injury, damage equipment, or void warranty.

1.1 Pre-Installation Inspection

Verify the actuator nameplate to ensure correct model number, torque, operating speed, voltage and enclosure type before installation or use.

It is important to verify that the output torque of the actuator is appropriate for the torque requirements of the valve and that the actuator duty cycle is appropriate for the intended application.

1.2 Storage

Actuators must be stored in a clean, cool and dry area. The unit shall be stored off the floor with the cover installed. If the actuator is mechanically installed but waiting for electrical connections, please ensure suitably rated cable glands or cable entry blanking plugs are fitted, sealing the conduit openings.

1.3 Features

1.3.1 Duty Cycle

Duty cycle rated IEC34-1 S4 (50%) / S2 30 min
 Exceeding the actuator's rated duty cycle may cause thermal overload.

**NOTE: Type of duty according to VDE 0530/IEC60034-1

| Short – time duty S2 | Intermittent duty S4 |
|--|--|
| The operation time at a constant load is short, so that thermal equilibrium is not reached. The pause is long enough for the machine to cool down to ambient temperature. The duration of the short –time operation is limited to 15min (10min, 30min) | The duty is a sequence of identical cycles which consist of starting time, operation time with constant load and rest period. The rest period allows the machine to cool down so that thermal equilibrium is not reached. The relative on-time at S4-25% or S4-50% is limited to 25% and 50% respectively. |

1.3.2 Heater

Condensation in the actuator is possible due to wide fluctuation of the ambient temperature. The control unit's heater prevents this.

1.3.3 Manual Hand lever

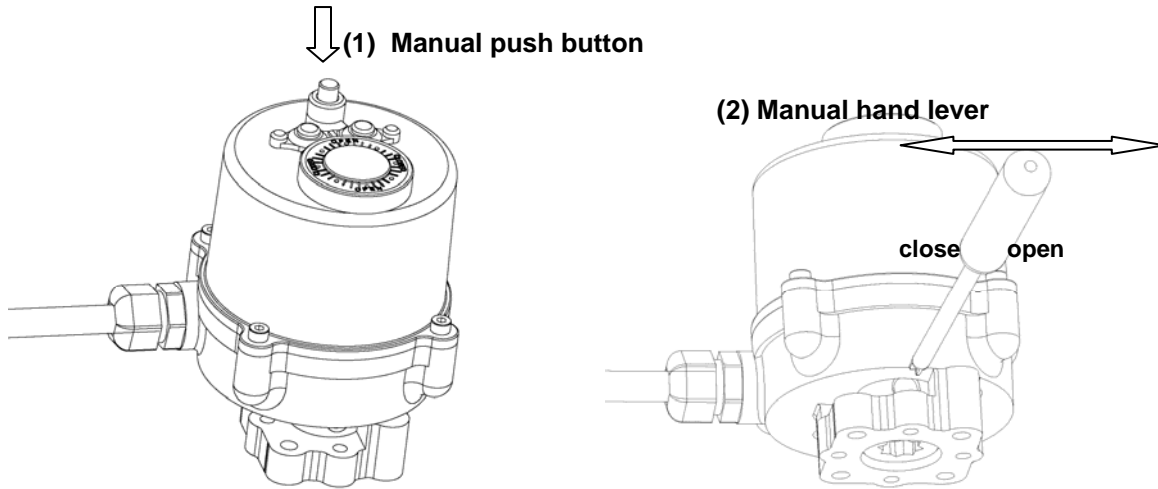

1.3.4 Lubrication

The WE-350 series actuators are totally enclosed units with permanently lubricated gear trains (Moly EP Grease). Once installed lubrication should not be required. However, periodic preventative maintenance will extend the operating life of the actuator.

1.4 Parts

1.4.1 External Parts for Standard Models

| External Parts | |
|----------------|--|
| 1 | Top Cover |
| 2 | Body |
| 3 | Cable entry (PG 11)x1 & Wire (47-1/4") |
| 4 | Drive shaft (star11mm) |
| 5 | Mounting base (F03,F04,F05) |
| 6 | Manual lever hole |
| 7 | Name plate |
| 8 | Cover bolt (captive design) |
| 9 | Indicator |
| 10 | Full Close LED lamp (Green) |
| 11 | Manual push button |
| 12 | Full Open LED lamp (Red) |

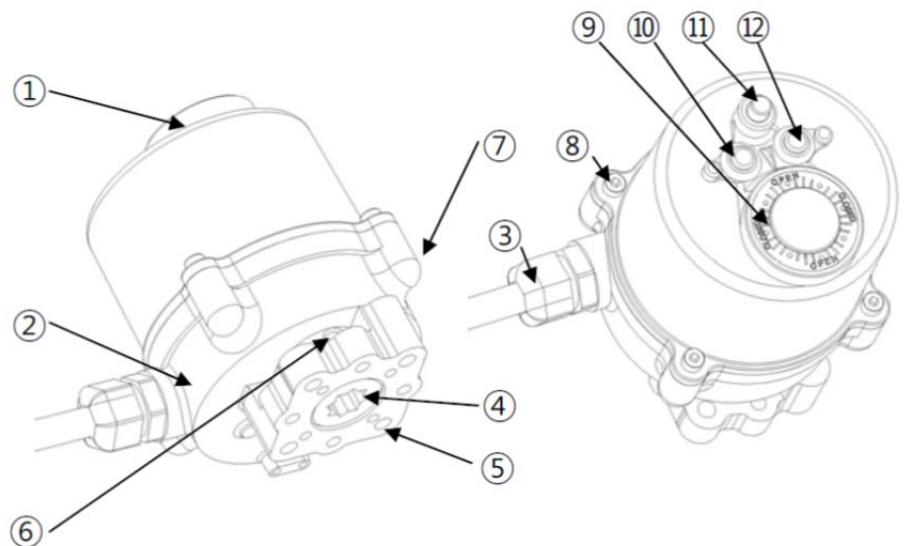

1.4.2 Internal Parts for Standard Models

| Internal Parts | |
|----------------|-----------------------------------|
| 1 | Manual push shaft |
| 2 | Indicator |
| 3 | On/off PCB & Heater |
| 4 | Additional Close limit switch set |
| 5 | Additional Open limit switch set |
| 6 | Close limit switch set |
| 7 | Open limit switch set |
| 8 | Full Close LED lamp (green) |
| 9 | Full Open LED lamp (red) |

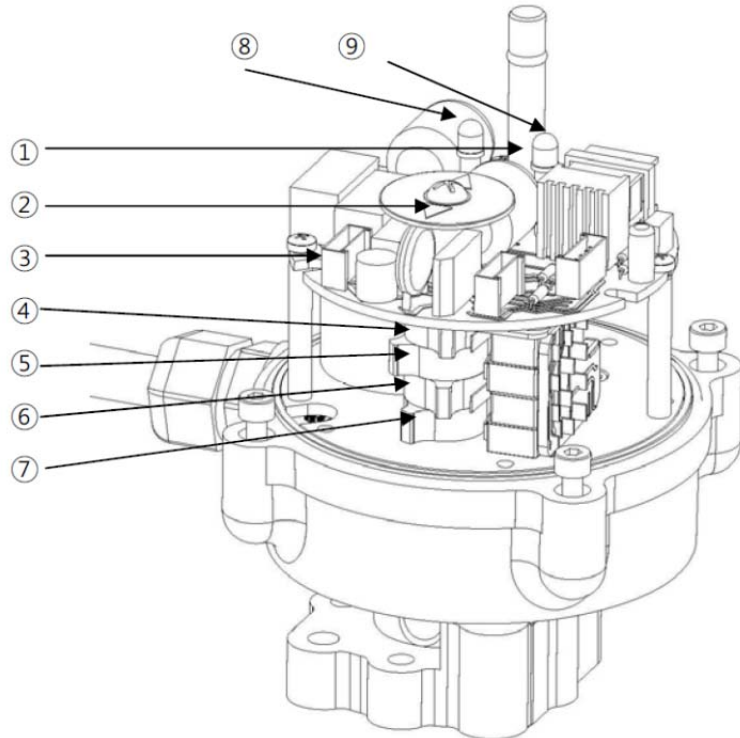

2.0 Installation Instruction

2.1 Actuator Mounting

Mounting is most easily done with the valve shaft pointing vertically upward, but the actuator may be mounted in any position.

WE-350 Series actuators are supplied with a female drive output. ISO5211 bolt patterns are provided for the actuator mounting.

It is mandatory that the actuator be firmly secured to a sturdy mounting bracket or directly mounted to the valves ISO mounting pad. High tensile bolts or studs with spring locking washers must be used.

The valve output stem must be in line with the actuator output drive to avoid side loading of the stem.

To prevent backlash, no flexibility in the mounting bracket arrangement should be present.

Caution ;

- ✓ **Do not attempt to work on your HKC actuator without first shutting off incoming power.**
- ✓ **Do not attach ropes or hooks to the hand wheel for the purpose of lifting by hoist.**

Actuator Mounting Details

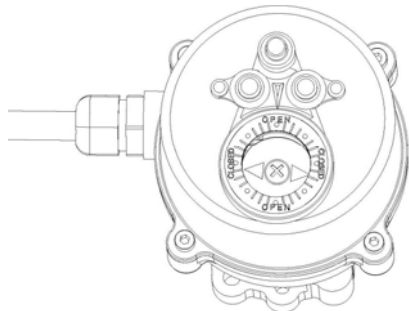

*Direct mounting
(ISO Standard)

ACTUATOR: CLOSED

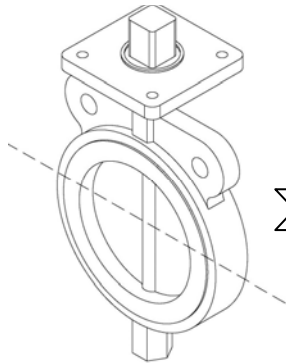

VALVE: CLOSED

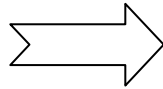

*Bracket mounting

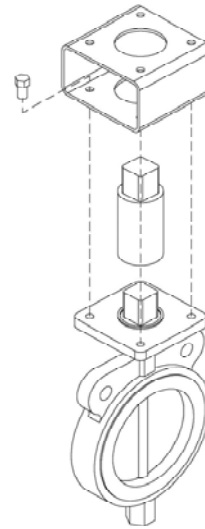

* Make sure that both valve and actuator are closed.

Actuator mounting base: F03/F05 and F04

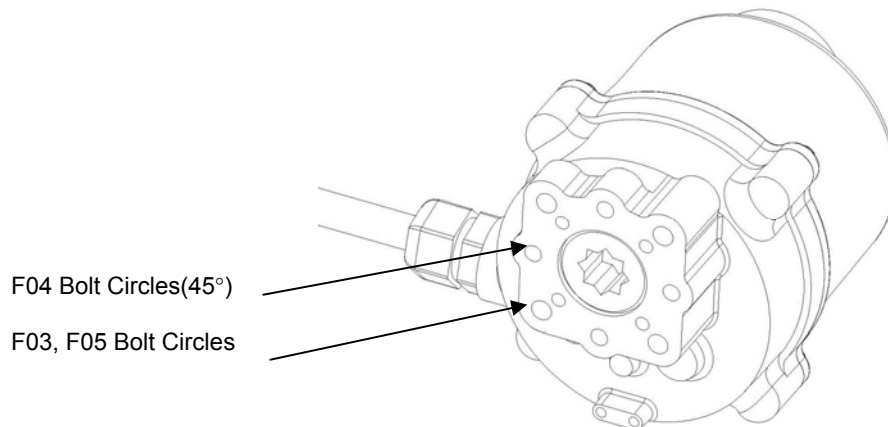

Star Adapter
11mm→9mm



Danger: HAZARDOUS VOLTAGE. Make sure all power is disconnected before mounting

3.0 Limit Switch Setting

- Operate the actuator manually to the closed position.
- Using an allen key, loosen the cam adjustment screw in the CLOSE limit switch cam.
- Rotate the CLS cam CW towards the limit switch lever until the switch 'clicks'. Tighten screw with allen key.
- Operate the actuator manually to the open position.
- Using an allen key, loosen the cam adjustment screw in the OPEN limit switch cam.
- Rotate the OLS cam CCW towards the limit switch lever until the switch 'clicks'. Tighten with allen key.



Danger: HAZARDOUS VOLTAGE. Make sure all power is disconnected before setting

4.0 Manual Override

The WE-350 actuators are supplied with a 'spanner type' manual override. This is located on the bottom of the unit and can be operated with an adjustable wrench.

Please Note:

Because the actuator does not have mechanical limit stops, be careful not to rotate past the valves full open or closed position.

5.0 Electrical Connection

- Manually move valve to mid-position. This will allow sufficient time to stop actuator in case of improper hook-up or reversed power phases.
- Identify means of removing power during hookup.
- Be sure no erroneous remote control signals can be received causing actuator to energize.
- Electrically operate the valve in the open direction. If the valve closes, actuator must be stopped and the power leads reversed to correct voltage phasing or improper field wiring.

Please Note:

Improper power voltage phasing eliminates protection of the position limit switch, risking valve damage.

6.0 Mechanical Position Indicator

- Manually rotate actuator to fully closed position.
- Remove actuator cover.
- Loosen the indicator screw.
- Rotate indicator to the correct orientation.
- Tighten indicator screw, replace cover and check alignment.

7.0 Wiring Diagram

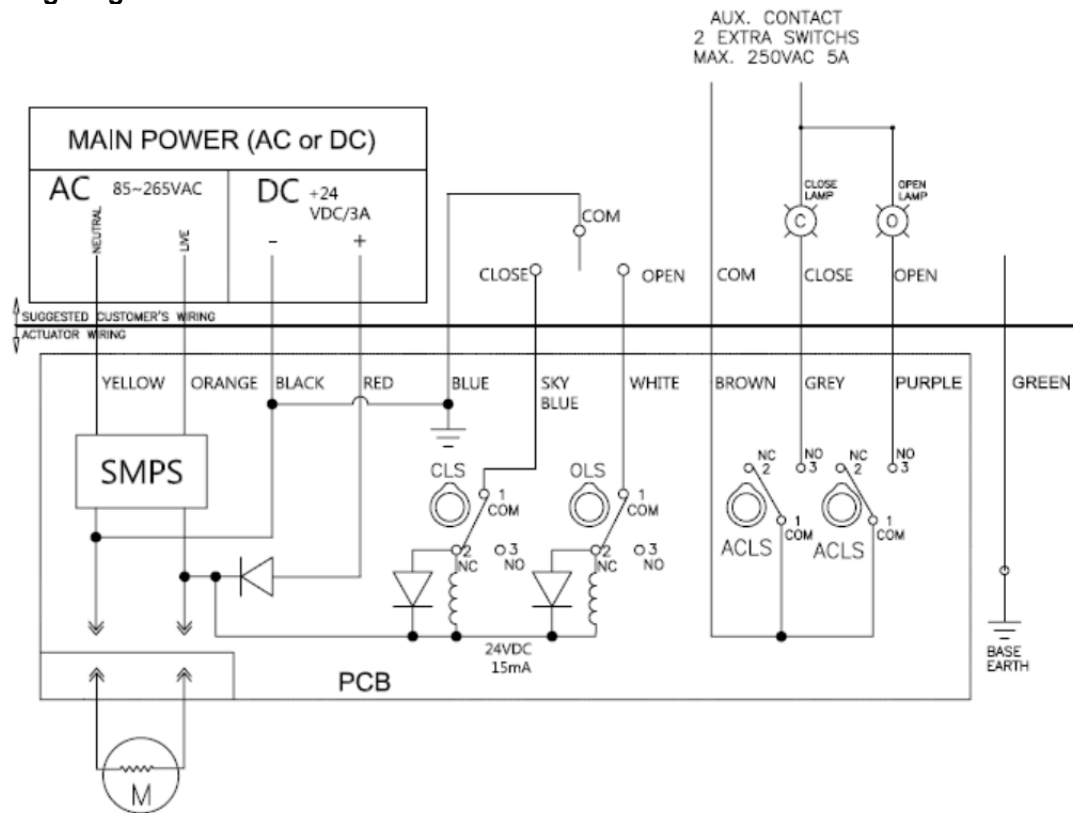

Danger: HAZARDOUS VOLTAGE. No electrical power should be connected until all wiring and limit switch adjustments are completed. Once power is supplied to unit, exercise caution if cover is not installed.

8.0 Maintenance

- At least once a year your WE-350 Series Actuator should be thoroughly checked.
- Disconnect all power to actuator.
- Check that all external bolting and mounting to the valve is secure and aligned.
- Check to see that conduit connections are installed properly and are dry.
- Open Electrical Enclosure.
- Visually inspect for cleanliness and any electrical or mechanical damage. Inspect for excess moisture and condensation inside the electrical enclosure.
- Confirm that wiring is insulated, connected and terminated properly.
- Check enclosure O-ring seals and verify that the O-ring is not pinched between the flanges.
- Visually inspect during open/close cycle.

9.0 Trouble Shooting

The following instructions are offered for the most common difficulties encountered during installation and set-up.

| SYMPTON | PROBABLE CAUSE | CORRECTIVE ACTION |
|--|---|---|
| Motor will not run. | Open in control circuit | Refer to appropriate wiring diagram and check for continuity. |
| No power available to actuator. | Tripped circuit breaker | Reset breaker and check for correct rating. Refer to catalogue data. |
| Manual Override is hard to turn. | Incorrectly sized actuator Jammed valve Damaged or bent valve stem Valve gland packing too tight | Refer to catalogue data and compare valve torque requirements with actuator (torque) output. Check for obstacles in the pipeline. Check for mechanical damage. |
| Valve only opens or closes partially with motor. | Limit switch incorrectly set Over torque: Incorrectly sized actuator Jammed valve Damaged or bent valve stem | Check setting and reset if necessary. Check to see if motor runs when disconnected from the valve. If so, refer to catalogue data and compare valve torque requirements with actuator (torque) output. Check for obstacles in the pipeline. Check for mechanical damage |
| Manual Override does not operate valve. | Damaged manual override mechanism Stripped gearing Broken valve stem | Check for mechanical damage, replace parts as necessary. |
| Motor runs but does not operate valve. | Stripped gearing Damaged actuator / valve linkage. | Check for mechanical damage, replace parts as necessary. |

Actuator does not respond

- Verify the line voltage to the actuator
- Check that the voltage matches the rating on the actuator nameplate
- Check internal wiring against actuator wiring diagram
- Check limit switch cams

Actuator is receiving power but does not operate

- Verify the line voltage to the actuator
- Check actuator force to see if it's greater than the valve force
- Check limit switches and cams
- Check that the force switches have not tripped
- Check mechanical travel stop adjustment
- Verify the actuator against valve rotation (standard units are counter-clockwise open)
- Check internal wiring
- Check for corrosion and condensation
- Verify coupler/bracket are correctly installed and is not causing binding

Actuator runs erratically

- Check ambient temperature
- Verify that the duty cycle has not been exceeded
- Check the position of manual override lever



Division of A-T Controls Inc.
9955 International Blvd
Cincinnati, Ohio 45246
(513) 247-5465 Fax (513)247-5462

INSTALLATION & MAINTENANCE MANUAL

WE-350 Series Electric Actuator
On/Off Control

10.0 Standard Specifications

| | |
|--------------------------|---|
| Enclosure Rating | Weatherproof IP67, NEMA 4 & 6 |
| Enclosure | High-grade aluminum alloy, hard anodized |
| Power Supply | 110/220VAC 1 PH 50/60Hz, 24VDC |
| Duty Cycle Motor | S4 50% / S2 30 min (IEC 60034) |
| Motor | DC Motor |
| Limit Switches | 2 x open/close SPDT, 250VAC 5A rating |
| Auxiliary Limit Switches | 2 x open/close SPDT, 250VAC 5A rating |
| Indicator | Continuous position indicator & Open/Close LED lamp |
| Manual Override | Manual push button & manual lever; 'Spanner type' manual override |
| Space Heater | 0.5W |
| Conduit Entries | PG 11x1 and Long (47 1/4") Wire Type |
| Lubrication | Grease Moly EP |
| Ambient Temperature | -4 °F to +158 °F |
| External Coating | Dry powder polyester |

11.0 Contact Information

For technical support, please contact the Triac office.

A-T Controls product, when properly selected, is designed to perform its intended function safely during its useful life. However, the purchaser or user of A-T Controls products should be aware that A-T Controls products might be used in numerous applications under a wide variety of industrial service conditions. Although A-T Controls can provide general guidelines, it cannot provide specific data and warnings for all possible applications. The purchaser / user must therefore assume the ultimate responsibility for the proper sizing and selection, installation, operation, and maintenance of A-T Controls products. The user should read and understand the installation operation maintenance (IOM) instructions included with the product, and train its employees and contractors in the safe use of A-T Controls products in connection with the specific application.

While the information and specifications contained in this literature are believed to be accurate, they are supplied for informative purposes only. Because A-T Controls is continually improving and upgrading its product design, the specifications, dimensions and information contained in this literature are subject to change without notice. Should any question arise concerning these specifications, the purchaser/user should contact A-T Controls.

For product specifications go to <http://download.a-tcontrols.com/>

A-T Controls, Inc. • 9955 International Boulevard, Cincinnati, OH 45246 • Phone: (513) 530-5175 • Fax: (513) 247-5462 • www.a-tcontrols.com