

Rosemount™ 3900/3900VP

General Purpose pH/ORP Sensor

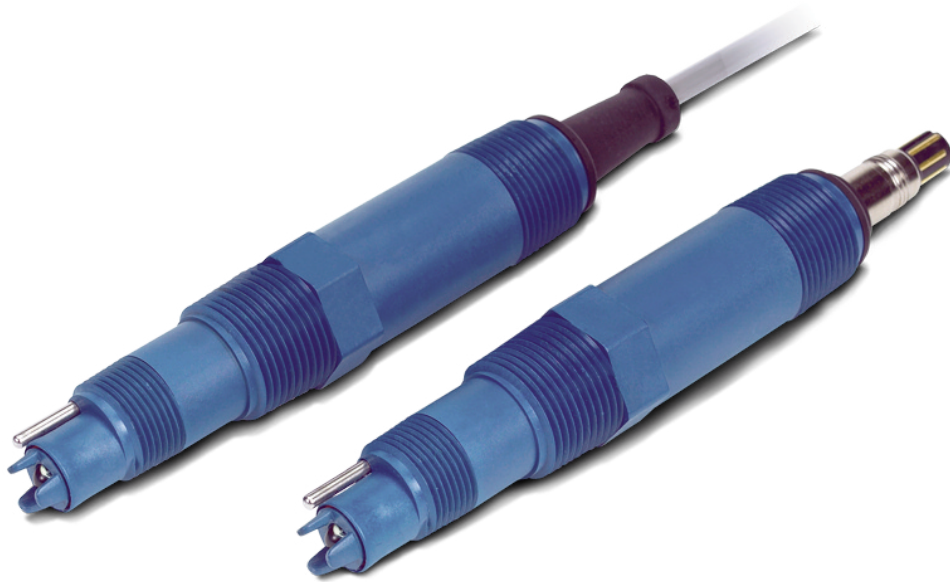

Essential Instructions

Read this page before proceeding!

Emerson designs, manufactures, and tests its products to meet many national and international standards. Because these sensors are sophisticated technical products, you **MUST** properly install, use, and maintain them to ensure they continue to operate within their normal specifications. The following instructions **MUST** be adhered to and integrated into your safety program when installing, using, and maintaining Rosemount Analytical products. Failure to follow the proper instructions may cause any one of the following situations to occur: loss of life; personal injury; property damage; damage to this sensor; and warranty invalidation.

- Read all instructions prior to installing, operating, and servicing the product.
- If you do not understand any of the instructions, contact your Emerson representative for clarification.
- Follow all warnings, cautions, and instructions marked on and supplied with the product.
- Inform and educate your personnel in the proper installation, operation, and maintenance of the product.
- Install your equipment as specified in the Installation Instructions of the appropriate Instruction Manual and per applicable local and national codes. Connect all products to the proper electrical and pressure sources.
- To ensure proper performance, use qualified personnel to install, operate, update, program, and maintain the product.
- When replacement parts are required, ensure that qualified people use replacement parts specified by Emerson. Unauthorized parts and procedures can affect the product's performance, place the safe operation of your process at risk, and **VOID YOUR WARRANTY**. Third-party substitutions may result in fire, electrical hazards, or improper operation.
- Ensure that all equipment doors are closed and protective covers are in place, except when maintenance is being performed by qualified persons, to prevent electrical shock and personal injury.

The information contained in this document is subject to change without notice.

CAUTION

SPECIAL CONDITIONS FOR SAFE USE

1. All pH/ORP sensors have a plastic enclosure which must only be cleaned with a damp cloth to avoid the danger due to a build up of an electrostatic charge.
2. All pH/ORP sensor models are intended to be in contact with the process fluid and may not meet the 500V r.m.s. a.c. test to earth.

This must be taken into consideration at installation.

CAUTION

SENSOR/PROCESS APPLICATION COMPATIBILITY

The wetted sensor materials may not be compatible with process composition and operating conditions. Application compatibility is entirely the responsibility of the user.

WARNING

Before removing the sensor, be absolutely certain that the process pressure is reduced to 0 psig and the process temperature is lowered to a safe level!

CAUTION

The solution used during calibration is an acid and should be handled with care. Follow the directions of the acid manufacturer. Wear the proper protective equipment. Do not let the solution come in contact with skin or clothing. If contact with skin is made, immediately rinse with clean water.

About This Document

This manual contains instructions for installation and operation of the Rosemount 3900/3900VP pH/ORP sensors. The following list provides the revision history for all changes of this document.

Rev. Level	Date	Notes
F	08/2016	Updated information with new Emerson Style Guidelines, Added Ordering Information, Added Accessories Information. Added Hazardous Location Certifications. Added EC Declaration of Conformity.
G	04/2017	Updated Wiring Diagrams and Ordering Information.

Contents

Section 1: Specifications

1.1 Specifications	1
1.2 Product Certifications	2
1.3 Ordering Information.....	3

Section 2: Installation

2.1 Storage	5
2.2 Electrode Preparation	5
2.3 Sensor Installation	5

Section 3: Calibration and Maintenance

3.1 pH Two Point Buffer Calibration	13
3.2 Recommended pH Sensor Standardization	13
3.3 pH Electrode Maintenance	13
3.4 ORP Calibration	14
3.5 ORP Electrode Maintenance	14

Section 4: Accessories

15

EC Declaration of Conformity

17

FM Installation

19

Section 1: Specifications

1.1 Specifications

Measurements and Ranges: pH : 0-14 / ORP: -1500 to +1500 mV

Percent Linearity Over pH Range:

Range	Linearity
0-7	97%
1-7	98%
4-7	98%
7-10	99%
7-12	97%
7-13	96%
7-14	95%

Materials of construction:

Sensor Body: Ryton -- polyphenylene sulfide (PPS)

O-ring: EPDM

pH Electrode: Glass

ORP Electrode: Glass, platinum

Solution Ground: Stainless Steel

Reference Junction: PTFE (Teflon)

Maximum Pressure: 790 kPa [abs] (100 psig) at 212 °F (100 °C)

CRN rating: 60 psig up to 212 °F (100 °C).

Operating Temperature: 14 °F to 212 °F (-10 °C to 100 °C)

Automatic temperature compensation 14 °F to 212 °F (-10 °C to 100 °C)

Conductivity: Responds to changes in pH at a minimum conductivity of 0.1 μS/cm when used with the low flow cell panel. The sample flow rate must be controlled to 2 gph (7.6L/hr).

Process Connections:

Front facing: 3/4 inch and 1 inch MNPT

Rear facing: 1 inch MNPT

Weight/Shipping Weight: 1 lb./2 lb. (0.45 kg/0.9 kg)

Integral Cable: 32 ft (10m) cable with integral preamp; 15 ft (4.7m) cable without preamp

VP8 Cable: Use 24281-XX, 2.5 ft (0.8m) to 100 ft (31m) (see accessories)

NOTICE

The Rosemount 3900/3900VP Sensor responds to changes in pH at a minimum conductivity of 0.1 μS/cm in deionized water. Sample flow rate must be controlled to 2 gph (7.6L/hr). The offset is approximately -0.2 pH after 3 months at ambient temperature.

1.2 Product Certifications

IECEX

3900/3900VP without preamp (pH and ORP) – Ex ia IIC T4 Ga (-20 °C ≤ Ta ≤ +60 °C)

3900/3900VP with SMART preamp (pH only) – Ex ia IIC T4 Ga (-20 °C ≤ Ta ≤ +60 °C)

Per standards IEC60079-0 : 2011, IEC 60079-11 : 2011

ATEX

3900/3900VP without preamp (pH and ORP) – II 1 G Ex ia IIC T4 Ga (-20 °C ≤ Ta ≤ +60 °C)

3900/3900VP with SMART preamp (pH only) – II 1 G Ex ia IIC T4 Ga (-20 °C ≤ Ta ≤ +60 °C)

Per standards EN 60079-0: 2012+A11:2013, EN 60079-11:2012

FM

3900/3900VP with SMART preamp (pH only), with standard preamp (ORP only), and without preamp (pH and ORP):

Intrinsically Safe for use in Class I, II, and III, Division 1, Groups A, B, C, D, E, F, and G; Temperature Class T6 Ta = -20 °C to +60 °C

Intrinsically Safe for use in Class I, Zone 0, AEx ia IIC T6 Ta = -20 °C to +600 °C

Nonincendive for use in Class I, Division 2, Groups A, B, C, and D; Temperature Class T6 Ta = -20 °C to +60 °C

Suitable for use in Class II and III, Division 2, Groups E, F, and G; Temperature Class T6 Ta = -20 °C to +60 °C Hazardous (Classified) Locations

IS/I,II,III/1/ABCDEF/T6 Ta = 60 °C - 1400332; Entity; I/O/AEx ia IIC/T6 Ta = 60 °C - 1400332; Entity;

NI/I/2/ABCD/T6 Ta = 60 °C; S/II,III/2/EFG/T6 Ta = 60 °C

Per standards 3600:1998, 3610:2010, 3611:2004, 3810:2005

CSA

3900/3900VP with SMART preamp (pH only) – Intrinsically Safe:

Class I, Division 1, Groups ABCD; Class II, Division 1, Groups EFG; Class III; Class I, Division 2, Groups ABCD; Ambient temperature rating -20 °C to +60 °C; Ex ia IIC; T6

3900/3900VP without preamp (pH and ORP) – Intrinsically Safe and Non-Incendive:

Class I, Division 1, Groups ABCD; Class II, Division 1, Groups EFG; Class III; Class I, Division 2, Groups ABCD; Ex ia IIC; T6; Ambient temperature rating -20 °C to +60 °C: (Simple Apparatus)

Per standards C22.2 No. 0-10, C22.2 No. 0.4-M2004, C22.2 No. 94-M1991, C22.2 No. 142 – M1987, C22.2 No 157 – M1992, CAN/CSA E60079-0:07, CAN/CSA E60079- 11:02, UL50 11th Ed, UL508 17th Ed, UL913 7th Ed, UL 60079-0: 2005, UL 60079-11: 2002

1.3 Ordering Information

The Rosemount 3900/3900VP General Purpose pH/ORP sensors feature a chemically resistant Ryton plastic body, along with a built-in solution ground for advanced diagnostics and a Pt-100 RTD for temperature compensation. These sensors are available with either an integral cable connection or Variopol (VP8) connector. Variopol cables sold separately (see [Accessories](#)).

Table 1-1: Rosemount 3900 pH/ORP Sensor ordering information

Model	Sensor Type
3900	pH/ORP Sensor
Preamplifier Option	
01	Preamplifier (1)
02	No preamplifier (2)
Measuring Electrode	
10	General Purpose Low Resistivity (GPLR) pH glass
12	Platinum ORP
Typical Model Number: 3900-01-10	

1. Preamplifier is SMART with -10 option and a standard preamplifier if with -12 option. Comes with 32 ft. (10 m) of integral cable.
2. Comes standard with 15 ft. (4.7 m) of integral cable.

Table 1-2: Rosemount 3900VP pH/ORP Sensor with Variopol cable connection ordering information

Model	Sensor Type
3900VP	pH/ORP Sensor
Preamplifier Option	
01	Preamplifier (1)
02	No preamplifier
Measuring Electrode	
10	General Purpose Low Resistivity (GPLR) pH glass
12	Platinum ORP
Typical Model Number: 3900VP-01-10	

1. Preamplifier is SMART with -10 option and a standard preamplifier if with -12 option.

Section 2: Installation

2.1 Storage

1. It is recommended that electrodes be stored in their original shipping containers until needed.
2. Do not store at temperatures below 14 °F (-10 °C).
3. Electrodes should be stored with a protective cap containing KCl solution (PN 9210342).
4. For overnight storage, immerse the sensor in tap water or 4 pH buffer solution.
5. pH glass electrodes slowly deteriorate in storage. There is no specific expiration date. However, the calibration procedure described below should be followed to determine that the sensor calibrates properly.

2.2 Electrode Preparation

1. Remove electrode from shipping container.
2. Remove the protective boot covering the electrode bulb.
3. Rinse away salt film with clean water; then shake the electrode so that the internal solution fills the bulb, thus removing any air trapped there.

2.3 Sensor Installation

1. Wrap the sensor threads with six or seven turns of Teflon tape to prevent leakage.
2. Do not over tighten the sensor into its receptacle.
3. Hand tighten the sensor, and then tighten one or two turns with a wrench.

Figure 2-1 Sensor Orientation

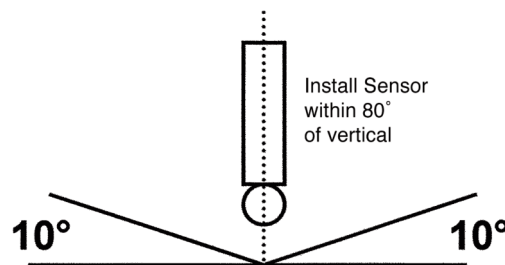

Figure 2-2 Rosemount 3900/3900VP Sensor Dimensions

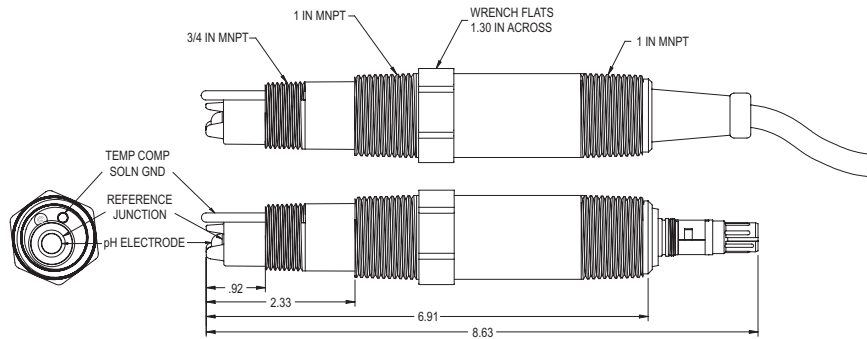
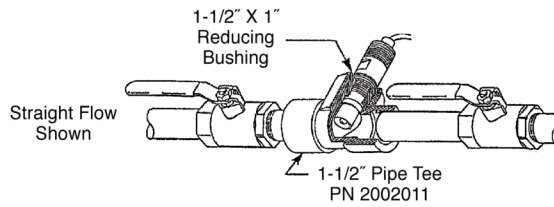

Figure 2-3 Typical flow through insertion installation using PN 2002011 Pipe Tee



Note: Sensor must be installed at least 10° above the horizon)

Horizontal Pipe Tee (PN 2002011)
 Pressure/Temperature Ratings

psig (kPa [abs])	°F (°C)
150 (1136)	150 (65)
128 (984)	160 (71)
102 (805)	170 (77)
80 (653)	180 (82)
57 (494)	200 (93)
48 (432)	210 (99)

Figure 2-4 Low Flow Cell PN 24091-00/24091-02

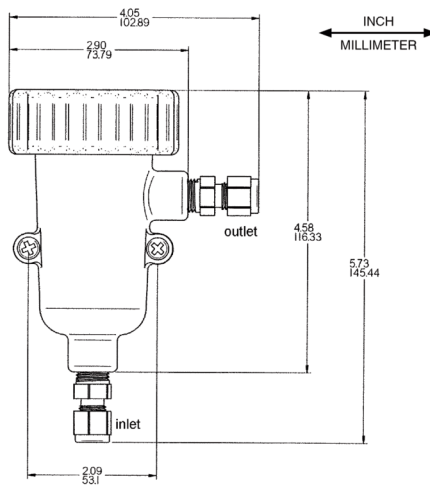

Inlet and outlet connections are stainless steel and take 1/4-inch OD tubing. Flow cell is polycarbonate with 1/4-inch FNPT fittings.

Wetted Materials:

Body and Nut: Polyester/Polycarbonate
 Fittings: 316 SST
 Seals: Silicone

Flow Cell Ratings:

Temperature: 32° to 158° F (0 to 70° C)
 Max. Pressure: 90 PSIG (721 kPa [abs])
 Flow rate: 2 to 5 GPH (7.6 to 18.9 LPH)

Sensor Threaded Connection:

24091-00: 1 inch NPT Adapter
 24091-02: 3/4 inch NPT Adapter"

Figure 2-5 Jet Spray Cleaner PN 12707-00

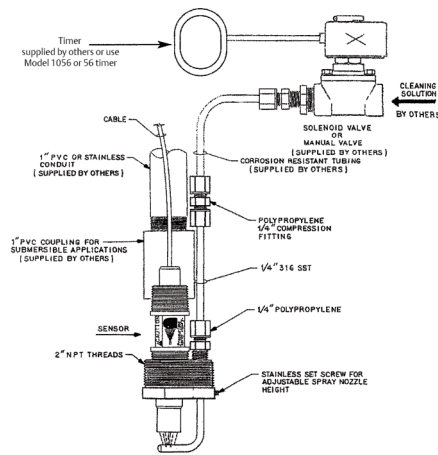

The jet spray cleaner eliminates routine, manual sensor maintenance by cleaning the sensor with water or compressed air. Flow through the cleaner can be controlled by a solenoid valve.

Note: The jet spray cleaner can be used with handrail mounting assembly (PN 11275-01, not shown) or can be mounted through conduit as shown below.

Jet Spray Cleaner with pH sensor



Note: Sensor must be installed at least 10° above the horizon)

Figure 2-6 Low Flow Panel PN SQP10077-LQD

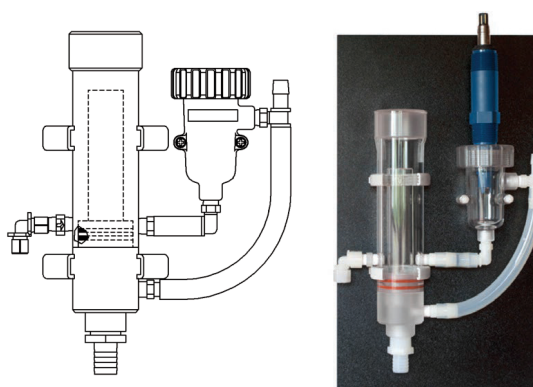

Low Flow Panel Specification	
Inlet flow	3-80 gph (11.4 – 304 L/hr)
Inlet pressure	3-65 psig (122 – 549 kPa abs)*
Temperature	32 to 122 °F (0 to 50 °C)

*The minimum inlet pressure is required to open a check valve, which prevents the flow cell from draining if sample flow is lost. Removing the check valve lowers the inlet pressure requirement to a few feet of water head.

2.3.1 Wiring

For additional wiring information on this product, including sensor combinations not shown here, please refer to the [Liquid Transmitter Wiring Diagrams](#).

Figure 2-7: Rosemount 3900/3900VP with Pre-amplifier to Rosemount 56/1056/1057/1066 Transmitter Wiring

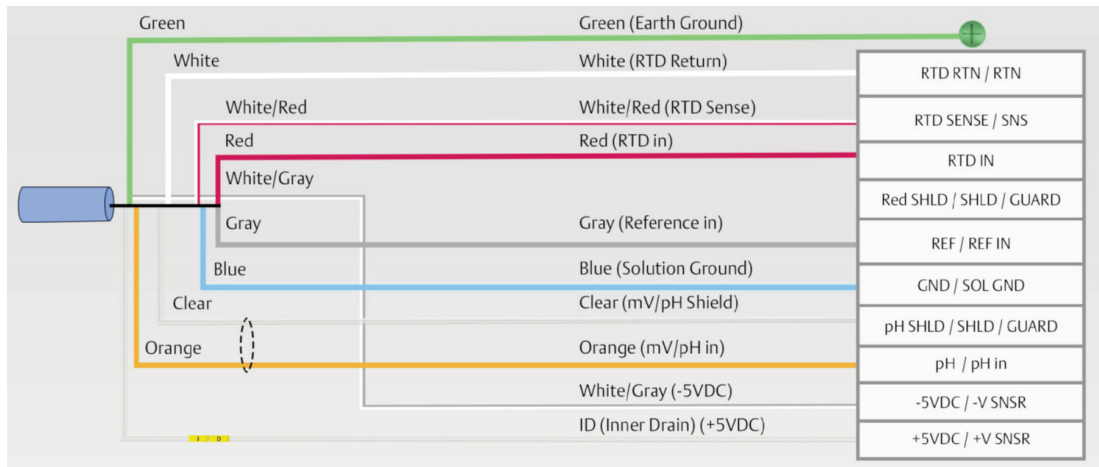

Figure 2-8: Rosemount 3900/3900VP with Pre-amplifier to Rosemount 56/1056/1057/1066 Transmitter, Junction Box without Pre-amplifier (PN 23550-00) Wiring

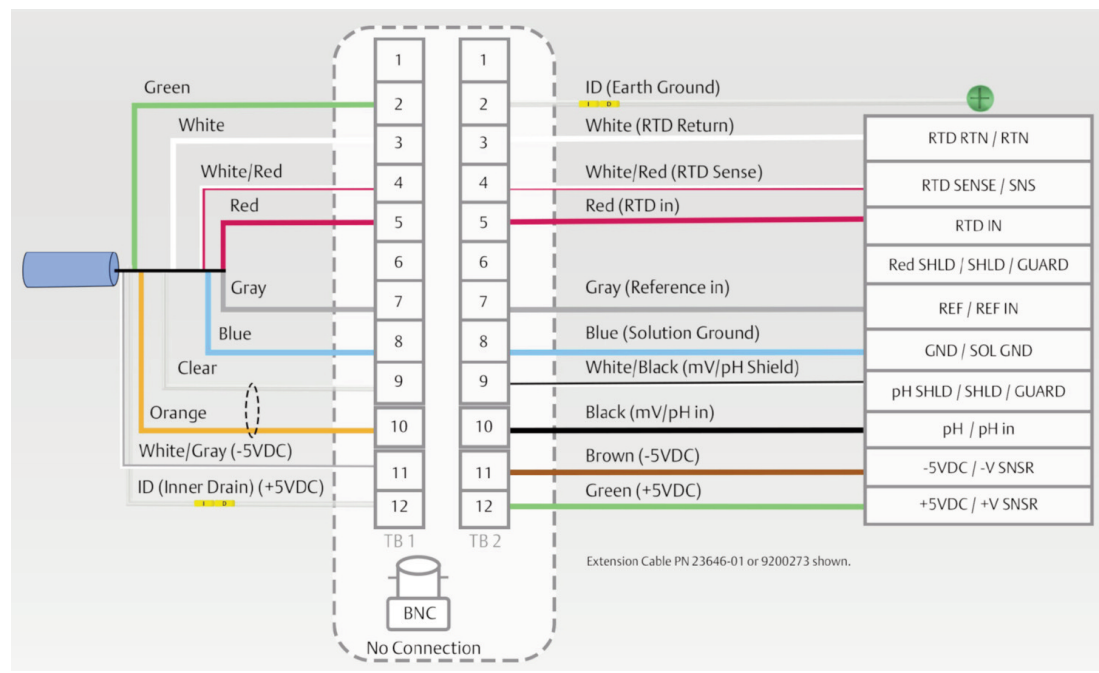

Figure 2-9: Rosemount 3900/3900VP without Preamp to Rosemount 56/1056/1057/1066 Transmitter Wiring

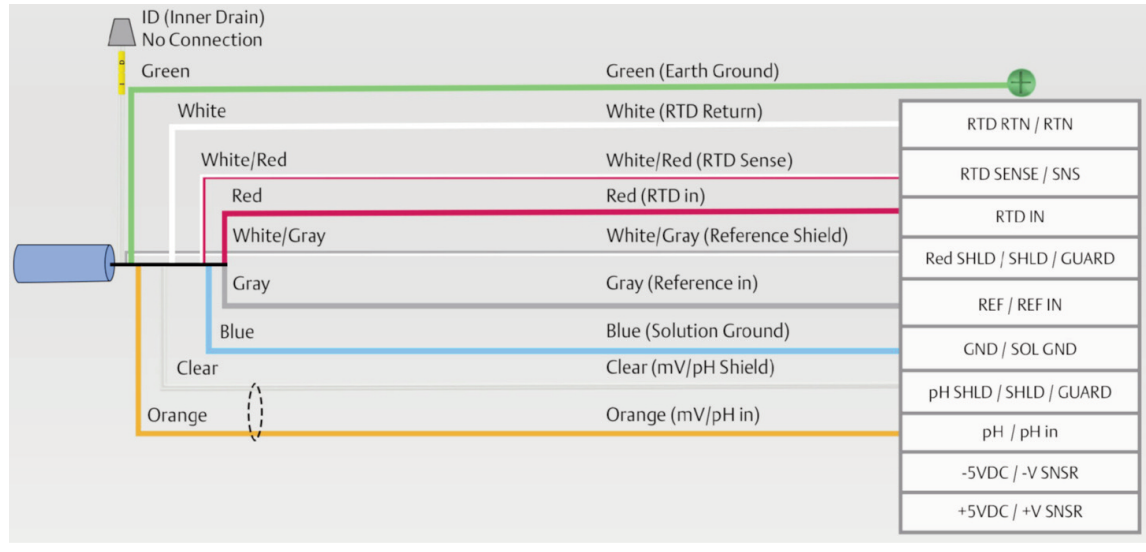

Figure 2-10: Rosemount 3900/3900VP without Preamp to Rosemount 56/1056/1057/1066 Transmitter, Junction Box with Preamp (PN 23555-00) Wiring

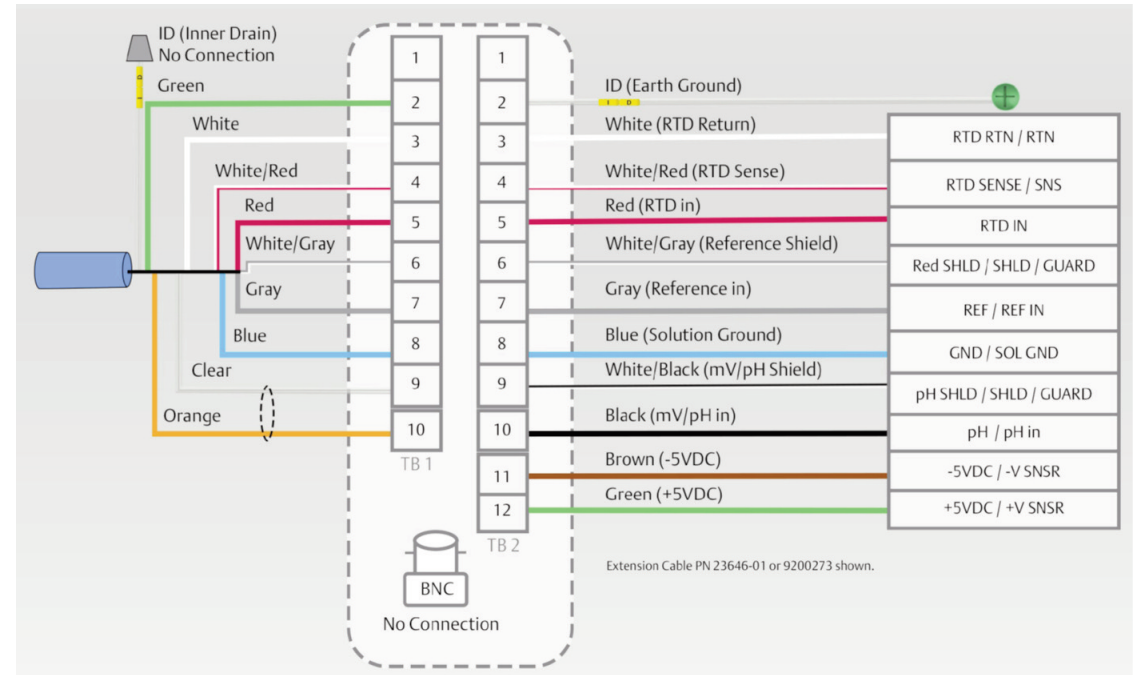

Figure 2-11: Rosemount 3900/3900VP with Preamplifier to Rosemount 5081 Transmitter Wiring

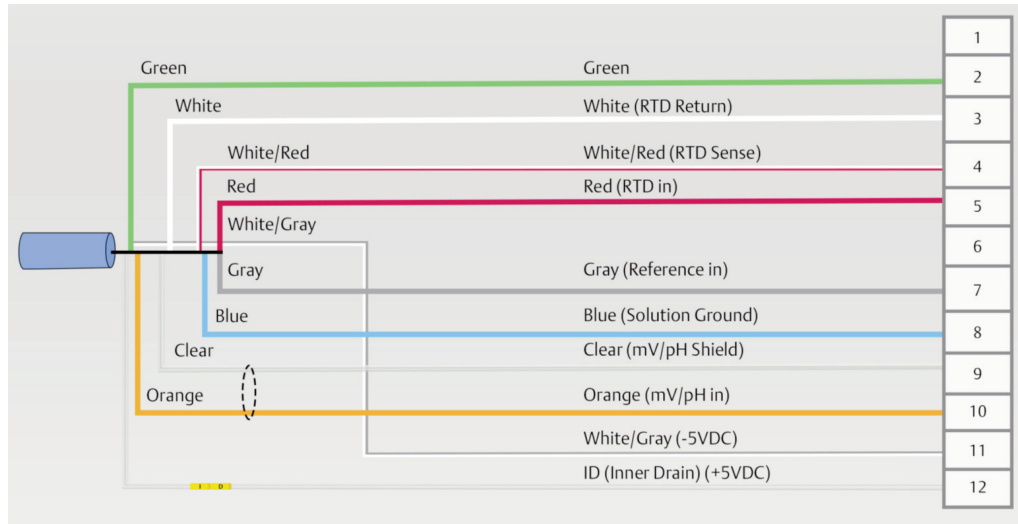

Figure 2-12: Rosemount 3900/3900VP with Preamplifier to Rosemount 5081 Transmitter, Junction Box without Preamplifier (PN 23550-00) Wiring

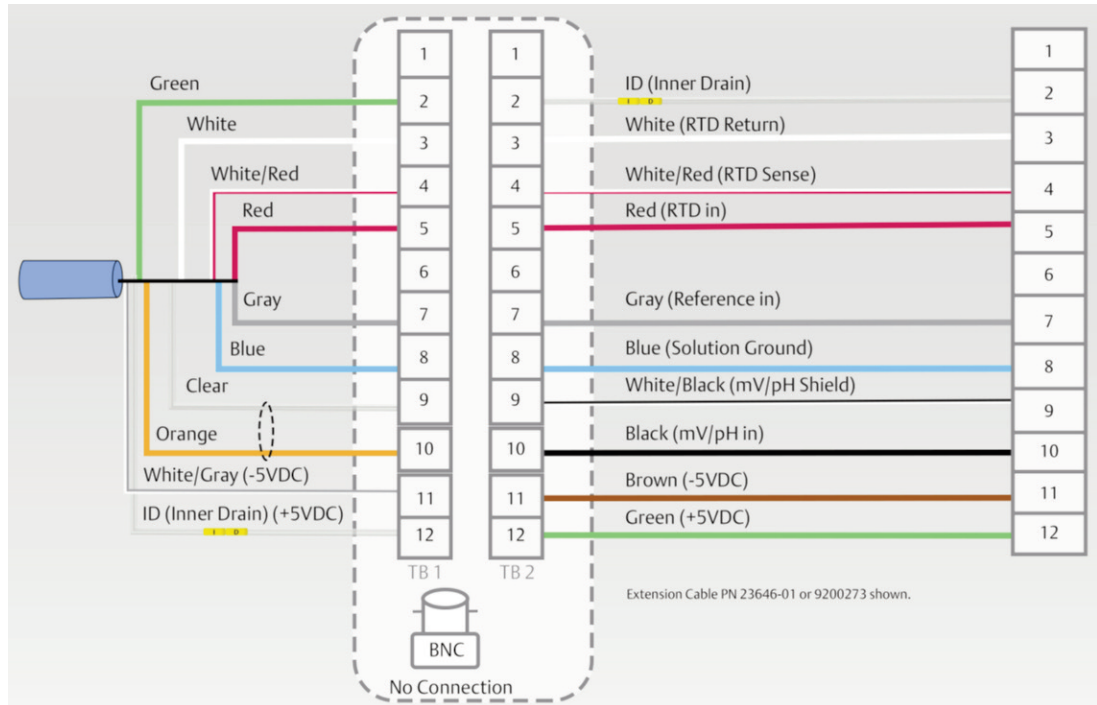
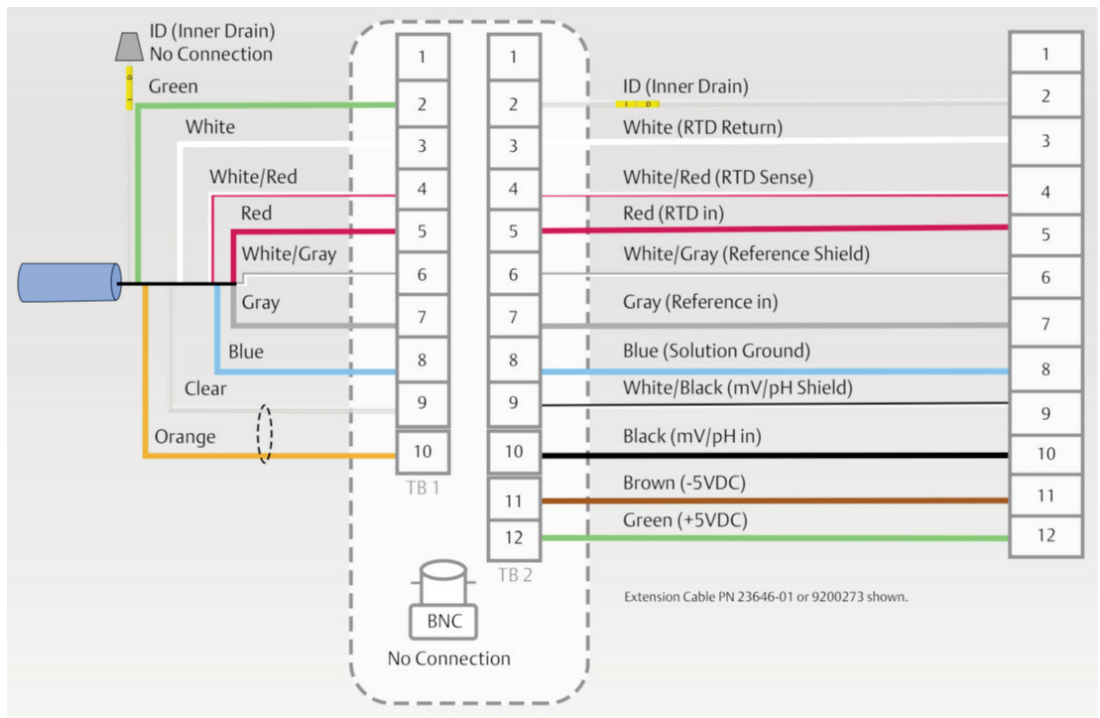

Figure 2-13: Rosemount 3900/3900VP without Pre-amplifier to Rosemount 5081 Transmitter Wiring



Figure 2-14: Rosemount 3900/3900VP without Pre-amplifier to Rosemount 5081 Transmitter, Junction Box with Pre-amplifier (PN 23555-00) Wiring



Section 3: Calibration and Maintenance

3.1 pH Two Point Buffer Calibration

Select two stable buffer solutions, preferably pH 4.0 and 7.0 (pH buffers other than pH 4.0 and pH 7.0 can be used as long as the pH values are at least two pH units apart).

NOTICE

A pH 7 buffer solution reads a mV value of approx. zero, and pH buffers read approximately ± 59.1 mV for each pH unit above or below pH 7. Check the pH buffer manufacturer specifications for millivolt values at various temperatures since it may affect the actual value of the buffer solution mV/pH value.

1. Immerse sensor in the first buffer solution. Allow sensor to equilibrate to the buffer temperature (to avoid errors due to temperature differences between the buffer solution and sensor temperature) and wait for reading to stabilize. Value of buffer can now be acknowledged by transmitter.
2. Once the first buffer has been acknowledged by the transmitter, rinse the buffer solution off the sensor with distilled or deionized water.
3. Repeat the steps 1 and 2 using the second buffer solution.
4. The theoretical slope value, according to the Nernst equation for calculating pH, is approximately 59.1 mV/pH. Over time the sensor will age, both in the process and in storage, which will result in reduced slope values. To ensure accurate readings, it is recommended that the electrode be replaced when the slope value falls below 47 to 49 mV/pH.

3.2 Recommended pH Sensor Standardization

For maximum accuracy, the sensor can be standardized on-line or with a process grab sample after a buffer calibration has been performed and the sensor has been conditioned to the process. Standardization accounts for the sensor junction potential and other interferences. Standardization will not change the sensors slope, but will simply adjust the transmitter's reading to match that of the known process pH.

3.3 pH Electrode Maintenance

Electrodes should respond rapidly. Sluggishness, offsets, and erratic readings are indicators that the electrodes may need cleaning or replacement.

1. To remove oil deposit, clean the electrode with a mild non-abrasive detergent.
2. To remove scale deposits, soak electrodes for 1 to 5 minutes in a 5% hydrochloric acid solution.
3. Temperature effect on life expectancy: If glass electrode life expectancy is 100% at 77 °F (25 °C), then it will be approximately 25% at 176 °F (80 °C), and approximately 10% at 212 °F (100°C).

CAUTION

Hydrochloric acid is toxic and highly corrosive. Avoid skin contact; wear protective gloves. Use only in a well ventilated area. Do not inhale fumes. In case of an accident, consult a doctor immediately.

3.4 ORP Calibration

1. After making an electrical connection between the sensor and the instrument, obtain a standard solution of saturated quinhydrone PN R508-8OZ (475mV). This can also be made quite simply by adding a few crystals of quinhydrone to either pH 4 or pH 7 buffer. Quinhydrone is only slightly soluble; therefore only a few crystals will be required.
2. Immerse the sensor in the standard solution. Allow 1-2 minutes for the ORP sensor to stabilize.
3. Standardize the instrument to the solution value shown in the [Table 3-1](#) below. The resulting potentials, measured with a clean platinum electrode and saturated KCl/AgCl reference electrode, should be within +/- 20 millivolts of the value shown in the table below. Solution temperature must be noted to ensure accurate interpretation of results. The ORP value of saturated quinhydrone solution is not stable over long periods of time. Therefore, these standards should be made up fresh each time they are used.

Table 3-1 ORP of Saturated Quinhydrone Solution (millivolts)

	pH 4 Solution			pH 7 Solution		
Temperature °C	20	25	30	20	25	30
mV Potential	268	264	260	94	87	80

4. Remove the sensor from the buffer, rinse, and install in the process.

3.5 ORP Electrode Maintenance

Electrodes should respond rapidly. Sluggishness, offsets, and erratic readings are indicators that the electrodes may need cleaning or replacement.

1. To remove oil deposit, clean the electrode with a mild non-abrasive detergent.
2. To remove scale deposits, soak electrodes for 1 to 5 minutes in a 5% hydrochloric acid solution.
3. ORP (metallic) electrodes should be polished with moistened baking soda.

Section 4: Accessories

Table 4-1 Accessories Information

Part Number	Description
24281-00	15 ft. cable with mating VP8 connector
24281-01	25 ft. cable with mating VP8 connector
24281-02	2.5 ft. cable with mating VP8 connector
24281-03	50 ft. cable with mating VP8 connector
24281-04	100 ft. cable with mating VP8 connector
24281-05	4 ft. cable with mating VP8 connector
24281-06	10 ft. cable with mating VP8 connector
24281-07	20 ft. cable with mating VP8 connector
24281-08	30 ft. cable with mating VP8 connector
12707-00	Jet Spray Cleaner
23242-02	Insertion Mounting Adapter, 1.5" MNPT Process Connection, 1" x 3/4" FPT Sensor Adapter/Union Thread Size
24091-00	Low flow cell, 1" NPT Adapter
24091-02	Low flow cell, 3/4" NPT Adapter
23555-00	Weatherproof Junction Box, with Pre-amplifier
2002011	CPVC In-Line Tee, 1.5" Size, 1.0" Threaded Process Connection
11275-01	Handrail Mounting Assembly
9210012	pH 4.01 Buffer Solution, 16 oz
9210013	pH 6.86 Buffer Solution, 16 oz
9210014	pH 9.18 Buffer Solution, 16 oz
9200273	Conductor Extension Cable, Shielded and Unprepped (for use with Remote Junction Box)
SQP10077-LQD	Low Flow Control Panel

Note: Please see [website](#) for most recent Declaration.



EU Declaration of Conformity



(No. 1700911)

pH/ORP Sensors

This declaration is issued under the sole responsibility of the manufacturer:
Rosemount Inc., 8200 Market Blvd., Chanhassen, MN 55317 USA

The sensor models:

328A, 385, 385+ -04, 385+ -02/03, 385+ -03-12, 389-01, 389-01-10/11-50, 389-01-10/11-54, 389-01-12-50, 389-01-12-54, 389-01-12-55, 389-02, 389VP, 389VP-70, 396, 396P-01-10/13-50, 396P-01-10/13-54, 396P-01-12-50, 396P-01-12-54, 396P-01-12-55, 396P-01-55, 396VP, 396VP-70, 396R, 396RVP, 396RVP-70, 396P-02, 396PVP, 396PVP-70, 397, 398, 398VP, 398R, 398RVP, 398RVP-70, 3200HP, 3300HT, 3300HT VP, 3300HTVP-70, 3400HT, 3400HT VP, 3400HTVP-70, 3500P-01, 3500P-01-12, 3500P-02, 3500VP-01, 3500VP-01-12, 3500VP-02, 3800, 3800VP, 3900-01, 3900-02, 3900VP-01, 3900VP-02

to which this declaration relates, are in conformity with relevant Union harmonization legislation:
(2014/34/EU) ATEX Directive

Intrinsically Safe, Examination Certificate: Baseefa10ATEX0156X

Provisions of the directive fulfilled by the equipment:
Equipment Group II, Category 1 G Ex ia IIC T4 Ga (-20°C ≤ Ta ≤ +60°C) exceptions noted below

Model 328A Steam sterilizable pH sensor with integral cable
Model 385 Retractable pH/ORP sensor with integral cable
Model 385+ -04 pH/ORP sensor with integral cable
Model 385+ -02/03 pH/ORP sensor with integral cable & Smart preamplifier
Model 385+ -03-12 ORP sensor with integral cable & preamplifier: T4 (-20°C ≤ Ta ≤ +80°C), T5 (-20°C ≤ Ta ≤ +40°C)
Model 389-01 pH sensor with integral cable & Smart preamplifier
Model 389-01-10/11-50 pH sensor with integral cable & preamplifier: T4 (-20°C ≤ Ta ≤ +80°C) or T5 (-20°C ≤ Ta ≤ +40°C)
Model 389-01-10/11-54 pH sensor with integral cable & preamplifier: T4 (-20°C ≤ Ta ≤ +80°C) or T5 (-20°C ≤ Ta ≤ +40°C)
Model 389-01-12-50 ORP sensor with integral cable & preamplifier: T4 (-20°C ≤ Ta ≤ +80°C)
Model 389-01-12-54 ORP sensor with integral cable & preamplifier: T4 (-20°C ≤ Ta ≤ +80°C)
Model 389-01-12-55 ORP sensor with integral cable & preamplifier: T4 (-20°C ≤ Ta ≤ +80°C)
Model 389-02 pH/ORP sensor with integral cable
Model 389VP-70 pH sensor with Variopole connector & Smart preamplifier
Model 389VP pH/ORP sensor with Variopole connector
Model 396 TU pH sensor with integral cable
Model 396P-01-10/13-50 polypropylene pH sensor with integral cable & preamp: T4 (-20°C ≤ Ta ≤ 80°C) or T5 (-20°C ≤ Ta ≤ 40°C)
Model 396P-01-10/13-54 polypropylene pH sensor with integral cable & preamp: T4 (-20°C ≤ Ta ≤ 80°C) or T5 (-20°C ≤ Ta ≤ 40°C)
Model 396P-01-12-50 ORP sensor with integral cable & preamp: T4 (-20°C ≤ Ta ≤ +80°C)
Model 396P-01-12-54 ORP sensor with integral cable & preamp: T4 (-20°C ≤ Ta ≤ +80°C)
Model 396P-01-12-55 ORP sensor with integral cable & preamp: T4 (-20°C ≤ Ta ≤ +80°C)
Model 396P-01-55 pH sensor with integral cable & Smart preamp
Model 396VP TU pH sensor with Variopole connector
Model 396VP-70 TU pH sensor with Variopole connector & Smart preamplifier
Model 396R TU pH Retractable pH/ORP sensor with integral cable
Model 396RVP TU pH Retractable pH/ORP sensor with Variopole connector
Model 396RVP-70 TU pH Retractable pH sensor with Variopole connector & Smart preamplifier
Model 396P-02 TU pH Polypropylene pH/ORP sensor with integral cable
Model 396PVP TU pH Polypropylene pH/ORP sensor with Variopole connector
Model 396PVP-70 TU pH Polypropylene pH sensor with Variopole connector & Smart preamplifier
Model 397 TU pH sensor with integral cable
Model 398 TU pH pH/ORP sensor with integral cable
Model 398VP TU pH pH/ORP sensor with Variopole connector
Model 398R TU pH Retractable pH/ORP sensor with integral cable
Model 398RVP TU pH Retractable pH/ORP sensor with Variopole connector
Model 398RVP-70 TU pH Retractable pH sensor with Variopole connector & Smart preamplifier
Model 3200HP Flowing junction pH sensor with Variopole connector
Model 3300HT Insertion/submersion pH sensor with integral cable
Model 3300HTVP Insertion/submersion pH sensor with Variopole connector
Model 3300HTVP-70 Insertion/submersion pH sensor with Variopole connector & Smart preamplifier
Model 3400HT Retractable pH sensor with integral cable
Model 3400HTVP Retractable pH sensor with Variopole connector
Model 3400HTVP-70 Retractable pH sensor with Variopole connector & Smart preamplifier
Model 3500P-01 High performance pH sensor with integral cable & Smart preamplifier
Model 3500P-01-12 PerpH-X ORP sensor with integral cable & preamplifier: T4 (-20°C ≤ Ta ≤ +80°C)
Model 3500P-02 High performance pH sensor with integral cable
Model 3500VP-01 High performance pH sensor with Variopole connector & Smart preamplifier
Model 3500VP-01-12 PerpH-X ORP sensor with Variopole connector & preamplifier: T4 (-20°C ≤ Ta ≤ +80°C)
Model 3500VP-02 High performance pH sensor with Variopole connector
Model 3800 Steam sterilizable pH sensor with single pole Eurocap connector

Model 3800VP Steam sterilizable pH sensor with Variopole connector
Model 3900-01 pH/ORP sensor with integral cable & Smart preamplifier
Model 3900-02 pH/ORP sensor with integral cable
Model 3900VP-01 pH sensor with Variopole connector & Smart preamplifier
Model 3900VP-02 pH/ORP sensor with Variopole connector

Special conditions for safe use:

- 1) All pH/ORP sensor models with a plastic enclosure or exposed plastic parts may provide an electrostatic ignition hazard and must only be cleaned with a damp cloth to avoid the danger of ignition due to a build up of electrostatic charge.
- 2) All pH/ORP sensor models with a metallic enclosure may provide a risk of ignition by impact or friction. Care should be taken during installation to protect the sensor from this risk.
- 3) External connections to the sensor must be suitably terminated and provide a degree of protection of at least IP20.

All pH/ORP sensor models are intended to be in contact with the process fluid and may not meet the 500V r.m.s test to earth. This must be taken into consideration at installation.

ATEX Notified Body for EC Type Examination Certificate & Quality Assurance:

SGS Baseefa[Notified Body Number:1180], Rockhead Business Park, Staden Lane, Buxton SK17 9RZ UNITED KINGDOM

Assumption of conformity is based on the application of the harmonized standards:

EN 60079-0:2012+A11:2013 Explosive atmospheres. Equipment. General requirements

EN 60079-11:2012 Explosive atmospheres. Equipment protection by intrinsic safety "i"



(Signature)

Kim Freeman
(Name printed)

Director of Global Quality
(Function name)

March 23, 2017
(Date of issue)

CE marking was first affixed to this product in 2011

Intrinsically Safe Sensor Installation Drawing - FM

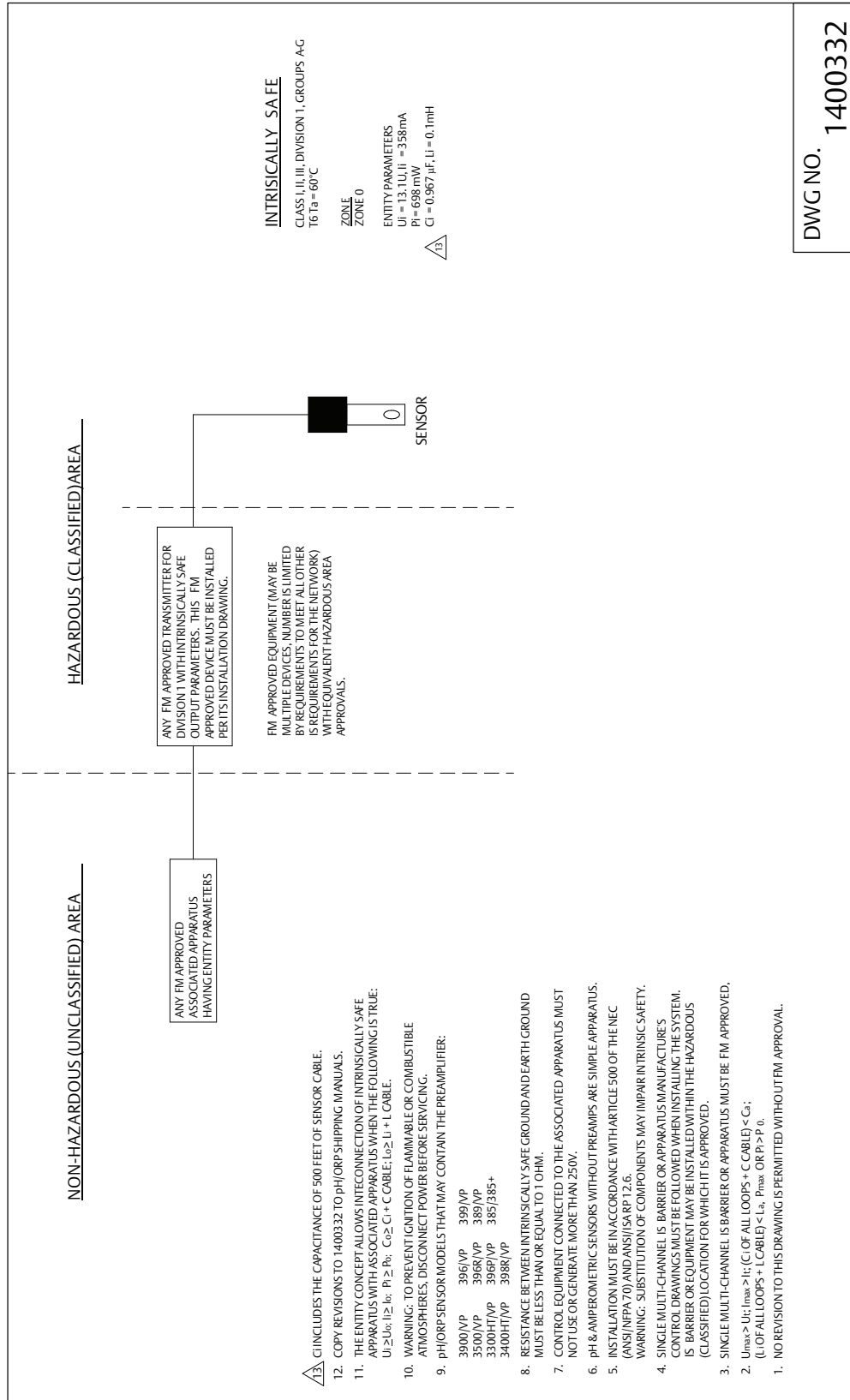

DWG NO. 1400332

www.Emerson.com/RosemountLiquidAnalysis



[Youtube.com/user/Rosemount](https://www.youtube.com/user/Rosemount)



Analyticexpert.com



[Twitter.com/Rosemount_News](https://twitter.com/Rosemount_News)



facebook.com/Rosemount

Emerson

8200 Market Blvd.
Chanhassen, MN 55317,
USA
Tel +1 800 999 9307
Fax +1 952 949 7001

Liquid.CSC@Emerson.com

©2017 Emerson. All rights reserved.

The Emerson logo is a trademark and service mark of Emerson Electric Co. Rosemount is a mark of one of the Emerson family of companies. All other marks are the property of their respective owners.

The contents of this publication are presented for information purposes only, and while effort has been made to ensure their accuracy, they are not to be construed as warranties or guarantees, express or implied, regarding the products or services described herein or their use or applicability. All sales are governed by our terms and conditions, which are available on request. We reserve the right to modify or improve the designs or specifications of our products at any time without notice.

ROSEMOUNT™

