

Blanketing Valve

low pressure reducing valve

ZM-R

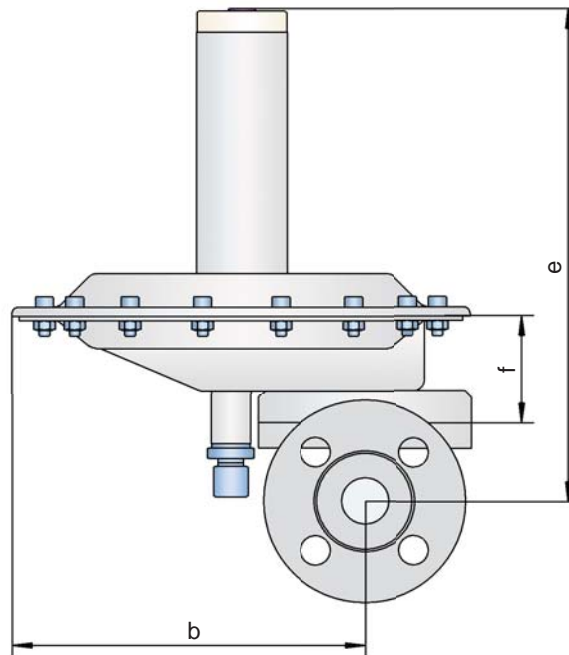
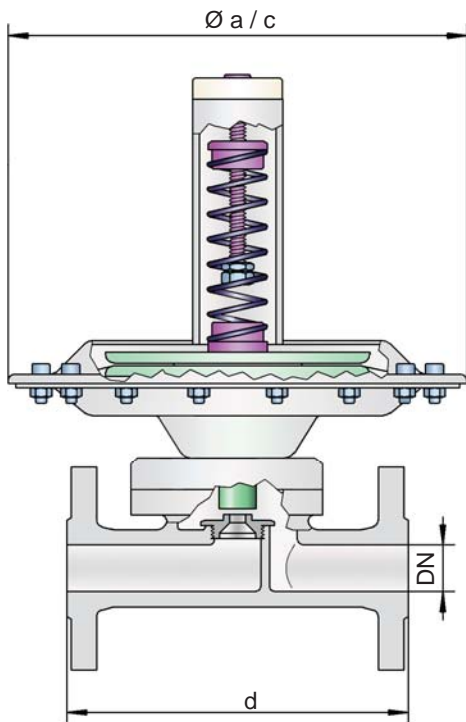

Pressure range:

Supply pressure:
up to +16 bar /
+6424 inch W.C.

Set pressure for
overpressure function:
up to +500 mbar /
+200 inch W.C.

Set pressure for
vacuum function:
up to -200 mbar /
-80 inch W.C.

Function and Description

The blanketing valve type ZM-R is a highly developed low pressure reducing valve. This valve is typically used to inert or blanket tanks, vessels or other process systems with nitrogen or other blanketing gases by controlling the tank pressure to its desired value. High nitrogen or blanketing gas supply pressures up to 16 bar / 232 psi are safely reduced down to only a few mbar / inch W.C..

The ZM-R low pressure reducing valve is a direct acting one stage pressure control device. It is designed as a membrane controlled, spring loaded proportional acting valve. The valve controls the tank pressure by increasing flow as the tank pressure drops. This means that the mass flow through the device depends on the pressure differential of the set pressure to the actual tank pressure. When the actual tank pressure reaches the set pressure the control unit closes and there is no flow.

At the control membrane (which can be made from PTFE or Viton) the tank pressure (P_2) is balanced with the adjustment spring and the supply pressure (P_1).

In a depressurized tank the adjustment spring holds the valve pallet in the fully open position. As the tank pressure increases the valve pallet moves toward the seat and the mass flow is reduced. When the desired tank pressure is reached the device will close.

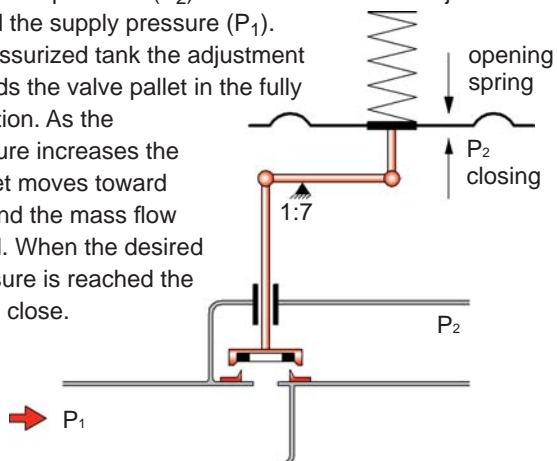

Should the tank pressure decrease the valve will open. If the plant is operated in a vacuum mode pressures down to -200 mbar / -80 inch W.C. relative pressure can be accommodated.

Special features and advantages

- one stage pressure reduction within a relatively high pressure range
- large membrane surface to increase the closing force
- all functional and wetted parts are made of stainless steel (or hastelloy if required)
- easy adjustment of set pressure (within the pressure range of the specific spring)
- vertical or horizontal installation (set pressure has to be adjusted for horizontal installation)
- no external energy supply required
- optimized flow performance, which reduces capital cost to a minimum as smaller sized vents are needed
- the valve pallet is guided within the housing to protect against harsh weather conditions, e.g. preventing freezing of pallet in cold weather conditions
- reducing within the vacuum range is possible
- high accuracy
- can be installed in explosion hazardous areas
- housing designed to 16 bar / 150 psi
- maintenance friendly design

Design and Specification

Two different designs are available:

Blanketing valve for overpressure, standard design **ZM-R**

Blanketing valve for vacuum, standard design **ZM-R** /

Other special devices can be supplied on request

For in-line valves any back pressure, which will influence the set pressure and opening characteristics, has to be taken into account.

Table 1: Dimensions		Dimensions in mm				Dimensions in inches			
To select the nominal size (DN), please use the flow rates on the following pages									
DN	15 / 1/2"	25 / 1"	50 / 2"	100 / 4"	15 / 1/2"	25 / 1"	50 / 2"	100 / 4"	
a	214	214	–	–	8.43	8.43	–	–	
b	168	168	–	–	6.61	6.61	–	–	
c*	–	–	214 / 360	360 / 600	–	–	8.43 / 14.17	14.17 / 23.62	
d	EN	150	160	150	250 / 250	5.91	6.3	5.91	9.84 / 9.84
	ASME	180	160	150	250 / 250	7.09	6.3	5.91	9.84 / 9.84
e	214	214	230	275 / 310	8.43	8.43	9.06	10.83 / 12.2	
f	87	87	103	148 / 155	3.43	3.43	4.06	5.83 / 6.10	

* depends upon size of diaphragm

Table 2: Material selection for housing				
Design	S	H	Optional: Inner part of housing electropolished Special materials upon request	
Housing	Stainless Steel	Hastelloy		
Valve seat	Stainless Steel	Hastelloy		
Valve pallet	Stainless Steel	Hastelloy		
Valve seat sealing	FFKM	FFKM		
Gasket	PTFE	PTFE		
Diaphragm P	PTFE	PTFE		Marking P
Alternative: Diaphragm V	Viton	-		Marking V

Table 3: Selection for valve seat (depending on flow rate)			
Size	Seat in mm / inches	Kvs	Number
25 / 1"	2,0 / 0.08	0,15	20
	4,5 / 0.18	0,60	45
	7,5 / 0.30	1,20	75
	10,0 / 0.39	1,70	100
	14,0 / 0.55	2,40	140
50 / 2"	14,0 / 0.55	3,00	140
	18,0 / 0.71	7,00	180
	26,0 / 1.02	15,00	260
100 / 4"	42,0 / 1.65	35,00	420
	55,0 / 2.17	70,00	550

* 1 Kvs = 0.86 Cv; 1 Cv = 1.17 Kvs



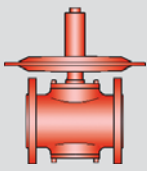

In-Line Pressure Reducing Valve

low pressure reducing valve

ZM-R

Table 4: Connection type

FD	EN 1092-1; Form B1	EN	other types upon request
FA	ASME B16.5; 150 lbs RFSF	ASME	
G	Thread	G or NPT	

Flow rates for P2 pressure range (Europe – metric units)

ZM-R 15 / ZM-R 25: flow rate (air, 0°C) at $\square P = P1 - P2$ and valve full open											
overpressure P1 (bar) P2 (mbar)	0,15	0,25	0,40	0,65	1,00	1,50	2,50	4,00	6,00	10,00	Seat-Ø
	[Nm ³ /h]	[Nm ³ /h]	[Nm ³ /h]	[Nm ³ /h]	[Nm ³ /h]	[Nm ³ /h]	[Nm ³ /h]	[Nm ³ /h]	[Nm ³ /h]	[Nm ³ /h]	[mm]
10	6,2 12,4 17,5 24,8	8,1 16,2 23,0 32,5	10,3 20,7 29,3 41,4	13,2 26,5 37,6 53,1	16,5 33,0 46,7 66,0	20,6 41,2 58,4 82,4	28,8 57,6 81,6 115,2	41,1 82,2 116,5 164,5	57,5 115,0 163,0 230,1	90,3 180,7 256,0 361,4	Ø 4,5 Ø 7,5 Ø 10,0 Ø 14,0
20	6,0 12,0 17,0 24,0	7,9 15,9 22,6 31,9	10,2 20,5 29,1 41,1	13,2 26,4 37,5 52,9	16,5 33,0 46,7 66,0	20,6 41,2 58,4 82,4	28,8 57,6 81,6 115,2	41,1 82,2 116,5 164,5	57,5 115,0 163,0 230,1	90,3 180,7 256,0 361,4	Ø 4,5 Ø 7,5 Ø 10,0 Ø 14,0
100	3,8 7,7 10,9 15,4	6,7 13,4 18,9 26,8	9,4 18,9 26,8 37,9	12,8 25,6 36,3 51,3	16,4 32,8 46,5 65,6	20,6 41,2 58,4 82,4	28,8 57,6 81,6 115,2	41,1 82,2 116,5 164,5	57,5 115,0 163,0 230,1	90,3 180,7 256,0 361,4	Ø 4,5 Ø 7,5 Ø 10,0 Ø 14,0
200	- - - -	4,0 8,0 11,4 16,1	8,0 16,1 22,9 32,3	12,1 24,2 34,3 48,4	16,1 32,3 45,8 64,6	20,6 41,2 58,4 82,4	28,8 57,6 81,6 115,2	41,1 82,2 116,5 164,5	57,5 115,0 163,0 230,1	90,3 180,7 256,0 361,4	Ø 4,5 Ø 7,5 Ø 10,0 Ø 14,0
500	- - - -	- - - -	- - - -	7,8 15,6 22,1 31,2	14,2 28,5 40,4 57,0	20,1 40,3 57,1 80,7	28,8 57,6 81,6 115,2	41,1 82,2 116,5 164,5	57,5 115,0 163,0 230,1	90,3 180,7 256,0 361,4	Ø 4,5 Ø 7,5 Ø 10,0 Ø 14,0

ZM-R 50: flow rate (air, 0°C) at $\Delta P = P1 - P2$ and valve full open											
overpressure P1 (bar) P2 (mbar)	0,15	0,25	0,40	0,65	1,00	1,50	2,50	4,00	6,00	10,00	Seat-Ø
	[Nm ³ /h]	[Nm ³ /h]	[Nm ³ /h]	[Nm ³ /h]	[Nm ³ /h]	[Nm ³ /h]	[Nm ³ /h]	[Nm ³ /h]	[Nm ³ /h]	[Nm ³ /h]	[mm]
10	28,9 70,3 150,0	37,9 92,1 196,5	48,3 117,4 250,4	61,9 150,4 320,8	77,0 187,1 399,1	96,2 233,6 498,3	134,5 326,6 696,5	191,9 466,1 994,0	268,5 652,1 1390	421,6 1024 2183	Ø 14,0 Ø 18,0 Ø 26,0
20	28,0 68,1 145,3	37,3 90,6 193,3	47,9 116,5 248,4	61,7 150,0 319,9	77,0 187,1 399,0	96,2 233,6 498,3	134,5 326,6 696,5	191,9 466,1 994,0	268,5 652,1 1390	421,6 1024 2183	Ø 14,0 Ø 18,0 Ø 26,0
100	18,0 43,8 93,5	31,2 75,9 162,0	44,2 107,4 229,1	59,9 145,5 310,2	76,6 186,1 396,9	96,2 233,6 498,3	134,5 326,6 696,5	191,9 466,1 994,0	268,5 652,1 1390	421,6 1024 2183	Ø 14,0 Ø 18,0 Ø 26,0
200	- - -	18,8 45,8 97,6	37,7 91,6 195,3	56,5 137,4 293,0	75,4 183,2 390,6	96,2 233,6 498,3	134,5 326,6 696,5	191,9 466,1 994,0	268,5 652,1 1390	421,6 1024 2183	Ø 14,0 Ø 18,0 Ø 26,0
500	- - -	- - -	- - -	36,4 88,6 188,9	66,6 161,7 344,9	94,1 228,7 487,8	134,5 326,6 696,5	191,9 466,1 994,0	268,5 652,1 1390	421,6 1024 2183	Ø 14,0 Ø 18,0 Ø 26,0

ZM-R 100: flow rate (air, 0°C) at $\Delta P = P1 - P2$ and valve full open											
overpressure P1 (bar) P2 (mbar)	0,15	0,25	0,40	0,65	1,00	1,50	2,50	4,00	6,00	10,00	Seat-Ø
	[Nm ³ /h]	[Nm ³ /h]	[Nm ³ /h]	[Nm ³ /h]	[Nm ³ /h]	[Nm ³ /h]	[Nm ³ /h]	[Nm ³ /h]	[Nm ³ /h]	[Nm ³ /h]	[mm]
10	346 703	453 921	587 1174	741 1504	922 1871	1151 2336	1609 3266	2296 4661	3212 6512	5045 10241	Ø 42,0 Ø 55,0
20	335 681	446 906	574 1165	739 1500	921 1871	1151 2336	1609 3266	2296 4661	3212 6512	5045 10241	Ø 42,0 Ø 55,0
100	216 438	374 759	529 1074	716 1455	917 1861	1151 2336	1609 3266	2296 4661	3212 6512	5045 10241	Ø 42,0 Ø 55,0
200	- -	225 458	451 916	676 1374	902 1832	1151 2336	1609 3266	2296 4661	3212 6512	5045 10241	Ø 42,0 Ø 55,0
500	- -	- -	- -	436 886	796 1617	1127 2287	1609 3266	2296 4661	3212 6512	5045 10241	Ø 42,0 Ø 55,0

Flow rates for P2 vacuum range (Type ZM-R/N) upon request



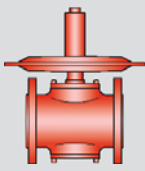

In-Line Pressure Reducing Valve

Flow rates for P2 pressure range (english/american units – non-metric)

ZM-R

ZM-R 15 / ZM-R 25: flow rate (air, 32°F) at $\square P = P1 - P2$ and valve full open											
overpressure P1 (psi) P2 ("wc)	2.18	3.63	5.80	9.43	14.50	21.76	36.26	58.02	87.02	145.04	Seat-Ø
	[SCFH]	[SCFH]	[SCFH]	[SCFH]	[SCFH]	[SCFH]	[SCFH]	[SCFH]	[SCFH]	[SCFH]	[inch]
3.94	219	287	366	469	583	728	1018	1453	2032	3191	Ø 0.18
	439	574	732	938	1166	1456	2036	2905	4064	6382	Ø 0.29
	621	814	1037	1329	1652	2063	2884	4116	5758	9042	Ø 0.39
	877	1149	1464	1876	2333	2913	4072	5810	8128	12764	Ø 0.55
7.87	212	282	363	468	583	728	1018	1453	2032	3191	Ø 0.18
	425	565	726	935	1166	1456	2036	2905	4064	6382	Ø 0.29
	602	800	1029	1325	1652	2063	2884	4116	5758	9042	Ø 0.39
	849	1130	1452	1870	2333	2913	4072	5810	8128	12764	Ø 0.55
39.4	137	237	335	453	580	728	1018	1453	2032	3191	Ø 0.18
	273	474	670	907	1166	1456	2036	2905	4064	6382	Ø 0.29
	387	671	949	1285	1643	2063	2884	4116	5758	9042	Ø 0.39
	547	947	1339	1814	2320	2913	4072	5810	8128	12764	Ø 0.55
78.7	-	143	285	428	571	728	1018	1453	2032	3191	Ø 0.18
	-	285	571	856	1142	1456	2036	2905	4064	6382	Ø 0.29
	-	404	809	1213	1617	2063	2884	4116	5758	9042	Ø 0.39
	-	571	1142	1713	2284	2913	4072	5810	8128	12764	Ø 0.55
196.9	-	-	-	276	504	713	1018	1453	2032	3191	Ø 0.18
	-	-	-	552	1108	1426	2036	2905	4064	6382	Ø 0.29
	-	-	-	782	1428	2020	2884	4116	5758	9042	Ø 0.39
	-	-	-	1104	2016	2851	4072	5810	8128	12764	Ø 0.55

ZM-R 50: flow rate (air, 32°F) at $\square P = P1 - P2$ and valve full open											
overpressure P1 (psi) P2 ("wc)	2.18	3.63	5.80	9.43	14.50	21.76	36.26	58.02	87.02	145.04	Seat-Ø
	[SCFH]	[SCFH]	[SCFH]	[SCFH]	[SCFH]	[SCFH]	[SCFH]	[SCFH]	[SCFH]	[SCFH]	[inch]
3.94	1023	1340	1708	2188	2722	3398	4750	6779	9483	14892	Ø 0.55
	2486	3254	4149	5314	6610	8253	11536	16462	23030	36166	Ø 0.71
	5300	6939	8846	11332	14094	17597	24600	35104	49109	77119	Ø 1.02
7.87	991	1318	1694	2182	2721	3398	4750	6779	9483	14892	Ø 0.55
	2407	3201	4115	5298	6608	8253	11536	16462	23030	36166	Ø 0.71
	5132	6827	8775	11298	14091	17597	24600	35104	49109	77119	Ø 1.02
39.4	638	1105	1563	2116	2707	3398	4750	6779	9483	14892	Ø 0.55
	1549	2684	3795	5139	6573	8253	11536	16462	23030	36166	Ø 0.71
	3304	5722	8093	10958	14017	17597	24600	35104	49109	77119	Ø 1.02
78.7	-	666	1332	1998	2664	3398	4750	6779	9483	14892	Ø 0.55
	-	1617	3235	4852	6470	8253	11536	16462	23030	36166	Ø 0.71
	-	3449	6898	10347	13796	17597	24600	35104	49109	77119	Ø 1.02
196.9	-	-	-	1288	2352	3327	4750	6779	9483	14892	Ø 0.55
	-	-	-	3129	5713	8079	11536	16462	23030	36166	Ø 0.71
	-	-	-	6672	12181	17227	24600	35104	49109	77119	Ø 1.02

ZM-R 100: flow rate (air, 32°F) at $\Delta P = P1 - P2$ and valve full open											
overpressure P1 (psi) P2 ("wc)	2.18	3.63	5.80	9.43	14.50	21.76	36.26	58.02	87.02	145.04	Seat-Ø
	[SCFH]	[SCFH]	[SCFH]	[SCFH]	[SCFH]	[SCFH]	[SCFH]	[SCFH]	[SCFH]	[SCFH]	[inch]
3.94	12245 24856	16033 32544	20438 41485	26181 53144	32562 66097	40656 82525	56834 115365	81101 164624	113458 230303	178171 361660	Ø 1.65 Ø 2.17
7.87	11857 24068	15772 32014	20272 41150	26102 52984	32555 66082	40656 82525	56834 115365	81101 164624	113458 230303	178171 361660	Ø 1.65 Ø 2.17
39.4	7633 15494	13221 26836	18697 37952	25316 51387	32384 65735	40656 82525	56834 115365	81101 164624	113458 230303	178171 361660	Ø 1.65 Ø 2.17
78.7	- -	7968 16175	15937 32350	23905 48525	31874 64699	40656 82525	56834 115365	81101 164624	113458 230303	178171 361660	Ø 1.65 Ø 2.17
196.9	- -	- -	- -	15414 31289	28142 57125	39800 80788	56834 115365	81101 164624	113458 230303	178171 361660	Ø 1.65 Ø 2.17

Flow rates for P2 vacuum range (Type ZM-R/N) upon request

