



SIL Safety Manual for Echotel® Model 961/962 Loop Version

Functional Safety Manual

Ultrasonic Level Switches



Model 961



Model 962

This manual complements and is intended to be used with the Magnetrol Echotel® Model 961/962 Ultrasonic Single and Dual Point Level Switches Installation and Operating Manual (Bulletin 51-646).

Application

Echotel® Model 961/962 ultrasonic level switches utilize pulsed signal technology to detect high, low, or dual-point level in a broad range of liquid media applications. The advanced self-test technology provides reliability and continuous testing of electronics, transducer, piezo-electric crystals, and electromagnetic noise.

Benefits

The Echotel Model 961/962 ultrasonic level switches provide the following benefits:

- Single- or dual-point liquid level measurement
- Adjustable time-delay for turbulent aerated liquids
- Reliable liquid level measurement independent of changes in media density, conductivity, or temperature
- Two-wire mA current shift
- Integral or remote mount electronics
- Pulsed signal technology
- Extensive FM, CSA, and ATEX explosion proof and intrinsically safe approvals
- Suitable for Safety Integrity Level (SIL) 2 loops



Echotel® Model 961/962 Ultrasonic Level Switches – Loop Version

Table of Contents

1.0 Introduction.....	3	5.6 Configuration.....	9
1.1 Product Description.....	3	5.6.1 Time-delay Potentiometer.....	9
1.2 Theory of Operation.....	3	5.6.2 High/Low DIP Switch.....	9
1.2.1 Transducer Design.....	3	5.6.3 Loop Test Push Button.....	9
1.2.2 Transducer Materials.....	4	5.6.4 Fault Test Push Button.....	10
1.3 Determining Safety Integrity Level (SIL).....	4	5.6.5 22/3.6 DIP Switch.....	10
2.0 Applicable Models.....	5	5.7 Site Acceptance Testing.....	10
3.0 Mean Time To Repair (MTTR).....	5	5.8 Maintenance.....	10
4.0 Supplementary Documentation.....	5	5.8.1 Diagnostics.....	10
5.0 Instructions.....	6	5.8.2 Troubleshooting.....	11
5.1 Systematic Limitations.....	6	6.0 Appendices.....	12
5.1.1 Application Locations.....	6	6.1 SIL Declaration of Conformity.....	12
5.1.2 Operating Temperature.....	6	6.2 FMEDA Report.....	13
5.1.3 Operating Pressure.....	6	6.2.1 FMEDA Report: Management Summary.....	14
5.1.4 Environmental.....	6	6.3 Report - Lifetime of Critical Components.....	15
5.2 Skill Level of Personnel.....	7		
5.3 Necessary Tools.....	7		
5.4 Storage.....	7		
5.5 Installation.....	8		
5.5.1 Hygienic-Specific Installation.....	9		

1.0 Introduction

1.1 Product Description

Echotel® Model 961 and 962 ultrasonic level switches utilize pulsed signal technology to detect high, low, or dual point level in a broad range of liquid media applications.

Model 961 is a single-point level switch. Model 962 is a dual-point switch used as a level controller or to control pumps in an auto-fill or auto-empty mode.

Both Model 961 and 962 switches are suitable for use in Safety Integrity Level (SIL) 2 loops.

1.2 Theory of Operation

Model 961/962 switches utilize ultrasonic energy to detect the presence or absence of liquid in a single or dual point transducer. Ultrasonic contact level technology uses high-frequency sound waves that are easily transmitted across a transducer gap (see Figure 1) in the presence of a liquid media, but are attenuated when the gap is dry.

Model 961/962 switches use an ultrasonic frequency of 2 MHz to perform this liquid level measurement in a wide variety of process media and application conditions.

The transducer uses a pair of piezoelectric crystals that are encapsulated in epoxy at the tip of the transducer. The crystals are made of a ceramic material that vibrates at a given frequency when subjected to an applied voltage. The transmit crystal converts the applied voltage from the electronics into an ultrasonic signal. When liquid is present in the gap, the receive crystal senses the ultrasonic signal from the transmit crystal and converts it back to an electrical signal. This signal is sent to the electronics to indicate the presence of liquid in the transducer gap. When there is no liquid present, the ultrasonic signal is attenuated and is not detected by the receive crystal.

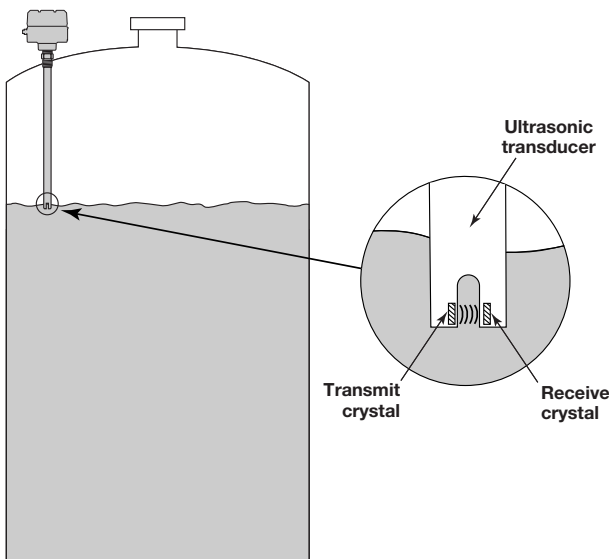

Figure 1
Ultrasonic Signal Transmission
Across Transducer Gap

1.2.1 Transducer Design

Magnetrol's advanced transducer design performs in difficult process conditions. Model 961 has a tip-sensitive transducer with an arched gap increasing its performance in aerated or foamy liquids. Model 962 has a tip-sensitive lower gap and flow-through upper gap permitting separations of 125 inches (318 cm).

1.2.2 Transducer Materials

A broad selection of transducer materials is available for the Model 961/962. Metallic transducers include 316 SS, Hastelloy® C, and Monel®. The 316 SS transducer has a NACE construction option for sour gas service, and can also be built per ASME B31.1 and B31.3 piping codes. Thermoplastic transducers include Kynar® and CPVC. These corrosion resistant plastic transducers feature a stiffening tube that runs the length of the transducer for extra rigidity. Kynar-faced 316 SS flange options are offered with the Kynar transducers.

1.3 Determining Safety Integrity Level (SIL)

Tables 1 and 2 define the criteria for the achievable SIL against the target mode of operation in Demand Mode Operation.

Table 1 shows the relationship between the SIL and the Probability of Failure on Demand Average (PFDavg).

Table 2 can be used to determine the achievable SIL as a function of the Hardware Fault Tolerance (HFT) and the Safe Failure Fraction (SFF) for the complete safety system (Type B—complex components as per IEC 61508 Part 2) of which the level transmitter is one component.

Table 1
SIL vs. PFDavg

Safety Integrity Level (SIL)	Target Average Probability of Failure on Demand (PFDavg)
4	$\geq 10^{-5}$ to $< 10^{-4}$
3	$\geq 10^{-4}$ to $< 10^{-3}$
2	$\geq 10^{-3}$ to $< 10^{-2}$
1	$\geq 10^{-2}$ to $< 10^{-1}$

Table 2
Minimum Hardware Fault Tolerance

SFF	Hardware Fault Tolerance (HFT)		
	0	1	2
None: <60%	Not Allowed	SIL 1	SIL 2
Low: 60% to <90%	SIL 1	SIL 2	SIL 3
Medium: 90% to <99%	SIL 2	SIL 3	
High: $\geq 99\%$	SIL 3		

2.0 Applicable Models

This manual is applicable to the following models of the Echotel ultrasonic level switches with current shift output:

- Model 961 Single-Point Level Switches
- Model 962 Dual-Point Level Switches

3.0 Mean Time To Repair (MTTR)

SIL determinations are based on a number of factors including the Mean Time To Repair (MTTR). The analysis for the Echotel Model 961/962 ultrasonic level switch is based on a MTTR of 24 hours.

4.0 Supplementary Documentation

Refer to the following documents as supplements to this Echotel Model 961/962 SIL Safety Manual:

- *Echotel Model 961/962 Ultrasonic Level Switches Installation and Operating Manual* (Bulletin 51-646)
- Failure Modes, Effects and Diagnostics Analysis (FMEDA)
exida Report No.: MAG 16/08-078 R001
Version V1, Revision R3, December 20, 2016

NOTE: The Failure Modes, Effects, and Diagnostic Analysis (FMEDA) report can be found in the Downloads tab of the Echotel 961/962 site page on magnetrol.com.

5.0 Instructions

5.1 Systematic Limitations

The following application and environmental limitations must be observed to avoid systematic failures.

5.1.1 Application Locations

The Model 961/962 ultrasonic level switch should be located for easy access for service, configuration, and monitoring. There should be sufficient headroom to allow installation and removal of the unit. Special precautions should be made to prevent exposure to corrosive atmosphere, excessive vibration, shock, or physical damage.

5.1.2 Operating Temperature

The ambient temperature range for the 961/962 electronics is -40 to +160 °F (-40 to + 70 °C). The operating temperature for the transducer is dependent on transducer material (see Table 3).

Table 3
9A1/9M1 Transducer Operating Temperatures

316 Stainless Steel, Hastelloy C, and Monel	-40 to +325 °F (-40 to +163 °C)
Kynar	-40 to +250 °F (-40 to +121 °C)
CPVC	-40 to +180 °F (-40 to +82 °C)

5.1.3 Operating Pressure

Maximum operating pressures are dependent on the transducer material. Refer to Section 3.4 in the *Echotel Model 961/962 Ultrasonic Level Switches Installation and Operating Manual* (Bulletin 51-646).

5.1.4 Environmental

See Section 3.4 of the *Echotel Model 961/962 Ultrasonic Level Switches Installation and Operating Manual* (Bulletin 51-646) for environmental limitations.

5.2 Skill Level of Personnel

Personnel following the procedures of this safety manual should have technical expertise equal to or greater than that of a qualified instrument technician.

5.3 Necessary Tools

No special equipment or tools are required to install Echotel Model 961/962 ultrasonic level switch. The following items are recommended:

- Wrenches, flange gaskets, and flange bolting appropriate for process connection(s)
- Screwdrivers and assorted tools for making conduit and electrical connections
- Digital multimeter or DVM for troubleshooting

5.4 Storage

Model 961/962 should be stored in its original shipping box and not be subjected to temperatures outside the storage temperature range -40 to +160 °F (-40 to +70 °C), as shown in Section 3.1 of the *Echotel Model 961/962 Ultrasonic Level Switches Installation and Operating Manual* (Bulletin 51-646).

5.5 Installation

The Model 961 single point switch may be used for high or low level alarm, overflow protection, or seal pot level and pump protection. Model 961 can be mounted vertically or horizontally in vessels, bridles, or pipes.

The Model 962 dual point switch may be used to measure high/low, high/high, or low/low levels. It can be used as a level controller or to control pumps in an auto-fill or auto-empty mode. Model 962 must be top mounted.

Refer Figures 2–5 to the *Echotel Model 961/962 Ultrasonic Switches Installation and Operating Manual* (Bulletin 51.646) for the proper installation instructions.

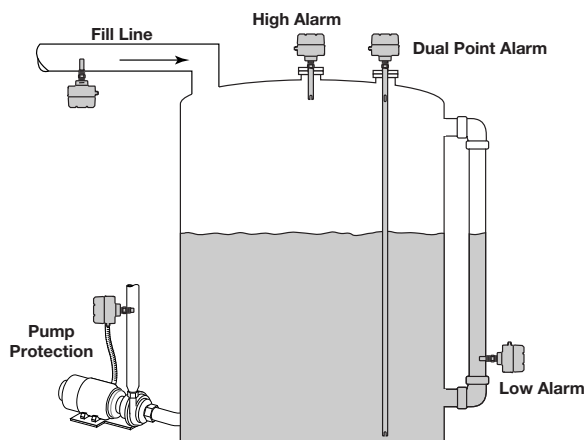

Figure 2
Typical Mounting Orientations

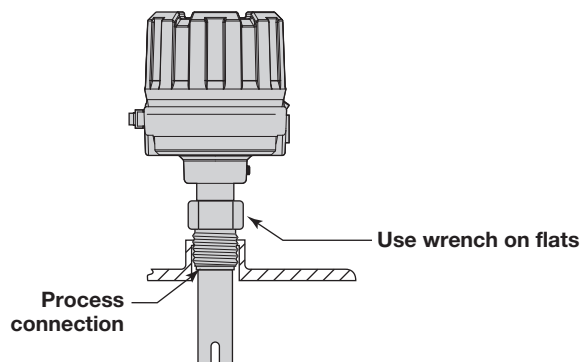

Figure 3
Vertical Mounting

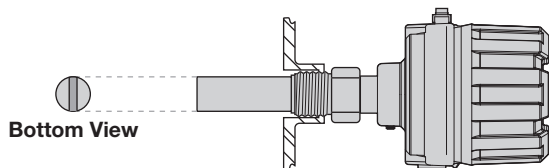

Figure 4
Horizontal Mounting

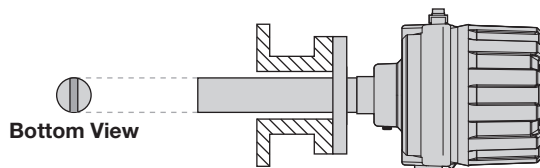

Figure 5
Nozzle Mounting

5.5.1 Hygienic-Specific Installation

The hygienic version of the Model 961 is available with a deep-drawn 304 stainless steel housing. A variety of hygienic process connections are offered for use in food and beverage, pharmaceutical, and biotechnology applications. These hygienic transducers have 3-A (Authorization #596), EHEDG certification (per TNO Report # V4772/01) and a 20 Ra finish providing a uniform and ultra-smooth surface that inhibits microbial growth. Electron beam welding technology is utilized to facilitate a crevice-free surface inside the transducer tip. This allows these transducers to be used in a wide variety of hygienic applications where CIP (clean-in-place) is used to remove any contamination from the transducer surface.

5.6 Configuration

Refer to Section 2.5 in the *Echotel Model 961/962 Ultrasonic Level Switches Installation and Operating Manual* (Bulletin 51-646) for complete configuration instructions.

5.6.1 Time-Delay Potentiometer

The time-delay potentiometer is used in applications where turbulence or splashing may cause false level alarm. The response time can be adjusted from factory-set standard of 0.5 seconds to a maximum of 10 seconds. The time-delay potentiometer is an option for both Model 961 and Model 962.

5.6.2 High/Low DIP Switch

The Hi/Lo DIP switch is used to select whether the switch is used as a high-level fail-safe or a low-level fail-safe switch. See Section 2.5 of the *Echotel Model 961/962 Ultrasonic Level Switches Installation and Operating Manual* (Bulletin 51-646) for high/low DIP switch configuration tables.

5.6.3 Loop Test Push Button

The loop test push button is used to manually test the loop current output. For Model 961, pressing the loop test push button reverses the output from 8 mA to 16 mA or from 16 mA to 8 mA. For Model 962, pressing the loop test push button changes the output from 8 mA to 12 mA, 12 mA to 16 mA, or 16 mA to 8 mA.

5.6.4 Fault Test Push Button

The fault test push button is used to manually change the mA values to that selected at the 22/3.6 DIP switch. Pressing this push button for two seconds simulates a circuit test failure. The output goes to the selected fault current of either 22 or 3.6 mA, and all three LEDs go dark. The fault test push button is an option on both Model 961 and Model 962.

5.6.5 22/3.6 DIP Switch

The 22/3.6 switch is used to produce a 22 mA or 3.6 mA output when the unit detects a fault. The 22/3.6 switch is on both the Model 961 and Model 962.

5.7 Site Acceptance Testing

Complete a site acceptance test to ensure proper operation after installation and configuration. Results of site acceptance testing should be recorded for future reference.

5.8 Maintenance

- Report all failures to Magnetrol.
- Firmware can only be upgraded by factory personnel.

5.8.1 Diagnostics

Model 961/962 has a unique diagnostics feature to assist in troubleshooting should a failure occur. A microprocessor in the electronics continuously monitors all self-test data. Should a fault occur, the microprocessor can determine whether the malfunction is due to the electronics, transducer, piezoelectric crystals, or the presence of environmental noise.

Table 4 shows the push buttons and LEDs used for each version of the 961/962 for diagnostic troubleshooting.

Table 4
Diagnostic Push Buttons and LED Indications

Electronics Version	Push Button	LED
961 with current shift	LOOP TEST	FAULT
962 with current shift	LOOP TEST	16 mA

5.8.2 Troubleshooting

Model 961/962 has a diagnostic push button and Fault LED used to assist in troubleshooting the switch (see Table 5).

Refer to Section 3.7 of the *Echotel Model 961/962 Ultrasonic Level Switches Installation and Operating Manual* (Bulletin 51-646) for troubleshooting device errors.

Table 5
Troubleshooting Faults and Corrective Actions

Flashes	Fault	Action
1 flash	Indicates a problem with either the transducer, piezoelectric crystals, or the interconnection wiring.	Check wiring inside the housing to make sure that all wires are secure in their respective terminal blocks. Make sure that all the terminal block screws are fully tightened. If all wires are secure then contact the factory. Replace transducer if needed. Refer to Section 3.8 of the <i>Installation and Operating Manual</i> for proper replacement part numbers.
2 flashes	Indicates a problem with one of the electronics boards.	Contact the factory for a replacement electronics module. Refer Section 3.8 of the <i>Installation and Operating Manual</i> for spare electronics modules part numbers.
3 flashes	Indicates excessive levels of environmental noise.	Check if any source may be causing the interference, such as VFD (variable frequency drive), radiated electrical interference (two-way radio transceiver) or mechanical vibration from nearby source.

6.0 Appendices

6.1 SIL Declaration of Conformity

Functional safety according to IEC 61508.

Magnetrol International, Incorporated, 705 Enterprise Street, Aurora, Illinois 60504 declares as the manufacturer, that the level switches:

Echotel® Model 961/962 Ultrasonic Single and Dual Point Level Switches

are suitable for use in safety instrumented systems according to IEC 61508, if the safety instructions and following parameters are observed:

FIT = Failure in Time (1×10^{-9} failures per hour)

Product	Model 961 Dry is Safe	Model 961 Wet is Safe	Model 962 Dry is Safe	Model 962 Wet is Safe
SIL	2	2	2	2
Proof Test Interval	1 Year	1 Year	1 Year	1 Year
Device Type	B	B	B	B
SFF	96.5%	90.2%	98.0%	90.5%
PFD_{avg}	3.71E-04	5.04E-04	1.65E-04	4.66E-04
λ_{sd}	145 FIT	18 FIT	335 FIT	36 FIT
λ_{su}	38 FIT	20 FIT	64 FIT	26 FIT
λ_{dd}	41 FIT	168 FIT	34 FIT	332 FIT
λ_{du}	10 FIT	27 FIT	10 FIT	47 FIT



Failure Modes, Effects and Diagnostic Analysis

Project:
ECHOTEL 961/962 Ultrasonic Single and Dual Point Level Switches

Company:
Magnetrol International, Inc.
Aurora, IL
USA

Contract Number: Q16/08-078
Report No.: MAG 16/08-078 R001
Version V1, Revision R3, December 20, 2016
Rudolf Chalupa

The document was prepared using best effort. The authors make no warranty of any kind and shall not be liable in any event for incidental or consequential damages in connection with the application of the document.
© All rights reserved.



Management Summary

This report summarizes the results of the hardware assessment in the form of a Failure Modes, Effects, and Diagnostic Analysis (FMEDA) of the ECHOTEL 961/962 Ultrasonic Single and Dual Point Level Switches, hardware revision and software revision per Section 2.5.1. A Failure Modes, Effects, and Diagnostic Analysis is one of the steps to be taken to achieve functional safety certification per IEC 61508 of a device. From the FMEDA, failure rates are determined. The FMEDA that is described in this report concerns only the hardware of the 961/962. For full functional safety certification purposes all requirements of IEC 61508 must be considered.

ECHOTEL 961/962 Ultrasonic Single and Dual Point Level Switches utilize pulsed signal technology to detect high, low, or dual point level in a broad range of liquid media applications. Model 961 is a single point level switch. Model 962 is a dual point switch used as a level controller or to control pumps in an auto-fill or auto-empty mode.

Table 1 gives an overview of the different versions that were considered in the FMEDA of the 961/962.

Table 1 Version Overview

961 Dry Is Safe	Single Point Level Switch, Reported Dry Condition Is Safe
961 Wet Is Safe	Single Point Level Switch, Reported Wet Condition Is Safe
962 Dry Is Safe	Dual Point Level Switch, Reported Dry Condition Is Safe
962 Wet Is Safe	Dual Point Level Switch, Reported Wet Condition Is Safe

The 961/962 is classified as a Type B¹ element according to IEC 61508, having a hardware fault tolerance of 0.

The analysis shows that the 961/962 has a Safe Failure Fraction between 90% and 99% (assuming that the logic solver is programmed to detect over-scale and under-scale currents) and therefore meets hardware architectural constraints for up to SIL 2 as a single device.

Based on the assumptions listed in 4.3, the failure rates for the 961/962 are listed in section 4.5.

These failure rates are valid for the useful lifetime of the product, see Appendix A.

The failure rates listed in this report are based on over 250 billion unit operating hours of process industry field failure data. The failure rate predictions reflect realistic failures and include site specific failures due to human events for the specified Site Safety Index (SSI), see section 4.2.2.

A user of the 961/962 can utilize these failure rates in a probabilistic model of a safety instrumented function (SIF) to determine suitability in part for safety instrumented system (SIS) usage in a particular safety integrity level (SIL).

¹ Type B element: "Complex" element (using micro controllers or programmable logic); for details see 7.4.4.1.3 of IEC 61508-2, ed2, 2010.

6.3 Report - Lifetime of Critical Components

According to Section 7.4 of IEC 61508-2, a useful lifetime, based on experience, should be assumed.

Although a constant failure rate is assumed by the probabilistic estimation method, this only applies provided that the useful lifetime of components is not exceeded. Beyond their useful lifetime, the result of the probabilistic calculation method is therefore meaningless, as the probability of failure significantly increases with time. The useful lifetime is highly dependent on the subsystem itself and its operating conditions.

This assumption of a constant failure rate is based on the bathtub curve. Therefore it is obvious that the PFDavg calculation is only valid for components that have this constant domain and that the validity of the calculation is limited to the useful lifetime of each component.

As there are no electrolytic capacitors used, there are no electrical components that limit the useful lifetime of the system.

Based on general field failure data, a useful life period of approximately 50 years is expected for the Echotel Model 961/962 Ultrasonic Level Switches.

When plant experience indicates a shorter useful lifetime than indicated, the number based on plant experience should be used.

References

- IEC 61508 Edition 2.0.2010
“Functional Safety of Electrical/Electronic/
Programmable Electronic Safety Related Systems”
- ANSI/ISA-84.00.01-2004 Part 1 (IEC 61511-1Mod)
“Functional Safety: Safety Instrumented Systems for
the Process Industry Sector–Part 1 Hardware and
Software Requirements”
- ANSI/ISA-84.00.01-2004 Part 2 (IEC 61511-2Mod)
“Functional Safety: Safety Instrumented Systems for
the Process Industry Sector–Part 2 Guidelines for the
Application of ANSI/ISA84.00.01-2004 Part 1 (IEC
61511-1 Mod)–Informative”
- ANSI/ISA-84.00.01-2004 Part 3 (IEC 61511-3Mod)
“Functional Safety: Safety Instrumented Systems for the
Process Industry Sector–Part 3 Guidance for the
Determination of the Required Safety Integrity Levels–
Informative”
- ANSI/ISA-TR84.00.04 Part 1 (IEC 61511 Mod)
“Guideline on the Implementation of ANSI/ISA-
84.00.01-2004”

ASSURED QUALITY & SERVICE COST LESS

Service Policy

Owners of Magnetrol controls may request the return of a control or any part of a control for complete rebuilding or replacement. They will be rebuilt or replaced promptly. Controls returned under our service policy must be returned by prepaid transportation. Magnetrol will repair or replace the control at no cost to the purchaser (or owner) other than transportation if:

1. Returned within the warranty period; and
2. The factory inspection finds the cause of the claim to be covered under the warranty.

If the trouble is the result of conditions beyond our control; or, is NOT covered by the warranty, there will be charges for labor and the parts required to rebuild or replace the equipment.

In some cases it may be expedient to ship replacement parts; or, in extreme cases a complete new control, to replace the original equipment before it is returned. If this is desired, notify the factory of both the model and serial numbers of the control to be replaced. In such cases, credit for the materials returned will be determined on the basis of the applicability of our warranty.

No claims for misapplication, labor, direct or consequential damage will be allowed.

Return Material Procedure

So that we may efficiently process any materials that are returned, it is essential that a “Return Material Authorization” (RMA) number be obtained from the factory prior to the material’s return. This is available through Magnetrol’s local representative or by contacting the factory. Please supply the following information:

1. Company Name
2. Description of Material
3. Serial Number
4. Reason for Return
5. Application

Any unit that was used in a process must be properly cleaned in accordance with OSHA standards, before it is returned to the factory.

A Material Safety Data Sheet (MSDS) must accompany material that was used in any media.

All shipments returned to the factory must be by prepaid transportation.

All replacements will be shipped F.O.B. factory.



705 Enterprise Street • Aurora, Illinois 60504-8149 • 630-969-4000
info@magnetrol.com • www.magnetrol.com

Copyright © 2017 Magnetrol International, Incorporated

Magnetrol, Magnetrol logotype, and Echotel are registered trademarks of Magnetrol International.
Hastelloy® is a registered trademark of HAYNES INTERNATIONAL, INC. (DELAWARE CORPORATION).
Monel® is a registered trademark of the INCO family of companies.
Kynar® is a registered trademark of Elf Atochem North America, Inc.

BULLETIN: 51-650.1
EFFECTIVE: April 2017
SUPERSEDES: July 2010