

Smith Meter® Rotary Vane PD Meters
Single and Double Case PD Meters
 Installation / Operation / Maintenance Manual

Bulletin MN01011 Issue/Rev 1.0 (6/17)

Models

Singles-Case Meters

SC-13, 13DI
 SD-30, 30DI
 SD3-S1
 ST-40, 75, 160
 SE & VE-42
 SF & VF-60

Double-Case Meters

C2-S1 Through S7
 E3 & E4-S1 Through S7, A1, A3
 F4-S1 Through S7, A1, A3, V1
 G6-S1 Through S7, A1, A3, V1
 H8-S1 Through S7
 JA & JB10-S1 Through S7
 K12-S1 Through S7
 M16-S1 Through S7

**Non-Ferrous Aircraft
 Fueling Meters**

SD or ASD-3-NF
 SD or ASD-3V-NF
 SD or ASD-4-NF
 SD or ASD-4V-NF
 SF or ASF-4-NF
 SF or ASF-4V-NF
 SF or ASF-6-NF
 SF or ASF-6V-NF
 SG or ASG-6-NF
 SG or ASG-6V-NF



Caution

Read instructions carefully before attempting to operate. Each meter is thoroughly tested before leaving the factory. TechnipFMC Measurement Solutions, Inc. cannot accept claims for damage caused by air, line contamination, or pressure shock waves during start-up.

Contents

Section 1 – Principle of Operation	Page 2
Section 2 – Installation	Page 3
Section 3 – Operation	Page 4
Start-Up	Page 4
General Operating Information	Page 4
Section 4 – Maintenance	Page 5
Section 5 – Reversing Meter Rotation	Page 6

Section 1 – Principle of Operation

These meters are of the rotary positive displacement type. The accurately-machined housing contains a rotor which revolves on ball bearings and carries evenly-spaced blades. As liquid flows through the meter, the rotor and blades (vanes) revolve about a fixed cam causing the blades to move outward. The successive movement of the blades forms a measuring chamber of precise volume between two of the blades, the rotor, the housing, the bottom, and the top covers. A continuous series of these closed chambers is produced for each rotor revolution. Neither blades nor rotor contact the stationary walls of the measuring chamber.

One of the outstanding features of the Smith meter principle is that the flow is literally undisturbed while it is being metered. Energy is not wasted by unnecessary hydraulic bending of the liquid.

Figure 1

Unmeasured liquid (shaded area) is shown entering meter. Rotor and vanes are turning clockwise. Vanes A and D are fully extended forming the measuring chamber; Vanes B and C are retracted.

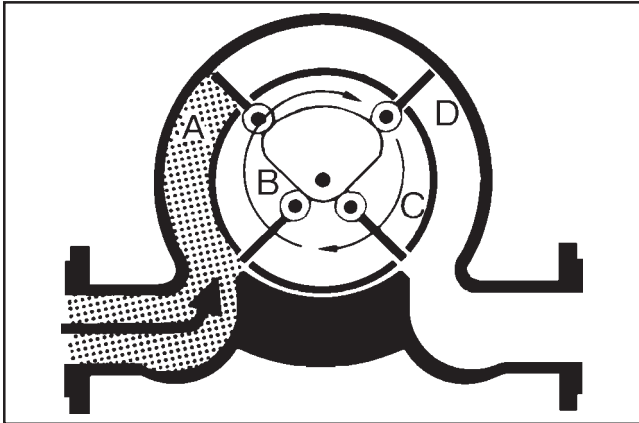

Figure 2

The rotor and vanes have made one-eighth revolution. Vane A is fully extended; Vane B is partially extended; Vane C is fully retracted; Vane D is partially retracted.

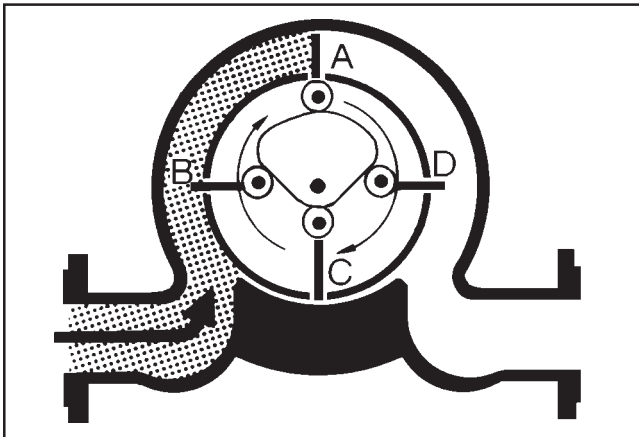

Figure 3

A quarter revolution has been made. Vane A is still extended and Vane B is now fully extended. An exact and known volume of new liquid is now in the measuring chamber.

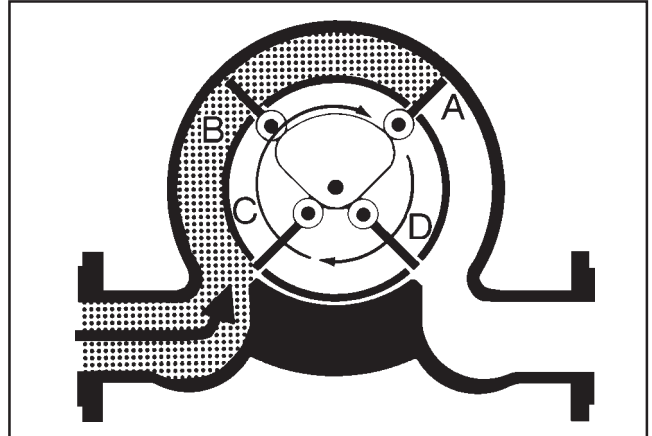
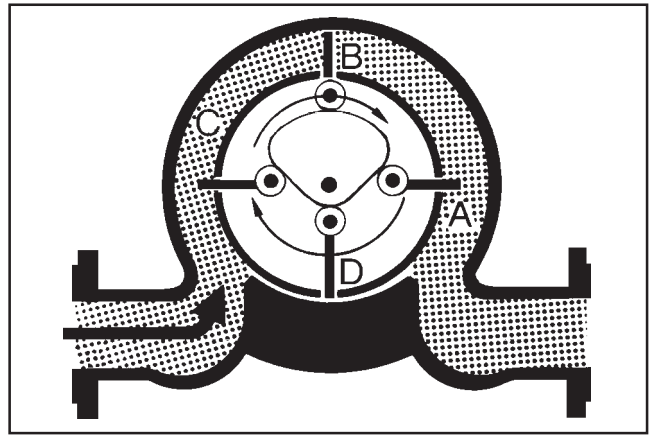

Figure 4

One eighth revolution later, the measured liquid is moving out of the meter. A second measuring chamber is being created between Vanes B and C. Vane A has begun to retract and Vane C is beginning to extend.

In three-eighths of a revolution, one measured segment of fluid has been passed and a second segment is being created. This cycle is repeated as long as liquid flows.



Section 2 – Installation

1. The meter and its accessories are precision instruments and should be treated accordingly. Prior to installation, the equipment should be protected from adverse weather conditions and accidental abuse.
2. The installation should provide protection from sand, dust, rain, sleet, etc. where extreme adverse weather conditions are encountered.
3. The meter should be mounted on a suitable base or platform so it will not be supported by the piping.
Meters are generally designed to be installed in a horizontal line with the mounting feet supported in a plane parallel with the ground or floor. Meters with the letter "V" in the model number, are designed to be installed in a vertical line with mounting feet supported in a plane parallel with the ground or floor. Orientation other than that for which the meter is designed is not recommended.
Dimensional outline drawings showing size and location of anchor holes are available for all meters.
4. Install the meter so that it cannot be accidentally drained of product; however, it is advisable to drain the meter of water and sediment periodically.
When installing the meter, be sure the drain plug is accessible.
5. Piping must not produce an undue strain on the meter.
6. Protect the meter and system against the effects of thermal expansion with a relief valve.
7. Where necessary, a deaerator or air eliminator should be installed to keep air and vapor out of the meter.
8. All piping should be internally cleaned before the meter is put into operation.
Rust, dirt, welding shot, and other foreign material should be removed completely.
Remove the inner mechanism in double-case meters or the rotor and blade assembly in single-case meters and flush the lines to prevent damage to the metering element.
The meter should be protected by at least a 4-mesh strainer.
All non-ferrous meters must be downstream of at least a 5-micron filter.
9. Where necessary, a flow-limiting valve should be installed downstream of the meter to protect it from excessive flow rates.
10. Remove the inner mechanism if the system is to be pressure-tested with water or if debris is to be flushed from the system.
11. Do not calibrate with water or allow water to stand in the meter.
Flush the meter with a light lubricating oil if it is left idle or stored.
12. Unless otherwise specified, meters normally flow from left to right when viewed from the flanged side of the housing.
Most meters can be changed to flow from right to left. Consult factory.
13. A counter may be located in any one of four 90° positions. Large numeral counters may be located in any of eight 45° positions.

WARNING!
Thermal Pressure

Thermal expansion of liquid in this equipment can cause high pressure damage. A Thermal Pressure Relief Valve may be necessary in the system.

Start-Up Procedure

Use precaution when starting-up a PD meter in a new line that is not purged of air and packed with fluid. Never start a meter by haphazardly opening flow control valves. Due to the nature of their design and the close running clearances between moving parts, all PD meters risk being damaged if started in this manner. Primarily, a pressure differential can form across the rotor walls due to air on the inside and line pressure outside the rotor. This condition causes the rotor slots to collapse and pinch the blades, which in turn causes the paddle to crack and separate at the yoke. Secondly, air being purged by upstream product can spin the measuring element to excessive speeds and should liquid suddenly hit the measuring element while it is spinning a hydraulic brake takes effect causing a line shock which could result in a fractured rotor, a broken blade or a combination of both. Therefore, air and gas must be removed from the meter internals prior to normal operation. Complete venting can be accomplished by performing the following start-up procedures.

1. When starting double case PD meters, first remove the pipe plug located in the outer housing cover and use the pipe tap to install an air bleed system that can be regulated by a control valve.

Note that, in the event of starting single case meters, an air vent option is not available. Therefore, air trapped inside a single case meter must be gradually purged downstream as the flow rate is slowly increased.

2. With the downstream valve completely closed and only gravity pressure being exerted, **slowly open the upstream valve** until liquid begins to flow into the meter. Open the bleed valve and vent until no air or gas is apparent. The meter housing vents much faster than the rotor.
3. **Close the upstream valve** prior to starting pumps and repeat step 2. Venting can take several minutes if the pressure is low and the liquid viscosity is high.
4. **Slowly open the downstream valve** until flow begins. Notice that more air or gas will be vented. Continue to operate at this very low rate until venting is complete.
5. Close the bleed valve and **fully open the downstream valve**. The upstream valve can now be slowly opened to establish full flow.

This procedure must be followed each time the meter is drained.

General Operating Information

1. Inlet and outlet valves should be operated slowly to avoid line shock. Abrupt closure can create forces in excess of normal line pressure. This could result in damage to the meter and other equipment.

2. Do not manually operate a reset-type counter when the meter is operating.
3. The securing pin in a ticket printer head must be in the down or locked position when the meter is operating.
4. Meters equipped with manual calibrators or ATC's can only operate in one direction.
5. Calibration adjustment has been made at the factory for zero error at maximum nameplate capacity on 2 cP solvent. Due to variations in operating conditions (e.g., actual liquid, pressure, and flow rate), the meter should be proved after installation. See API referenced standards.
6. Manual meter calibration is accomplished by adjusting the calibrator dial. Calibration may be changed in increments of .0005 (1/20th of 1 percent). The dial is marked \pm and is concealed under a wire-sealed cover on the calibrator adjuster located on the top dome of the meter. The amount of product indicated by the meter increases when the calibrating dial is turned in a counter-clockwise direction and diminishes if the dial is turned in a clockwise direction. On meters with ATC (Automatic Temperature Compensation), each notch provides a change equal to the Coefficient of Expansion per degree F. For example, an ATC Calibrator for 38° API would provide .00048 per notch as 38° API has a Coefficient of Expansion of .00048/°F. If an ATG (Automatic Temperature Gravity Compensator) is installed in the meter stack-up, calibration adjustment is made using the screw adjustment located under the small wire-sealed cover labeled "meter adjustment." A clockwise direction decreases registration.
7. To obtain maximum service from Smith meters, it is suggested that detailed records be maintained.

Data such as model, serial number, operating rate, type of product, meter clearances, totalizer readings, meter factor, and other pertinent information should be recorded. Such information is an excellent guide in scheduling a preventive maintenance program.

Reference Publications

American Petroleum Institute
2101 L Street, Northwest
Washington, DC 20037

Manual of Petroleum Measurement Standards.

API Chapter 4 – Proving Systems.

API Chapter 5, Section 5.2 – Measurement of Liquid Hydrocarbons by Displacement Meter Systems.

API Chapter 12, Section 2 Field Manual – Instructions for Calculating Liquid Petroleum Quantities Measured by Turbine or Displacement Meters.

Section 4 – Maintenance

1. If your meter has a calibrator, it requires lubrication with light oil (SAE-10). Initially, apply it after approximately five hours of operation and then about twice yearly. (See oil cup – Figure 5).

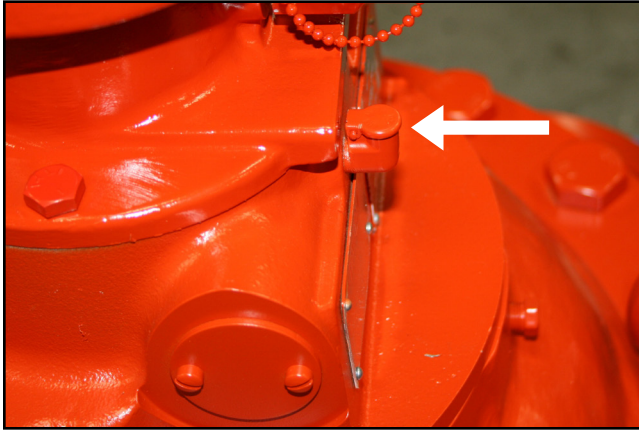

Figure 5 – Oil Cup (E3)

2. PD meters may be used in petroleum applications where the corrosion/erosion is normally minimal. PD meter pressure containing housings are designed with an adequate allowance for petroleum applications. Consult the factory for other applications or for actual material allowances.

High Pressure Packing Gland Maintenance (Models C2 Through M16 – S1, S3, S5, S6, and S7)

Glycerine solution is used as a sealant and lubricant in this type of packing gland. The gland should be serviced on an interval determined by experience, however, the period between injections is recommended to not exceed 60 days.

Ambient Temperature	Lubricant
-4°F to 300°F (-20°C to 150°C)	Glycerine Solution

If the meter has been idle for a period of time, prior to startup, inject the packing gland with 1 oz. of Glycerine solution.

The lubricant injection volume is recommended to be 1 fluid oz. injected through the lubricant (Zerck) fitting (Figure 6 and Figure 7). The packing gland design and reservoir overflow into the meter ensures that the packing gland cannot be overfilled.

Note: Lubricant grease should never be used in the packing gland.

Reference Literature:

- [PO01042](#) Packing Gland Parts List
- [PO0A002](#) Lubricants and Sealants Parts List
- [PO0A001](#) Tools Parts List

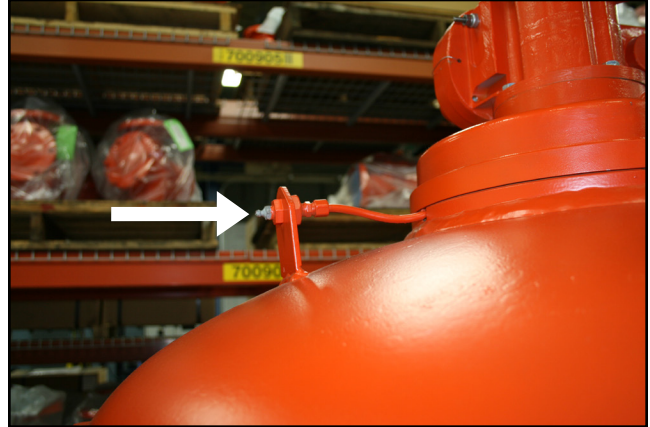

Figure 6 – Lubrication Fitting (M16)



Figure 7 – Lubrication Fitting (F4)

Section 5 – Reversing Meter Rotation

The clutch-type calibrator and most Smith Meter accessories must be driven in a counter-clockwise rotation as viewed from the top. Since the meter rotor will revolve in either direction, flow may be reversed and a clockwise (CW), right-hand meter may be changed to a counter-clockwise (CCW), left-hand meter and vice versa.

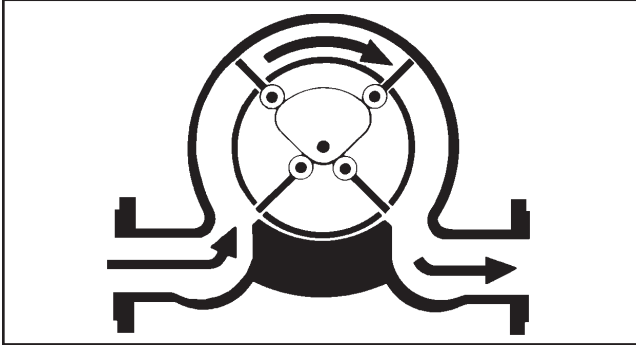

Figure 8

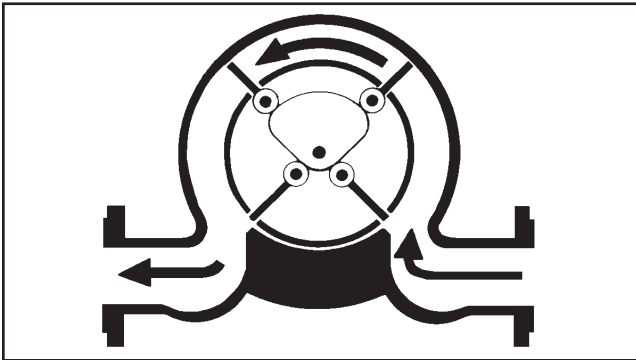

Figure 9

Unless otherwise specified, standard meters flow from left to right, CW rotation (see Figure 8). To change flow from right to left, CCW rotation (see Figure 9), proceed as follows:

- Remove counter(s) and calibrator from top of meter.

Meters 3"-8"; Single-Case; S1, S2, V1, and A1 Double-Case; and Non-Ferrous Meters

Note: To reverse rotation, the jackshaft pinion gear must have the same number of teeth as the lower gear of the intermediate gear pinion. For a few special gear trains, these gears are not the same ratio, and to reverse rotation, additional gears are required. Consult factory for assistance.

1. Reverse rotation by removing and reversing the location of the jackshaft pinion gear and the intermediate gear pinion as noted in Figure 11.
 - a. The calibrator drive gear remains in its original position.
 - b. After switching gears, it will be noted that the jackshaft pinion no longer serves any purpose and may be removed if desired.
 - c. Replace washers and cotter pins.

Meters 2"-8", A3, S3-S7 Double-Case and All 10"-16" Meters

The gear train is located on the inside of the outer cover. Refer to respective service manual for specific instructions on removing the cover and then follow steps outlined above.

Section 5 – Reversing Meter Rotation (continued)

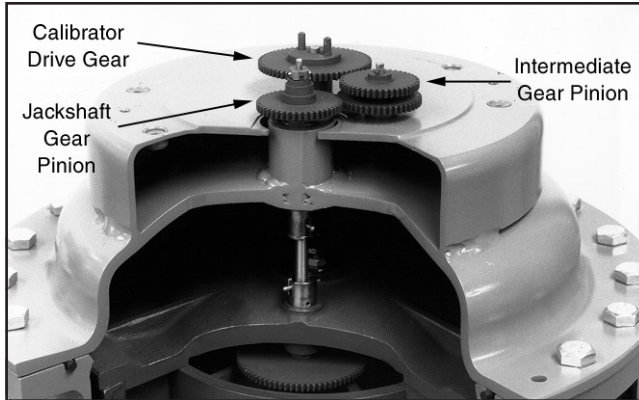

Figure 10 – Model E3-S1, Clockwise Rotation

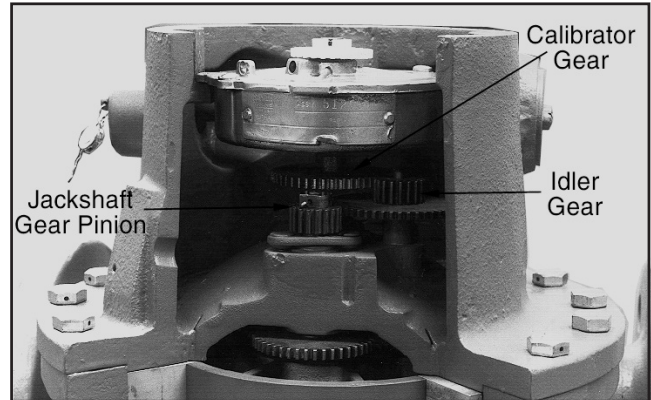

Figure 12 – Meters 2" Clockwise Rotation

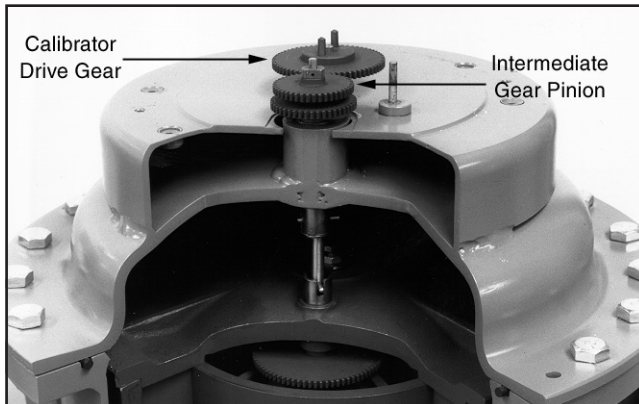

Figure 11 – Model E3-S1, Counter-Clockwise Rotation

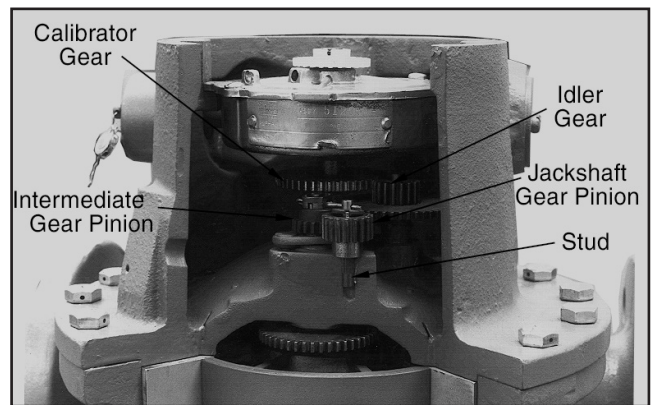

Figure 13 – Meters 2" SC-13, Counter-Clockwise Rotation

Meters 2" SC-13

- Reverse, CCW, rotation requires a reversing kit consisting of an intermediate gear, stud, washer, and cotter pin. To change rotation to CCW:
 1. Remove the jackshaft pinion gear;
 2. install the new stud in the hole provided on the cover;
 3. install the jackshaft pinion gear on the new stud and the intermediate gear on the jackshaft.
 - a. The calibrator drive gear remains in its original position.
 - b. For CW rotation, the procedure is reversed and the intermediate gear no longer serves any purpose and may be removed.
 - c. Replace washers and cotter pins.
2. Replace calibrator and counter(s).
 - a. Be sure calibrator gear and meter gear mesh properly before tightening adapter screws.

Technical Support

Contact Information:

Field Service Response Center

24/7 Technical Support/Schedule

a Technician: 1-844-798-3819

System Installation Supervision,

Start-Up, Training, and

Commissioning Services Available

Revisions included in MN01011 Issue/Rev. 1.0 (6/17):

Reference to Silicone oil removed and replaced with glycerine solution.

The specifications contained herein are subject to change without notice and any user of said specifications should verify from the manufacturer that the specifications are currently in effect. Otherwise, the manufacturer assumes no responsibility for the use of specifications which may have been changed and are no longer in effect.

Contact information is subject to change. For the most current contact information, visit our website at TechnipFMC.com and click on the "Contact Us" link.

TechnipFMC.com

© TechnipFMC 2017 All rights reserved. MN01011 Issue/Rev. 1.0 (6/17)

TechnipFMC
FMC Technologies
Measurement Solutions, Inc.
500 North Sam Houston Parkway West,
Suite 100
Houston, Texas 77067 USA
P:+1 281.260.2190

USA Operation
1602 Wagner Avenue
Erie, Pennsylvania 16510 USA
P:+1 814.898.5000

Germany Operation
Smith Meter GmbH
Regentstrasse 1
25474 Ellerbek, Germany
P:+49 4101 304.0