

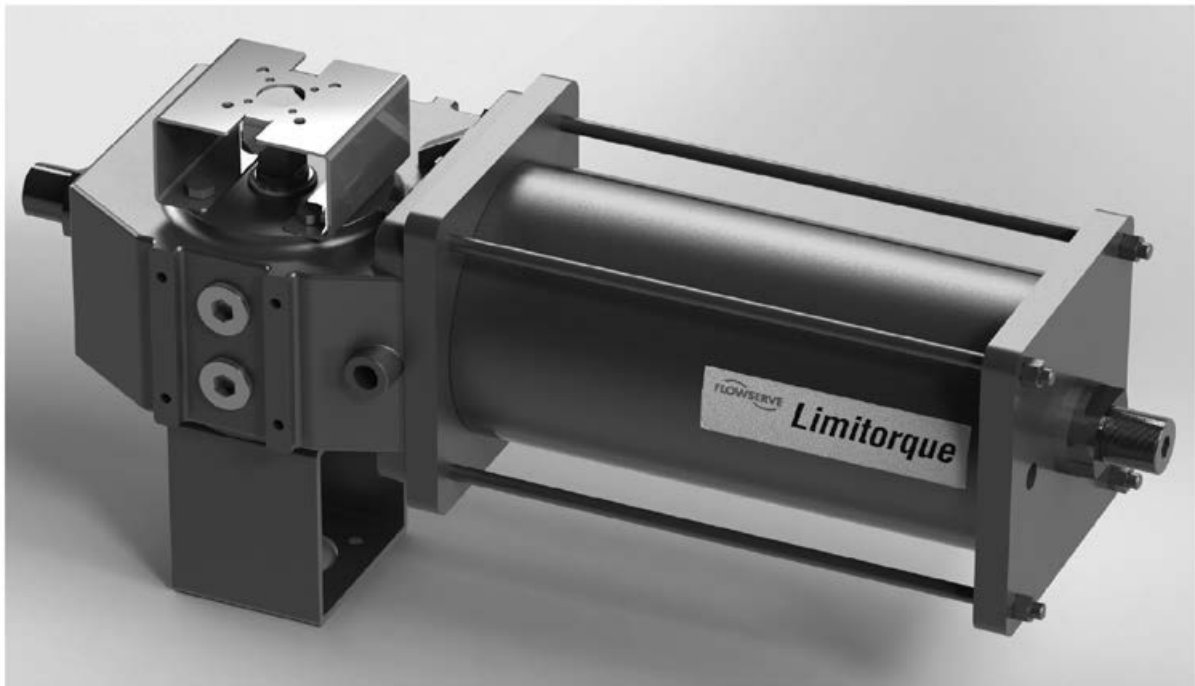

TECHNICAL BULLETIN

LPC Compact Actuator Series

FCD LFENTB0002-01-A4-(5/16)



Contents

- LPC Series Compact Actuator Specifications4
- Actuator Selection Table6
- LPC Torque and Pressure Table.....6
- Actuator Selection Guidance.....6
 - 1 Scope.....6
 - 2 General Definitions/Terms Used6
 - 3 Inputs for Sizing Pneumatic Scotch Yoke Actuators.....7
 - 4 LPC Manual Overrides9
 - 5 Fail Open/Fail Close and Double Acting Configurations10
 - 6 Performance Data11
 - 7 Dimensions.....11
 - 8 Disclaimer11
- Dimensional Data and Weights – LPC Single Acting12
- Dimensional Data and Weights – LPC Double Acting16
- Dimensional Data and Weights – LPC Single Acting With JL
Manual Override18
- Dimensional Data and Weights – LPC Double Acting With JL
Manual Override22
- Mounting Interface Coupling Dimensions and Standard NAMUR
VDE/VDI 3845 Kit Details.....24

Tables

Table 1: LPC Single Acting – Dimensional, Weight and Volume Tables..... 13–15

Table 2: LPC Double Acting – Dimensional, Weight and Volume Tables.....17

Table 3: LPC Single Acting w/ JL Manual Override – Dimensional, Weight and Volume Tables..... 19–21

Table 4: LPC Double Acting w/ JL Manual Override – Dimensional, Weight and Volume Tables.....23

Figures

Figure 1: Actuator OPEN (by instr. air) Torque Curve: Single Acting Spring Return – Fail Close (CW).....7

Figure 2: Actuator CLOSE (by spring) Torque Curve: Single Acting Spring Return – Fail Close (CW).....8

Figure 3: LPC Double Acting Actuator With JL Jackscrew Manual Override.....9

Figure 4: LPC Single Acting Actuator With JL Jackscrew Manual Override.....9

Figure 5: Single Acting Actuator Configuration: Fail Close – Fail Clockwise.....10

Figure 6: Single Acting Actuator Configuration: Fail Open – Fail Counterclockwise.....10

Figure 7: Double Acting Actuator Configuration – Close Position.....10

Figure 8: Double Acting Actuator Configuration – Open Position.....11

Figure 9: Dimensional Data – Single Acting – Sym/Cant – Fail Close.....12

Figure 10: Dimensional Data – Single Acting – Sym/Cant – Fail Open.....12

Figure 11: Dimensional Data – Double Acting – Sym/Cant.....16

Figure 12: Dimensional Data – Single Acting – Sym/Cant – Fail Close With JL Manual Override.....18

Figure 13: Dimensional Data – Single Acting – Sym/Cant – Fail Open With JL Manual Override...18

Figure 14: Dimensional Data – Double Acting – Sym/Cant – With JL Manual Override.....22

Figure 15: Coupling Details of LPC-05, LPC-10, LPC-12 Symmetric/Canted.....24

Figure 16: LPC-14 Coupling Details – Symmetric/Canted.....25

Figure 17: Details of Namur Vde/Vdi 3845 Adaptor Kit, Available Upon Request.....25

Figure 18: LPC Actuator Spring Return and Double Acting – Exploded Views..... 26–27

LPC Series Compact Actuator Specifications

1. The LPC range of Limitorque Pneumatic Actuators is a robust, lightweight modular Scotch yoke design, available in both spring return and double acting configurations. It is suitable for actuating ball, butterfly and plug valves or any other quarter-turn application.
2. LPC Compact actuators deliver up to 5500 Nm* (4057 ft-lb) of precisely controlled torque. The LPC product range is complementary to the already available range of Limitorque LPS heavy-duty pneumatic Scotch yoke actuators. A similar design philosophy to the one adopted for the large heavy-duty LPS actuators has been applied to the new LPC range, bringing enhanced performance and high reliability.
3. The LPC is available in a selection of standard as well as in different and special material executions, upon request.
 - LPC housing constructed in Nodular Ductile Cast Iron; Carbon Steel or different materials of construction available upon request.
 - Carbon Steel ENP lined Cylinders; Stainless Steel Cylinders, Tie Rods and Spool Pieces available upon request
 - External Tie Rods cylinder construction; protected Tie Rods version available upon request for offshore applications
4. LPC actuators are complemented by a comprehensive range of control systems, including ESD, PST and Quick Closing options. A suite of standard controls systems is available for short delivery, but the Limitorque engineering team can design custom solutions for the largest and most complex customer requirements.
5. To complete the actuation package, LPC actuators are available with accessories such, lockout modules and manual overrides. Limitorque provides engineering design services for mounting hardware, ensuring that your actuation solution is ready to handle the toughest challenges.
6. The LPC actuator is designed to provide a 25-year design life, depending on service conditions, proper installation, operation and maintenance. In order to achieve this industry-leading design life, in-field maintenance is prescribed to be performed every five years of operation. For high-cycle applications, such as control valve operation, more frequent maintenance of replaceable wear surfaces, as outlined in EN 15714, may be required.
7. Suitable for use in on/off, modulating and control valve application in general service, protective service and safety applications such as ESD or HIPPS.
8. The LPC is provided with square output shaft as described in “Mounting Interface Dimensions” paragraph of this Technical Bulletin. It is also available with valve adaptor interface in compliance with ISO 5211 or MSS SP-101, upon request as an option.
9. Manufactured and tested in compliance with **EN 15714-3** and **ISO 12490**.
10. Spring components are designed in compliance with **EN 13906-1**.
11. Surface coating and corrosion protection in compliance with **ISO 12944-2** up to and including **C5-M** if requested.
12. Environmental resistance has been certified to meet or exceed the requirements of **IEC 60529**, including **IP66/66M** and **IP67/67M**.
13. The LPC actuator is suitable for use in Safety Integrated Systems in accordance with **IEC 61508** up to and including **SIL Level 3**.
14. The actuator accessories in the LPC series meet the requirements of **ISO 5599-2**.
15. LPC actuators are available in accordance with **ATEX 94/9/EC Ex II 2GD c IIC T6**, as it relates to mechanical actuators.
16. Actuators are available in compliance with **NACE specification MR0175** for sour gas applications, upon request
17. Shaft-driven accessories/devices are mounted to **VDE VDI 3845 NAMUR** compliant mounting locations, by means of an adaptor available upon request as an option.
18. The actuator is manufactured and tested in compliance with an **ISO 9001** Quality Assurance Program.
19. Integral travel stops provide **90°±5°** of stroke adjustment and are designed for the **MAWP** of the actuator up to **12 barg (174 PSIG)**.
20. The materials of construction and seals of the LPC family of actuators are available for a wide range of service temperatures, including **Tropical, Arid, Temperate, Cold and Polar** regions in accordance with **IEC 60721**.

* Contact factory for larger sizes and higher output torques

21. The pneumatic cylinder design features proven and reliable external tie rods suitable for continuous duty service at the maximum rated pressure. Wear and corrosion protection of all components is ensured with suitable treatments and coatings. **ENP** (electroless nickel plating) is the standard for the internal surface of the pneumatic cylinder to ensure complete sealing and superior corrosion resistance. Other coatings for the internal surface of the cylinder are available upon request. The LPC actuator cylinders are capable of being independently tested prior to assembly.
22. Pressure modules are available upon request in compliance with:
 - a. **Pressure Equipment Directive 97/23/EC**
 - b. **ASME BPVC Sec. VIII Div. 1**
 - c. **EN 13445-3, Part 3 for Unfired Pressure Vessels**
23. All actuators and modules meet acceptance criteria defined by Flowserve test specifications.
24. The LPC is available with either a symmetric or canted Scotch yoke. Scotch yoke cants are available from 1° to 8° upon request, pending on application.
25. All modules align and mate with close-tolerance machined flanges with no exposed threaded connections.
26. The high-strength, heat-treated alloy steel guide bar is hard chrome plated for wear and corrosion protection.
27. The piston rod is detachable from the torque module without special tools and does not require module disassembly.
28. Pressure seals utilize O-rings, quad-rings or V-rings as appropriate to eliminate environmental ingress. No gaskets are used in pressurized regions of the actuator.
29. The push-to-compress springs are safely enclosed by tie rods and positively retained on the torque module under all load conditions. Springs are designed in accordance with **EN 13906-1** and combined and positioned to eliminate potential contact with the container or each other in the case of multiple springs. Springs are shot peened for maximum life and are painted and permanently lubricated and coated prior to assembly to eliminate corrosion.
30. In the LPC single acting execution, the spring is located inside the pneumatic cylinder, like an integral solution.
31. The spring and spring guide are self-centered and bearing guided within the spring module. The spring rod is guided in a self-lubricating bearing and connected to the torque module. Installation and removal of the spring module does not require special tools.
32. Maintenance-free, self-lubricating bearings are used to minimize friction of the yoke, yoke pins and roller bearing in the yoke slots for low friction and to minimize contact stresses in order to provide the longest possible service life.
33. Retention of the yoke pin is by a retaining washer to permit easy removal of the yoke pin while the actuator is mounted on the valve. No special tools are required.

Actuator Selection Table

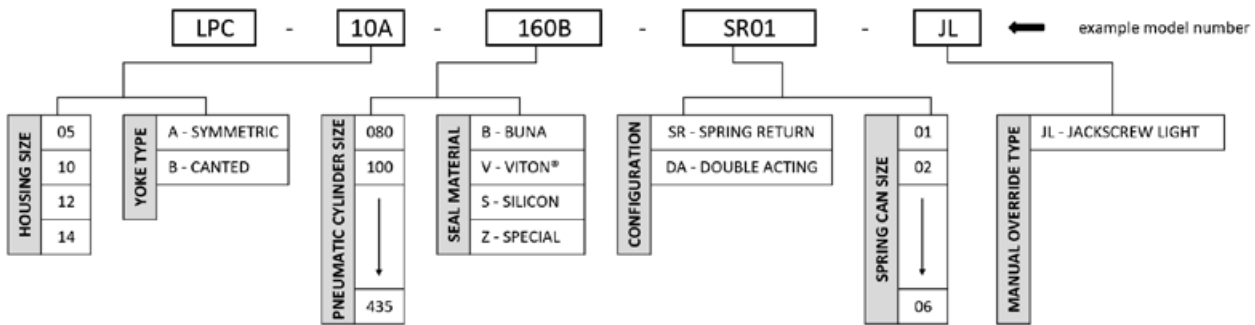

Seals Material

Code	Material	Temperature Range	Climate Classification according to IEC60721
B	Buna	Std Temp: -29°C to +100°C (-20°F to 212°F)	Tropical & Arid
V	Viton®	Hi Temp: up to +160°C (320°F)	
S	Silicon	Low Temp: down to -40°C (-40°F)	Temperate
Z	Other	Special Applications: Consult Factory	Cold & Polar

LPC Torque and Pressure Table

Model	MOT Maximum Operating Torque Nm (ft-lb)	MOP Maximum Operating Pressure barg (PSIG)	MAWP Maximum Allowable Working Pressure barg (PSIG)
LPC-05	500 (369)	Variable for every model	12 (174)
LPC-10	1600 (1180)		
LPC-12	3500 (2582)		
LPC-14	5500 (4057)		

Actuator Selection Guidance

1. Scope

This section provides guidance for the selection of the proper LPC actuator to suit specific operational requirements. A basic understanding of Scotch yoke actuators and the typical applications in which they are used is provided in order to assist in selection of the most suitable actuator. While the selection procedures and product data contained herein cover many applications, due to the

wide range of applications in which the LPC actuators can be used, this information will not cover every set of operational requirements. The Limitorque applications team is always available to assess specific applications and help with selection of the appropriate LPC actuators. Please contact your local office for assistance.

2. General Definitions/Terms Used

Quarter-turn	A device that rotates by a nominal 90°. LPC series actuators rotate ± 5° more than the nominal 90°.
Position	The degree of rotation describing an actuator's current location, the zero being referred from complete counterclockwise position of the yoke. The mid-position of the actuator is at 45° and 90° being the end of clockwise stroke.
CW	Clockwise rotation.
CCW	Counterclockwise rotation.
Stroke	A continuous, 90° rotation of a quarter-turn actuator.
Cycle	Two strokes, one clockwise (CW) rotation and other counterclockwise (CCW) rotation, constitute one cycle of operation of the actuator.

*Viton is a registered trademark of E. I. du Pont de Nemours.

Safety Factor	A factor multiplied by the valve's basic required torque value to increase the amount of torque required to meet safety requirements in a given application. When the valve's torque requirements are not known with certainty, or due to other application demands, use of a safety factor is required in the selection process in order to meet the worst-case torque requirements.
Pneumatic Break Torque	Output torque when the actuator is in the position to start the pressure stroke. [The torque required to initiate the pressure stroke.]
Pneumatic End Torque	Output torque at the end limit of the pressure stroke. [The torque required to seat the valve at the end of the pressure stroke.]
Run Torque	The output torque recorded while the actuator is in the mid-position of the pressure stroke (45°). For symmetrical yoke double-acting actuators, this is the minimum torque output obtained during the complete stroke.
Spring Break Torque	The output torque when the actuator is in the position to start the spring stroke. [The torque required to initiate the spring stroke.] The spring is fully compressed at this position and generates the maximum spring force.
Spring End Torque	The output torque when the actuator has reached the end limit of spring stroke. [The torque required to seat the valve at the end of the spring stroke.] The spring is fully extended at this position and generates the minimum spring force.
Minimum Torque	The output torque at an intermediate position of the spring stroke, where the output torque of the actuator is at its lowest value.
MOP	Maximum operating pressure of an actuator.

3. Inputs for Sizing Pneumatic Scotch Yoke Actuators

Due to the Scotch yoke mechanism, LPC actuators have a particular U-shaped output torque curve, whether powered by a fixed supply pressure or the spring.

For a proper actuator model selection, the safety factors between actuator output torque and valve torque requirement shall be calculated at least in six points along the valve stroke. In addition, a final check is necessary to guarantee that actuator Maximum Output Torque does not exceed valve Maximum Allowable Stem Torque (MAST).

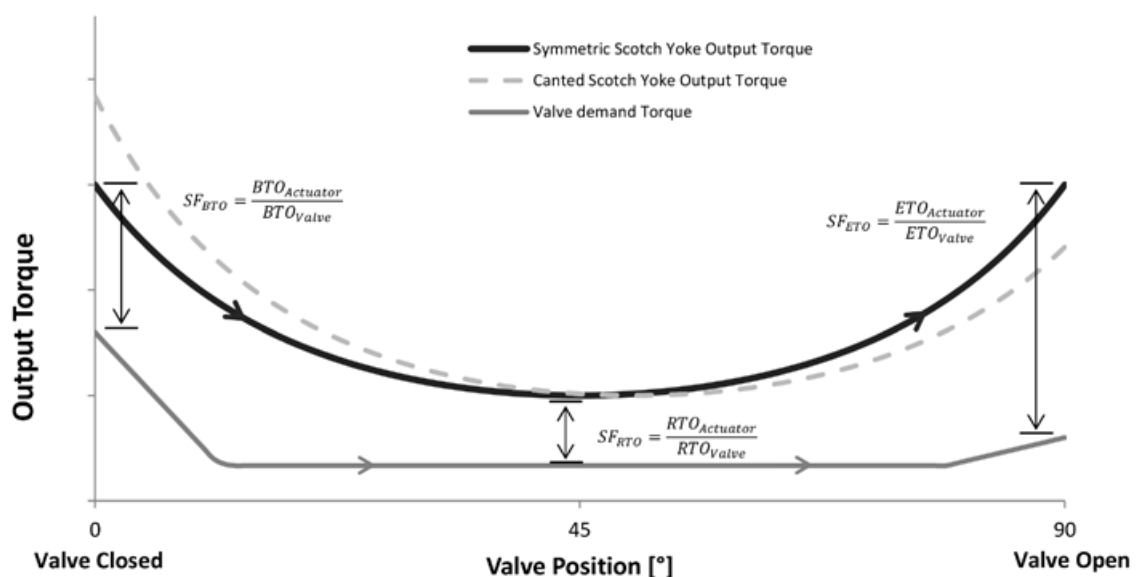

Figure 1: Actuator OPEN (by instr. air) Torque Curve: Single Acting Spring Return – Fail Close (CW)

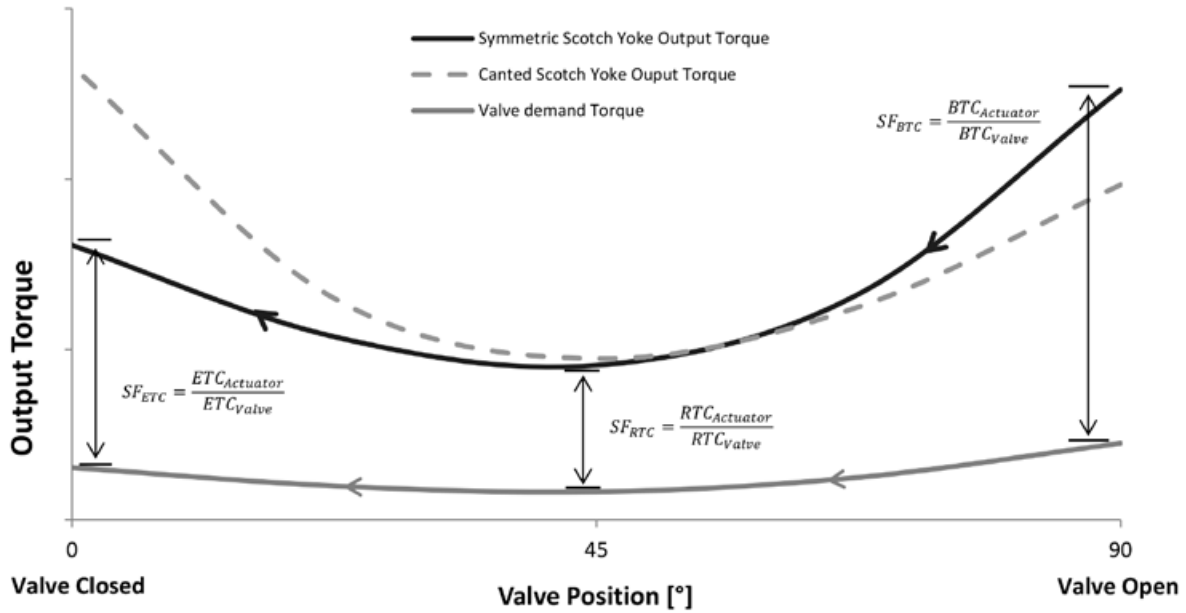

Figure 2: Actuator CLOSE (by spring) Torque Curve: Single Acting Spring Return – Fail Close (CW)

Note: Detailed Output Torque graphs covering the full valve stroke for both Single Acting Fail Open (CCW) and Double Acting actuators are available upon request.

The minimum set of parameters and features necessary for an optimized actuator selection:

- Valve torques, or at least the unseating torque (BTO), and valve MAST
- Type of actuator:
 - Single Acting/Spring Return: Fail Safe Close (CW) or Fail Safe Open (CCW)
 - Double Acting configuration for Fail Last or Fail As Is
- Minimum, Normal and Maximum Pneumatic Supply Pressure to the actuator
- Safety Factors requested by the project or by a specific application
- Working Temperature range
- Open/Close stroking times
- Additional options (manual override, control panel, limit switch box, positioner, ...)

Definitions:

- BTO = Break to Open torque
- BTC = Break to Close torque
- RTO = Running to Open torque
- RTC = Running to Close torque
- ETO = End to Open torque
- ETC = End to Close torque
- MAST = Maximum Allowable Stem Torque
- SF = Safety Factor

4. LPC Manual Overrides

A range of Mechanical Manual Override options are available for LPC Compact pneumatic actuators for both single acting (spring-return) and double acting actuator models. Manual overrides are necessary to allow operating valve actuator whenever the motive pressure (e.g. instrument air) and/or the electrical power are not available. LFPS manual overrides are designed in accordance with EN 12570. Special external thread coating and protection is also available for offshore applications, upon request. Hydraulic Hand Pump is available upon request, not as a standard feature for LPC actuators.

Suffix	Description	LPC Actuator Model			
		LPC-05	LPC-10	LPC-12	LPC-14
-JL	Jackscrew Light Handwheel	✓	✓	✓	✓
-JS	Enclosed Jackscrew Handwheel	-	-	-	-
-BG	Bevel Gear Handwheel	-	-	-	-
-HP	Hydraulic Manual Hand Pump	-	-	-	-

JL Jackscrew Light

- Simple and economical manual override option
- Direct operating handwheel screwed on the cylinder/housing side
- Rotating and sliding threaded external screw
- Integral and adjustable not-enclosed travel stop
- Handwheel may be optionally replaced by portable wrench
- Special exposed threads coating and special protection suitable for offshore/marine applications, available upon request



Figure 3: LPC Double Acting Actuator With JL Jackscrew Manual Override



Figure 4: LPC Single Acting Actuator With JL Jackscrew Manual Override

5. Fail Open/Fail Close and Double Acting Configurations

The LPC actuator is designed for work in both single acting (fail open and fail close) and double acting configurations:

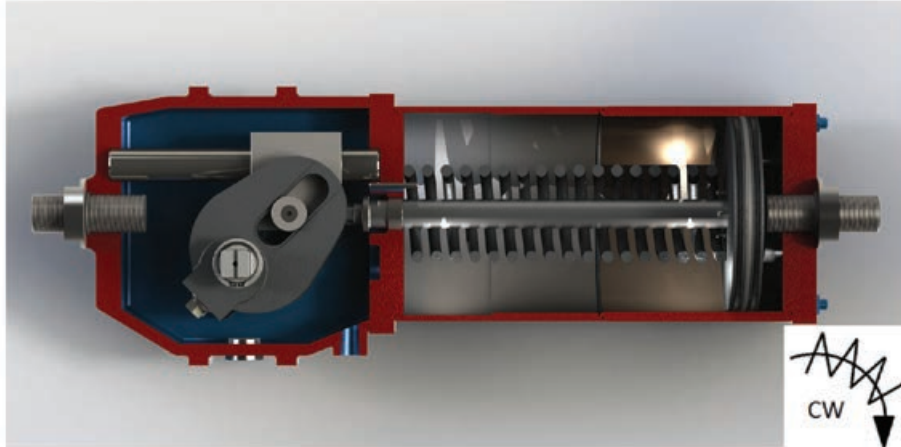

Figure 5: Single Acting Actuator Configuration: Fail Close – Fail Clockwise

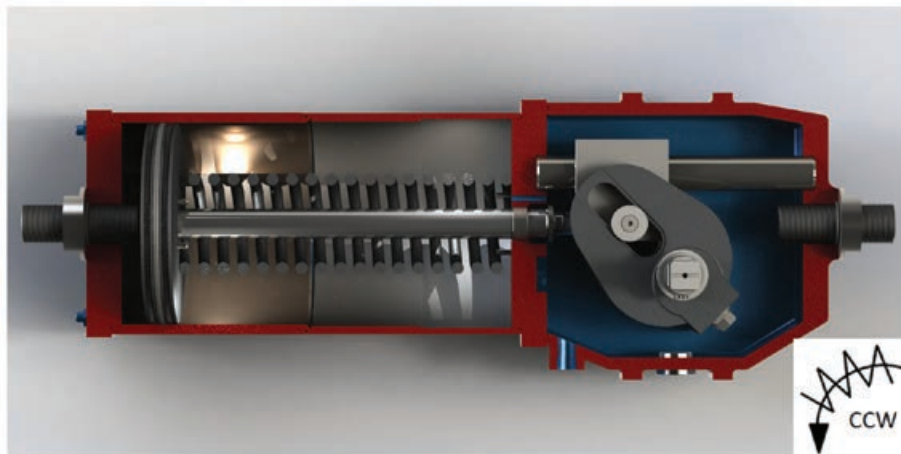

Figure 6: Single Acting Actuator Configuration: Fail Open – Fail Counterclockwise

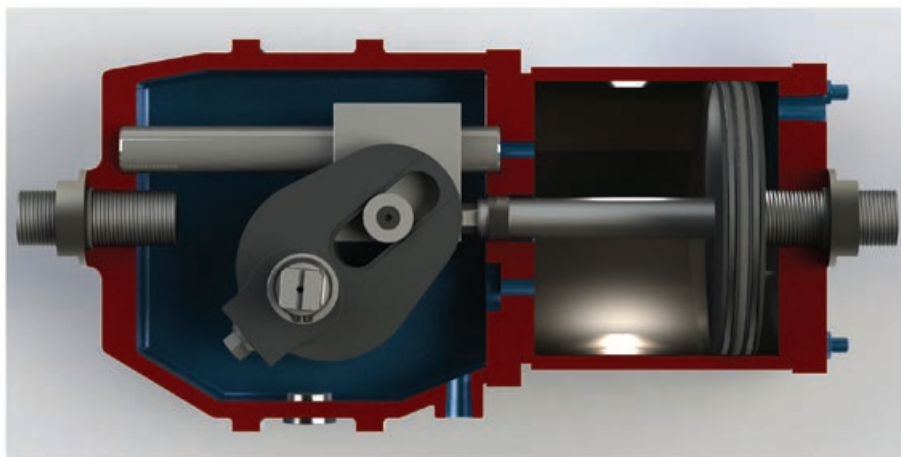

Figure 7: Double Acting Actuator Configuration – Close Position

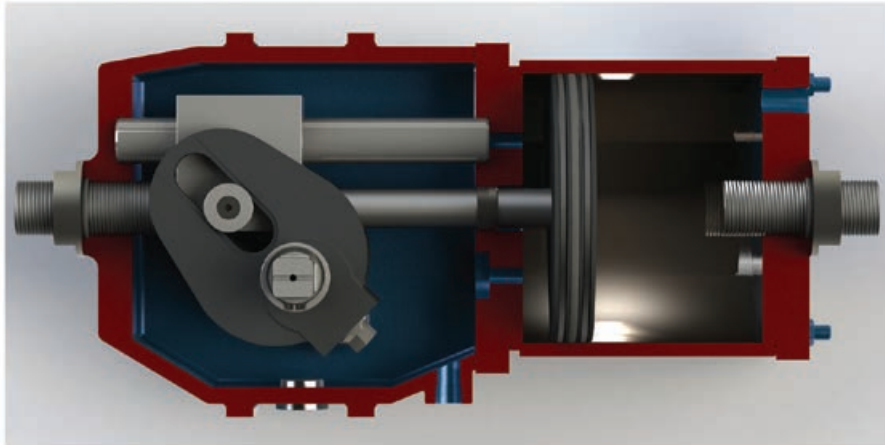

Figure 8: Double Acting Actuator Configuration – Open Position

6. Performance Data

Performance data for LPC actuators is available upon request. For correct selection of LPC actuators, consult Limatorque Flowserve Application Engineers or local Sales Support.

Note: Provided performance data may be subject to variations due to continuous improvement of LPC products. For latest data, please contact Flowserve and/or refer to technical documentation transmitted along with the quotes or job documentation.

7. Dimensions

The following Dimensions & Weight tables include main external dimensions referred to the relevant pictures included in each section. The overall lengths, the weights, the mounting dimension details, the interface dimensions and the tolerances are included as a guide for actuator selection.

The stated dimensions and weights include the actuators, dimensions only, without any optional features, like the spool pieces, manual overrides, control panels, etc.

Note: Provided dimensional data and weights may be subject to variations due to continuous improvement of LPC products. For latest data, please contact Flowserve and/or refer to technical documentation transmitted along with the quotes or job documentation.

8. Disclaimer

This publication is presented for information purposes only, with an effort to ensure the accuracy, the contents are not to be construed as warranties or guarantees, expressed or implied, regarding the products or services described herein or their use or applicability. The right to modify or improve the designs or specifications of our products at any time without notice is reserved.

Dimensional Data and Weights – LPC Single Acting

Figure 9: Dimensional Data – Single Acting – Sym/Cant – Fail Close

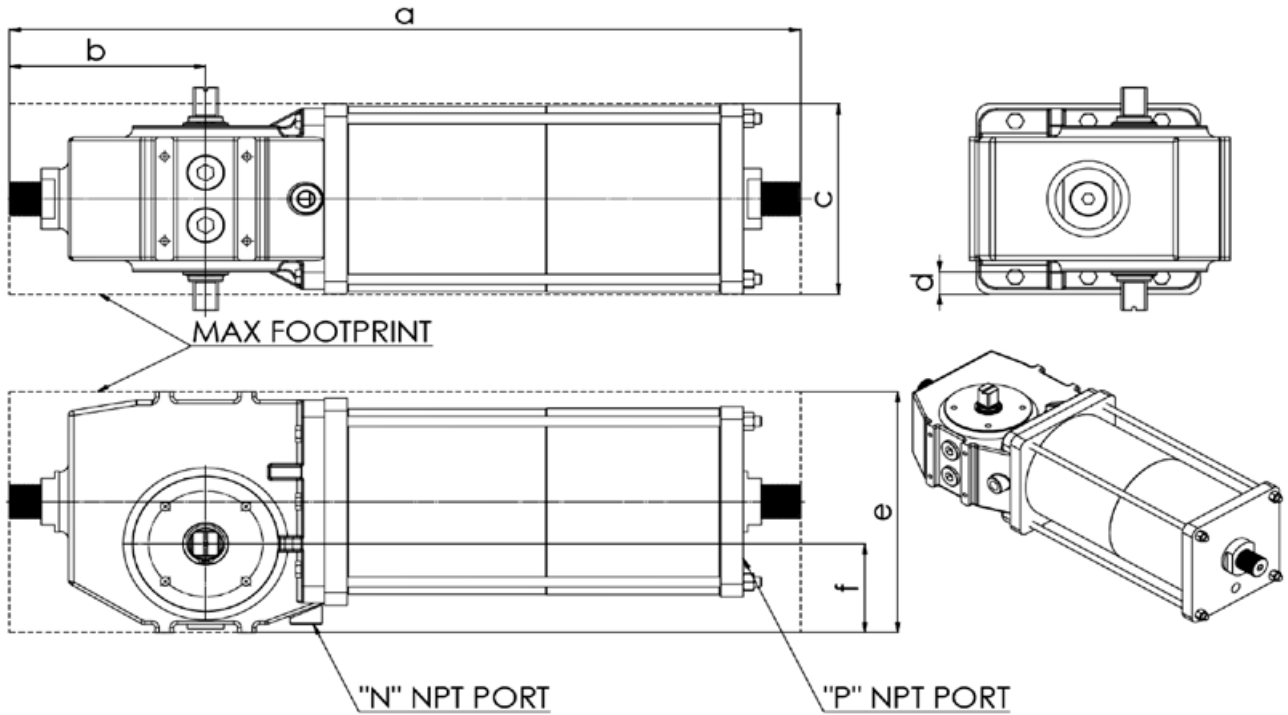

Figure 10: Dimensional Data – Single Acting – Sym/Cant – Fail Open

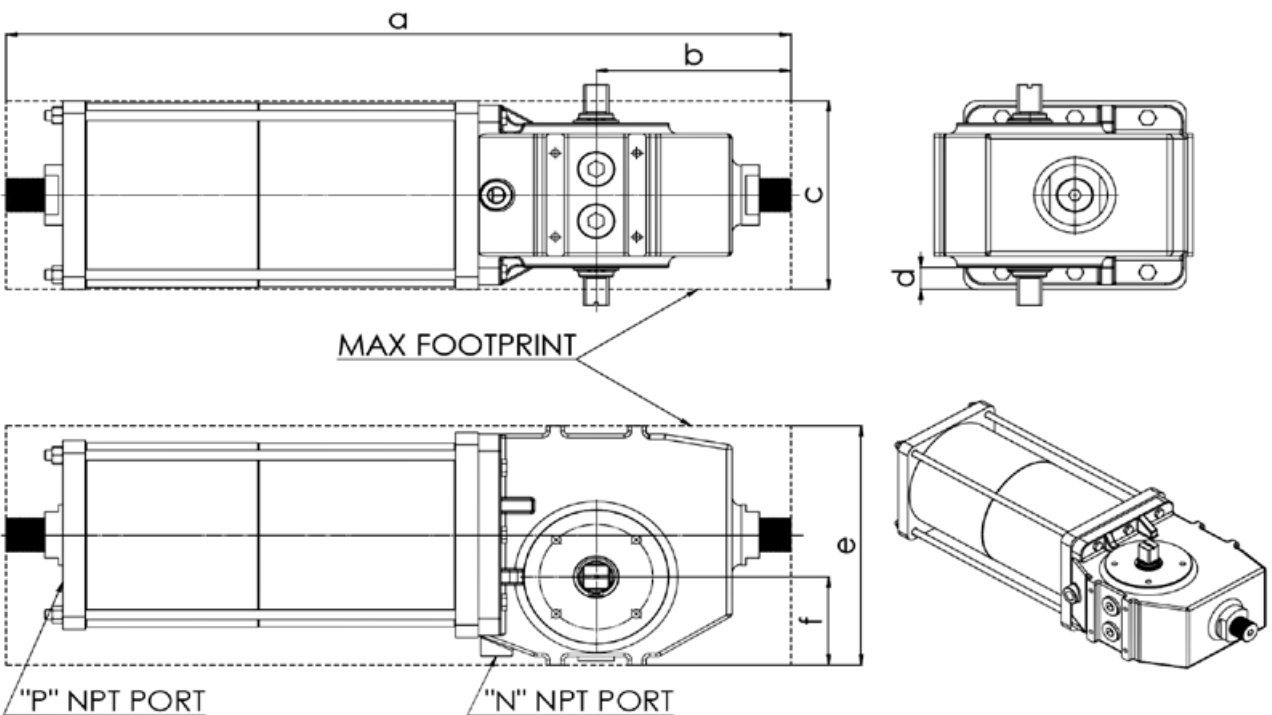

Table 1: LPC Single Acting – Dimensional, Weight and Volume Tables

LPC - Single Acting - Dimensions: mm (in) - Weights: Kg (lbs) - Swept Volumes: l (cu in) - MOT Nm (ft-lb)											
Model	a*	b*	c	d	e	f	"P" NPT PORT	"N" NPT PORT	Weight	Swept volume*	MOT
LPC-05X-080Y-SR01	688	173	175	18	197	69	1/4"	1/4"	37	0,5	550
	27,1	6,8	6,9	0,7	7,8	2,7			82	31	369
LPC-05X-080Y-SR02	688	173	175	18	197	69	1/4"	1/4"	38	0,5	550
	27,1	6,8	6,9	0,7	7,8	2,7			83	31	369
LPC-05X-100Y-SR01	688	173	175	18	197	69	1/4"	1/4"	43	0,8	550
	27,1	6,8	6,9	0,7	7,8	2,7			94	49	369
LPC-05X-100Y-SR02	688	173	175	18	197	69	1/4"	1/4"	43	0,8	550
	27,1	6,8	6,9	0,7	7,8	2,7			95	49	369
LPC-05X-100Y-SR03	688	173	175	18	197	69	1/4"	1/4"	44	0,8	550
	27,1	6,8	6,9	0,7	7,8	2,7			96	49	369
LPC-05X-120Y-SR01	688	173	175	18	197	69	1/4"	1/4"	44	1,2	550
	27,1	6,8	6,9	0,7	7,8	2,7			97	73	369
LPC-05X-120Y-SR02	688	173	175	18	197	69	1/4"	1/4"	44	1,2	550
	27,1	6,8	6,9	0,7	7,8	2,7			98	73	369
LPC-05X-120Y-SR03	688	173	175	18	197	69	1/4"	1/4"	45	1,2	550
	27,1	6,8	6,9	0,7	7,8	2,7			99	73	369
LPC-05X-120Y-SR04	688	173	175	18	197	69	1/4"	1/4"	45	1,2	550
	27,1	6,8	6,9	0,7	7,8	2,7			100	73	369
LPC-05X-120Y-SR05	688	173	175	18	197	69	1/4"	1/4"	46	1,2	550
	27,1	6,8	6,9	0,7	7,8	2,7			102	73	369
LPC-05X-140Y-SR01	688	173	175	18	197	69	1/4"	1/4"	47	1,6	550
	27,1	6,8	6,9	0,7	7,8	2,7			104	98	369
LPC-05X-140Y-SR02	688	173	175	18	197	69	1/4"	1/4"	48	1,6	550
	27,1	6,8	6,9	0,7	7,8	2,7			106	98	369
LPC-05X-140Y-SR03	688	173	175	18	197	69	1/4"	1/4"	48	1,6	550
	27,1	6,8	6,9	0,7	7,8	2,7			107	98	369
LPC-05X-140Y-SR04	688	173	175	18	197	69	1/4"	1/4"	49	1,6	550
	27,1	6,8	6,9	0,7	7,8	2,7			108	98	369
LPC-05X-140Y-SR05	688	173	175	18	197	69	1/4"	1/4"	50	1,6	550
	27,1	6,8	6,9	0,7	7,8	2,7			110	98	369
LPC-05X-140Y-SR06	688	173	175	18	197	69	1/4"	1/4"	54	1,6	550
	27,1	6,8	6,9	0,7	7,8	2,7			119	98	369
LPC-05X-160Y-SR01	688	173	185	23	200	69	1/2"	1/4"	53	2,1	550
	27,1	6,8	7,3	0,9	7,9	2,7			117	128	369
LPC-05X-160Y-SR02	688	173	185	23	200	69	1/2"	1/4"	54	2,1	550
	27,1	6,8	7,3	0,9	7,9	2,7			118	128	369
LPC-05X-160Y-SR03	688	173	185	23	200	69	1/2"	1/4"	54	2,1	550
	27,1	6,8	7,3	0,9	7,9	2,7			119	128	369
LPC-05X-160Y-SR04	688	173	185	23	200	69	1/2"	1/4"	55	2,1	550
	27,1	6,8	7,3	0,9	7,9	2,7			120	128	369
LPC-05X-160Y-SR05	688	173	185	23	200	69	1/2"	1/4"	56	2,1	550
	27,1	6,8	7,3	0,9	7,9	2,7			122	128	369
LPC-05X-160Y-SR06	688	173	185	23	200	69	1/2"	1/4"	57	2,1	550
	27,1	6,8	7,3	0,9	7,9	2,7			126	128	369
LPC-10X-100Y-SR01	846	205	245	37	285	105	1/4"	1/2"	68	1,1	1600
	33,3	8,1	9,6	1,4	11,2	4,1			150	67	1180
LPC-10X-120Y-SR01	846	205	245	37	285	105	1/4"	1/2"	72	1,5	1600
	33,3	8,1	9,6	1,4	11,2	4,1			159	92	1180
LPC-10X-120Y-SR02	846	205	245	37	285	105	1/4"	1/2"	74	1,5	1600
	33,3	8,1	9,6	1,4	11,2	4,1			163	92	1180
LPC-10X-140Y-SR01	846	205	245	37	285	105	1/4"	1/2"	77	2,1	1600
	33,3	8,1	9,6	1,4	11,2	4,1			169	128	1180
LPC-10X-140Y-SR02	846	205	245	37	285	105	1/4"	1/2"	79	2,1	1600
	33,3	8,1	9,6	1,4	11,2	4,1			174	128	1180
LPC-10X-140Y-SR03	889	205	245	37	285	105	1/4"	1/2"	81	2,1	1600
	35,0	8,1	9,6	1,4	11,2	4,1			179	128	1180
LPC-10X-160Y-SR01	846	205	245	37	285	105	1/2"	1/2"	79	2,7	1600
	33,3	8,1	9,6	1,4	11,2	4,1			175	165	1180
LPC-10X-160Y-SR02	846	205	245	37	285	105	1/2"	1/2"	81	2,7	1600
	33,3	8,1	9,6	1,4	11,2	4,1			178	165	1180
LPC-10X-160Y-SR03	889	205	245	37	285	105	1/2"	1/2"	83	2,7	1600
	35,0	8,1	9,6	1,4	11,2	4,1			183	165	1180
LPC-10X-160Y-SR04	889	205	245	37	285	105	1/2"	1/2"	85	2,7	1600
	35,0	8,1	9,6	1,4	11,2	4,1			188	165	1180
LPC-10X-160Y-SR05	932	205	245	37	285	105	1/2"	1/2"	87	2,7	1600
	36,7	8,1	9,6	1,4	11,2	4,1			192	165	1180
LPC-10X-180Y-SR01	846	205	245	37	285	105	1/2"	1/2"	90	3,4	1600
	33,3	8,1	9,6	1,4	11,2	4,1			199	207	1180
LPC-10X-180Y-SR02	846	205	245	37	285	105	1/2"	1/2"	92	3,4	1600
	33,3	8,1	9,6	1,4	11,2	4,1			202	207	1180
LPC-10X-180Y-SR03	889	205	245	37	285	105	1/2"	1/2"	93	3,4	1600
	35,0	8,1	9,6	1,4	11,2	4,1			206	207	1180
LPC-10X-180Y-SR04	889	205	245	37	285	105	1/2"	1/2"	96	3,4	1600
	35,0	8,1	9,6	1,4	11,2	4,1			211	207	1180
LPC-10X-180Y-SR05	932	205	245	37	285	105	1/2"	1/2"	97	3,4	1600
	36,7	8,1	9,6	1,4	11,2	4,1			215	207	1180

(*) Note: Swept Volume and overall dimensions data are referred to actuators with end stops adjusted for 90° of stroke. Refer to Figure for details of Ports "N" and "P".

LPC - Single Acting - Dimensions: mm (in) - Weights: Kg (lbs) - Swept Volumes: l (cu in) - MOT Nm (ft-lb)											
Model	a*	b*	c	d	e	f	"P" NPT PORT	"N" NPT PORT	Weight	Swept volume*	MOT
LPC-10X-180Y-SR06	932	205	245	37	285	105	1/2"	1/2"	99	3,4	1600
	36,7	8,1	9,6	1,4	11,2	4,1			219	207	1180
LPC-10X-200Y-SR01	846	205	245	37	285	105	1/2"	1/2"	99	4,2	1600
	33,3	8,1	9,6	1,4	11,2	4,1			218	256	1180
LPC-10X-200Y-SR02	846	205	245	37	285	105	1/2"	1/2"	100	4,2	1600
	33,3	8,1	9,6	1,4	11,2	4,1			221	256	1180
LPC-10X-200Y-SR03	889	205	245	37	285	105	1/2"	1/2"	102	4,2	1600
	35,0	8,1	9,6	1,4	11,2	4,1			226	256	1180
LPC-10X-200Y-SR04	889	205	245	37	285	105	1/2"	1/2"	105	4,2	1600
	35,0	8,1	9,6	1,4	11,2	4,1			231	256	1180
LPC-10X-200Y-SR05	932	205	245	37	285	105	1/2"	1/2"	106	4,2	1600
	36,7	8,1	9,6	1,4	11,2	4,1			234	256	1180
LPC-10X-200Y-SR06	932	205	245	37	285	105	1/2"	1/2"	109	4,2	1600
	36,7	8,1	9,6	1,4	11,2	4,1			241	256	1180
LPC-10X-220Y-SR01	846	205	245	37	285	105	1/2"	1/2"	115	5,1	1600
	33,3	8,1	9,6	1,4	11,2	4,1			254	311	1180
LPC-10X-220Y-SR02	846	205	245	37	285	105	1/2"	1/2"	117	5,1	1600
	33,3	8,1	9,6	1,4	11,2	4,1			257	311	1180
LPC-10X-220Y-SR03	889	205	245	37	285	105	1/2"	1/2"	119	5,1	1600
	35,0	8,1	9,6	1,4	11,2	4,1			261	311	1180
LPC-10X-220Y-SR04	889	205	245	37	285	105	1/2"	1/2"	121	5,1	1600
	35,0	8,1	9,6	1,4	11,2	4,1			266	311	1180
LPC-10X-220Y-SR05	932	205	245	37	285	105	1/2"	1/2"	122	5,1	1600
	36,7	8,1	9,6	1,4	11,2	4,1			269	311	1180
LPC-10X-220Y-SR06	932	205	245	37	285	105	1/2"	1/2"	124	5,1	1600
	36,7	8,1	9,6	1,4	11,2	4,1			273	311	1180
LPC-12X-140Y-SR01	927	214	243	28	285	101	1/4"	3/4"	100	2,2	3500
	36,5	8,4	9,6	1,1	11,2	4,0			221	136	2581
LPC-12X-160Y-SR01	927	214	243	28	285	101	1/2"	3/4"	105	2,8	3500
	36,5	8,4	9,6	1,1	11,2	4,0			230	174	2581
LPC-12X-160Y-SR02	927	214	243	28	285	101	1/2"	3/4"	107	2,8	3500
	36,5	8,4	9,6	1,1	11,2	4,0			235	174	2581
LPC-12X-160Y-SR03	1038	214	243	28	285	101	1/2"	3/4"	115	2,8	3500
	40,9	8,4	9,6	1,1	11,2	4,0			254	174	2581
LPC-12X-180Y-SR01	927	214	243	28	285	101	1/2"	3/4"	109	3,5	3500
	36,5	8,4	9,6	1,1	11,2	4,0			240	217	2581
LPC-12X-180Y-SR02	927	214	243	28	285	101	1/2"	3/4"	111	3,5	3500
	36,5	8,4	9,6	1,1	11,2	4,0			244	217	2581
LPC-12X-180Y-SR03	1038	214	243	28	285	101	1/2"	3/4"	120	3,5	3500
	40,9	8,4	9,6	1,1	11,2	4,0			264	217	2581
LPC-12X-180Y-SR04	1038	214	243	28	285	101	1/2"	3/4"	124	3,5	3500
	40,9	8,4	9,6	1,1	11,2	4,0			273	217	2581
LPC-12X-200Y-SR01	927	214	243	28	285	101	1/2"	3/4"	113	4,4	3500
	36,5	8,4	9,6	1,1	11,2	4,0			250	273	2581
LPC-12X-200Y-SR02	927	214	243	28	285	101	1/2"	3/4"	115	4,4	3500
	36,5	8,4	9,6	1,1	11,2	4,0			254	273	2581
LPC-12X-200Y-SR03	1038	214	243	28	285	101	1/2"	3/4"	125	4,4	3500
	40,9	8,4	9,6	1,1	11,2	4,0			276	273	2581
LPC-12X-200Y-SR04	1038	214	243	28	285	101	1/2"	3/4"	129	4,4	3500
	40,9	8,4	9,6	1,1	11,2	4,0			284	273	2581
LPC-12X-200Y-SR05	1038	214	243	28	285	101	1/2"	3/4"	130	4,4	3500
	40,9	8,4	9,6	1,1	11,2	4,0			287	273	2581
LPC-12X-235Y-SR01	927	214	260	36	289	101	1/2"	3/4"	125	6,1	3500
	36,5	8,4	10,2	1,4	11,4	4,0			275	378	2581
LPC-12X-235Y-SR02	927	214	260	36	289	101	1/2"	3/4"	127	6,1	3500
	36,5	8,4	10,2	1,4	11,4	4,0			280	378	2581
LPC-12X-235Y-SR03	1038	214	260	36	289	101	1/2"	3/4"	137	6,1	3500
	40,9	8,4	10,2	1,4	11,4	4,0			303	378	2581
LPC-12X-235Y-SR04	1038	214	260	36	289	101	1/2"	3/4"	141	6,1	3500
	40,9	8,4	10,2	1,4	11,4	4,0			311	378	2581
LPC-12X-235Y-SR05	1038	214	260	36	289	101	1/2"	3/4"	142	6,1	3500
	40,9	8,4	10,2	1,4	11,4	4,0			313	378	2581
LPC-12X-235Y-SR06	1038	214	260	36	289	101	1/2"	3/4"	152	6,1	3500
	40,9	8,4	10,2	1,4	11,4	4,0			334	378	2581
LPC-12X-285Y-SR01	922	214	363	88	363	124	1"	3/4"	152	9	3500
	36,3	8,4	14,3	3,4	14,3	4,9			335	558	2581
LPC-12X-285Y-SR02	922	214	363	88	363	124	1"	3/4"	156	9	3500
	36,3	8,4	14,3	3,4	14,3	4,9			343	558	2581
LPC-12X-285Y-SR03	1033	214	363	88	363	124	1"	3/4"	165	9	3500
	40,7	8,4	14,3	3,4	14,3	4,9			363	558	2581
LPC-12X-285Y-SR04	1033	214	363	88	363	124	1"	3/4"	172	9	3500
	40,7	8,4	14,3	3,4	14,3	4,9			378	558	2581
LPC-12X-285Y-SR05	1033	214	363	88	363	124	1"	3/4"	173	9	3500
	40,7	8,4	14,3	3,4	14,3	4,9			380	558	2581
LPC-12X-285Y-SR06	1033	214	363	88	363	124	1"	3/4"	182	9	3500
	40,7	8,4	14,3	3,4	14,3	4,9			401	558	2581

(*) Note: Swept Volume and overall dimensions data are referred to actuators with end stops adjusted for 90° of stroke. Refer to Figure for details of Ports "N" and "P".



LPC - Single Acting - Dimensions: mm (in) - Weights: Kg (lbs) - Swept Volumes: l (cu in) - MOT Nm (ft-lb)											
Model	a*	b*	c	d	e	f	"P" NPT PORT	"N" NPT PORT	Weight	Swept volume*	MOT
LPC-12X-335Y-SR01	927	214	413	113	413	149	1"	3/4"	179	12,3	3500
	36,5	8,4	16,3	4,4	16,3	5,8			395	763	2581
LPC-12X-335Y-SR02	927	214	413	113	413	149	1"	3/4"	182	12,3	3500
	36,5	8,4	16,3	4,4	16,3	5,8			402	763	2581
LPC-12X-335Y-SR03	1038	214	413	113	413	149	1"	3/4"	193	12,3	3500
	40,9	8,4	16,3	4,4	16,3	5,8			426	763	2581
LPC-12X-335Y-SR04	1038	214	413	113	413	149	1"	3/4"	200	12,3	3500
	40,9	8,4	16,3	4,4	16,3	5,8			441	763	2581
LPC-12X-335Y-SR05	1038	214	413	113	413	149	1"	3/4"	201	12,3	3500
	40,9	8,4	16,3	4,4	16,3	5,8			444	763	2581
LPC-12X-335Y-SR06	1038	214	413	113	413	149	1"	3/4"	211	12,3	3500
	40,9	8,4	16,3	4,4	16,3	5,8			465	763	2581
LPC-14X-180Y-SR01	1140	263	284	31	316	116	1/2"	3/4"	152	4,1	5500
	44,9	10,4	11,2	1,2	12,4	4,6			334	254	4057
LPC-14X-235Y-SR01	1140	263	284	31	316	116	1/2"	3/4"	168	7	5500
	44,9	10,4	11,2	1,2	12,4	4,6			370	434	4057
LPC-14X-235Y-SR02	1140	263	284	31	316	116	1/2"	3/4"	172	7	5500
	44,9	10,4	11,2	1,2	12,4	4,6			379	434	4057
LPC-14X-235Y-SR03	1140	263	284	31	316	116	1/2"	3/4"	182	7	5500
	44,9	10,4	11,2	1,2	12,4	4,6			402	434	4057
LPC-14X-285Y-SR01	1135	263	371	75	371	121	1"	3/4"	194	10,2	5500
	44,7	10,4	14,6	2,9	14,6	4,7			429	632	4057
LPC-14X-285Y-SR02	1135	263	371	75	371	121	1"	3/4"	198	10,2	5500
	44,7	10,4	14,6	2,9	14,6	4,7			437	632	4057
LPC-14X-285Y-SR03	1135	263	371	75	371	121	1"	3/4"	209	10,2	5500
	44,7	10,4	14,6	2,9	14,6	4,7			460	632	4057
LPC-14X-285Y-SR04	1110	263	371	75	371	121	1"	3/4"	184	10,2	5500
	43,7	10,4	14,6	2,9	14,6	4,7			405	632	4057
LPC-14X-335Y-SR01	1140	263	413	96	413	142	1"	3/4"	227	14,1	5500
	44,9	10,4	16,3	3,8	16,3	5,6			500	874	4057
LPC-14X-335Y-SR02	1140	263	413	96	413	142	1"	3/4"	231	14,1	5500
	44,9	10,4	16,3	3,8	16,3	5,6			508	874	4057
LPC-14X-335Y-SR03	1140	263	413	96	413	142	1"	3/4"	241	14,1	5500
	44,9	10,4	16,3	3,8	16,3	5,6			532	874	4057
LPC-14X-335Y-SR04	1115	263	413	96	413	142	1"	3/4"	216	14,1	5500
	43,9	10,4	16,3	3,8	16,3	5,6			476	874	4057
LPC-14X-335Y-SR05	1115	263	413	96	413	142	1"	3/4"	247	14,1	5500
	43,9	10,4	16,3	3,8	16,3	5,6			545	874	4057
LPC-14X-335Y-SR06	1115	263	413	96	413	142	1"	3/4"	268	14,1	5500
	43,9	10,4	16,3	3,8	16,3	5,6			590	874	4057
LPC-14X-360Y-SR01	1140	263	439	109	439	155	1"	3/4"	246	16,3	5500
	44,9	10,4	17,3	4,3	17,3	6,1			543	1011	4057
LPC-14X-360Y-SR02	1140	263	439	109	439	155	1"	3/4"	250	16,3	5500
	44,9	10,4	17,3	4,3	17,3	6,1			551	1011	4057
LPC-14X-360Y-SR03	1140	263	439	109	439	155	1"	3/4"	261	16,3	5500
	44,9	10,4	17,3	4,3	17,3	6,1			574	1011	4057
LPC-14X-360Y-SR04	1115	263	439	109	439	155	1"	3/4"	235	16,3	5500
	43,9	10,4	17,3	4,3	17,3	6,1			518	1011	4057
LPC-14X-360Y-SR05	1115	263	439	109	439	155	1"	3/4"	264	16,3	5500
	43,9	10,4	17,3	4,3	17,3	6,1			582	1011	4057
LPC-14X-360Y-SR06	1115	263	439	109	439	155	1"	3/4"	283	16,3	5500
	43,9	10,4	17,3	4,3	17,3	6,1			624	1011	4057
LPC-14X-385Y-SR01	1140	263	465	122	465	168	1"	3/4"	265	18,7	5500
	44,9	10,4	18,3	4,8	18,3	6,6			584	1159	4057
LPC-14X-385Y-SR02	1140	263	465	122	465	168	1"	3/4"	269	18,7	5500
	44,9	10,4	18,3	4,8	18,3	6,6			592	1159	4057
LPC-14X-385Y-SR03	1140	263	465	122	465	168	1"	3/4"	269	18,7	5500
	44,9	10,4	18,3	4,8	18,3	6,6			592	1159	4057
LPC-14X-385Y-SR04	1115	263	465	122	465	168	1"	3/4"	279	18,7	5500
	43,9	10,4	18,3	4,8	18,3	6,6			616	1159	4057
LPC-14X-385Y-SR05	1115	263	465	122	465	168	1"	3/4"	253	18,7	5500
	43,9	10,4	18,3	4,8	18,3	6,6			559	1159	4057
LPC-14X-385Y-SR06	1110	263	465	122	465	168	1"	3/4"	285	18,7	5500
	43,7	10,4	18,3	4,8	18,3	6,6			627	1159	4057
LPC-14X-435Y-SR01	1140	263	526	152	526	198	1"	3/4"	316	23,8	5500
	44,9	10,4	20,7	6,0	20,7	7,8			696	1476	4057
LPC-14X-435Y-SR02	1140	263	526	152	526	198	1"	3/4"	320	23,8	5500
	44,9	10,4	20,7	6,0	20,7	7,8			705	1476	4057
LPC-14X-435Y-SR03	1140	263	526	152	526	198	1"	3/4"	330	23,8	5500
	44,9	10,4	20,7	6,0	20,7	7,8			728	1476	4057
LPC-14X-435Y-SR04	1115	263	526	152	526	198	1"	3/4"	304	23,8	5500
	43,9	10,4	20,7	6,0	20,7	7,8			670	1476	4057
LPC-14X-435Y-SR05	1115	263	526	152	526	198	1"	3/4"	335	23,8	5500
	43,9	10,4	20,7	6,0	20,7	7,8			739	1476	4057
LPC-14X-435Y-SR06	1115	263	526	152	526	198	1"	3/4"	352	23,8	5500
	43,9	10,4	20,7	6,0	20,7	7,8			776	1476	4057

(*) Note: Swept Volume and overall dimensions data are referred to actuators with end stops adjusted for 90° of stroke. Refer to Figure for details of Ports "N" and "P".

Dimensional Data and Weights – LPC Double Acting

Figure 11: Dimensional Data – Double Acting – Sym/Cant

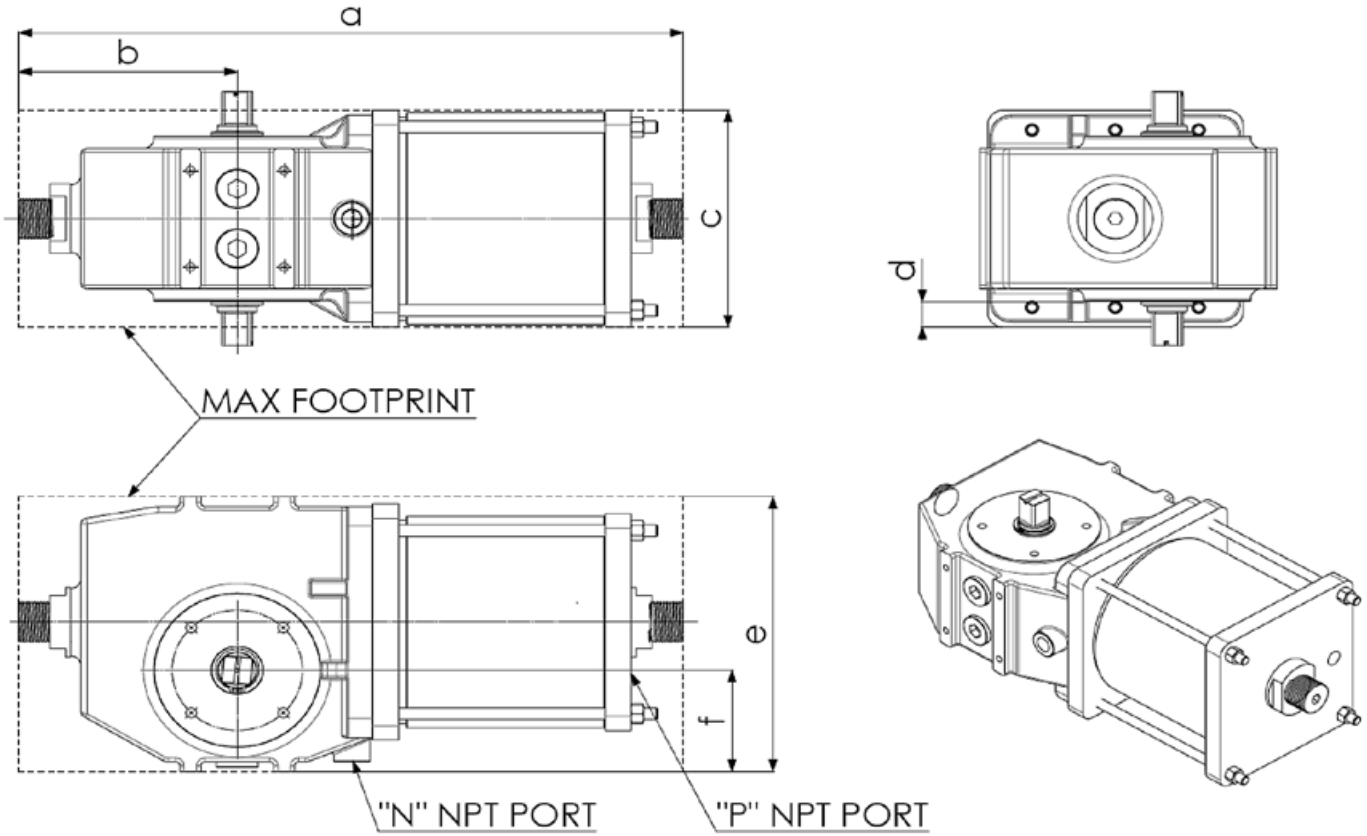

Table 2: LPC Double Acting – Dimensional, Weight and Volume Tables

LPC - Double Acting - Dimensions: mm (in) - Weights: Kg (lbs) - Swept Volumes: l (cu in) - MOT Nm (ft-lb)												
Model	a*	b*	c	d	e	f	"P" NPT PORT	"N" NPT PORT	Weight	Swept volume*		MOT
										Port "P"	Port "N"	
LPC-05X-080Y-DA	512	165	175	18	197	69	1/4"	1/4"	33	0,5	2,8	550
	20,1	6,5	6,9	0,7	7,8	2,7			72	31	171	369
LPC-05X-100Y-DA	512	165	175	18	197	69	1/4"	1/4"	39	0,8	3,1	550
	20,1	6,5	6,9	0,7	7,8	2,7			87	49	189	369
LPC-05X-120Y-DA	512	165	175	18	197	69	1/4"	1/4"	40	1,2	3,5	550
	20,1	6,5	6,9	0,7	7,8	2,7			88	73	214	369
LPC-05X-140Y-DA	512	165	175	18	197	69	1/4"	1/4"	43	1,6	3,9	550
	20,1	6,5	6,9	0,7	7,8	2,7			94	98	238	369
LPC-05X-160Y-DA	512	165	185	23	200	69	1/2"	1/4"	47	2,1	4,4	550
	20,1	6,5	7,3	0,9	7,9	2,7			103	128	269	369
LPC-10X-100Y-DA	616	195	245	37	285	105	1/4"	1/2"	56	0,9	6,7	1600
	24,3	7,7	9,6	1,4	11,2	4,1			123	55	409	1180
LPC-10X-120Y-DA	616	195	245	37	285	105	1/4"	1/2"	60	1,5	7,1	1600
	24,3	7,7	9,6	1,4	11,2	4,1			132	92	433	1180
LPC-10X-140Y-DA	616	195	245	37	285	105	1/4"	1/2"	63	2,1	7,7	1600
	24,3	7,7	9,6	1,4	11,2	4,1			139	128	470	1180
LPC-10X-160Y-DA	616	195	245	37	285	105	1/2"	1/2"	67	2,4	8,3	1600
	24,3	7,7	9,6	1,4	11,2	4,1			148	146	506	1180
LPC-10X-180Y-DA	616	195	245	37	285	105	1/2"	1/2"	73	3,4	9,0	1600
	24,3	7,7	9,6	1,4	11,2	4,1			161	207	549	1180
LPC-10X-200Y-DA	616	195	245	37	285	105	1/2"	1/2"	75	4,2	9,8	1600
	24,3	7,7	9,6	1,4	11,2	4,1			165	256	598	1180
LPC-10X-220Y-DA	616	195	245	37	285	105	1/2"	1/2"	81	5,1	10,7	1600
	24,3	7,7	9,6	1,4	11,2	4,1			179	311	653	1180
LPC-12X-140Y-DA	666	214	243	28	285	101	1/4"	3/4"	82	2,2	9,7	3500
	26,2	8,4	9,6	1,1	11,2	4,0			181	136	601,4	2581
LPC-12X-160Y-DA	666	214	243	28	285	101	1/2"	3/4"	85	2,8	10,3	3500
	26,2	8,4	9,6	1,1	11,2	4,0			188	173,6	638,6	2581
LPC-12X-180Y-DA	666	214	243	28	285	101	1/2"	3/4"	89	3,5	11	3500
	26,2	8,4	9,6	1,1	11,2	4,0			195	217	682	2581
LPC-12X-200Y-DA	666	214	243	28	285	101	1/2"	3/4"	92	4,4	11,8	3500
	26,2	8,4	9,6	1,1	11,2	4,0			203	272,8	731,6	2581
LPC-12X-235Y-DA	666	214	260	36	289	101	1/2"	3/4"	103	6,1	13,3	3500
	26,2	8,4	10,2	1,4	11,4	4,0			227	378,2	824,6	2581
LPC-12X-285Y-DA	661	214	363	88	363	124	1"	3/4"	126	9,0	16	3500
	26,0	8,4	14,3	3,4	14,3	4,9			278	558	992	2581
LPC-12X-335Y-DA	666	214	413	113	413	149	1"	3/4"	148	12,3	19,1	3500
	26,2	8,4	16,3	4,4	16,3	5,8			327	763	1184,2	2581
LPC-14X-180Y-DA	764	252	284	31	316	116	1/2"	3/4"	120	4,1	12,1	5500
	30,1	9,9	11,2	1,2	12,4	4,6			263	254,2	748	4057
LPC-14X-235Y-DA	764	252	284	31	316	116	1/2"	3/4"	133	7	14,7	5500
	30,1	9,9	11,2	1,2	12,4	4,6			293	434	909	4057
LPC-14X-285Y-DA	759	252	371	75	371	121	1"	3/4"	151	10,2	17,6	5500
	29,9	9,9	14,6	2,9	14,6	4,7			334	632,4	1088	4057
LPC-14X-335Y-DA	764	252	413	96	413	142	1"	3/4"	181	14,1	21,1	5500
	30,1	9,9	16,3	3,8	16,3	5,6			399	874,2	1304,4	4057
LPC-14X-360Y-DA	764	252	439	109	439	155	1"	3/4"	193	16,3	23,1	5500
	30,1	9,9	17,3	4,3	17,3	6,1			425	1010,6	1428	4057
LPC-14X-385Y-DA	764	252	465	122	465	168	1"	3/4"	213	18,7	25,2	5500
	30,1	9,9	18,3	4,8	18,3	6,6			469	1159,4	1557,8	4057

(*) Note: Swept Volume and overall dimensions data are referred to actuators with end stops adjusted for 90° of stroke. Refer to Figure for details of Ports "N" and "P".

Dimensional Data and Weights – LPC Single Acting With JL Manual Override

Figure 12: Dimensional Data – Single Acting – Sym/Cant – Fail Close With JL Manual Override

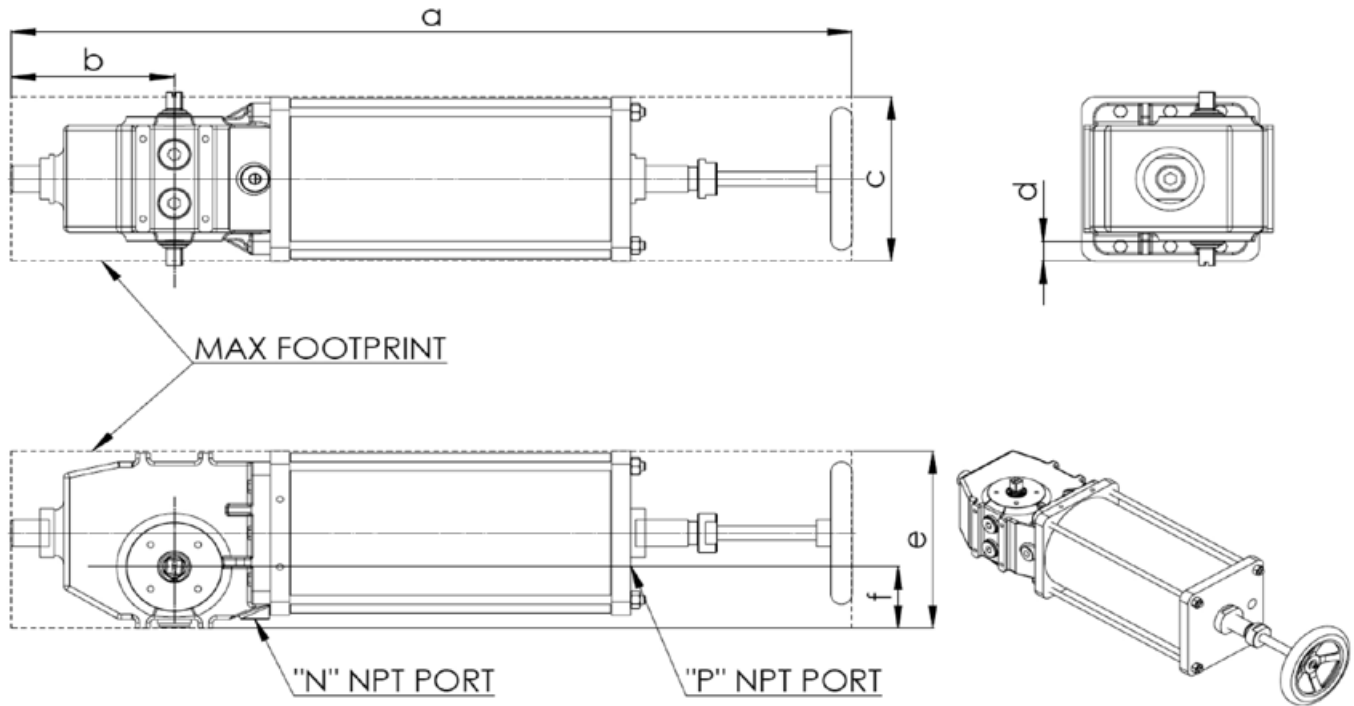

Figure 13: Dimensional Data – Single Acting – Sym/Cant – Fail Open With JL Manual Override

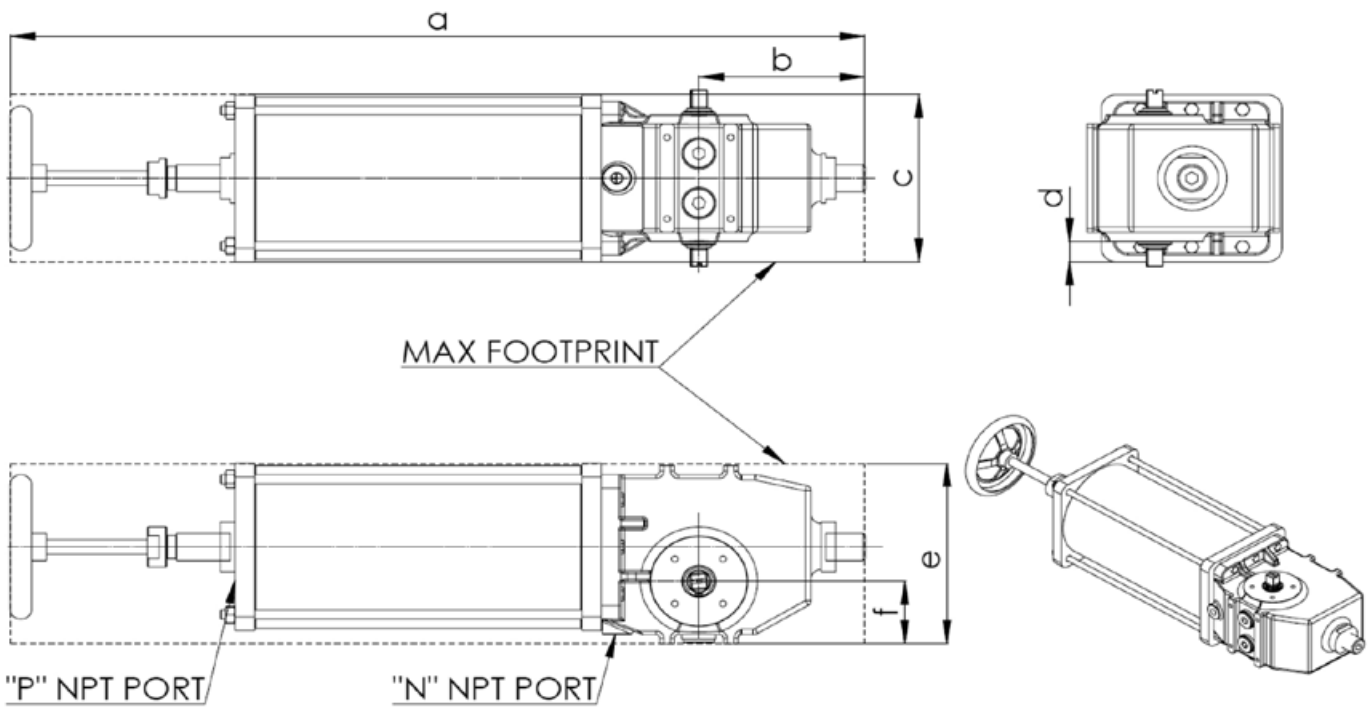



Table 3: LPC Single Acting w/ JL Manual Override – Dimensional, Weight and Volume Tables

LPC - Single Acting - MANUAL OVERRIDE JL - Dimensions: mm (in) - Weights: Kg (lbs) - MOT Nm (ft-lb)											
Model	a*	b*	c	d	e	f	"P" NPT PORT	"N" NPT PORT	Weight	Swept Volume*	MOT
LPC-05X-080Y-SR01-JL	871	173	175	18	197	69	1/4"	1/4"	38	0,5	550
	34,3	6,8	6,9	0,7	7,8	2,7			84	31	369
LPC-05X-080Y-SR02-JL	871	173	175	18	197	69	1/4"	1/4"	39	0,5	550
	34,3	6,8	6,9	0,7	7,8	2,7			86	31	369
LPC-05X-100Y-SR01-JL	871	173	175	18	197	69	1/4"	1/4"	44	0,8	550
	34,3	6,8	6,9	0,7	7,8	2,7			96	49	369
LPC-05X-100Y-SR02-JL	871	173	175	18	197	69	1/4"	1/4"	44	0,8	550
	34,3	6,8	6,9	0,7	7,8	2,7			97	49	369
LPC-05X-100Y-SR03-JL	871	173	175	18	197	69	1/4"	1/4"	45	0,8	550
	34,3	6,8	6,9	0,7	7,8	2,7			98	49	369
LPC-05X-120Y-SR01-JL	871	173	175	18	197	69	1/4"	1/4"	45	1,2	550
	34,3	6,8	6,9	0,7	7,8	2,7			99	73	369
LPC-05X-120Y-SR02-JL	871	173	175	18	197	69	1/4"	1/4"	45	1,2	550
	34,3	6,8	6,9	0,7	7,8	2,7			100	73	369
LPC-05X-120Y-SR03-JL	871	173	175	18	197	69	1/4"	1/4"	46	1,2	550
	34,3	6,8	6,9	0,7	7,8	2,7			101	73	369
LPC-05X-120Y-SR04-JL	871	173	175	18	197	69	1/4"	1/4"	46	1,2	550
	34,3	6,8	6,9	0,7	7,8	2,7			102	73	369
LPC-05X-120Y-SR05-JL	871	173	175	18	197	69	1/4"	1/4"	47	1,2	550
	34,3	6,8	6,9	0,7	7,8	2,7			104	73	369
LPC-05X-140Y-SR01-JL	871	173	175	18	197	69	1/4"	1/4"	48	1,6	550
	34,3	6,8	6,9	0,7	7,8	2,7			107	98	369
LPC-05X-140Y-SR02-JL	871	173	175	18	197	69	1/4"	1/4"	49	1,6	550
	34,3	6,8	6,9	0,7	7,8	2,7			108	98	369
LPC-05X-140Y-SR03-JL	871	173	175	18	197	69	1/4"	1/4"	49	1,6	550
	34,3	6,8	6,9	0,7	7,8	2,7			109	98	369
LPC-05X-140Y-SR04-JL	871	173	175	18	197	69	1/4"	1/4"	50	1,6	550
	34,3	6,8	6,9	0,7	7,8	2,7			110	98	369
LPC-05X-140Y-SR05-JL	871	173	175	18	197	69	1/4"	1/4"	51	1,6	550
	34,3	6,8	6,9	0,7	7,8	2,7			112	98	369
LPC-05X-140Y-SR06-JL	871	173	175	18	197	69	1/4"	1/4"	55	1,6	550
	34,3	6,8	6,9	0,7	7,8	2,7			121	98	369
LPC-05X-160Y-SR01-JL	871	173	185	23	200	69	1/2"	1/4"	54	2,1	550
	34,3	6,8	7,3	0,9	7,9	2,7			119	128	369
LPC-05X-160Y-SR02-JL	871	173	185	23	200	69	1/2"	1/4"	55	2,1	550
	34,3	6,8	7,3	0,9	7,9	2,7			120	128	369
LPC-05X-160Y-SR03-JL	871	173	185	23	200	69	1/2"	1/4"	55	2,1	550
	34,3	6,8	7,3	0,9	7,9	2,7			121	128	369
LPC-05X-160Y-SR04-JL	871	173	185	23	200	69	1/2"	1/4"	56	2,1	550
	34,3	6,8	7,3	0,9	7,9	2,7			122	128	369
LPC-05X-160Y-SR05-JL	871	173	185	23	200	69	1/2"	1/4"	57	2,1	550
	34,3	6,8	7,3	0,9	7,9	2,7			125	128	369
LPC-05X-160Y-SR06-JL	871	173	185	23	200	69	1/2"	1/4"	58	2,1	550
	34,3	6,8	7,3	0,9	7,9	2,7			128	128	369
LPC-10X-100Y-SR01-JL	1093	205	400	114	330	150	1/4"	1/2"	76	1,1	1600
	43,0	8,1	15,7	4,5	13,0	5,9			166	67	1180
LPC-10X-120Y-SR01-JL	1093	205	400	114	330	150	1/4"	1/2"	80	1,5	1600
	43,0	8,1	15,7	4,5	13,0	5,9			175	92	1180
LPC-10X-120Y-SR02-JL	1093	205	400	114	330	150	1/4"	1/2"	82	1,5	1600
	43,0	8,1	15,7	4,5	13,0	5,9			180	92	1180
LPC-10X-140Y-SR01-JL	1093	205	400	114	330	150	1/4"	1/2"	84	2,1	1600
	43,0	8,1	15,7	4,5	13,0	5,9			186	128	1180
LPC-10X-140Y-SR02-JL	1093	205	400	114	330	150	1/4"	1/2"	87	2,1	1600
	43,0	8,1	15,7	4,5	13,0	5,9			191	128	1180
LPC-10X-140Y-SR03-JL	1136	205	400	114	330	150	1/4"	1/2"	89	2,1	1600
	44,7	8,1	15,7	4,5	13,0	5,9			195	128	1180
LPC-10X-160Y-SR01-JL	1093	205	400	114	330	150	1/2"	1/2"	87	2,7	1600
	43,0	8,1	15,7	4,5	13,0	5,9			192	165	1180
LPC-10X-160Y-SR02-JL	1093	205	400	114	330	150	1/2"	1/2"	88	2,7	1600
	43,0	8,1	15,7	4,5	13,0	5,9			195	165	1180
LPC-10X-160Y-SR03-JL	1136	205	400	114	330	150	1/2"	1/2"	90	2,7	1600
	44,7	8,1	15,7	4,5	13,0	5,9			199	165	1180
LPC-10X-160Y-SR04-JL	1136	205	400	114	330	150	1/2"	1/2"	93	2,7	1600
	44,7	8,1	15,7	4,5	13,0	5,9			205	165	1180
LPC-10X-160Y-SR05-JL	1179	205	400	114	330	150	1/2"	1/2"	94	2,7	1600
	46,4	8,1	15,7	4,5	13,0	5,9			208	165	1180
LPC-10X-180Y-SR01-JL	1093	205	400	114	330	150	1/2"	1/2"	98	3,4	1600
	43,0	8,1	15,7	4,5	13,0	5,9			216	207	1180
LPC-10X-180Y-SR02-JL	1093	205	400	114	330	150	1/2"	1/2"	99	3,4	1600
	43,0	8,1	15,7	4,5	13,0	5,9			219	207	1180
LPC-10X-180Y-SR03-JL	1136	205	400	114	330	150	1/2"	1/2"	101	3,4	1600
	44,7	8,1	15,7	4,5	13,0	5,9			222	207	1180
LPC-10X-180Y-SR04-JL	1136	205	400	114	330	150	1/2"	1/2"	103	3,4	1600
	44,7	8,1	15,7	4,5	13,0	5,9			228	207	1180
LPC-10X-180Y-SR05-JL	1179	205	400	114	330	150	1/2"	1/2"	105	3,4	1600
	46,4	8,1	15,7	4,5	13,0	5,9			231	207	1180

(*) Note: Swept Volume and overall dimensions data are referred to actuators with end stops adjusted for 90° of stroke. Refer to Figure for details of Ports "N" and "P".

LPC - Single Acting - MANUAL OVERRIDE JL - Dimensions: mm (in) - Weights: Kg (lbs) - MOT Nm (ft-lb)											
Model	a*	b*	c	d	e	f	"P" NPT PORT	"N" NPT PORT	Weight	Swept Volume*	MOT
LPC-12X-335Y-SR01-JL	1137	214	413	113	413	149	1"	3/4"	184	12,3	3500
	44,8	8,4	16,3	4,4	16,3	5,8			406	763	2581
LPC-12X-335Y-SR02-JL	1137	214	413	113	413	149	1"	3/4"	187	12,3	3500
	44,8	8,4	16,3	4,4	16,3	5,8			413	763	2581
LPC-12X-335Y-SR03-JL	1248	214	413	113	413	149	1"	3/4"	198	12,3	3500
	49,1	8,4	16,3	4,4	16,3	5,8			437	763	2581
LPC-12X-335Y-SR04-JL	1248	214	413	113	413	149	1"	3/4"	205	12,3	3500
	49,1	8,4	16,3	4,4	16,3	5,8			452	763	2581
LPC-12X-335Y-SR05-JL	1258	214	600	206	507	242	1"	3/4"	206	12,3	3500
	49,5	8,4	23,6	8,1	19,9	9,5			455	763	2581
LPC-12X-335Y-SR06-JL	1258	214	600	206	507	242	1"	3/4"	216	12,3	3500
	49,5	8,4	23,6	8,1	19,9	9,5			476	763	2581
LPC-14X-180Y-SR01-JL	1344	250	400	89	335	135	1/2"	3/4"	162	4,1	5500
	52,9	9,8	15,7	3,5	13,2	5,3			357	254	4057
LPC-14X-235Y-SR01-JL	1344	250	400	89	335	135	1/2"	3/4"	178	7	5500
	52,9	9,8	15,7	3,5	13,2	5,3			393	434	4057
LPC-14X-235Y-SR02-JL	1344	250	400	89	335	135	1/2"	3/4"	182	7	5500
	52,9	9,8	15,7	3,5	13,2	5,3			402	434	4057
LPC-14X-235Y-SR03-JL	1354	250	600	189	435	235	1/2"	3/4"	193	7	5500
	53,3	9,8	23,6	7,4	17,1	9,3			425	434	4057
LPC-14X-285Y-SR01-JL	1339	250	400	89	386	135	1"	3/4"	205	10,2	5500
	52,7	9,8	15,7	3,5	15,2	5,3			452	632	4057
LPC-14X-285Y-SR02-JL	1339	250	400	89	386	135	1"	3/4"	209	10,2	5500
	52,7	9,8	15,7	3,5	15,2	5,3			460	632	4057
LPC-14X-285Y-SR03-JL	1349	250	600	189	486	235	1"	3/4"	219	10,2	5500
	53,1	9,8	23,6	7,4	19,1	9,3			483	632	4057
LPC-14X-285Y-SR04-JL	1324	250	600	189	486	235	1"	3/4"	194	10,2	5500
	52,1	9,8	23,6	7,4	19,1	9,3			429	632	4057
LPC-14X-335Y-SR01-JL	1344	250	413	96	413	142	1"	3/4"	237	14,1	5500
	52,9	9,8	16,3	3,8	16,3	5,6			523	874	4057
LPC-14X-335Y-SR02-JL	1344	250	413	96	413	142	1"	3/4"	241	14,1	5500
	52,9	9,8	16,3	3,8	16,3	5,6			532	874	4057
LPC-14X-335Y-SR03-JL	1354	250	600	189	507	235	1"	3/4"	252	14,1	5500
	53,3	9,8	23,6	7,4	19,9	9,3			555	874	4057
LPC-14X-335Y-SR04-JL	1329	250	600	189	507	235	1"	3/4"	226	14,1	5500
	52,3	9,8	23,6	7,4	19,9	9,3			499	874	4057
LPC-14X-335Y-SR05-JL	1339	250	900	339	657	385	1"	3/4"	258	14,1	5500
	52,7	9,8	35,4	13,3	25,8	15,2			568	874	4057
LPC-14X-335Y-SR06-JL	1339	250	900	339	657	385	1"	3/4"	278	14,1	5500
	52,7	9,8	35,4	13,3	25,8	15,2			614	874	4057
LPC-14X-360Y-SR01-JL	1344	250	439	109	439	155	1"	3/4"	257	16,3	5500
	52,9	9,8	17,3	4,3	17,3	6,1			566	1011	4057
LPC-14X-360Y-SR02-JL	1344	250	439	109	439	155	1"	3/4"	261	16,3	5500
	52,9	9,8	17,3	4,3	17,3	6,1			574	1011	4057
LPC-14X-360Y-SR03-JL	1354	250	600	189	520	235	1"	3/4"	271	16,3	5500
	53,3	9,8	23,6	7,4	20,5	9,3			597	1011	4057
LPC-14X-360Y-SR04-JL	1329	250	600	189	520	235	1"	3/4"	246	16,3	5500
	52,3	9,8	23,6	7,4	20,5	9,3			541	1011	4057
LPC-14X-360Y-SR05-JL	1339	250	900	339	670	385	1"	3/4"	275	16,3	5500
	52,7	9,8	35,4	13,3	26,4	15,2			605	1011	4057
LPC-14X-360Y-SR06-JL	1339	250	900	339	670	385	1"	3/4"	294	16,3	5500
	52,7	9,8	35,4	13,3	26,4	15,2			647	1011	4057
LPC-14X-385Y-SR01-JL	1344	250	465	122	465	168	1"	3/4"	275	18,7	5500
	52,9	9,8	18,3	4,8	18,3	6,6			607	1159	4057
LPC-14X-385Y-SR02-JL	1344	250	465	122	465	168	1"	3/4"	279	18,7	5500
	52,9	9,8	18,3	4,8	18,3	6,6			615	1159	4057
LPC-14X-385Y-SR03-JL	1354	250	600	189	533	235	1"	3/4"	279	18,7	5500
	53,3	9,8	23,6	7,4	21,0	9,3			615	1159	4057
LPC-14X-385Y-SR04-JL	1329	250	600	189	533	235	1"	3/4"	290	18,7	5500
	52,3	9,8	23,6	7,4	21,0	9,3			639	1159	4057
LPC-14X-385Y-SR05-JL	1339	250	900	339	683	385	1"	3/4"	264	18,7	5500
	52,7	9,8	35,4	13,3	26,9	15,2			582	1159	4057
LPC-14X-385Y-SR06-JL	1334	250	900	339	683	385	1"	3/4"	295	18,7	5500
	52,5	9,8	35,4	13,3	26,9	15,2			651	1159	4057
LPC-14X-435Y-SR01-JL	1344	250	526	152	526	198	1"	1"	326	23,8	5500
	52,9	9,8	20,7	6,0	20,7	7,8			719	1476	4057
LPC-14X-435Y-SR02-JL	1344	250	526	152	526	198	1"	1"	330	23,8	5500
	52,9	9,8	20,7	6,0	20,7	7,8			728	1476	4057
LPC-14X-435Y-SR03-JL	1354	250	600	189	563	235	1"	1"	341	23,8	5500
	53,3	9,8	23,6	7,4	22,2	9,3			751	1476	4057
LPC-14X-435Y-SR04-JL	1329	250	600	189	563	235	1"	1"	314	23,8	5500
	52,3	9,8	23,6	7,4	22,2	9,3			693	1476	4057
LPC-14X-435Y-SR05-JL	1339	250	900	339	713	385	1"	1"	346	23,8	5500
	52,7	9,8	35,4	13,3	28,1	15,2			762	1476	4057
LPC-14X-435Y-SR06-JL	1339	250	900	339	713	385	1"	3/4"	362	23,8	5500
	52,7	9,8	35,4	13,3	28,1	15,2			799	1476	4057

(*) Note: Swept Volume and overall dimensions data are referred to actuators with end stops adjusted for 90° of stroke. Refer to Figure for details of Ports "N" and "P".

Dimensional Data and Weights – LPC Double Acting With JL Manual Override

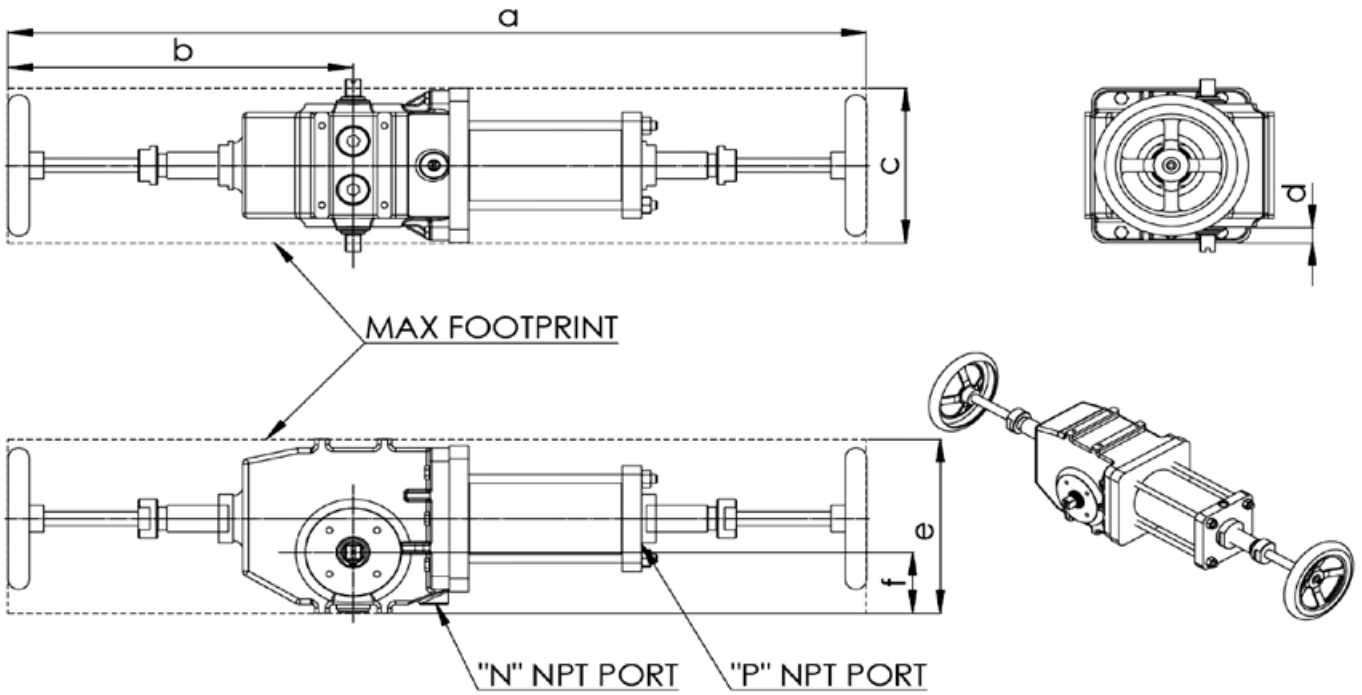



Table 4: LPC Double Acting w/ JL Manual Override – Dimensional, Weight and Volume Tables

LPC - Double Acting - MANUAL OVERRIDE JL - Dimensions: mm (in) - Weights: Kg (lbs) - MOT Nm (ft-lb)												
Model	a*	b*	c	d	e	f	"P" NPT PORT	"N" NPT PORT	Weight	Swept Volume*		MOT
										Port "P"	Port "N"	
LPC-05X-080Y-DA-JL	886	356	175	18	197	69	1/4"	1/4"	35	0,5	2,8	550
	34,9	14,0	6,9	0,7	7,8	2,7			76	31	171	369
LPC-05X-100Y-DA-JL	886	356	175	18	197	69	1/4"	1/4"	41	0,8	3,1	550
	34,9	14,0	6,9	0,7	7,8	2,7			91	49	189	369
LPC-05X-120Y-DA-JL	886	356	175	18	197	69	1/4"	1/4"	42	1,2	3,5	550
	34,9	14,0	6,9	0,7	7,8	2,7			93	73	214	369
LPC-05X-140Y-DA-JL	886	356	175	18	197	69	1/4"	1/4"	45	1,6	3,9	550
	34,9	14,0	6,9	0,7	7,8	2,7			99	98	238	369
LPC-05X-160Y-DA-JL	886	356	185	23	200	69	1/2"	1/4"	49	2,1	4,4	550
	34,9	14,0	7,3	0,9	7,9	2,7			108	128	269	369
LPC-10X-100Y-DA-JL	1130	452	400	114	400	150	1/4"	1/2"	71	0,9	6,7	1600
	44,5	17,8	15,7	4,5	15,7	5,9			156	55	409	1180
LPC-10X-120Y-DA-JL	1130	452	400	114	400	150	1/4"	1/2"	75	1,5	7,1	1600
	44,5	17,8	15,7	4,5	15,7	5,9			165	92	433	1180
LPC-10X-140Y-DA-JL	1130	452	400	114	400	150	1/4"	1/2"	78	2,1	7,7	1600
	44,5	17,8	15,7	4,5	15,7	5,9			172	128	470	1180
LPC-10X-160Y-DA-JL	1130	452	400	114	400	150	1/2"	1/2"	82	2,4	8,3	1600
	44,5	17,8	15,7	4,5	15,7	5,9			181	146	506	1180
LPC-10X-180Y-DA-JL	1130	452	400	114	400	150	1/2"	1/2"	88	3,4	9,0	1600
	44,5	17,8	15,7	4,5	15,7	5,9			194	207	549	1180
LPC-10X-200Y-DA-JL	1130	452	400	114	400	150	1/2"	1/2"	90	4,2	9,8	1600
	44,5	17,8	15,7	4,5	15,7	5,9			198	256	598	1180
LPC-10X-220Y-DA-JL	1130	452	400	114	400	150	1/2"	1/2"	96	5,1	10,7	1600
	44,5	17,8	15,7	4,5	15,7	5,9			212	311	653	1180
LPC-12X-140Y-DA-JL	1086	424	400	106	400	142	1/4"	3/4"	92	2,2	9,7	3500
	42,7	16,7	15,7	4,2	15,7	5,6			203	134	592	2581
LPC-12X-160Y-DA-JL	1086	424	400	106	400	142	1/2"	3/4"	95	2,8	10,3	3500
	42,7	16,7	15,7	4,2	15,7	5,6			210	171	629	2581
LPC-12X-180Y-DA-JL	1086	424	400	106	400	142	1/2"	3/4"	99	3,5	11	3500
	42,7	16,7	15,7	4,2	15,7	5,6			217	214	671	2581
LPC-12X-200Y-DA-JL	1086	424	400	106	400	142	1/2"	3/4"	102	4,4	11,8	3500
	42,7	16,7	15,7	4,2	15,7	5,6			225	269	720	2581
LPC-12X-235Y-DA-JL	1086	424	400	106	400	142	1/2"	3/4"	113	6,1	13,3	3500
	42,7	16,7	15,7	4,2	15,7	5,6			249	372	812	2581
LPC-12X-285Y-DA-JL	1081	424	400	106	400	142	1"	3/4"	136	9	16	3500
	42,5	16,7	15,7	4,2	15,7	5,6			300	549	976	2581
LPC-12X-335Y-DA-JL	1106	434	600	206	600	242	1"	3/4"	158	12,3	19,1	3500
	43,5	17,1	23,6	8,1	23,6	9,5			349	751	1166	2581
LPC-14X-180Y-DA-JL	1198	469	400	89	400	135	1/2"	3/4"	120	4,1	12,1	5500
	47,2	18,5	15,7	3,5	15,7	5,3			263	250	738	4057
LPC-14X-235Y-DA-JL	1198	469	400	89	400	135	1/2"	3/4"	133	7	14,7	5500
	47,2	18,5	15,7	3,5	15,7	5,3			293	427	897	4057
LPC-14X-285Y-DA-JL	1193	469	400	89	400	135	1"	3/4"	151	10,2	17,6	5500
	47,0	18,5	15,7	3,5	15,7	5,3			334	622	1074	4057
LPC-14X-335Y-DA-JL	1218	479	600	189	600	235	1"	3/4"	181	14,1	21,1	5500
	48,0	18,9	23,6	7,4	23,6	9,3			399	860	1288	4057
LPC-14X-360Y-DA-JL	1218	479	600	189	600	235	1"	3/4"	193	16,3	23,1	5500
	48,0	18,9	23,6	7,4	23,6	9,3			425	995	1410	4057
LPC-14X-385Y-DA-JL	1218	479	600	189	600	235	1"	3/4"	213	18,7	25,2	5500
	48,0	18,9	23,6	7,4	23,6	9,3			469	1141	1538	4057
LPC-14X-435Y-DA-JL	1218	479	600	189	600	235	1"	1"	256	23,8	29,9	5500
	48,0	18,9	23,6	7,4	23,6	9,3			565	1476	1848	4057

(*) Note: Swept Volume and overall dimensions data are referred to actuators with end stops adjusted for 90° of stroke. Refer to Figure for details of Ports "N" and "P".

Mounting Interface Coupling Dimensions and Standard NAMUR VDE/VDI 3845 Kit Details (available as optional item, upon request)

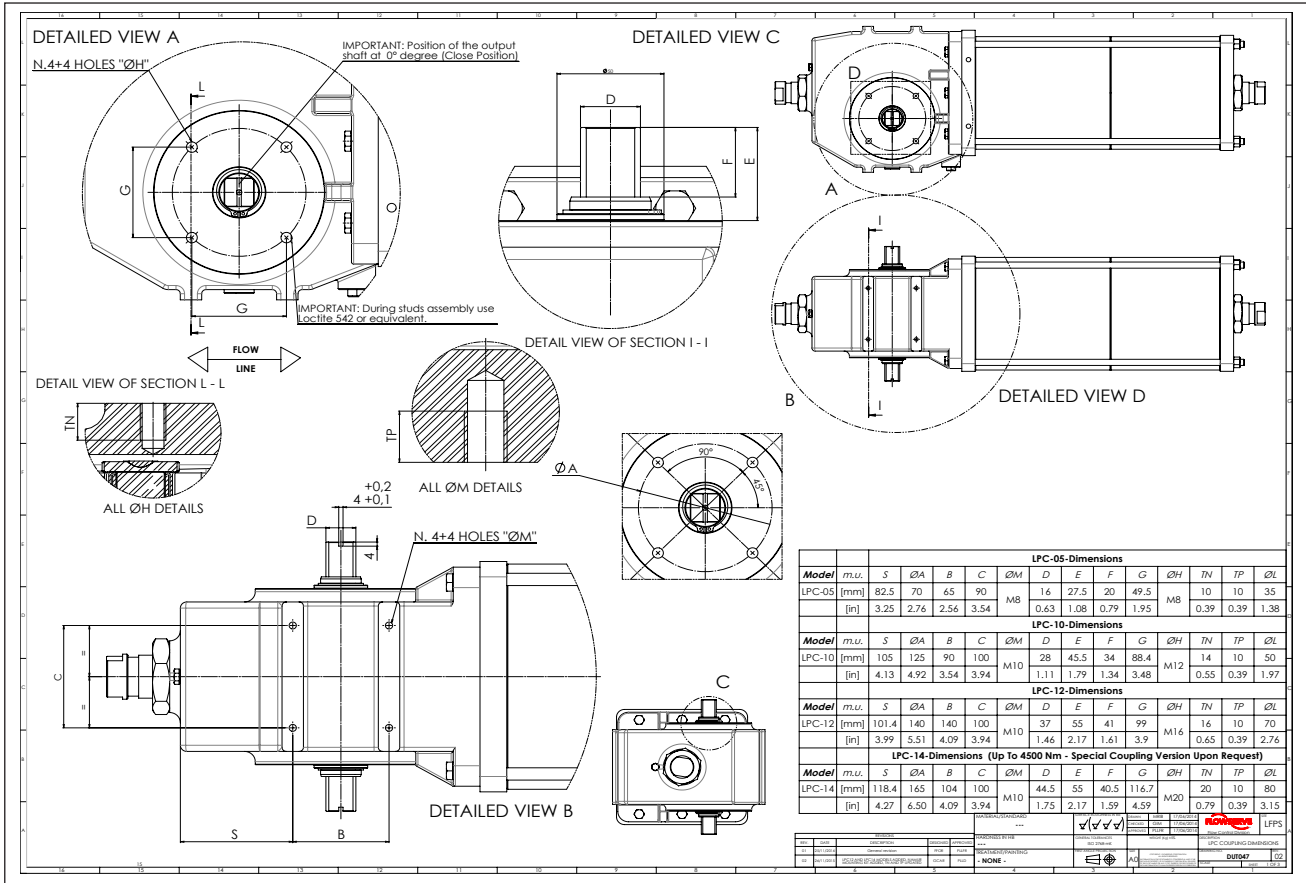

Figure 15: Coupling Details of LPC-05, LPC-10, LPC-12 Symmetric/Canted (also LPC-14 could be supplied with this coupling interface, but as special version and upon request)

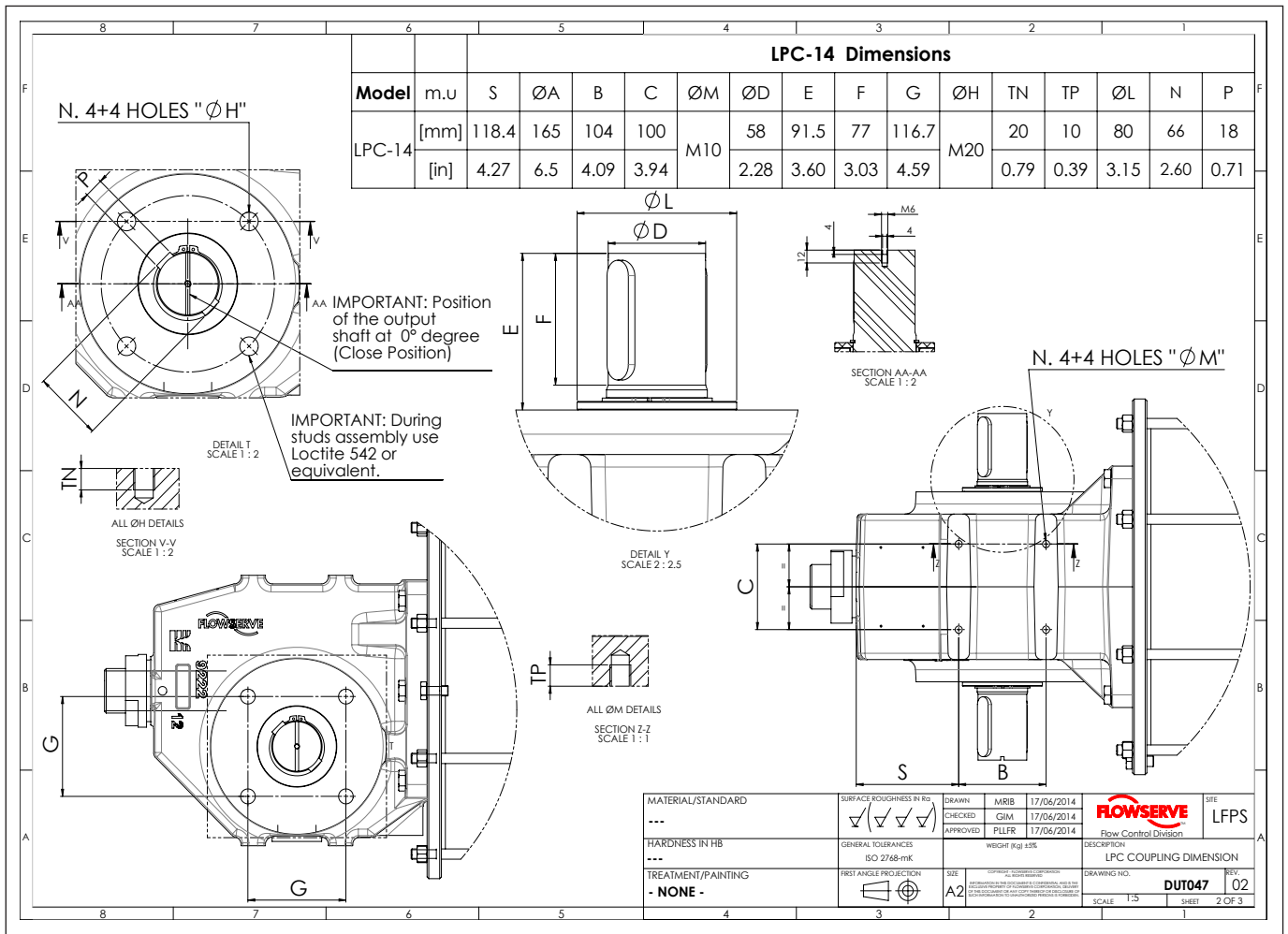

Figure 16: LPC-14 Coupling Details – Symmetric/Canted

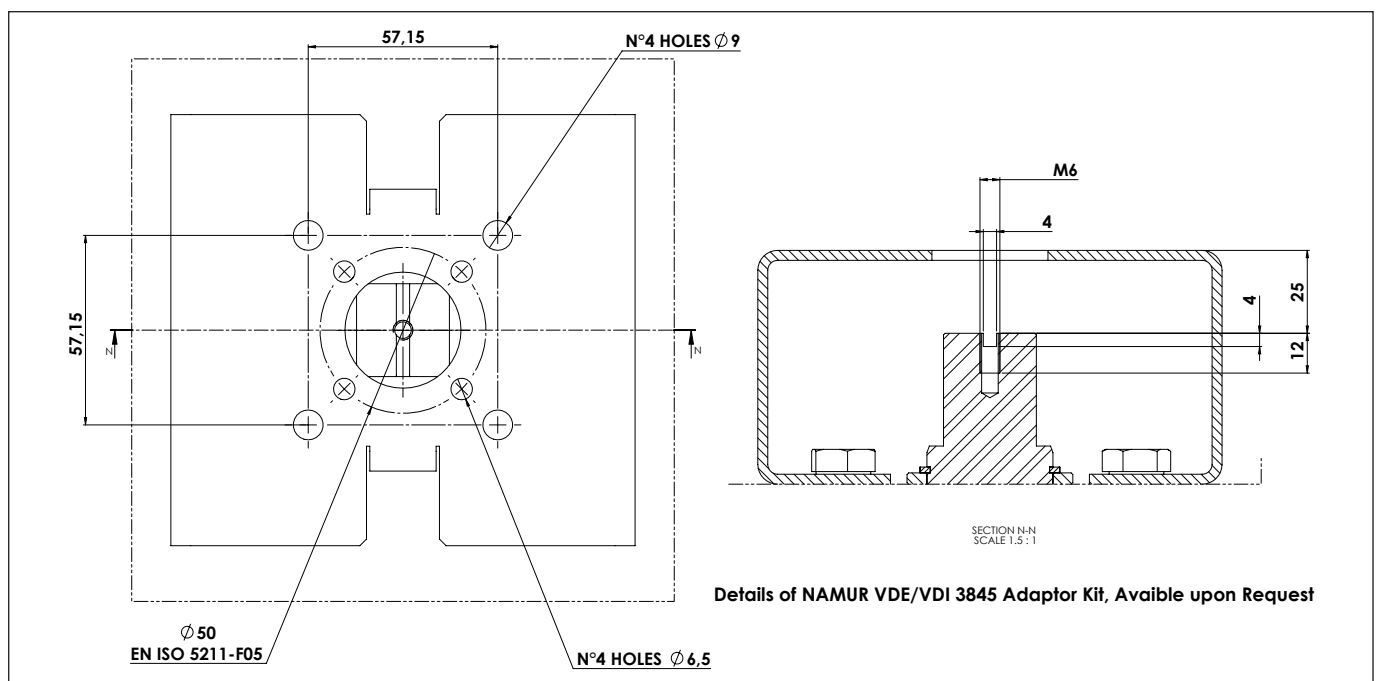
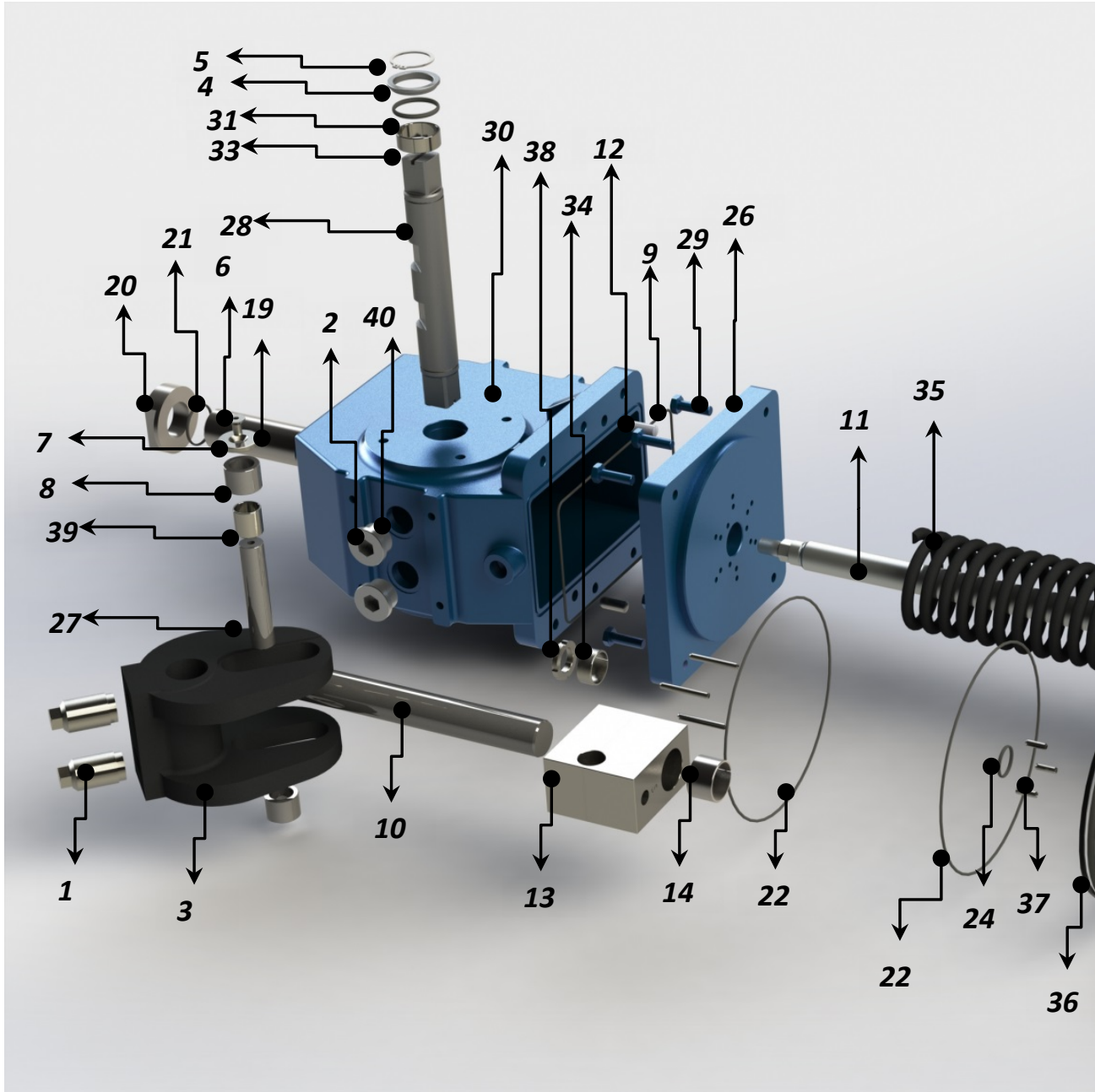

Figure 17: Details of Namur Vde/Vdi 3845 Adaptor Kit, Available Upon Request

Service Kits

Figure 18: LPC Actuator Spring Return and Double Acting – Exploded Views



Number	Description	Qty.	Spare Parts*
1	Grub Screw	2	
2	Plug	2	
3	Scotch Yoke	1	
4	Bushing	2	
5	Retaining Ring	2	
6 ⁴	Screw	2	
6 ⁵	Retaining Ring	2	
7	Washer	2	

Number	Description	Qty.	Spare Parts*
8	Roller Bearing	2	
9	O-Ring	1	X •
10	Guide Bar	1	
11	Piston Rod	1	
12	Pin	2	
13	Guide Block	1	
14	Bushing	2	
15	Piston	1	

Number	Description	Qty.	Spare Parts*
16 ⁵	Tie Rod	4 (8)	
17	Spring Can	2	
18 ⁵	Hex Nut	4 (8)	
19	Stop Bolt	2	
20	Hex Nut	2	
21	O-Ring	2	X •
22 ¹	O-Ring	3 (2)	X •
23	End Flange	1	

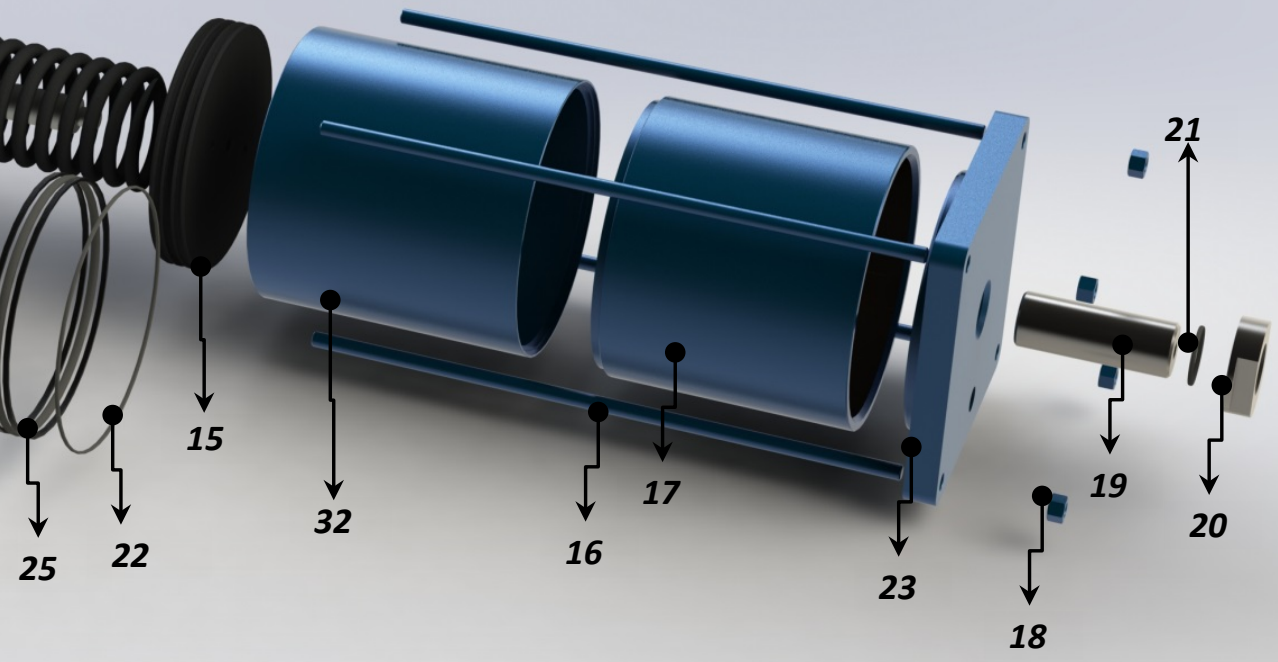
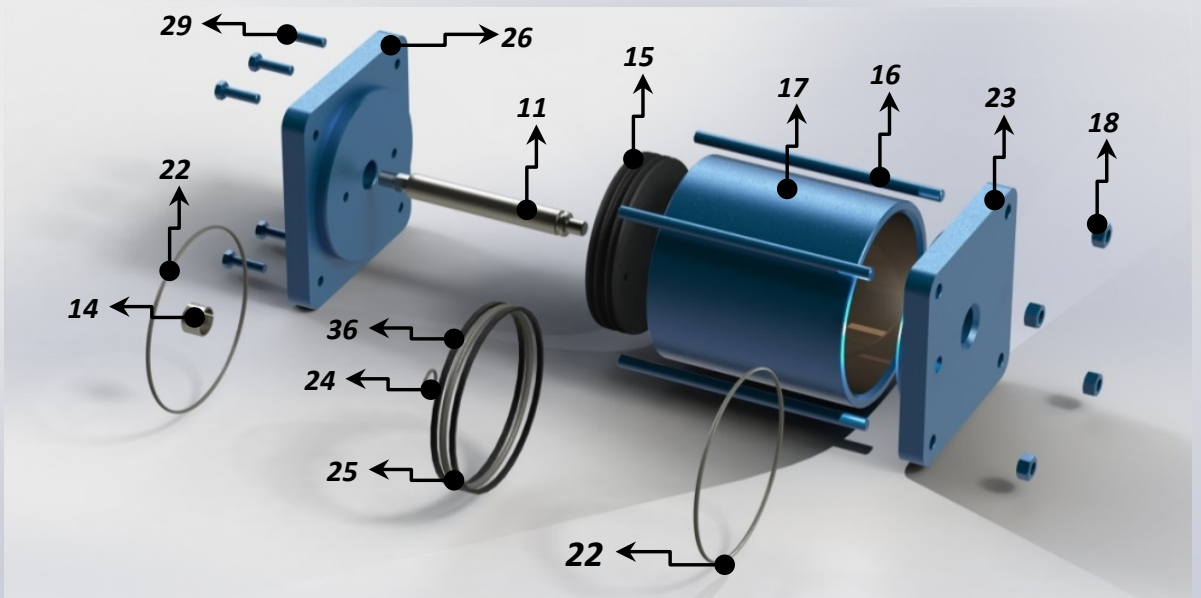

Number	Description	Qty.	Spare Parts*
24	O-Ring	1	X •
25	O-Ring	1	X •
26	Adaptor Flange	1	
27	Yoke Pin	1	
28	Output Shaft	1	
29	Screw	6	
30	Housing	1	
31 ²	O-Ring	2	X •
32	Spacer	1	

Number	Description	Qty.	Spare Parts*
33	Du Bushing	2	
34	Bushing	1	
35	Spring	1	
36	Guide Ring	2	X •
37	Bar Pin	6	
38	Spanner Nut	1	
39	Bushing	2	
40 ³	O-Ring	2	X •

Notes:

* Standard maintenance spare parts for on/off applications

X Spare parts that can be replaced

• Spare parts that can be replaced without removing the actuator from the valve

1: Quantity of Item 22 is 2 for Double Acting actuators and 3 for Single Acting actuators

2: Only the O-rings on the top of the actuator can be replaced without removing the actuator from the valve

3: Only for LPC-12 and LPC-14 models

4: Only for LPC-05 and LPC-10 models

5: Quantity variable depending on cylinder size



**Flowserve Limitorque
Fluid Power Systems
Product Sales**
Via Rio Vallone 17
20883 Mezzago (MB), Italy
Phone: +39 039 62060 1
Fax: +39 039 62060 213
Email: lfpsinfo@flowserve.com

**Flowserve Limitorque
Fluid Power Systems
Manufacturing and Operations**
Via Rio Vallone 17
20883 Mezzago (MB), Italy
Phone: +39 039 62060 1
Fax: +39 039 62060 213
Email: lfpsinfo@flowserve.com

**Flowserve Limitorque
Fluid Power Systems
Research and Development**
Via Belizzi 40/42
29122 Piacenza (PC), Italy
Email: lfpsinfo@flowserve.com

FCD LFENTB0002-01-A4 Printed in USA. May 2016 © 2016 Flowserve Corporation.

To find your local Flowserve representative

or for more information about Flowserve Corporation,
visit www.flowserve.com or call USA 1 800 225 6989

Flowserve Corporation has established industry leadership in the design and manufacture of its products. When properly selected, this Flowserve product is designed to perform its intended function safely during its useful life. However, the purchaser or user of Flowserve products should be aware that Flowserve products might be used in numerous applications under a wide variety of industrial service conditions. Although Flowserve can (and often does) provide general guidelines, it cannot provide specific data and warnings for all possible applications. The purchaser/user must therefore assume the ultimate responsibility for the proper sizing and selection, installation, operation, and maintenance of Flowserve products. The purchaser/user should read and understand the Installation Operation Maintenance (IOM) instructions included with the product, and train its employees and contractors in the safe use of Flowserve products in connection with the specific application.

While the information and specifications contained in this literature are believed to be accurate, they are supplied for informative purposes only and should not be considered certified or as a guarantee of satisfactory results by reliance thereon. Nothing contained herein is to be construed as a warranty or guarantee, express or implied, regarding any matter with respect to this product. Because Flowserve is continually improving and upgrading its product design, the specifications, dimensions and information contained herein are subject to change without notice. Should any question arise concerning these provisions, the purchaser/user should contact Flowserve Corporation at any one of its worldwide operations or offices.

© 2016 Flowserve Corporation, Irving, Texas, USA. Flowserve is a registered trademark of Flowserve Corporation.