

Fisher™ CV500 Rotary Globe Control Valve

The Fisher CV500 Cam Vee-Ball™ control valve combines the rangeability of the cammed-segmented V-notched ball, with the inherent ruggedness found in the V500 heavy duty bearings, seals and body. This combination provides a balance of erosion resistance and pressure control for gas and liquids. The unrestricted, straight-through flow design provides high capacity for gas, steam, liquids, or fibrous slurries. The flanged valve features streamlined flow passages, rugged metal trim components, and a self-centering seat ring (figures 1 and 2).

With these components, the CV500 valve, designed for throttling or on-off applications, combines globe valve ruggedness with the efficiency of a rotary valve. Matched with a Fisher power or manual actuator, the CV500 valve dependably controls fluids in many process industries.

Unless otherwise noted, all NACE references are to NACE MR0175-2002.

Features

- **Excellent Flow Characteristic**—Precise contouring of V-notch ball provides a modified equal percentage flow characteristic.
- **High Capacity**—Unrestricted, straight-through, flow design provides greater capacity than many conventional globe and rotary eccentric plug valves.
- **Long Seat Life**—The V-notch ball cams into and out of the seat minimizing contact with the seat ring for reduced wear and friction (figure 3). V-notch ball doesn't contact seat during throttling operation. S31600 (316 stainless steel) or R30006 (Alloy 6) seat ring has two shutoff surfaces and can be easily reversed, reducing downtime.



X0189

Fisher CV500 VALVE WITH 2052 ACTUATOR AND FIELDVUE™ DVC6200 DIGITAL VALVE CONTROLLER

- **One-Piece Body**—Valve body is cast in one piece. There are no body gaskets to leak as a result of pipeline stresses.
- **Operational Versatility**—Self-centering seat ring and rugged V-notch ball allow forward or reverse flow with tight shutoff in either flow direction.
- **Easy Installation**—Integral valve flanges mate with many different classes of pipeline flanges, satisfying a variety of piping requirements. Flanges eliminate exposed line flange bolting, shorten alignment and installation time, and promote secure valve installations and piping integrity.

(continued on page 3)

Specifications

Available Configuration

Flanged valve body assembly with reversible⁽¹⁾ metal seat ring and splined shaft. See tables 2 and 3.

Valve Sizes

NPS ■ 3, ■ 4, ■ 6, ■ 8, ■ 10, and ■ 12.
DN 80, 100, 150, 200, 250 and 300 are also available.

End Connection Style and Rating

■ Raised-face flanges or ■ ring-type joint flanges (ASME B16.5). Valve bodies with EN PN10 through PN100 flanges also available. See tables 2 and 3 for ASME and EN availability.

Maximum Inlet Pressure⁽²⁾

Consistent with applicable ASME or EN flange ratings

Maximum Pressure Drops⁽²⁾

See table 4 for both forward and reverse flow pressure drops

Shutoff Classification

Class IV per ANSI/FCI 70-2 and IEC 60534-4, (0.01% of valve capacity at full travel) for either flow direction

Construction Materials

See table 5

Material Temperature Capability⁽²⁾

See table 5

Flow Characteristic

Modified equal percentage

Flow Direction

- Forward (normal) flow is into the convex side of the V-notch ball
- Bidirectional flow is into either side of the V-notch ball

Flow Coefficients

See Fisher Catalog 12

Flow Coefficient Ratio⁽³⁾

200 to 1

Actuator Mounting

■ Right-hand or ■ left-hand as viewed from the upstream side of the valve.

Mounting position depends on the desired open valve position and flow direction required by operating conditions. For more information, see the Installation section.

Valve V-Notch Ball Rotation

Counterclockwise to close (when viewed from the actuator side of the valve body) through 90 degrees of V-notch ball rotation

Valve Body/Actuator Action

With diaphragm or piston rotary actuator, field-reversible between

- push-down-to-close (extending actuator rod closes valve body) and
- push-down-to-open (extending actuator rod opens valve body)

Packing Constructions

PTFE V-Ring: With one carbon-filled PTFE conductive packing ring in ■ single, ■ double, or ■ leak-off arrangements

Braided PTFE Composition and Graphite Ribbon: With one graphited composition conductive packing ring in ■ single, ■ double, or ■ leak-off arrangements

Graphite Ribbon Packing Rings: In ■ single, ■ double, or ■ leak-off arrangements

ENVIRO-SEAL™: ■ PTFE or ■ Graphite in single arrangements

Approximate Weights

See table 1

Dimensions

See figure 4; face-to-face dimensions conform to ISA S75.04. IEC 60534-3-2 face-to-face dimensions are equivalent to S75.04 face-to-face dimensions.

Options

- Sealed bearing constructions, ■ purged bearings

1. The reversible seat is not available in every trim material. Consult your [Emerson sales office](#) or Local Business Partner.
2. The pressure or temperature limits in the referenced tables or figures, and in any applicable code limitation, should not be exceeded.
3. Ratio of maximum flow coefficient to minimum usable flow coefficient. May also be called rangeability.

Table 1. Approximate Weights

VALVE SIZE, NPS	FLANGED		
	CL150	CL300	CL600
DN	kg		
80	19	24	26
100	36	42	50
150	54	69	93
200	79	98	135
250	---	208	---
300	---	253	---
NPS	Pounds		
3	42	52	57
4	79	93	111
6	120	152	204
8	175	217	298
10	---	458	---
12	---	558	---

Table 2. Valve Size, ASME Ratings, and Flange Compatibility

VALVE SIZE, NPS	ASME FLANGED		
	CL150	CL300	CL600
3	X	X	X
4	X	X	X
6	X	X	X
8	X	X	X
10	---	X	---
12	---	X	---

X indicates availability.

Figure 1. Detail of Seat Ring Design

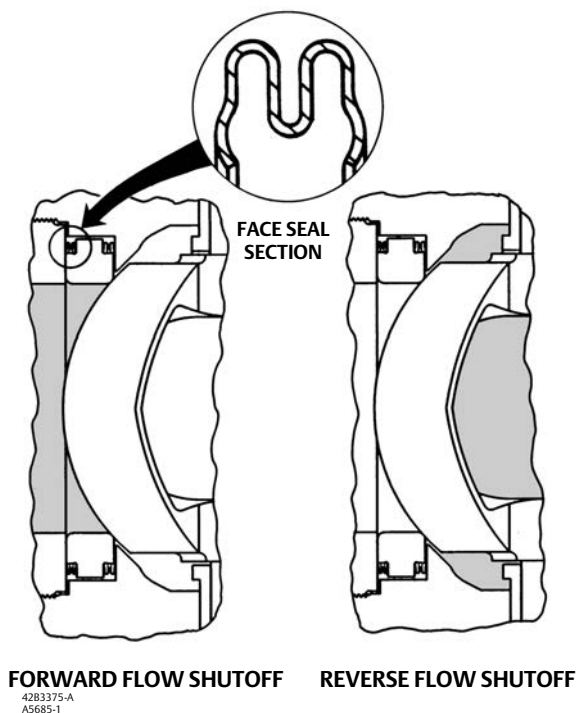

Features (continued)

- **Simple Assembly and Maintenance**—No special orientation, precision clamping or repetitive centering of V-notch ball and seat ring is required when tightening the retainer, promoting accurate alignment and easy assembly.
- **Sour Service Capability**—Trim and bolting materials are available for applications handling sour fluids and gases. These constructions comply with the requirements of NACE MR0175-2002.
- **Rugged Construction**—Durable, solid metal seat ring and ball shut off tightly. Oversized shaft diameters and rugged trim parts allow high pressure drops.
- **Reliable Performance**—The seat ring design (figure 1) self-centers, self-laps, and dynamically aligns with V-notch ball, giving superior cycle life. Optional sealed metal bearings help prevent particle buildup and valve shaft seizure in severe applications.

Figure 2. Sectionals of Fisher CV500 Rotary Control Valves

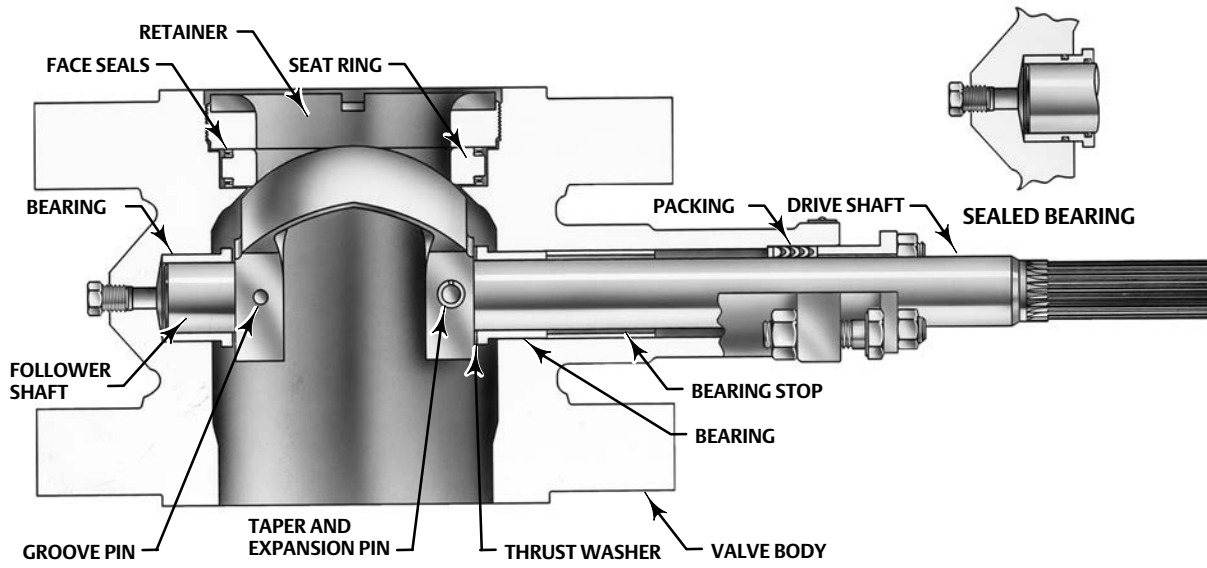

**DN 80 THROUGH 200
NPS 3 THROUGH 8**

WS793-1 / IL

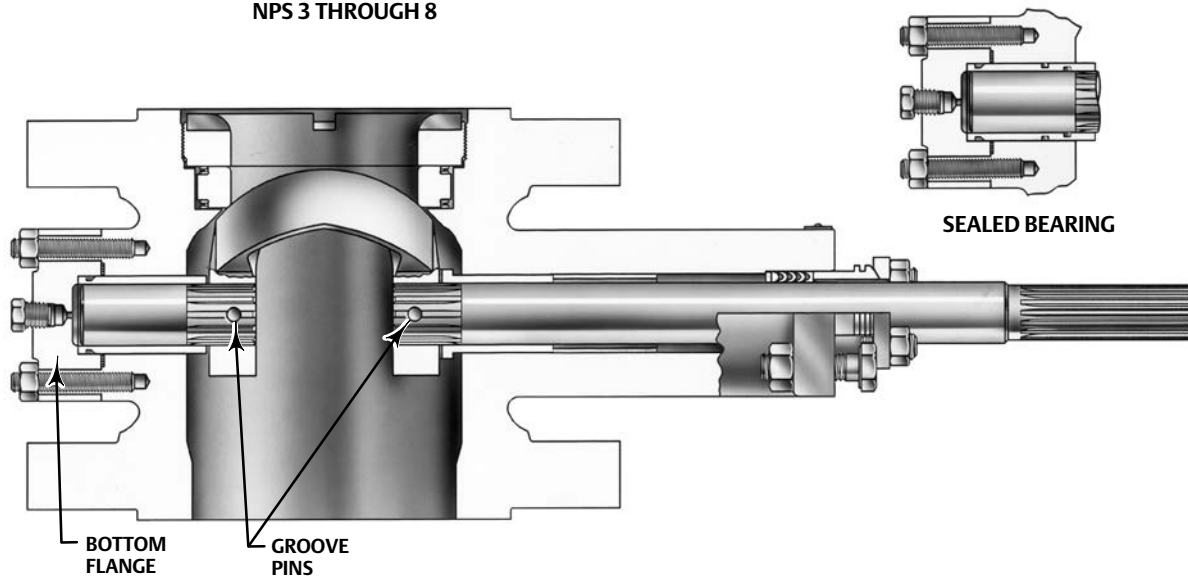

**DN 250 AND 300
NPS 10 AND 12**

WS794-1

Table 3. Valve Size, DN Ratings, and Flange Compatibility

VALVE SIZE, DN	EN					
	Flanged					
	PN 10	PN 16	PN 25	PN 40	PN 63	PN 100
80	X	X	X	X	X	X
100	X	X	X	X	X	X
150	X	X	X	X	X	X
200	X	X	X	X	X	X
250	---	---	X	X	---	---
300	---	---	X	X	---	---

X indicates availability.

Table 4. Maximum Allowable Shutoff Pressure Drops⁽²⁾

VALVE BODY MATERIAL	BEARING MATERIAL	TEMPERATURE, °C	VALVE SIZE, DN					
			80	100	150	200	250	300
			Bar					
WCC steel	S44004 (440C SST)	-29 to 149	41.4	41.4	41.4	24.1	24.1	27.6
		149 to 204	41.4	41.4	41.4	23.8	24.1	27.6
		204 to 316	41.4	41.4	41.4	23.1	24.1	27.6
WCC Steel, 1.0619 steel, CF8M (316 SST), 1.4581 SST, or CF3M ⁽³⁾ (316L SST)	R30006 (Alloy 6)	-46 ⁽¹⁾ to 204	41.4	41.4	20.7	15.2	24.1	27.6
		204 to 260	41.4	41.4	20.7	15.2	24.1	27.6
		260 to 316	41.4	41.4	20.7	15.2	24.1	27.6
	PTFE/composition-lined S31603 ⁽³⁾ (S316L SST)	-46 ⁽¹⁾ to 93	41.4	41.4	41.4	24.1	31	34.5
		93 to 149	41.4	41.4	41.4	24.1 ⁽⁴⁾ 23.1 ⁽⁵⁾	31	34.5
		149 to 204	41.4	41.4	41.4	23.8 ⁽⁴⁾ 22.1 ⁽⁵⁾	31	34.5
		204 to 232	41.4	41.4	41.4	23.4 ⁽⁴⁾ 21.7 ⁽⁵⁾	31	34.5

VALVE BODY MATERIAL	BEARING MATERIAL	TEMPERATURE, °F	VALVE SIZE, NPS					
			3	4	6	8	10	12
			Psi					
WCC steel	S44004 (440C SST)	-20 to 300	600	600	600	350	350	400
		300 to 400	600	600	600	345	350	400
		400 to 600	600	600	600	335	350	400
WCC Steel, 1.0619 steel, CF8M (316 SST), 1.4581 SST, or CF3M ⁽³⁾ (316L SST)	R30006 (Alloy 6)	-50 ⁽¹⁾ to 400	600	600	300	220	350	400
		400 to 500	600	600	300	220	350	400
		500 to 600	600	600	300	220	350	400
	PTFE/composition-lined S31603 ⁽³⁾ (S316L SST)	-50 ⁽¹⁾ to 200	600	600	600	350	450	500
		200 to 300	600	600	600	350 ⁽⁴⁾ 335 ⁽⁵⁾	450	500
		300 to 400	600	600	600	345 ⁽⁴⁾ 320 ⁽⁵⁾	450	500
400 to 450	600	600	600	340 ⁽⁴⁾ 315 ⁽⁵⁾	450	500		

1. -29°C (-20°F) for WCC steel valve body material.
2. The pressure or temperature limits in this table or in any applicable code limitation, should not be exceeded.
3. Fisher standard material offerings in Europe only.
4. S17400 (17-4PH SST) shaft only.
5. ASME SA-479 Grade S20910 stainless steel shaft only. Pressure drops appropriate for both shaft materials.

Table 5. Materials of Construction and Temperature Capabilities

PART NAME	MATERIAL	MINIMUM TO MAXIMUM TEMPERATURE		
		°C	°F	
Valve body and retainer	WCC steel bodies	CB7Cu-1 (17-4PH) retainer	-29 to 427	-20 to 800
		R30006 (Alloy 6) retainer	-29 to 427	-20 to 800
		CF8M (316 SST) retainer	-29 to 260	-20 to 500
	1.0619 steel bodies	CB7Cu-1 (17-4PH) retainer	-26 to 427	-14 to 800
		R30006 (Alloy 6) retainer	-26 to 427	-14 to 800
		CF3M (316L SST) retainer	-26 to 260	-14 to 500
	CF8M (316 SST) bodies	CF8M retainer	-198 to 427	-325 to 800
		R30006 (Alloy 6) retainer	-46 to 316	-50 to 600
		CF8M with CoCr-A (Alloy 6) bore	-198 to 427	-325 to 800
	1.4581 SST bodies	CF3M retainer	-195 to 427	-319 to 800
		R30006 (Alloy 6) retainer	-46 to 316	-50 to 600
		CF3M with CoCr-A bore	-198 to 427	-319 to 800
	CF3M ⁽¹⁾ (316L SST) bodies	CF3M retainer	-198 to 427	-325 to 800
R30006 (Alloy 6) retainer		-46 to 316	-50 to 600	
CF3M with CoCr-A bore		-198 to 427	-325 to 800	
Seat ring	CF8M	-198 to 538	-325 to 1000	
	R30006 (Alloy 6)	-198 to 538	-325 to 1000	
	CF8M with CoCr-A seat	-198 to 538	-325 to 1000	
	CF3M ⁽¹⁾	-198 to 454	-325 to 850	
	CF3M ⁽¹⁾ with CoCr-A seat	-198 to 454	-325 to 850	
Ball	Chrome plated CF3M	-198 to 316	-325 to 600	
	Chrome plated CF3M with CoCr-A V-notch	-198 to 316	-325 to 600	
Drive shaft and follower shaft	S17400 (17-4PH SST)	-62 to 427	-80 to 800	
	ASME SA479 grade S20910	-198 to 538	-325 to 1000	
Taper and expansion pins (NPS 3 through 8)	ASME SA479 grade S20910	-198 to 538	-325 to 1000	
Groove pin	S31600	-198 to 538	-325 to 1000	
Bearings	S44004 (440C SST)	-29 to 427	-20 to 800	
	R30006 (Alloy 6)	-198 to 538	-325 to 1000	
	PTFE/composition lined S31603	-46 to 232	-50 to 450	
O-rings ⁽²⁾ (for S44004 or R30006 sealed bearings)	Fluorocarbon	-18 to 204	0 to 400	
	Nitrile	-29 to 93	-20 to 200	
Bearing stop	S31600	-198 to 538	-325 to 1000	
	S31603 ⁽¹⁾	-198 to 454	-325 to 850	
Thrust washer	S17700 for S17400 drive shaft	-198 to 427	-325 to 800	
	Alloy 6B for S20910 drive shaft	-198 to 538	-325 to 1000	
Face seals	N07718	-198 to 538	-325 to 1000	
Retainer gasket	S31600	-198 to 538	-325 to 1000	
	S31603 ⁽¹⁾	-198 to 454	-325 to 850	
Packing	PTFE V-ring with one carbon-filled PTFE ring ⁽³⁾	-46 to 260	-50 to 500	
	Braided PTFE composition with one graphite filament ring ⁽⁴⁾	-73 to 260	-100 to 500	
	Graphite ribbon	-198 to 538	-325 to 1000	
Packing follower	S31600	-198 to 538	-325 to 1000	
Studs and nuts	SA-193-B7 studs and SA-194-2H nuts	-46 to 427	-50 to 800	
	SA-193-B7M studs and SA-194-2HM nuts	-29 to 427	-20 to 800	
	SA-193-B8M studs and SA-194-8M nuts	-198 to 538	-325 to 1000	
Packing box ring	S31600	-198 to 538	-325 to 1000	
	S31603 ⁽¹⁾	-198 to 454	-325 to 850	

1. Fisher standard material offerings in Europe only.
 2. For sealed bearing constructions.
 3. Carbon-filled PTFE ring used for grounding purposes.
 4. Graphite filament ring used for grounding purposes.

Installation

The CV500 control valve may be installed in any position. However, for best shutoff performance, a position with the shaft horizontal is recommended.

The control valve may be installed in forward or reverse flow direction. Forward flow (through the seat ring and past the V-notch ball) tends to open the valve; reverse flow (past the V-notch ball and through the seat ring) tends to close the valve. The forward flow direction is recommended. Refer to the Fisher CV500 Rotary Control Valve instruction manual, [D101640X012](#), to determine the proper installation orientation of the V-notch ball and actuator, and to determine the flow direction of the process fluid through the valve.

Refer to the appropriate actuator bulletin for possible assembly and installation options. For assistance in selecting the appropriate combination of actuator action and open valve position, consult your [Emerson sales office](#) or Local Business Partner.

Dimensions are shown in figure 4.

Ordering Information

Valve Information

To determine what valve ordering information is needed, refer to the specifications table. Review the information under each specification and in the referenced tables; specify your choice whenever there is a selection to be made.

Actuator and Accessory Information

Refer to the specific actuator and accessory bulletins for required ordering information.

Figure 3. Eccentric V-Notch Ball Rotation

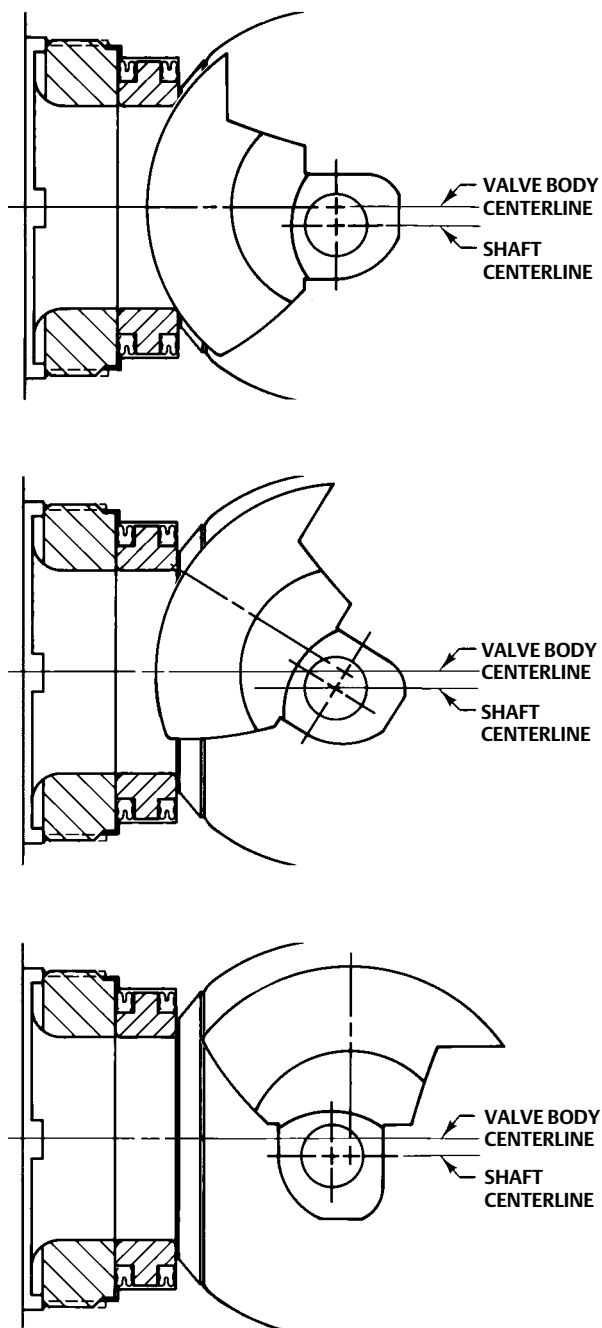

82333

Table 6. Fisher CV500 Valve Body Dimensions

VALVE SIZE	DIMENSIONS									
	A		B		D	K	S (Shaft Dia) ⁽¹⁾	T	U	W
	RF	RTJ	RF	RTJ						
DN	mm									
80	165	165	83	83	213	200	25.4 25.4 x 19.1	152	32	14
100	194	194	97	97	208	216	31.8	235	46	18
150	229	229	114	114	208	270	38.1 38.1 x 31.8	235	46	5/8-inch 11 UNC
200	243	243	121	121	208	318	38.1	235	46	5/8-inch 11 UNC
250	297	312	148	156	356	353	44.5	273	51	3/4-inch 10 UNC
300	338	354	169	177	356	408	53.8 53.8 x 50.8	273	51	3/4-inch 10 UNC
NPS	Inches									
3	6.50	6.50	3.25	3.25	8.44	7.88	1.00 1.00 x 0.75	6.00	1.25	0.56
4	7.62	7.62	3.81	3.81	8.19	8.50	1.25	9.25	1.81	0.69
6	9.00	9.00	4.50	4.50	8.19	10.62	1.50 1.50 x 1.25	9.25	1.81	5/8-inch 11 UNC
8	9.56	9.56	4.78	4.78	8.19	12.50	1.50	9.25	1.81	5/8-inch 11 UNC
10	11.68	12.30	5.84	6.15	14.00	13.91	1.75	10.75	2.00	3/4-inch 10 UNC
12	13.31	13.93	6.66	6.97	14.00	16.07	2.12 2.12 x 2.00	10.75	2.00	3/4-inch 10 UNC

1. Shaft diameter versus spline diameter.

Figure 4. Fisher CV500 Valve Body Dimensions (also see table 6)

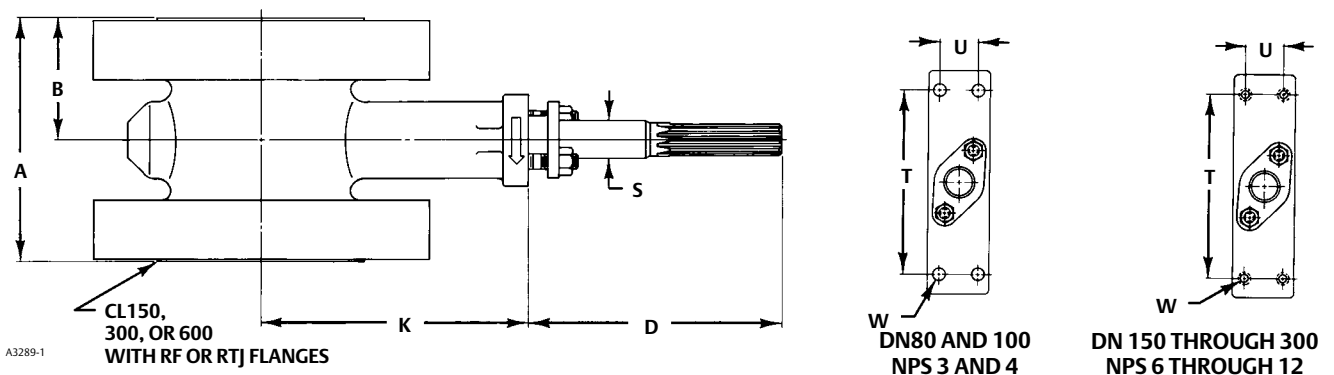

Note:
For dimensions of valves with DN (or other) end connections, contact your [Emerson sales office](#) or Local Business Partner.

Neither Emerson, Emerson Process Management, nor any of their affiliated entities assumes responsibility for the selection, use or maintenance of any product. Responsibility for proper selection, use, and maintenance of any product remains solely with the purchaser and end user.

Fisher, Vee-Ball, and ENVIRO-SEAL are marks owned by one of the companies in the Emerson Process Management business unit of Emerson Electric Co. Emerson Process Management, Emerson, and the Emerson logo are trademarks and service marks of Emerson Electric Co. All other marks are the property of their respective owners.

The contents of this publication are presented for informational purposes only, and while every effort has been made to ensure their accuracy, they are not to be construed as warranties or guarantees, express or implied, regarding the products or services described herein or their use or applicability. All sales are governed by our terms and conditions, which are available upon request. We reserve the right to modify or improve the designs or specifications of such products at any time without notice.

Emerson Process Management
Marshalltown, Iowa 50158 USA
Sorocaba, 18087 Brazil
Cernay, 68700 France
Dubai, United Arab Emirates
Singapore 128461 Singapore

www.Fisher.com

