

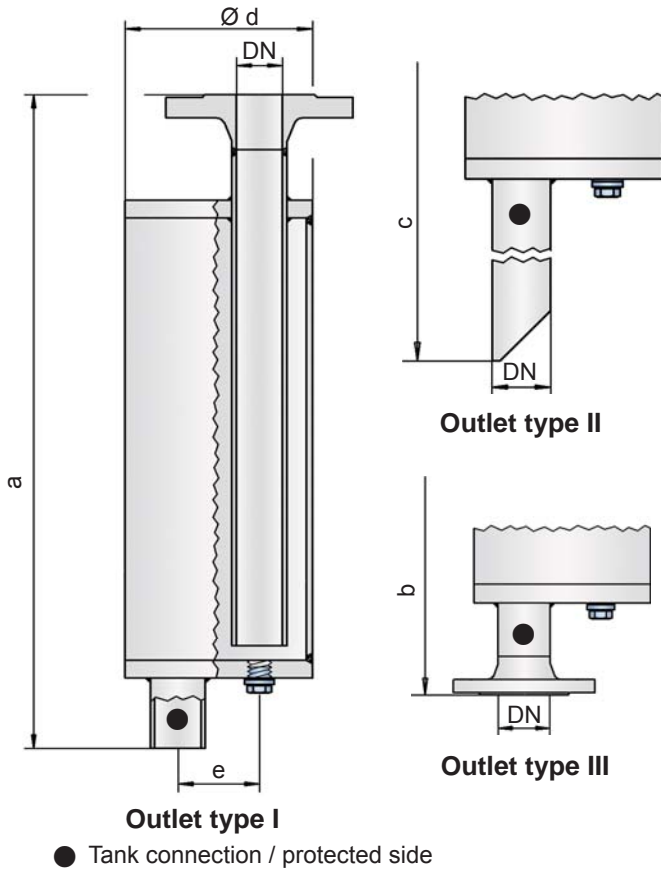

Liquid Detonation Flame Arrester

for filling lines - internal installation

PROTEGO® LDA



The device is installed inside the tank at the end of the line and prevents the combustion from being transferred into the tank if the explosive atmosphere ignites. The liquid detonation arresters function according to the siphon principle in which the liquid product serves as a liquid barrier to flame propagation.

When a highly accelerated pipe deflagration or detonation occurs, the combustion pressure and flame propagation speed is first substantially reduced by the design and converted into a low-energy deflagration that is then stopped by the remaining immersion liquid.

The application range for the device is a product vapour/air mixture temperature up to + 60°C / 140°F and an absolute pressure up to 1.1 bar / 15.9 psi. This covers all of the possible operating conditions of empty lines for flammable liquids. The liquid detonation arrester is pressure-resistant up to 10 bar / 145 psi. The device protects against nearly all flammable liquids, and is approved for explosion groups IIA to IIB3 (NEC group D to C MESH ≥ 0.65 mm). Special designs with a cleaning cover for highly viscous liquids can be provided.

Type-approved in accordance with the current ATEX Directive and EN ISO 16852 as well as other international standards.

Special Features and Advantages

- simple construction that helps prevent soiling
- low pressure loss
- provides protection from deflagrations and stable detonations
- useful for nearly all flammable liquids
- meets TRbF* requirements
- deliverable with different outlets

*TRbF = technical regulations for flammable liquids

Function and Description

The PROTEGO® LDA series of liquid detonation arresters was developed for storage tank filling lines that are not continuously filled with product and sometimes contain a combustible mixture.

Table 1: Dimensions

Dimensions in mm / inches

To select the nominal size (DN), please use the flow capacity chart on the following pages

DN	25 1"	32 1 ¼"	40 1 ½"	50 2"	65 2 ½"	80 3"	100 4"	125 5"	150 6"	200 8"	250 10"
a	500 / 19.69	580 / 22.83	700 / 27.56	700 / 27.56	825 / 32.48	925 / 36.42	1050 / 41.34	1150 / 45.28	1350 / 53.15	1650 / 64.96	2000 / 78.74
b	538 / 21.18	620 / 24.41	745 / 29.33	745 / 29.33	870 / 34.25	975 / 38.39	1102 / 43.39	1205 / 47.44	1405 / 55.31	1712 / 67.40	2068 / 81.42
c	725 / 28.54	805 / 31.69	925 / 36.42	925 / 36.42	1050 / 41.34	1145 / 45.08	1270 / 50.00	1380 / 54.33	1580 / 62.20	1880 / 74.02	2300 / 90.55
d	115 / 4.53	140 / 5.51	168 / 6.61	168 / 6.61	220 / 8.66	245 / 9.65	325 / 12.80	356 / 14.02	500 / 19.69	600 / 23.62	700 / 27.56
e	50 / 1.97	58 / 2.28	65 / 2.56	65 / 2.56	95 / 3.74	105 / 4.13	135 / 5.31	155 / 6.10	200 / 7.87	250 / 9.84	300 / 11.81

Table 2: Selection of the explosion group

MESG	Expl. Gr. (IEC/CEN)	Gas Group (NEC)	
> 0,90 mm	IIA	D	Special approvals upon request
≥ 0,65 mm	IIB3	C	

Table 3: Specification of max. operating temperature

≤ 60°C / 140°F	Tmaximum allowable operating temperature in °C	higher operating temperatures upon request
-	Designation	

Table 4: Material selection for housing

Design	A	B	
Housing	Steel	Stainless Steel	Special materials upon request
Gasket	PTFE	PTFE	

Table 5: Flange connection type

EN 1092-1; Form B1	other types upon request
ASME B16.5; 150 lbs RFSF	

Table 6: Outlet type

Straight pipe	I	other types upon request
Beveled pipe	II	
EN 1092-1; Form B1	III	
ASME B16.5; 150 lbs RFSF	III	

Flow Capacity Chart

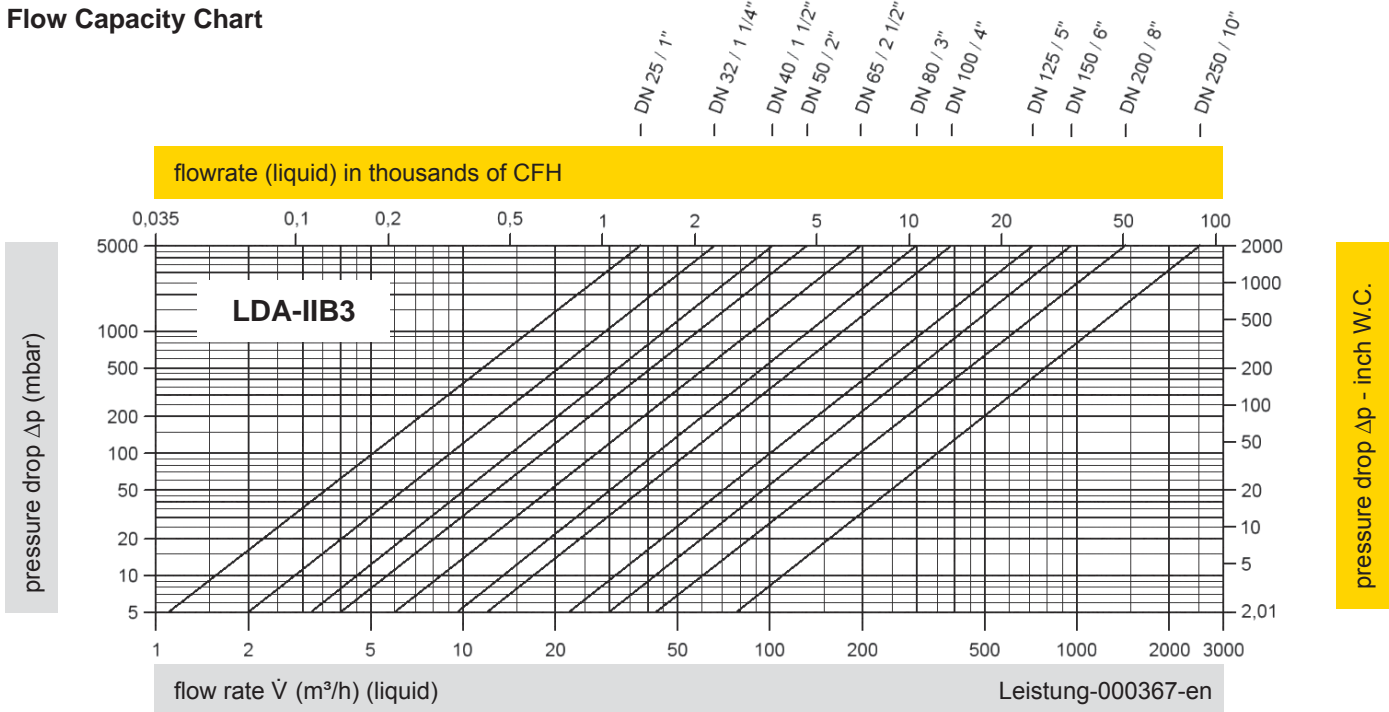

Conversion: $\dot{V}_{liquid} = \dot{V}_{water} * \sqrt{\frac{\rho_{water}}{\rho_{liquid}}}$

The volume flow \dot{V} in m³/h was determined with water according to DIN EN 60534 at a temperature $T_n = 15^\circ\text{C}$ and an atmospheric pressure $p_n = 1,013 \text{ bar}$, kinematic viscosity $\nu = 10^{-6} \text{ m}^2/\text{s}$. To avoid electrostatic charge of flammable liquids the maximum flow is limited (refer to BG-Regulation 132, CENELEC-Report CLC/TR 50404).

