

General Description

The HOV13(B) is a push-type, bronze bodied safety valve, electrohydraulically operated to provide reliable ON-OFF control of fuel oil. The spring-loaded stem-guided PTFE seat opens within nine seconds of power application and firmly closes within one second of power interruption.

The valve is agency approved for fuel oil safety shutoff service on the N.C. port. The N.O. port typically provides return to the oil preheater during the off cycle.

The electrohydraulic actuator can be purchased separately, and consists of a pump applying pressure to a piston pushing the valve stem. Its power unit is immersed in oil and sealed. The HOV13(B) assembly, which consists of an actuator and the valve body mounted together by users, requires no adjustment or service. Stroke is controlled by a travel limit switch and electromagnetic relief valve. The unit rotates 360° for ease of installation. Two-wire connection via 1/2 inch threaded conduit terminal box is standard.

The HOV13(B) comes standard with valve seal overtravel and electrical interlock proof of closure switch. An optional auxiliary switch is also available.

Fluid

No. 2 Fuel Oil at 60 SSU No. 5 Fuel Oil at 5000 SSU
No. 4 Fuel Oil at 300 SSU No. 6 Fuel Oil at 5000 SSU (Heated)

Specifications

Opening Time: 9 seconds max.

Closing Time: 1 second max.

Note: Opening time is double between -30°F and -40°F ambient. Opening time increases 20% when operating at 50Hz.

Ambient Temperature: -40°F to 150°F (-40°C to 66°C)

Fluid Temperature: 267° max. (131°C)

Body/Trim: Bronze, 300# screw

Seal Material: PTFE

Port Size: 13/32"

Enclosure

Standard: General Purpose Type 1

Optional: Watertight Type 4

(Also meets General Purpose Type 1 and Raintight Type 3)

Electrical

Standard voltages: 120V/60Hz (or 110V/50Hz)

Non-standard voltages: 24V/60Hz; 240V/60Hz (or 220V/50Hz)

Proof of Closure Switch (POC): (standard)

A factory set, non-field adjustable SPDT switch. 1800VA max. connected load (e.g. one 15A max. load @ 24V or 120V; one 7.5A max. load at 240V).

Auxiliary Switch: (optional)

One integral SPDT switch; field adjustable to actuate at any position of stroke. 1800 VA max. connected load

(e.g. one 15A max. load @ 24V or 120V; one 7.5A max. load at 240V).

To order, change last digit of part number from "0" to "1".

(e.g. assembly, HOV13B162T171; e.g. actuator, HO1B252A171)



Electrical Characteristics

Voltage/Hz*	Amperes		
	Inrush	Opening	Holding
24V/60	28	8.2	0.49
120V/60, 110/50	5.6	2.1	0.09
240V/60, 220/50	2.8	1.1	0.04

*Current increases by 20% for 50 Hz operation.

Installation

HO(B) actuator mounts in any position directly to a V13 valve body with 3 set screws.

Approvals

UL listed to standard 429 "Electrically Operated Valves", Guide YIOZ, File MP932

FM Approved to Class 7400 "Liquid and Gas Safety Shutoff Valves"

CSA Certified to "Electrically Operated Valves", CSA Std C22.2 No. 139, File 109157

Ordering Information

Important: HOV13(B) can be purchased as an assembly, which includes the actuator & valve packaged in one box, or separately as HO(B) actuator & V13 valve body. (e.g. assembly, HOV13B162T170) (e.g. actuator, HO1B252A170) (e.g. valve body, V13FS2D03T166)

Specifications (English units)

Pipe Size (in)	Cv Flow Factor	Operating Pressure Differential (psi)		Max. Fluid Temp. °F	Catalog Number 120V/60Hz (or 110V/50Hz)			Const. Ref.	Agency			Max. Opening Time (Sec.)
		Min.	Max.		HO(B) Actuator ①	V13 Valve Body	HOV13(B) Assembly ②		UL	FM	CSA	
COMBUSTION (Fuel Oil) - General Purpose												
With Proof of Closure Switch												
1/2	2.5	0	300	267	HO1B252A170	V13FS2D03T166	HOV13B162T170	1	○	○	○	9
3/4	3	0	300	267		V13FS2E04T166	HOV13B167T170		○	○	○	9
With Proof of Closure & Auxiliary Switch												
1/2	2.5	0	300	267	HO1B252A171	V13FS2D03T166	HOV13B162T171	1	○	○	○	9
3/4	3	0	300	267		V13FS2E04T166	HOV13B167T171		○	○	○	9
COMBUSTION (Fuel Oil) - Watertight												
With Proof of Closure Switch												
1/2	2.5	0	300	267	HO2B252A170	V13FS2D03T166	HOV23B162T170	1	○	○	○	9
3/4	3	0	300	267		V13FS2E04T166	HOV23B167T170		○	○	○	9
With Proof of Closure & Auxiliary Switch												
1/2	2.5	0	300	267	HO2B252A171	V13FS2D03T166	HOV23B162T171	1	○	○	○	9
3/4	3	0	300	267		V13FS2E04T166	HOV23B167T171		○	○	○	9

① For 24V/60Hz, change 7th digit to "1" (EX: HO1B251A170); For 240V/60Hz (or 220V/50Hz), change 7th digit to "4" (EX: HO1B254A170)
 ② For 24V/60Hz, change 9th digit, for 1/2" to "1", for 3/4" to "6" (EX: HOV13B161T170, HOV13B166T170)
 For 240V/60Hz (or 220V/50Hz), change 9th digit, for 1/2" to "3", for 3/4" to "8" (EX: HOV13B163T170, HOV13B168T170)

Specifications (Metric units)

Pipe Size (in)	Kv Flow (m³/hr)	Operating Pressure Differential (bar)		Max. Fluid Temp. °C	Catalog Number 120V/60Hz (or 110V/50Hz)			Const. Ref.	Agency			Max. Opening Time (Sec.)
		Min.	Max.		HO(B) Actuator ①	V13 Valve Body	HOV13(B) Assembly ②		UL	FM	CSA	
COMBUSTION (Fuel Oil) - General Purpose												
With Proof of Closure Switch												
1/2	2.1	0	20.7	131	HO1B252A170	V13FS2D03T166	HOV13B162T170	1	○	○	○	9
3/4	2.6	0	20.7	131		V13FS2E04T166	HOV13B167T170		○	○	○	9
With Proof of Closure & Auxiliary Switch												
1/2	2.1	0	20.7	131	HO1B252A171	V13FS2D03T166	HOV13B162T171	1	○	○	○	9
3/4	2.6	0	20.7	131		V13FS2E04T166	HOV13B167T171		○	○	○	9
COMBUSTION (Fuel Oil) - Watertight												
With Proof of Closure Switch												
1/2	2.1	0	20.7	131	HO2B252A170	V13FS2D03T166	HOV23B162T170	1	○	○	○	9
3/4	2.6	0	20.7	131		V13FS2E04T166	HOV23B167T170		○	○	○	9
With Proof of Closure & Auxiliary Switch												
1/2	2.1	0	20.7	131	HO2B252A171	V13FS2D03T166	HOV23B162T171	1	○	○	○	9
3/4	2.6	0	20.7	131		V13FS2E04T166	HOV23B167T171		○	○	○	9

① For 24V/60Hz, change 7th digit to "1" (EX: HO1B251A170); For 240V/60Hz (or 220V/50Hz), change 7th digit to "4" (EX: HO1B254A170)
 ② For 24V/60Hz, change 9th digit, for 1/2" to "1", for 3/4" to "6" (EX: HOV13B161T170, HOV13B166T170)
 For 240V/60Hz (or 220V/50Hz), change 9th digit, for 1/2" to "3", for 3/4" to "8" (EX: HOV13B163T170, HOV13B168T170)

COMBUSTION

Dimensions inches (mm)

3-Way Valve Body Dimensions Table									
Const. Ref.		A	B	C	D	E	F	G	H
1	in	6.57	3.75	1.87	2.06	2.83	3.15	1.57	2.60
	mm	166.8	95.3	47.6	52.4	72	80	40	66

Approx. Shipping Weight (lbs)		
Actuator	Valve Body	HOV13B Assembly
10.4	6.4	16.8

Const. Ref. 1

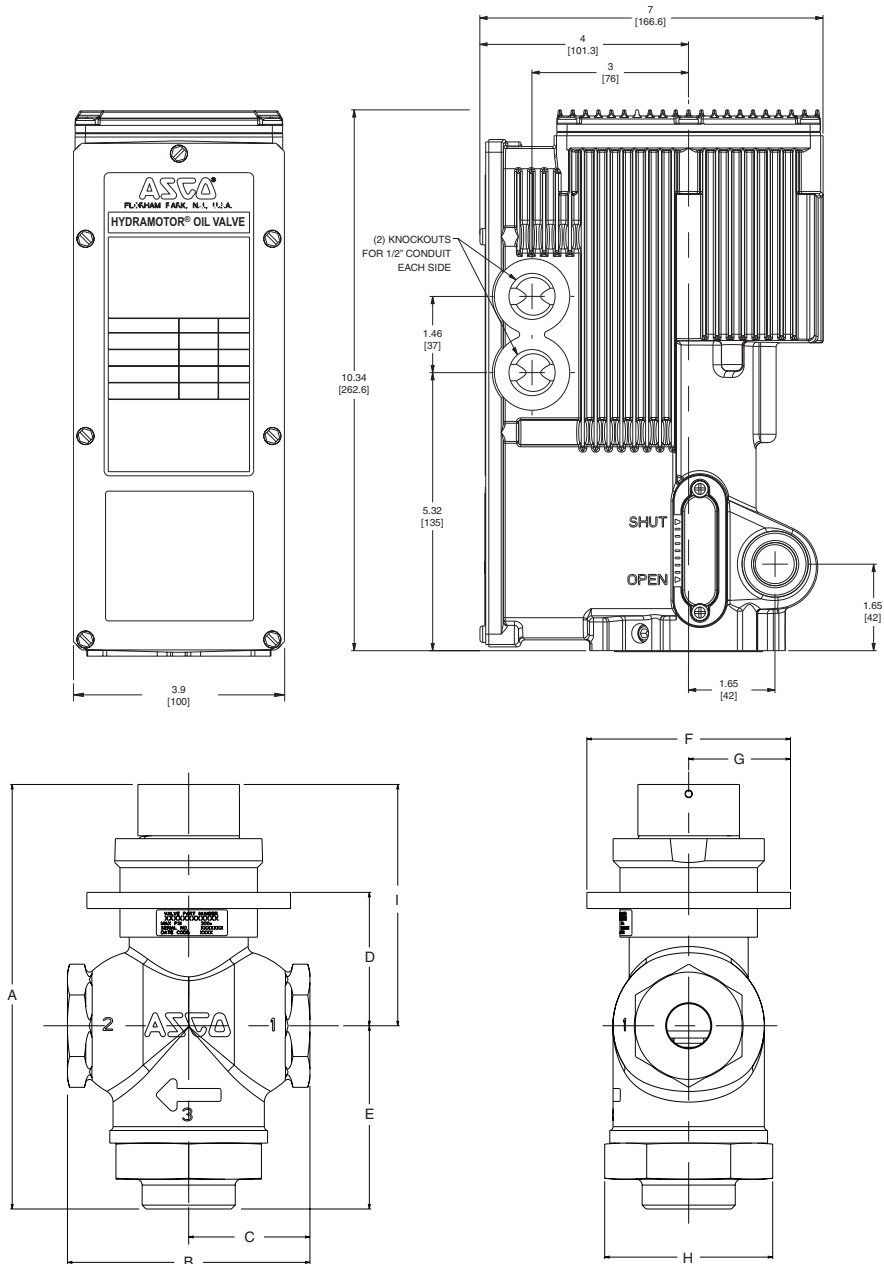

Dimensions inches (mm)

3-Way Assembly Dimensions Table						
Const. Ref.		A	B	C	D	E
1	in	3.75	2.83	2.06	15.24	2.60
	mm	95.3	72	52.4	387	66

Actuator Rebuild Kit	Part Number
Auxiliary Switch Kit	296804
Proof of Closure Switch Kit	296806
Limit Switch Kit	296807

Const. Ref. 1

