

Rosemount™ 2130 Level Switch

Functional Safety Manual



Contents

Section 1: Introduction

1.1 Scope and purpose of the safety manual	1
1.2 Terms and definitions	1
1.3 Skill level requirement	3
1.4 Documentation and standards	3

Section 2: Product Description

2.1 Operation principle	5
2.2 Level switch purpose	5
2.3 Ordering information	6

Section 3: Designing a Safety Function Using the Rosemount 2130

3.1 Safety function	7
3.2 Environmental limits	7
3.3 Application limits	7
3.4 SIL capability	8
3.4.1 Systematic capability	8
3.4.2 Random capability	8
3.4.3 Failure rates in FIT	9
3.5 Safety certified identification	9
3.6 Design verification	10
3.7 Proof-testing	10
3.7.1 Overview	10
3.7.2 Comprehensive proof-test	11
3.7.3 Partial proof-test	12
3.7.4 Proof-test interval	12
3.7.5 Tools required	12
3.7.6 Data required	12
3.8 Connection of the level switch to the SIS logic solver	13
3.9 General requirements	13

Section 4: Installation and Commissioning

4.1 Safety messages	15
4.2 Installation	15
4.3 Physical location and placement	16

4.4 Electrical connections 16
4.5 Configuration 17
 4.5.1 Self-check setting 17
 4.5.2 Output mode setting 17

Section 5: Operation and Maintenance

5.1 Proof-test requirement 19
5.2 Repair and replacement 19
5.3 Notification of failures 19

Appendix A: Specifications

A.1 General 21
A.2 Useful life 21
A.3 Useful lifetime 22

Appendix B: Proposed Comprehensive Proof-test Procedure

B.1 Suggested proof-test 23
B.2 Impact on SIF and process 24
B.3 Duration of comprehensive proof-test 24
B.4 Personal safety concerns 24

Appendix C: Proposed Partial Proof-test Procedure

C.1 Suggested proof-test 25
C.2 Impact on SIF and process 25
C.3 Duration of partial proof-test 25
C.4 Personal safety concerns 25

Appendix D: PFDavg Calculation

D.1 Average probability of failure on demand (PFDavg) - 2-Wire/Direct-Load (Dry=On) 27
D.2 Average probability of failure on demand (PFDavg) - 2-Wire/Direct-Load (Wet=On) 30
D.3 Average probability of failure on demand (PFDavg) - 8 and 16 mA (Dry=On) 32
D.4 Average probability of failure on demand (PFDavg) - 8 and 16 mA (Wet=On) 34
D.5 Average probability of failure on demand (PFDavg) - NAMUR (Dry=On) 36
D.6 Average probability of failure on demand (PFDavg) - NAMUR (Wet=On) 38
D.7 Average probability of failure on demand (PFDavg) - PNP/PLC (Dry=On) 40
D.8 Average probability of failure on demand (PFDavg) - PNP/PLC (Wet=On) 42
D.9 Average probability of failure on demand (PFDavg) - Relay (Dry=On) 44
D.10 Average probability of failure on demand (PFDavg) - Relay (Wet=On) 46

Appendix E: PFH Calculation

E.1 Probability of dangerous failure per hour (PFH)..... 49

Appendix F: Diagnostic Intervals

F.1 Diagnostic checks and intervals 51

Section 1 Introduction

1.1 Scope and purpose of the safety manual

This safety manual contains the information to design, install, verify and maintain a Safety Instrumented Function (SIF) utilizing the Rosemount™ 2130 Level Switch (“level switch”).

The manual provides the necessary requirements to enable the integration of the level switch when showing compliance with the IEC 61508 or IEC 61511 functional safety standards. It indicates all assumptions that have been made on the usage of the level switch. If these assumptions cannot be met by the application, the SIL capability of the level switch may be adversely affected.

Note

For product support, use the contact details on the back page.

1.2 Terms and definitions

Table 1-1. Terms and Definitions

Term	Definition
λ .DD	Dangerous Detected
λ .DU	Dangerous Detected
λ .SD	Safe Detected
λ .SU	Safe Undetected
BPCS	Basic Process Control System
CPT	Comprehensive Proof Test
Diagnostic Coverage	[DC] Percentage of detectable faults to undetectable faults
Diagnostic Test Interval	Time during which all internal diagnostics are carried out at least once.
Fail dangerous	Failure that does not respond to an input from the process (i.e. not switching to the fail-safe state).
Fail Dangerous Detected	Failure that is dangerous but is detected.
Fail Dangerous Undetected	Failure that is dangerous and that is not detected.
Fail No Effect	Failure of a component that is part of the safety function but that has no effect on the safety function.
Fail Safe	Failure that causes the switch to go to the defined fail-safe state without an input from the process.
Fail-safe state	State where the switch output is in the state corresponding to an alarm condition. In this condition, the switch contacts will normally be open.
FIT	Failure In Time per billion hours
FMEDA	Failure Modes, Effects and Diagnostic Analysis

Table 1-1. Terms and Definitions

Functional Safety	Part of the overall safety relating to the process and the BPCS which depends on the correct functioning of the SIS and other protection layers.
HFT	Hardware Fault Tolerance as defined by 61508-2 7.4.4.1.1
High demand mode	The safety function is only performed on demand, in order to transfer the EUC (Equipment Under Control) into a specified safe state, and where the frequency of demands is greater than one per year (IEC 61508-4).
Low demand mode	The safety function is only performed on demand, in order to transfer the EUC into a specified safe state, and where the frequency of demands is no greater than one per year (IEC 61508-4).
Level switch response time	The time from a step change in the process until a level switch output reaches 90% of its final steady state value (step response time as per IEC 61298-2).
PFD_{AVG}	Average Probability of Failure on Demand
PFH	Probability of dangerous failure per hour.
PPT	Partial Proof Test
Random Integrity	The SIL limit imposed by the architectural constraints that must be met for each element.
Safety Demand Interval	The expected time between safety demands.
SFF	Safe Failure Fraction
SIF	Safety Instrumented Function
SIL	Safety Integrity Level - a discrete level (one out of four) for specifying the safety integrity requirements of the safety instrumented functions to be allocated to the safety instrumented systems. SIL 4 has the highest level of safety integrity, and SIL 1 has the lowest level.
SIS	Safety Instrumented System (SIS) - an instrumented system used to implement one or more safety instrumented functions. An SIS is composed of any combination of sensors, logic solvers, and final elements.
Systematic Capability	A measure (expressed on a scale of SC 1 to SC 4) of the confidence that the systematic safety integrity of an element meets the requirements of the specified SIL, in respect of the specified element safety function, when the element is applied in accordance with the instructions specified in the compliant item safety manual for the element as per 61508-4.
Type B device	Complex device using controllers or programmable logic, as defined by the standard IEC 61508.

1.3 Skill level requirement

System design, installation and commissioning, and repair and maintenance shall be carried out by suitably qualified personnel.

1.4 Documentation and standards

This section lists the documentation and standards referred to by this safety manual.

Table 1-2. Associated Documentation

Documents	Purpose of documents
00813-0100-4130	Rosemount 2130 Product Data Sheet
00809-0100-4130	Rosemount 2130 Reference Manual
IEC 61508: 2010	Functional Safety of Electrical/Electronic/Programmable Electronic Safety-Related Systems
MOB 08-08-57 R005	FMEDA Report Version V2, Revision R1 and later, for the Rosemount 2130 Level Switch

Table 1-3. Associated Standards

Standards	Purpose of standards
HRD 5:1994	Handbook of Reliability Data for Components used in Telecommunication systems
IEC 60664-1	Insulation coordination for equipment with low voltage systems
IEC 61511 (ANSI/ISA 84.00.01-2004)	Functional safety - Safety instrumented systems for the process industry sector
IEC 61984	Connectors - Safety requirements and test

Section 2 Product Description

2.1 Operation principle

The Rosemount™ 2130 Level Switch (“level switch”) consists of a tuned fork with a driver and receiver element, and integral interface electronics. The level switch is based on the principle that the resonant frequency of a tuned fork changes when it is immersed in a liquid. The frequency change is detected and used to switch an electrical output.

A range of output options are available to suit different applications.

Note

For all product information and documentation downloads, visit Emerson.com/Rosemount.

2.2 Level switch purpose

The level switch indicates, by means of an electronic output, whether the level of a process liquid is above, or below, a certain point (the switching point).

Figure 2-1. Example Application

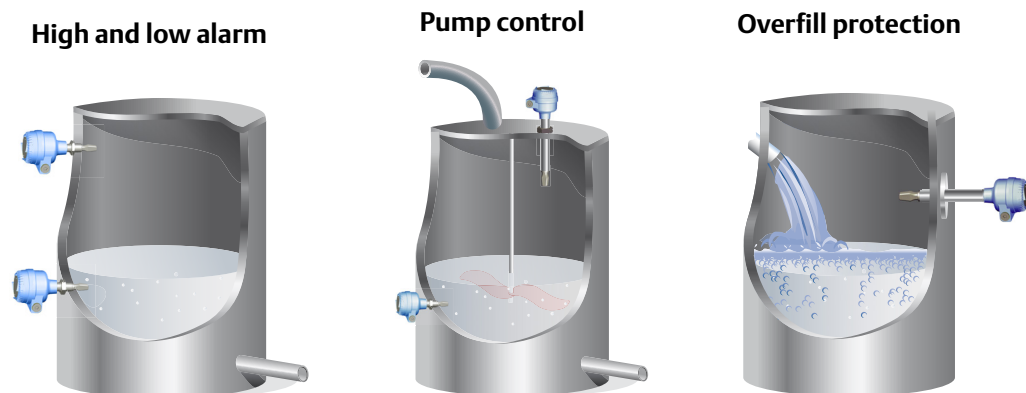

2.3 Ordering information

Typical Model Number: 2130 L A 2 E S 9 N N B A 0000 1 N A Q T

The third option code after “2130” indicates the output type:

- D = Relay
- D (with option R2264) = Fault Relay
- L = Direct Load Switching (Mains two-wire)
- M = 8 and 16 mA
- N = NAMUR
- P = PNP/PLC Low Voltage (three-wire)

Output types D, L, M, N and P have achieved a SIL rating. Each of these output types has different Safety Instrumented System (SIS) parameters (see [Table 3-1 on page 9](#)).

The other option codes in the model number refer to materials, fittings, and other mechanical options which do not affect SIS parameters.

Models with the QS option code are supplied with a manufacturer's prior-use certificate of FMEDA data.

Models with the QT option, if available, are supplied with a third-party certificate of SIL capability.

Section 3 Designing a Safety Function Using Rosemount 2130

3.1 Safety function

For safety instrumented systems usage, the electrical output is used as the primary safety variable. It is important that the level switch is user-configured for the correct application.

The measurement signal used by the logic solver must be the discrete levels set at the instrument output used to indicate the sensor condition. A change in liquid level through the switch point of the level switch results in the user configured state being set at the output by the instrument.

3.2 Environmental limits

The designer of the SIF (Safety Instrumented Function) must check that the level switch is rated for use within the expected environmental limits. See the Rosemount™ 2130 Level Switch [Product Data Sheet](#) for environmental limits.

Note

For all product information and documentation downloads, see the on-line Rosemount 2130 web page at Emerson.com/Rosemount.

3.3 Application limits

⚠ WARNING

Failure to comply with the following requirements will result in the invalidation of the products safety certification.

- Check for risk of media build-up on the forks. Avoid situations where drying and coating products may create excessive build-up (see [Figure 3-1 on page 8](#)) or implement preventative maintenance programs to ensure the media buildup is insufficient to impair performance.
- Ensure there is no risk of 'bridging' the forks. Examples of products that create 'bridging' of forks are dense paper slurries and bitumen.

It is very important that the SIF designer checks for material compatibility by considering process liquids and on-site chemical contaminants. If the level switch is used outside the application limits or with incompatible materials, the reliability data and predicted SIL capability becomes invalid.

The construction materials of a level switch are specified in the product data sheet and the product reference manual. Use the model code on the product label, and the ordering information table and specification in these product documents, to find out the construction materials.

Figure 3-1. Product Build-up

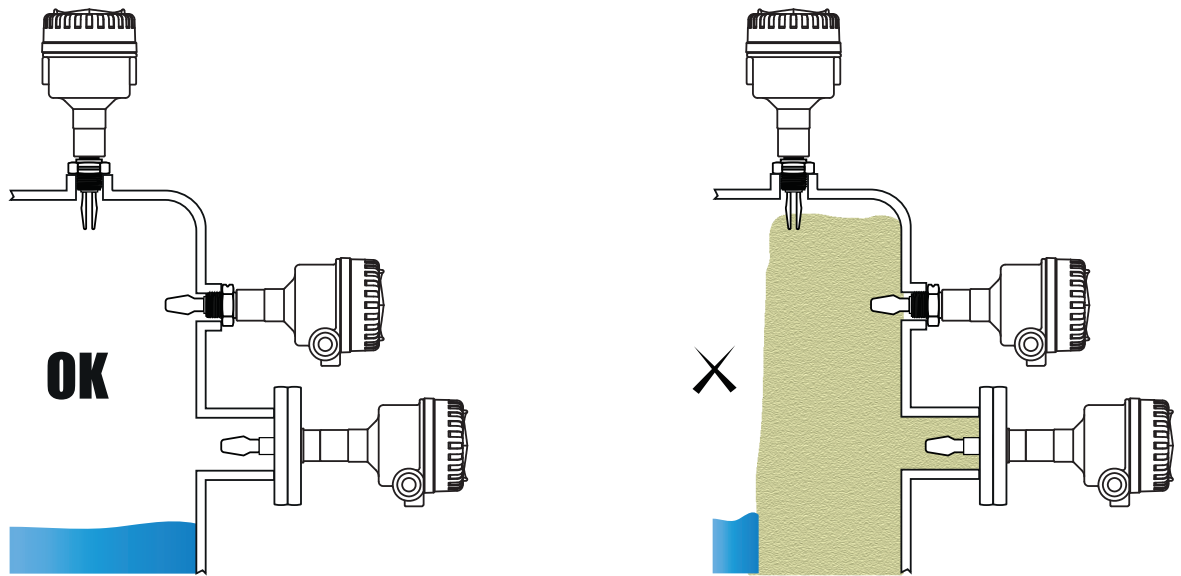

3.4 SIL capability

The following sub-sections describe the third-party assessed SIS parameters of the Rosemount 2130 Level Switch (“level switch”). A safety Instrumented Function (SIF) designed with this product must not be used at a SIL higher than stated.

3.4.1 Systematic capability

Output types D, M and N have met the manufacturer design process requirements of Safety Integrity Level (SIL) 3 (IEC61508:2010).

Output types L and P have met the manufacturer design process requirements of Safety Integrity Level (SIL) 2 (IEC61508:2000).

These are intended to achieve sufficient Integrity against systematic errors of design by the manufacturer.

3.4.2 Random capability

The level switch is classified as a type B device according to IEC61508.

Random Integrity for Type B device:

- Low and high demand: Type B element
- Output types M and N: SIL 2 @HFT=0, SIL 3 @HFT=1 (IEC61508:2010)
- Output type D: SIL 1 @HFT=0, SIL 2 @HFT=1 (IEC61508:2010)
- Output types L and P: SIL 2 @HFT=0 (IEC61508:2000)

3.4.3 Failure rates in FIT

Table 3-1 summarizes the level switch failure rates. For detailed failure rate information, including PFD_{AVG} and MTTR data, see the FMEDA report for the Rosemount 2130.

Table 3-1. Assessed Values

Output type and model option code		Mode	Failure rate (FIT)				SFF(%)	DC(%)
			λ_{SD}	λ_{SU}	λ_{DD}	λ_{DU}		
2-Wire/Direct-Load	L	Dry=On	0	342	156	44	91.9	28.7
2-Wire/Direct-Load	L	Wet=On	0	247	278	55	90.6	47.9
8 and 16 mA	M	Dry=On	0	155	171	25	93.0	48.7
8 and 16 mA	M	Wet=On	0	41	276	35	90.1	78.4
NAMUR	N	Dry=On	0	134	150	18	94.0	49.6
NAMUR	N	Wet=On	0	16	256	29	90.4	85
PNP/PLC	P	Dry=On	0	400	163	45	92.7	26.8
PNP/PLC	P	Wet=On	0	308	284	54	91.7	43.9
Relay	D	Dry=On	0	146	148	94	75.8	38.1
Relay	D	Wet=On	0	31	253	104	73.2	65.2

Note

The FMEDA report is available from the Rosemount 2130 Level Switch - Vibrating Fork web site page at Emerson.com/Rosemount. In the Documents section, there are SIL documents including the FMEDA report and this safety manual.

3.5 Safety certified identification

All Rosemount 2130 Level Switches must be identified as safety certified before installing into SIS systems. Verify that:

1. The model code is suffixed with the QT option code.
2. A yellow tag is affixed to the outside of the levelswitch.

3.6 Design verification

The Failure Modes, Effects and Diagnostics Analysis (FMEDA) report for the Rosemount 2130 Level Switch details all failure rates and failure modes as well as expected lifetime.

The achieved Safety Integrity Level (SIL) of an entire Safety Instrumented Function (SIF) design must be verified by the designer using a PFDAVG calculation considering the architecture, proof-test interval, proof-test effectiveness, any automatic diagnostics, average repair time, and the specific failures rates of all equipment included in the SIF.

Each subsystem must be checked to assure compliance with minimum Hardware Fault Tolerance (HFT) requirements. When using the level switch in a redundant configuration, a common cause factor of at least five percent should be included in the safety integrity calculations.

The failure rate data listed in the FMEDA report is only valid for the useful lifetime of the level switch. The failure rates increase after this useful lifetime period has expired. Reliability calculations based on the data listed in the FMEDA report for mission times beyond the lifetime may yield results that are too optimistic, i.e. the calculated SIL will not be achieved.

3.7 Proof-testing

3.7.1 Overview

The Rosemount 2130 Level Switch (“level switch”) must be tested at regular intervals to detect any failures not detected by automatic on-line diagnostics i.e. dangerous failures, diagnostic failures, parametric failures such that the unit can be repaired and returned to an equivalent as new state.

It is the user's responsibility to choose the type of testing applied to the unit within their safety system.

If an error is found in the safety functionality, the switch shall be put out of operation and the process shall be kept in a safe state by other measures until a repaired or replacement unit can be installed and commissioned.

The following proof-tests are suggested:

- Comprehensive (“bucket”) test
- Partial proof-test

Table 3-2 on page 11 can be used as guidance for selecting the appropriate proof-test.

Table 3-2. Suggested Proof-tests

Output Type and Model Option Code		Proof-test type	Proof-test type	Proof-test coverage (% of DU)	Remaining dangerous, undetected failures	Test coverage		
						Output circuitry	Measurement electronics	Sensor
2-Wire/Direct-Load	L	Dry=On	Comprehensive	78	11	Yes	Yes	Yes
2-Wire/Direct-Load	L	Wet=On		81	11			
8 and 16 mA	M	Dry=On		93	2			
8 and 16 mA	M	Wet=On		95	2			
NAMUR	N	Dry=On		93	2			
NAMUR	N	Wet=On		95	2			
PNP/PLC	P	Dry=On		89	5			
PNP/PLC	P	Wet=On		86	7			
Relay	D	Dry=On		97	3			
Relay	D	Wet=On		98	3			
Output Type and Model Option Code		Proof-test type	Proof-test type	Proof-test coverage (% of DU)	Remaining dangerous, undetected failures	Test coverage		
						Output circuitry	Measurement electronics	Sensor
2-Wire/Direct-Load	L	Dry=On	Partial	77	11	Yes	Yes	No
2-Wire/Direct-Load	L	Wet=On		77	13			
8 and 16 mA	M	Dry=On		90	3			
8 and 16 mA	M	Dry=On		93	3			
NAMUR	N	Wet=On		89	2			
NAMUR	N	Wet=On		92	3			
PNP/PLC	P	Dry=On		85	7			
PNP/PLC	P	Dry=On		81	10			
Relay	D	Wet=On		96	4			
Relay	D	Wet=On		97	4			

3.7.2 Comprehensive proof-test

The comprehensive proof-test performs a complete test of the system elements. The sensor, measuring electronics and output stage are all checked by virtue of changing of the sensor condition and observation of the output.

The suggested comprehensive proof-test sequence for the Rosemount 2130 is described in [Appendix B: Proposed Comprehensive Proof-test Procedure](#).

3.7.3 Partial proof-test

The level switch has the ability of performing a partial proof-test. This test has reduced diagnostic coverage compared with the comprehensive proof-test, in that it is limited to exercising the output and measurement electronics only.

The partial proof-test presents the following benefits:

- Provides a percentage of the Comprehensive proof-test coverage, enabling the unit to be tested and its effective PFD to be reduced by this percentage at the time of the test.
- See [Appendix D: PFDavg Calculation](#) for an example of benefits on system PFD calculations of partial proof-testing.
- Test can be performed “in-process” and takes less than one minute to complete.
- Provides capability to prolong comprehensive testing to align with standard plant maintenance schedules.
- May give the user the flexibility to schedule the comprehensive proof-testing Interval to fit with a site's scheduled plan.

A suggested partial-proof-test scheme can be found In [Appendix C: Proposed Partial Proof-test Procedure](#).

3.7.4 Proof-test interval

The time intervals for proof-testing are defined by the SIL verification calculation (subject to the PFDavg). The proof-tests must be performed more frequently than or as frequently as specified in the SIL verification calculation in order to maintain the required safety integrity of the overall SIF.

Results from periodic proof-tests shall be recorded and periodically reviewed. For the specification of customer requirements required to fulfill this SIS requirement, please see 61511.

Note

For a valid result, always perform the proof-test on the product media and media conditions that will be stored in the vessel while the device is in operation.

3.7.5 Tools required

- Voltage or current meter, depending on output type
- Power supply
- Safety logic solver

3.7.6 Data required

The date, time and name of the operator that performed, or system that triggered, the proof-test, the response time and result of the proof-test will be documented for maintaining the proof-test history of the device for PFDavg calculations.

3.8 Connection of the level switch to the SIS logicsolver

The Rosemount 2130 Level Switch should be connected to the safety-rated logic solver which is actively performing the safety function as well as automatic diagnostics (if any) designed to diagnose potentially dangerous failures within the level switch. In some cases, it may also be connected directly to the final element.

The Rosemount 2130 Level Switch [Reference Manual](#) gives full installation details for the level switch.

Note

For all product information and documentation downloads, see the on-line Rosemount 2130 web page at Emerson.com/Rosemount.

3.9 General requirements

- The system and function response time shall be less than the process safetytime.
- The level switch will change to its defined safe state in less than this time with relation to the specific hazard scenario.
- All SIS components, including the level switch must be operational before process start-up.
- The user shall verify that the level switch is suitable for use in safety applications by confirming the level switch nameplate and model number are properly marked.
- Personnel performing maintenance and testing on the level switch shall first be assessed as being competent to do so.
- Results from periodic proof tests shall be recorded and periodically reviewed.
- The level switch shall not be operated beyond the useful lifetime as listed in the specification section of the product reference manual without undergoing overhaul or replacement.

Note

For all product information and documentation downloads, see the on-line Rosemount 2130 web page at Emerson.com/Rosemount.

Section 4 Installation and Commissioning

Note

For all product information and documentation downloads, see the on-line Rosemount™ 2130 web page at Emerson.com/Rosemount.

4.1 Safety messages

Procedures and instructions in this section may require special precautions to ensure the safety of the personnel performing the operations. Information that raises potential safety issues is indicated by a warning symbol (). Refer to the following safety messages before performing an operation preceded by this symbol.

WARNING

Failure to follow these guidelines could result in death or serious injury.

Make sure only qualified personnel perform the installation.

Explosions could result in death or serious injury.

- Verify that the operating environment of the level switch is consistent with the appropriate hazardous locations certifications.
- Do not remove the level switch covers in explosive atmospheres when the circuit is alive.
- The level switch cover must be fully engaged to meet explosion-proof requirements.

Electrical shock can result in death or serious injury.

- Avoid contact with the leads and terminals. High voltage that may be present on leads can cause electrical shock.
- Make sure the main power to the level switch is off, and the lines to any other external power source are disconnected or not powered while wiring the level switch.

Note

Customer must follow the “Application limits” on page 7.

4.2 Installation

The Rosemount 2130 Level Switch (“level switch”) must be installed as described in the installation section of the product reference manual. Environmental conditions must not exceed the ratings in the specification section.

The level switch must be accessible for physical inspection.

4.3 Physical location and placement

The level switch shall be accessible with sufficient room for cover removal and electrical connections, and allow for manual proof-testing to take place.

The switch point is determined by the location of the level switch, and consideration must be given to allow the safe proof-testing of the level switch by forcing liquid to put the switch into its Fail-safe state.

4.4 Electrical connections

Wiring should be adequately rated and not be susceptible to mechanical damage. Electrical conduit is commonly used to protect wiring. The wiring to this device must maintain creepage⁽¹⁾ and clearance distances. Therefore, the conductors stripping length should be no greater than 6 mm and be free from stray strands.

1. Creepage distance is a measurement that is commonly used in determining the conducting path of the flow of electricity.

4.5 Configuration

4.5.1 Self-check setting

The Rosemount 2130™ Level Switch must be user-configured to operate in the Self-check mode. This mode enables the internal diagnostic routines.

Self-check mode is indicated by the amber color of the LED on the electronics cassette. SIS-certified 2130 Level Switches (*dependent on model code*) are shipped with this mode pre-configured, but must be checked before first use, and periodically thereafter, as part of the proof-test routine.

4.5.2 Output mode setting

The Rosemount 2130 Level Switch must be user-configured for an application so that the output is ON in the Safe or Normal condition (see Table 4-1).

The response time (seconds delay) may be set to a convenient value to prevent trips that are spurious i.e. not due to a real condition. Note that the Safety Response Time is the greater of 10 seconds and the selected seconds delay using the switch setting (see Table A-1 on page 21).

Table 4-1. Output Mode Setting

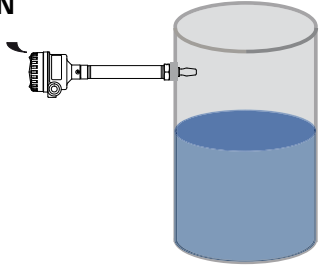
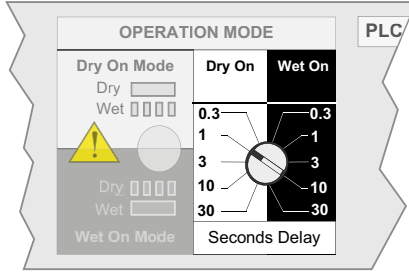
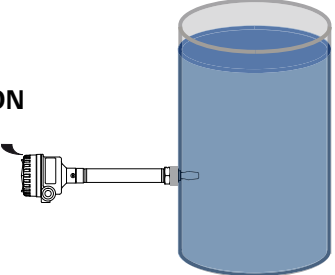
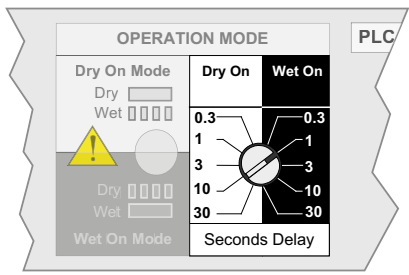
Application	Switch setting (Normal or Safe Condition)
<p style="text-align: center;">High level alarm</p> <p>ON</p> 	<p style="text-align: center;">Dry = On</p> 
<p style="text-align: center;">Low level alarm</p> <p>ON</p> 	<p style="text-align: center;">Wet = On</p> 

Section 5 Operation and Maintenance

5.1 Proof-test requirement

During operation, a low-demand mode SIF must be proof-tested. The objective of proof-testing is to detect failures within the equipment in the SIF that are not detected by any automatic diagnostics of the system. Undetected failures that prevent the SIF from performing its function are the main concern.

Periodic proof-tests shall take place at the frequency (or interval) defined by the SIL verification calculation. The proof-tests must be performed more frequently than or as frequently as specified in the SIL verification calculation in order to maintain the required safety integrity of the overall SIF.

A sample procedure is provided in [Appendix B: Proposed Comprehensive Proof-test Procedure](#). Results from periodic proof-tests shall be recorded and periodically reviewed.

5.2 Repair and replacement

Repair procedures in the Rosemount™ 2130 Level Switch reference manual must be followed.

5.3 Notification of failures

In case of malfunction of the system or SIF, the Rosemount 2130 Level Switch shall be put out of operation and the process shall be kept in a safe state by other measures.

Emerson™ must be informed when the Rosemount 2130 is required to be replaced due to failure. The occurred failure shall be documented and reported to Emerson using the contact details on the back page of this functional safety manual. This is an important part of the Emerson SIS management process.

Appendix A Specifications

A.1 General

In [Table A-1](#), the safety response time for all output types is the greater of 10 seconds or the selected seconds delay using the switch setting.

Note

See [Table 4-1 on page 17](#) for the switch setting feature.

Table A-1. General Specifications

Output type and model option code		Supply voltage	Safety alarm levels (leakage currents) ⁽¹⁾	Safety response time ⁽²⁾	Switch point water ⁽³⁾	Switch point other liquid ⁽⁴⁾
2-Wire/Direct-Load	L	20 to 264 Vac 20 to 60 Vdc	6 mA	10 s minimum	11 to 15 mm	0 to 30 mm
8 and 16 mA	M	11 to 36 Vdc	< 3.7 mA			
NAMUR	N	7 to 9 Vdc	1.0 mA			
PNP/PLC	P	20 to 60 Vdc	< 100 uA			
Relay	D	20 to 60 Vdc 20 to 264 Vac	N/A			

1. Logic solver trip levels should be set higher than these values in order to ensure reliable trips.
2. The safety response time is the greater of 10 seconds or the configured seconds delay using the switch setting. See [Table 4-1 on page 17](#) for details of this setting.
3. Operating (switching) point measured from lowest point of fork when liquid is water.
4. Operating (switching) point measured from lowest point of fork when liquid is not water.

A.2 Useful life

Based on general field failure data and manufactures component data, a useful life period of approximately 10 years is expected for the Rosemount™ 2130 Level Switch at an ambient temperature of 55 °C. This decreases by a factor of two for every increase of 10 °C, and increases by a factor of two for every decrease of 10 °C.

A.3 Useful lifetime

According to the standard IEC 61508-2, a useful lifetime based on experience should be assumed.

Although a constant failure rate is assumed by the probabilistic estimation method (see FMEDA report), this only applies provided that the useful lifetime⁽¹⁾ of components is not exceeded. Beyond their useful lifetime, the result of the probabilistic calculation method is therefore meaningless as the probability of failure significantly increases with time.

The useful lifetime is highly dependent on the subsystem itself and its operating conditions. Specifically, the equipment contains electrolytic capacitors which have a useful life which is highly dependent on ambient temperature (see Safety Data in the FMEDA report).

This assumption of a constant failure rate is based on the bath-tub curve. Therefore, it is obvious that the PFDavg calculation is only valid for components that have this constant domain and that the validity of the calculation is limited to the useful lifetime of each component.

It is the responsibility of the end-user to maintain and operate the Rosemount 2130 Level Switch according to the manufacturer's instructions. Furthermore, regular inspection should show that all components are clean and free from damage.

For high-demand mode applications, the useful lifetime of the mechanical parts is limited by the number of cycles. The useful lifetime of the mechanical and electrical parts is greater than 200000 operations. When plant experience indicates a shorter useful lifetime than indicated, the number based on plant experience should be used.

1. Useful lifetime is a reliability engineering term that describes the operational time interval where the failure rate of a device is relatively constant. It is not a term which covers product obsolescence, warranty, or other commercial issues.

Appendix B Proposed Comprehensive Proof-test Procedure

B.1 Suggested proof-test

According to Section 7.4.5.2 (f) of the standard IEC 61508-2, proof-tests shall be undertaken to reveal dangerous faults which are undetected by diagnostic tests. This means that it is necessary to specify how dangerous undetected faults which have been noted during the failure modes, effects, and diagnostic analysis can be detected during proof-testing.

The suggested proof test for the Rosemount™ 2130 Level Switch is in [Table B-1](#).

Table B-1. Suggested Comprehensive Proof-test (Low Level Alarm)

Step	Action
1	Inspect the accessible parts of the level switch for any leaks or damage.
2	Bypass the safety function and take appropriate action to avoid a false trip.
3	Verify the Mode Switch is set to the required mode of operation.
4	Disable any filling mechanism and drain the vessel to force the switch to the fail-safe state and confirm that the Safe State was achieved and within the correct time as indicated by the setting of the Mode Switch. INDEPENDENT PRECAUTIONS MUST BE TAKEN TO ENSURE THAT NO HAZARD CAN RESULT FROM THIS OPERATION.
5	Reinstate the filling mechanism so that the vessel refills and confirm that the normal operating state of the switch was achieved.
6	Remove the safety function bypass and otherwise restore normal operation.

Table B-2. Suggested Comprehensive Proof-test (High Level Alarm)

Step	Action
1	Inspect the accessible parts of the level switch for any leaks or damage.
2	Bypass the safety function and take appropriate action to avoid a false trip.
3	Verify the Mode Switch is set to the required mode of operation.
4	Disable any drain mechanism and fill the vessel to force the switch to the fail-safe state and confirm that the Safe State was achieved and within the correct time as indicated by the setting of the Mode Switch. INDEPENDENT PRECAUTIONS MUST BE TAKEN TO ENSURE THAT NO HAZARD CAN RESULT FROM THIS OPERATION.
5	Reinstate the drain mechanism so that the vessel refills and confirm that the normal operating state of the switch was achieved.
6	Remove the safety function bypass and otherwise restore normal operation.

B.2 Impact on SIF and process

In order to achieve the product safe state, the sensor must be immersed in the process medium. The process cannot be allowed to operate whilst the proof-test is being performed.

B.3 Duration of comprehensive proof-test

The comprehensive proof-test takes several hours to perform with all safety measures being followed.

B.4 Personal safety concerns

All precautions necessary should be taken during execution of the proof-test.

Appendix C Proposed Partial Proof-test Procedure

C.1 Suggested proof-test

The suggested partial proof-test for the Rosemount™ 2130 Level Switch (“level switch”) is in Table C-1. It exercises the signal processing and output, but does not test the sensor.

Table C-1. Suggested Partial Proof-test (High and Low Level Alarm)

Step	Action
1	Inspect the accessible parts of the level switch for any leaks or damage.
2	Bypass the safety function and take appropriate action to avoid a false trip.
3	Verify the Mode Switch is set to the required mode of operation.
4	Apply a bar magnet to the Magnetic Test Point to force the switch to the fail-safe state and confirm that the Safe State was achieved within two seconds. INDEPENDENT PRECAUTIONS MUST BE TAKEN TO ENSURE THAT NO HAZARD CAN RESULT FROM THIS OPERATION.
5	Remove the bar magnet from the Magnetic Test Point and confirm that after 1s the normal operating state of the switch was achieved.
6	Remove the safety function bypass and otherwise restore normal operation.

C.2 Impact on SIF and process

The process cannot be allowed to operate whilst the proof-test is being performed.

C.3 Duration of partial proof-test

The partial proof-test takes less than an hour to perform with all safety measures being followed.

C.4 Personal safety concerns

All precautions as necessary should be taken during execution of the proof-test.

Appendix D PFDavg Calculation

D.1 Average probability of failure on demand (PFDavg) - 2-Wire/Direct-Load (Dry=On)

The effects of the comprehensive, partial, and combinations of the two proof-test types on PFDavg for the 2-Wire/Direct-Load output type (model code L) in the Dry=On mode, are shown in [Figure D-1 on page 28](#).

The failure rate data used in this calculation is available in the product FMEDA report. A mission time of 10 years has been assumed with a Mean Time To Restoration of 24 hours.

Note

The following figures are purely illustrative and must be performed on a per-SIF basis.

Figure D-1. Effects of Proof-tests on PFD and PFD_{AVG} (2-Wire/Direct-Load, Dry=On)

PFD and PFD average of system when no proof-testing applied

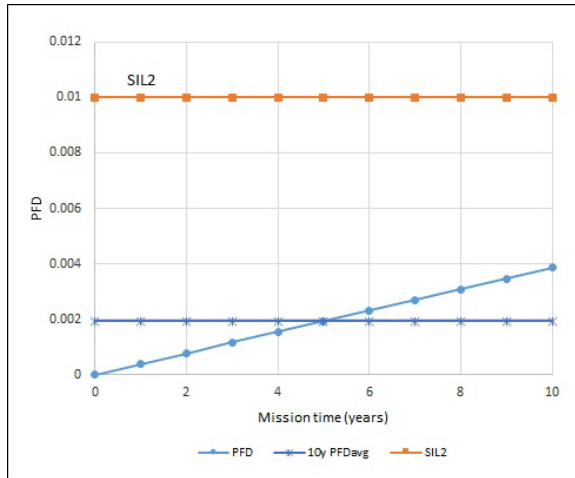

Level switch is subjected to a comprehensive proof-test every five years

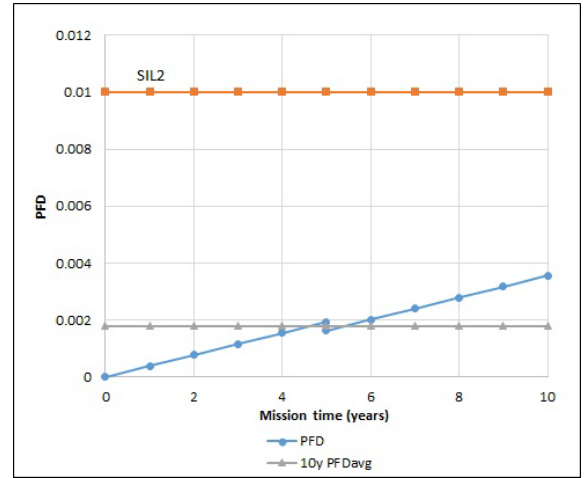

Level switch is subjected to a partial proof-test every year and a comprehensive proof-test every three years

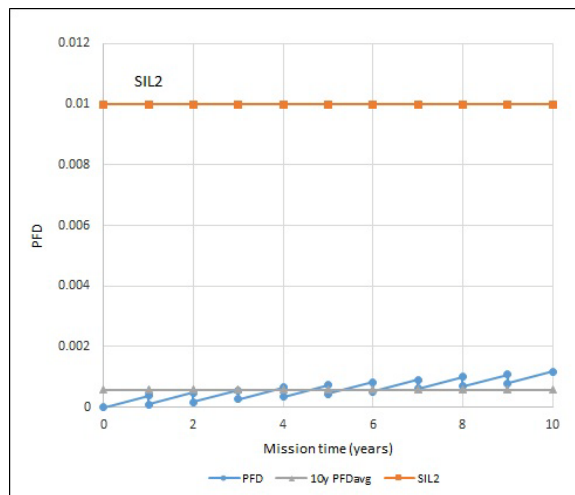

Level switch is subjected to a partial proof-test every year and a comprehensive proof-test every five years

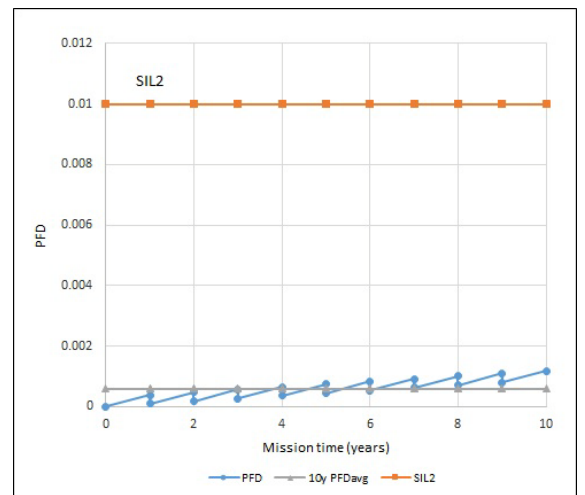
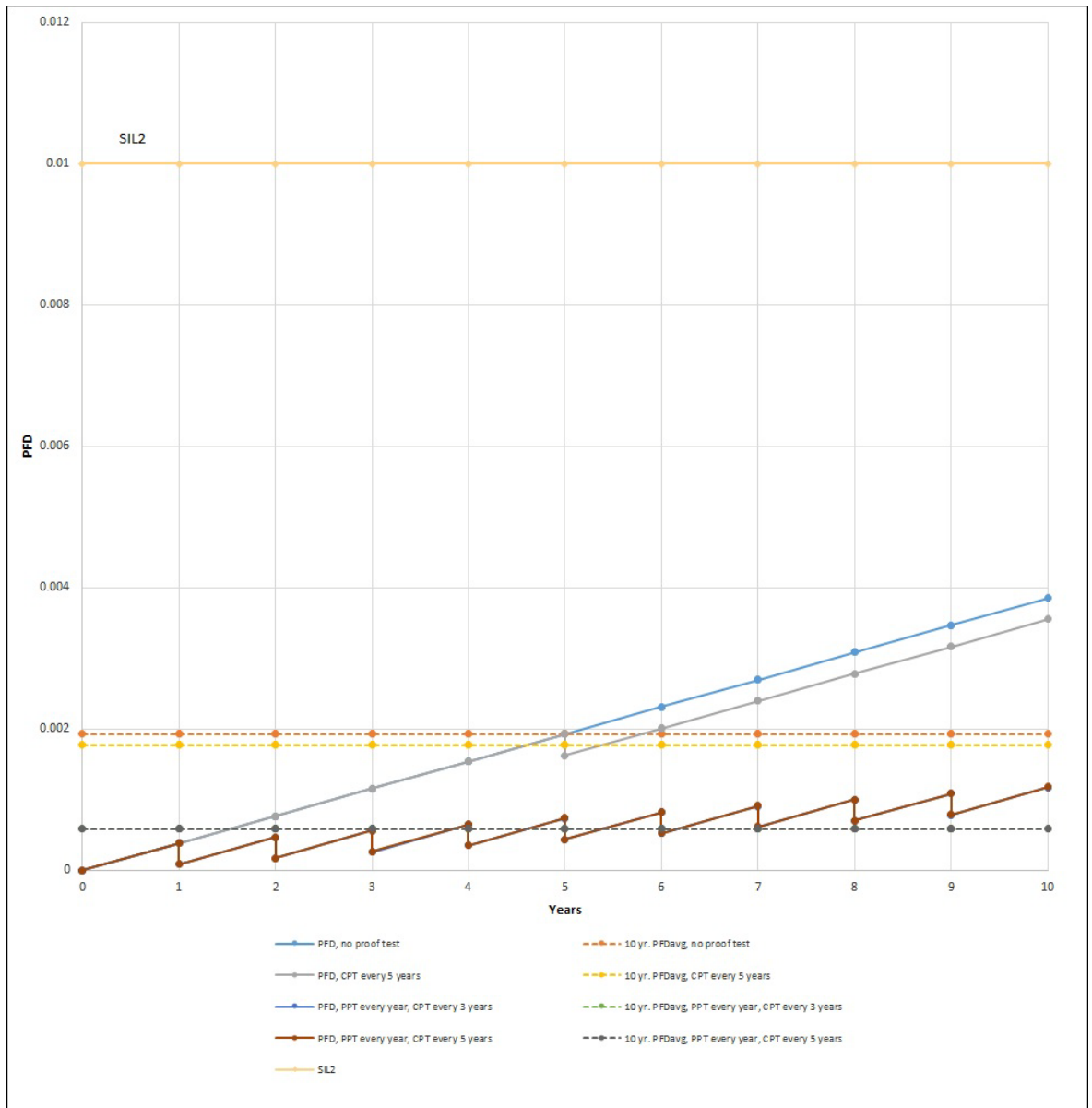

Figure D-2 on page 29 shows the effects of the Full, Partial, and combinations of both proof-test types on PFD and PFD_{AVG} such that the results can be directly compared. Only the final 10 year PFD_{AVG} value is shown. A mission time of 10 years has been assumed with a Mean Time To Restoration of 24 hours.

Note

PFD_{AVG} figures can only be used for Low Demand applications. For High Demand applications, refer to Appendix E: PFH Calculation.

Figure D-2. Comparison of Effects on PFD and PFDavg for Proof-test Types (2-Wire/Direct-Load, Dry=On)



D.2 Average probability of failure on demand (PFD_{AVG}) - 2-Wire/Direct-Load (Wet=On)

The effects of the comprehensive, partial, and combinations of the two proof-test types on PFD_{AVG} for the 2-Wire/Direct-Load output type (model code V) in the Wet=On mode, are shown in Figure D-3.

The failure rate data used in this calculation is available in the product FMEDA report. A mission time of 10 years has been assumed with a Mean Time To Restoration of 24 hours.

Note

The following figures are purely illustrative and must be performed on a per-SIF basis.

Figure D-3. Effects of Proof-tests on PFD and PFD_{AVG} (2-Wire/Direct-Load, Wet=On)

PFD and PFD average of system when no proof-testing applied

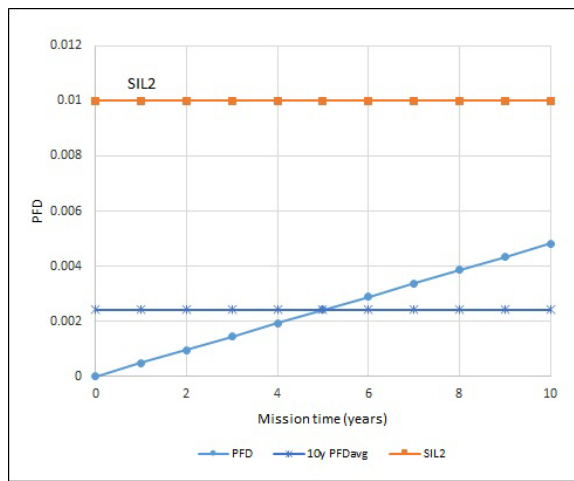

Level switch is subjected to a comprehensive proof-test every five years

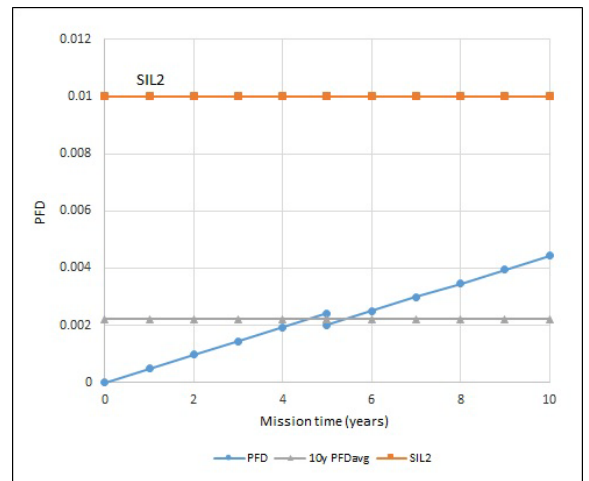

Level switch is subjected to a partial proof-test every year and a comprehensive proof-test every three years

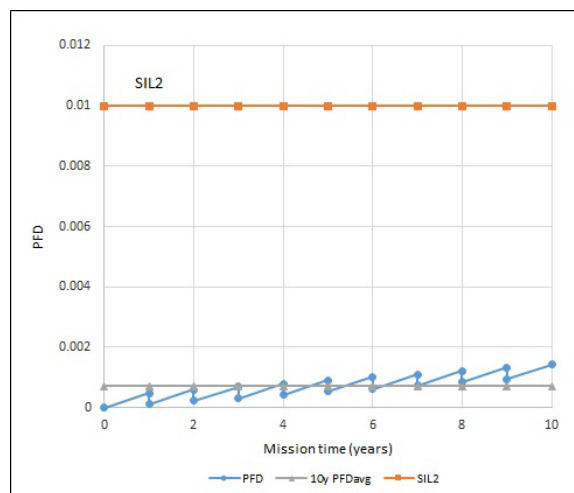

Level switch is subjected to a partial proof-test every year and a comprehensive proof-test every five years

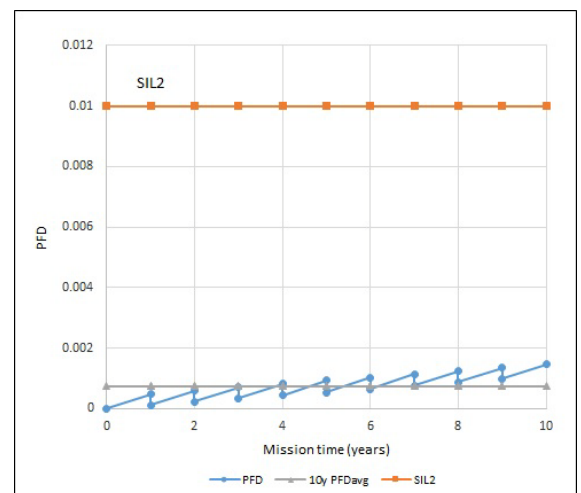
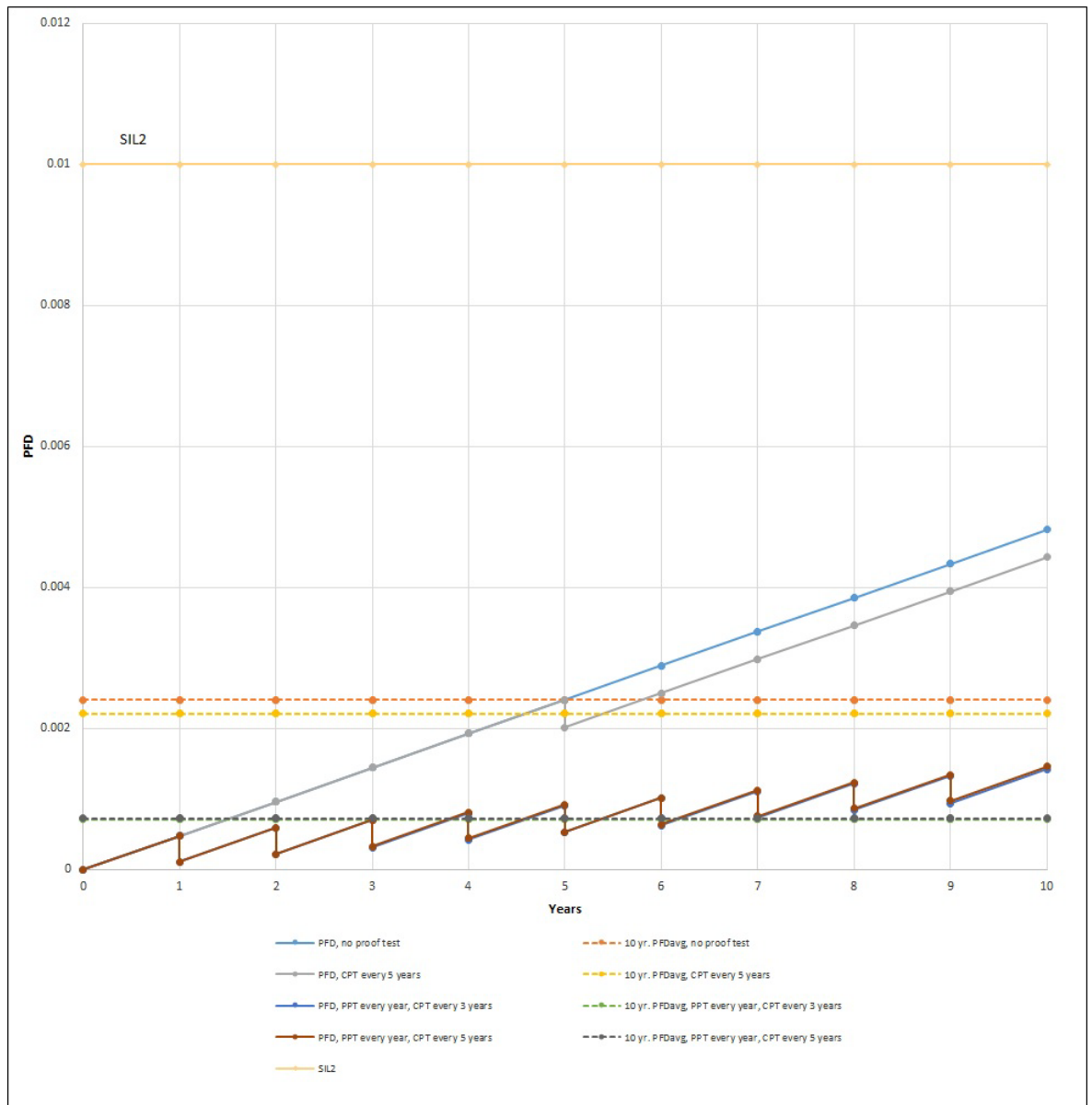

Figure D-4 shows the effects of the Full, Partial, and combinations of both proof-test types on PFD and PFDavg such that the results can be directly compared. Only the final 10 year PFDavg value is shown. A mission time of 10 years has been assumed with a Mean Time To Restoration of 24 hours.

Note

PFDavg figures can only be used for Low Demand applications. For High Demand applications, refer to Appendix E: PFH Calculation.

Figure D-4. Comparison of Effects on PFD and PFDavg for Proof-test Types (2-Wire/Direct-Load, Wet=On)



D.3 Average probability of failure on demand (PFD_{avg}) - 8 and 16 mA (Dry=On)

The effects of the comprehensive, partial, and combinations of the two proof-test types on PFD_{avg} for the 8 and 16 mA output type (model code M) in the Dry=On mode, are shown in Figure D-5.

The failure rate data used in this calculation is available in the product FMEDA report. A mission time of 10 years has been assumed with a Mean Time To Restoration of 24 hours.

Note

The following figures are purely illustrative and must be performed on a per-SIF basis.

Figure D-5. Effects of Proof-tests on PFD and PFD_{AVG} (8 and 16 mA, Dry=On)

PFD and PFD average of system when no proof-testing applied

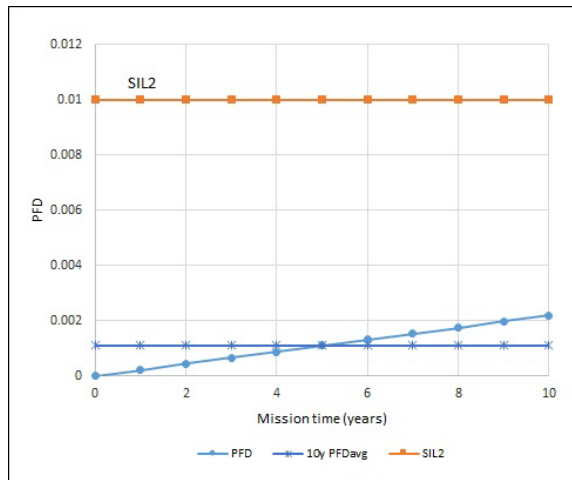

Level switch is subjected to a comprehensive proof-test every five years

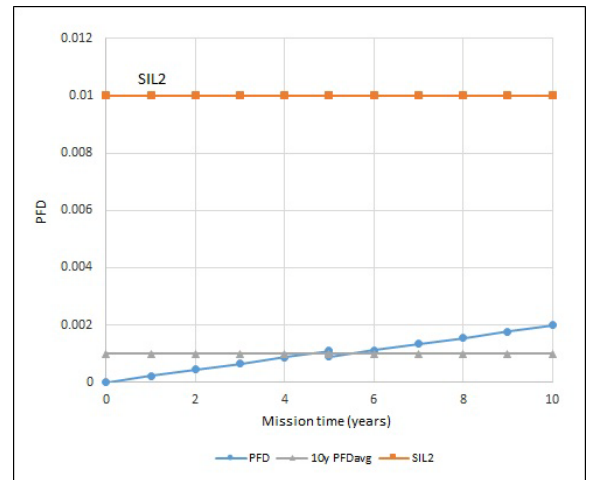

Level switch is subjected to a partial proof-test every year and a comprehensive proof-test every three years

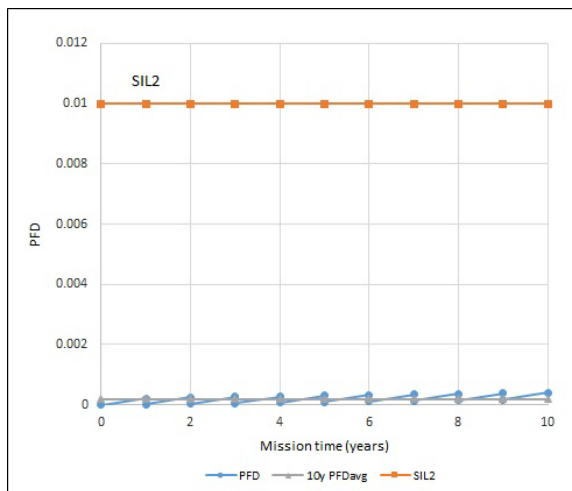

Level switch is subjected to a partial proof-test every year and a comprehensive proof-test every five years

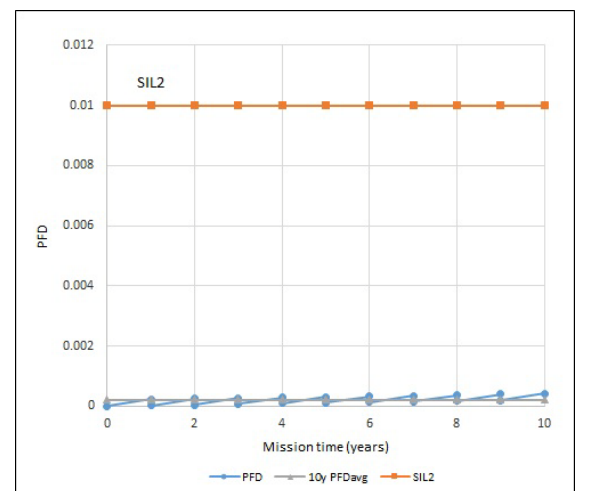
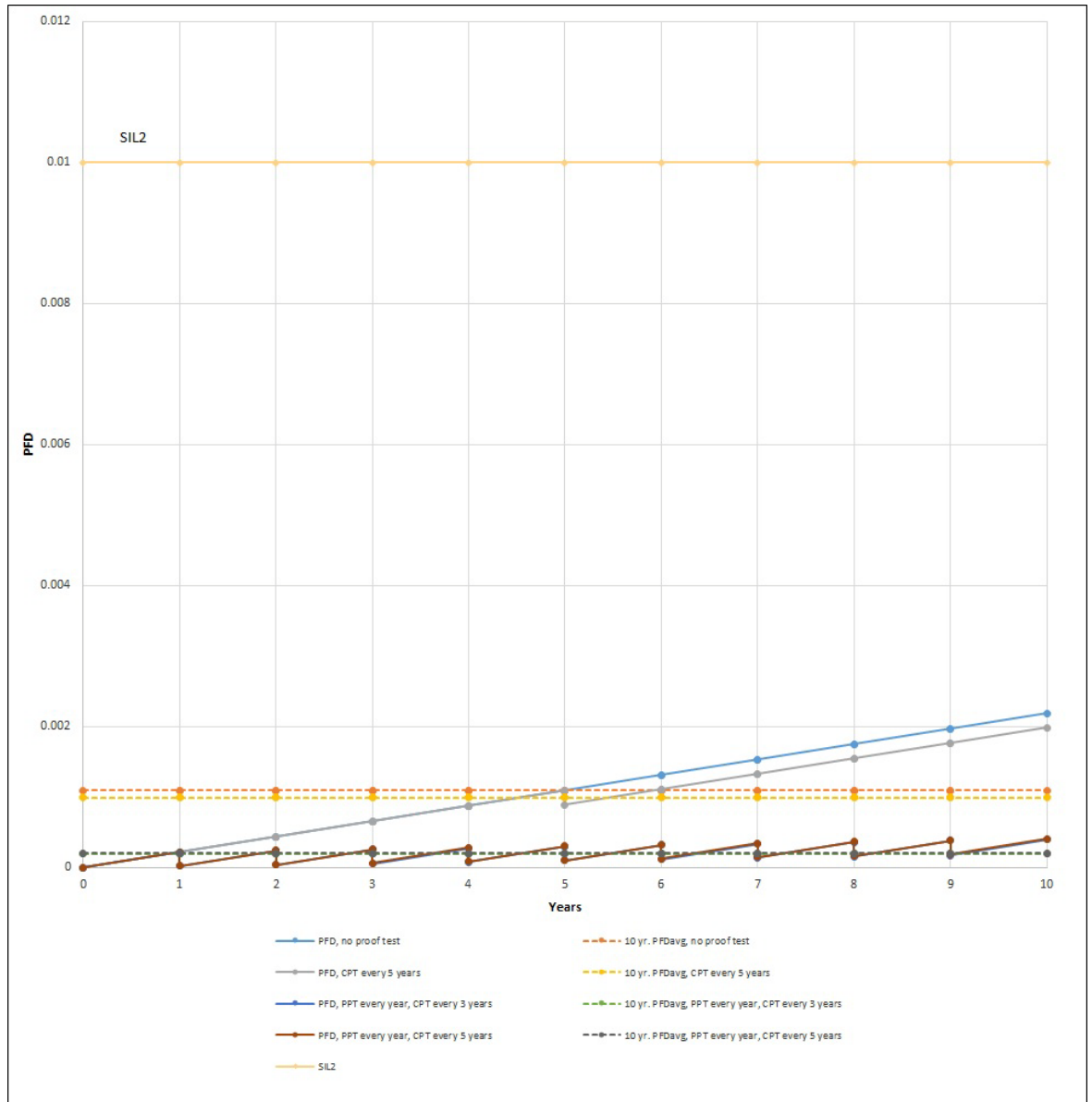

Figure D-6 shows the effects of the Full, Partial, and combinations of both proof-test types on PFD and PFDAvg such that the results can be directly compared. Only the final 10 year PFDAvg value is shown. A mission time of 10 years has been assumed with a Mean Time To Restoration of 24 hours.

Note

PFDAvg figures can only be used for Low Demand applications. For High Demand applications, refer to Appendix E: PFH Calculation.

Figure D-6. Comparison of Effects on PFD and PFDAVG for Proof-test Types (8 and 16 mA, Dry=On)



D.4 Average probability of failure on demand (PFDavg) - 8 and 16 mA (Wet=On)

The effects of the comprehensive, partial, and combinations of the two proof-test types on PFDavg for the 8 and 16 mA output type (model code M) in the Wet=On mode, are shown in Figure D-7.

The failure rate data used in this calculation is available in the product FMEDA report. A mission time of 10 years has been assumed with a Mean Time To Restoration of 24 hours.

Note

The following figures are purely illustrative and must be performed on a per-SIF basis.

Figure D-7. Effects of Proof-tests on PFD and PFD_{AVG} (8 and 16 mA, Wet=On)

PFD and PFD average of system when no proof-testing applied

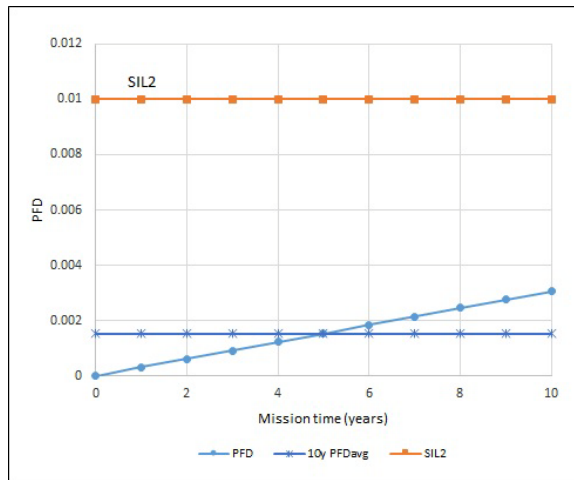

Level switch is subjected to a comprehensive proof-test every five years

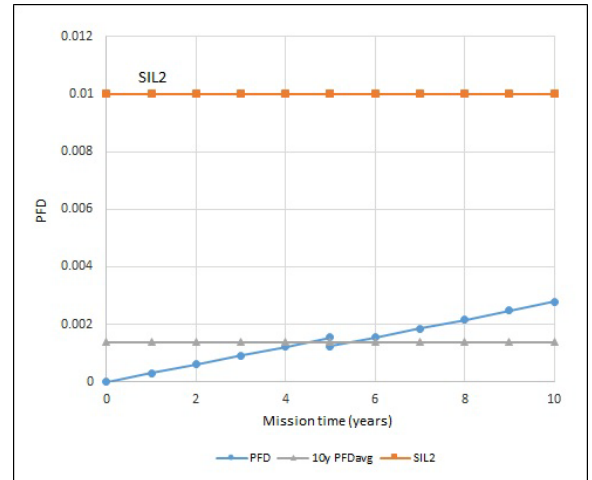

Level switch is subjected to a partial proof-test every year and a comprehensive proof-test every three years

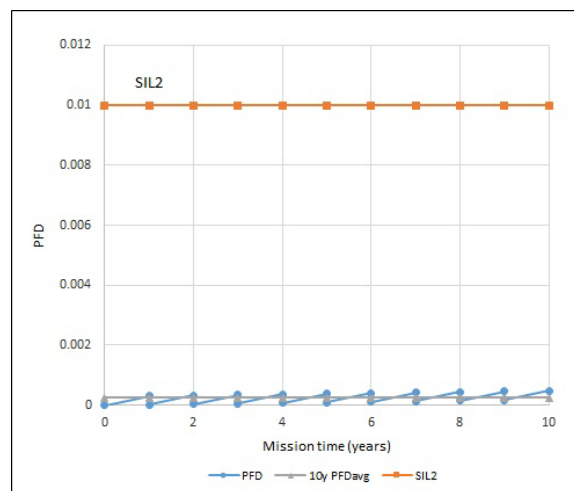

Level switch is subjected to a partial proof-test every year and a comprehensive proof-test every five years

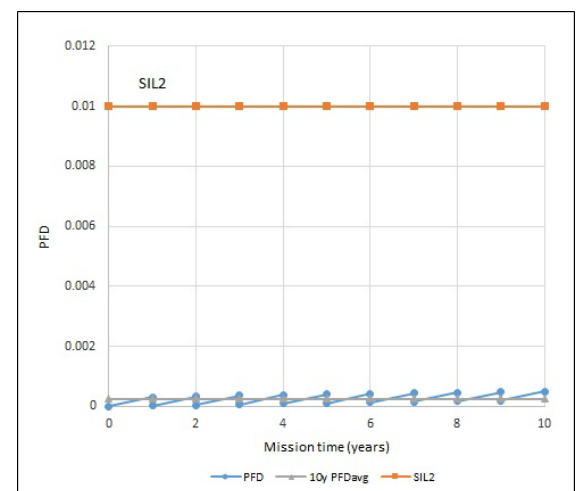
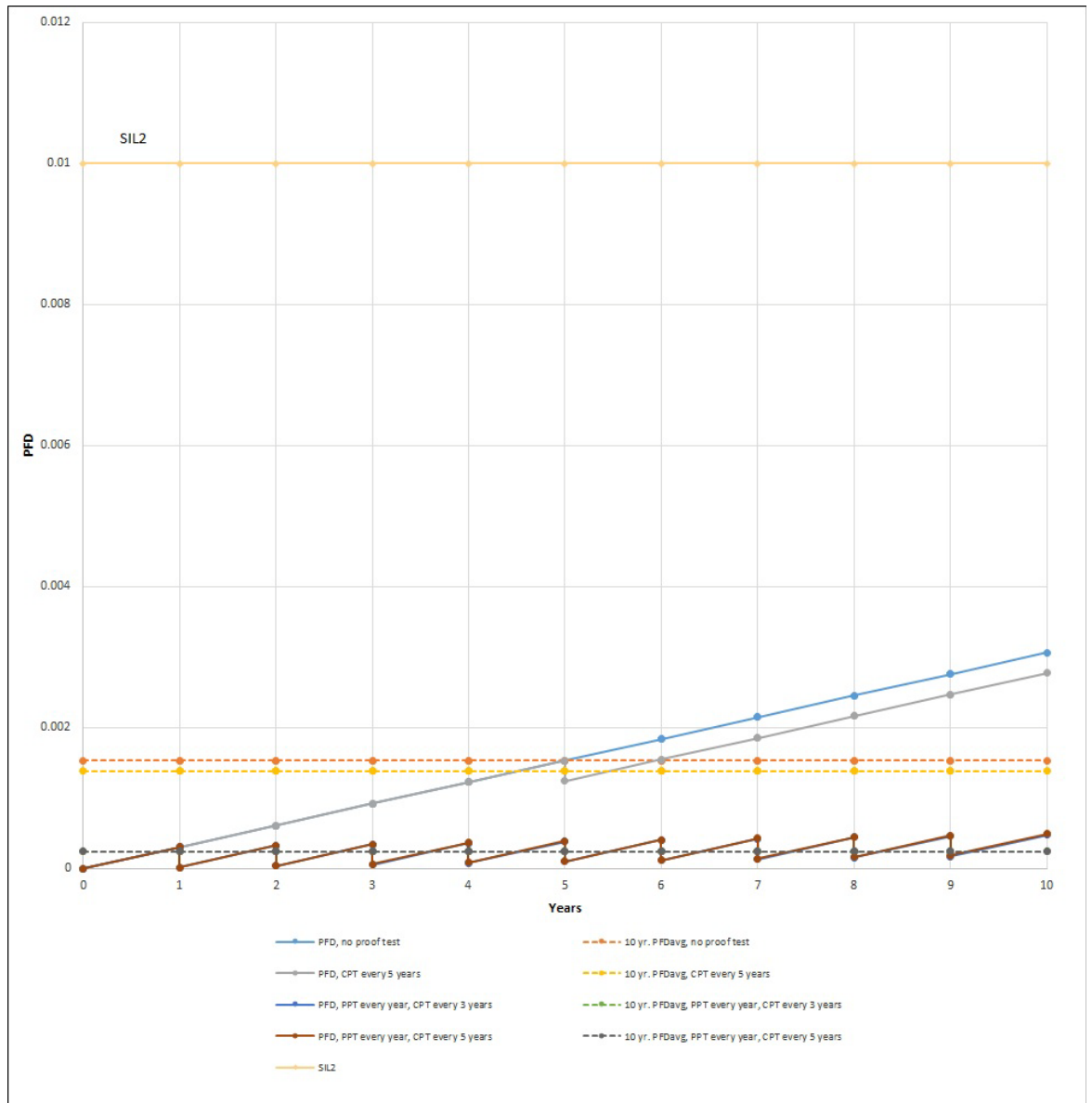

Figure D-8 shows the effects of the Full, Partial, and combinations of both proof-test types on PFD and PFDavg such that the results can be directly compared. Only the final 10 year PFDavg value is shown. A mission time of 10 years has been assumed with a Mean Time To Restoration of 24 hours.

Note

PFDavg figures can only be used for Low Demand applications. For High Demand applications, refer to Appendix E: PFH Calculation.

Figure D-8. Comparison of Effects on PFD and PFDavg for Proof-test Types (8 and 16 mA, Wet=On)



D.5 Average probability of failure on demand (PFDavg) - NAMUR (Dry=On)

The effects of the comprehensive, partial, and combinations of the two proof-test types on PFDavg for the NAMUR output type (model code N) in the Dry=On mode, are shown in Figure D-9.

The failure rate data used in this calculation is available in the product FMEDA report. A mission time of 10 years has been assumed with a Mean Time To Restoration of 24 hours.

Note

The following figures are purely illustrative and must be performed on a per-SIF basis.

Figure D-9. Effects of Proof-tests on PFD and PFD_{AVG} (NAMUR, Dry=On)

PFD and PFD average of system when no proof-testing applied

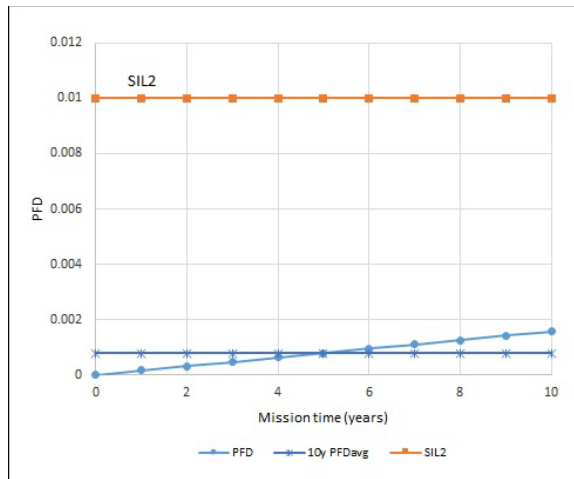

Level switch is subjected to a comprehensive proof-test every five years

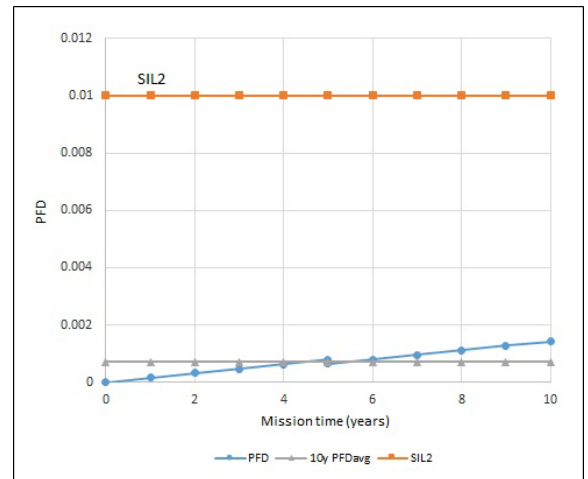

Level switch is subjected to a partial proof-test every year and a comprehensive proof-test every three years

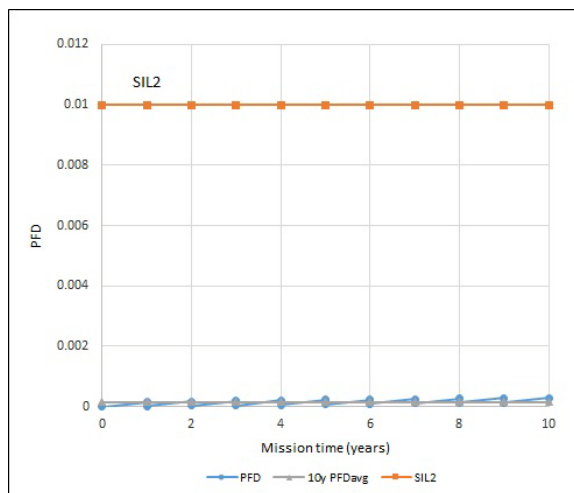

Level switch is subjected to a partial proof-test every year and a comprehensive proof-test every five years

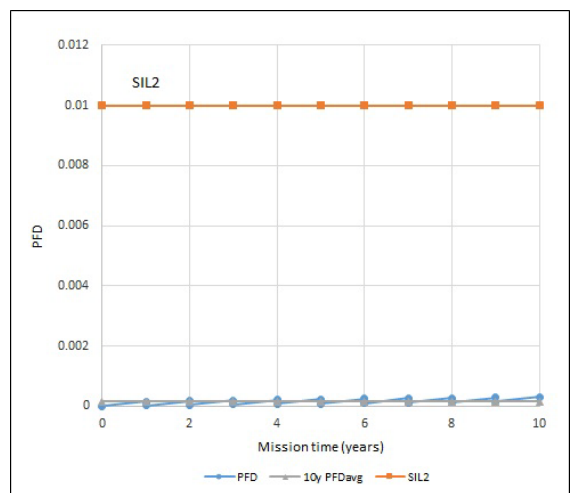
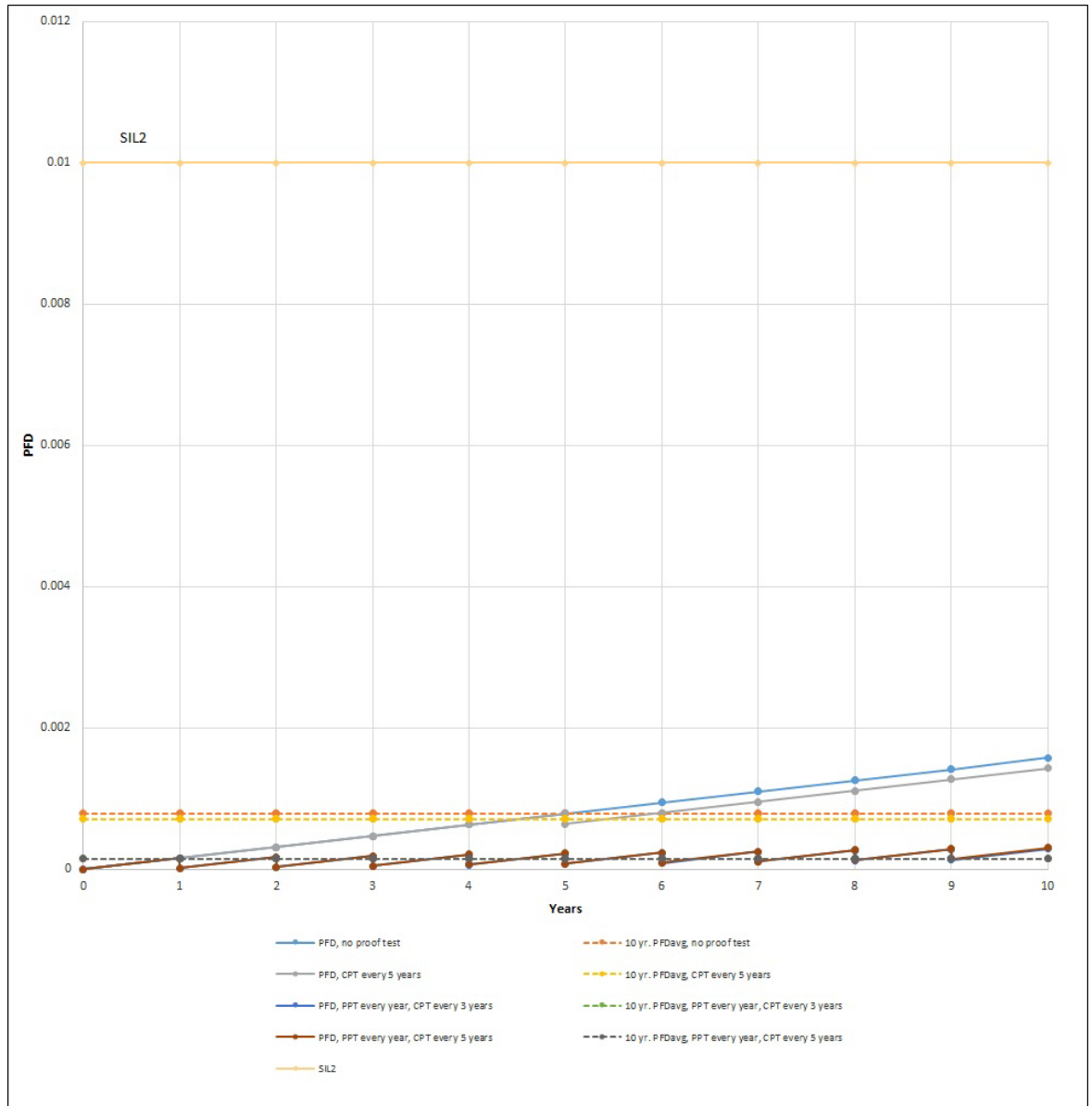

Figure D-10 shows the effects of the Full, Partial, and combinations of both proof-test types on PFD and PFDAVG such that the results can be directly compared. Only the final 10 year PFDAVG value is shown. A mission time of 10 years has been assumed with a Mean Time To Restoration of 24 hours.

Note

PFDAVG figures can only be used for Low Demand applications. For High Demand applications, refer to Appendix E: PFH Calculation.

Figure D-10. Comparison of Effects on PFD and PFDAVG for Proof-test Types (NAMUR, Dry=On)



D.6 Average probability of failure on demand (PFDavg) - NAMUR (Wet=On)

The effects of the comprehensive, partial, and combinations of the two proof-test types on PFDavg for the NAMUR output type (model code N) in the Wet=On mode, are shown in Figure D-11.

The failure rate data used in this calculation is available in the product FMEDA report. A mission time of 10 years has been assumed with a Mean Time To Restoration of 24 hours.

Note

The following figures are purely illustrative and must be performed on a per-SIF basis.

Figure D-11. Effects of Proof-tests on PFD and PFD_{AVG} (NAMUR, Wet=On)

PFD and PFD average of system when no proof-testing applied

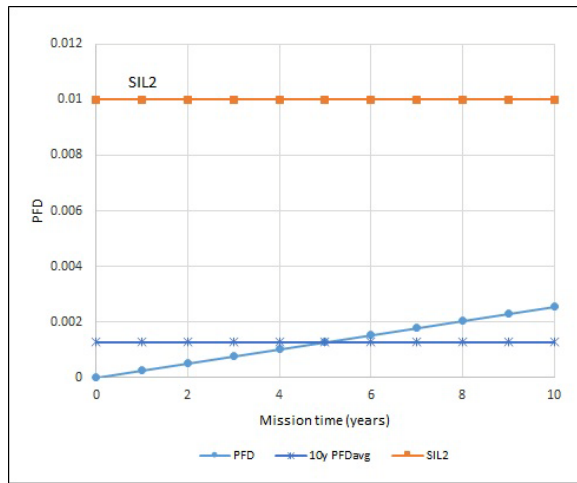

Level switch is subjected to a comprehensive proof-test every five years

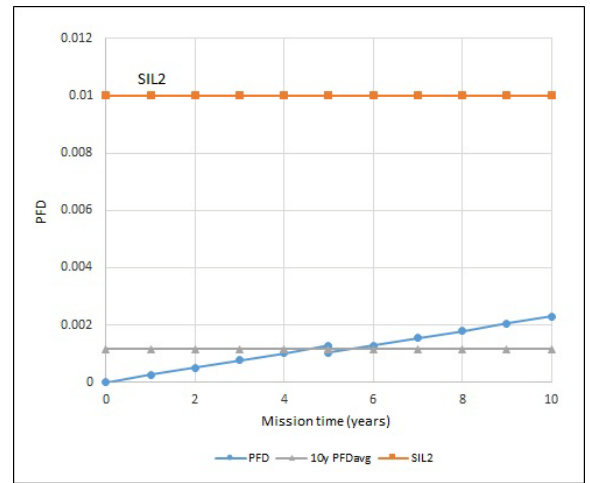

Level switch is subjected to a partial proof-test every year and a comprehensive proof-test every five years

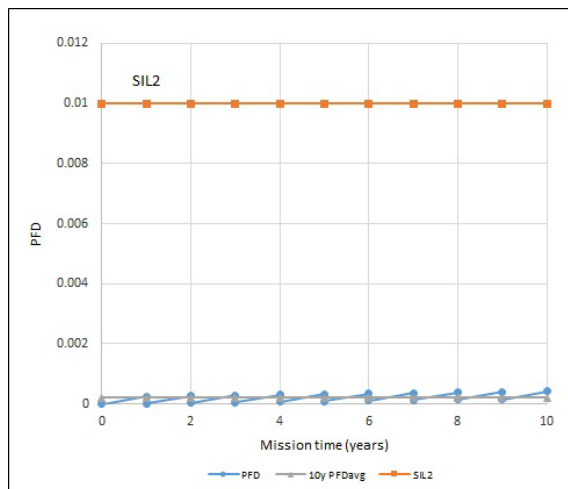

Level switch is subjected to a partial proof-test every year and a comprehensive proof-test every five years

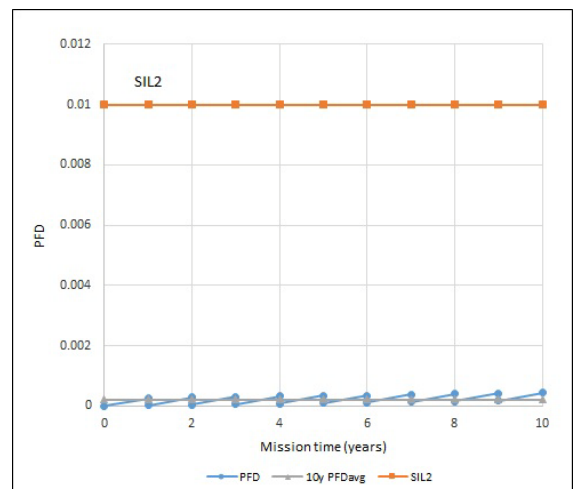
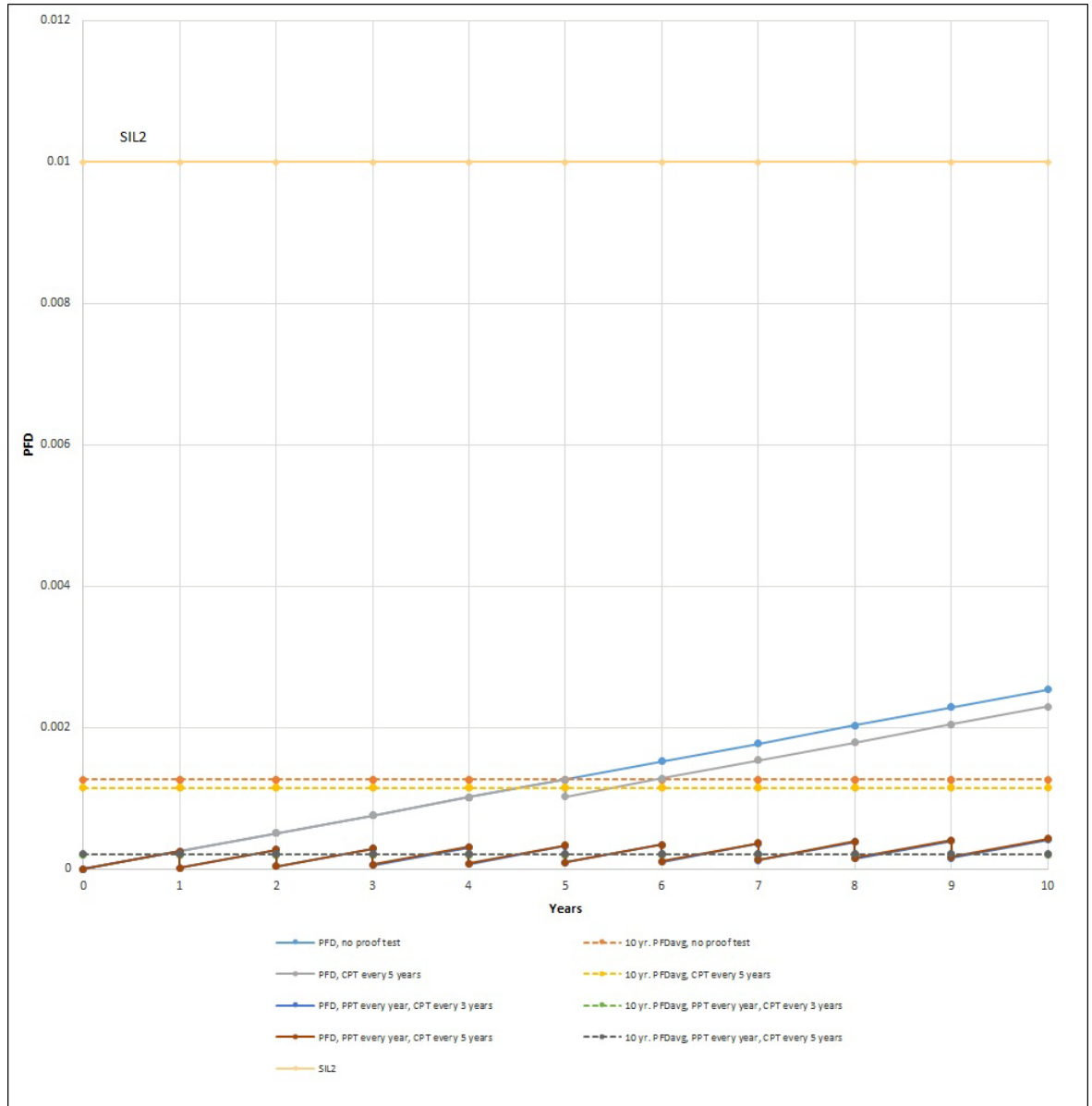

Figure D-12 shows the effects of the Full, Partial, and combinations of both proof-test types on PFD and PFDavg such that the results can be directly compared. Only the final 10 year PFDavg value is shown. A mission time of 10 years has been assumed with a Mean Time To Restoration of 24 hours.

Note

PFDavg figures can only be used for Low Demand applications. For High Demand applications, refer to Appendix E: PFH Calculation.

Figure D-12. Comparison of Effects on PFD and PFDavg for Proof-test Types (NAMUR, Wet=On)



D.7 Average probability of failure on demand (PFDavg) - PNP/PLC (Dry=On)

The effects of the comprehensive, partial, and combinations of the two proof-test types on PFDavg for the PNP/PLC output type (model code P) in the Dry=On mode are shown in Figure D-13.

The failure rate data used in this calculation is available in the product FMEDA report. A mission time of 10 years has been assumed with a Mean Time To Restoration of 24 hours.

Note

The following figures are purely illustrative and must be performed on a per-SIF basis.

Figure D-13. Effects of Proof-tests on PFD and PFD_{AVG} (PNP/PLC, Dry=On)

PFD and PFD average of system when no proof-testing applied

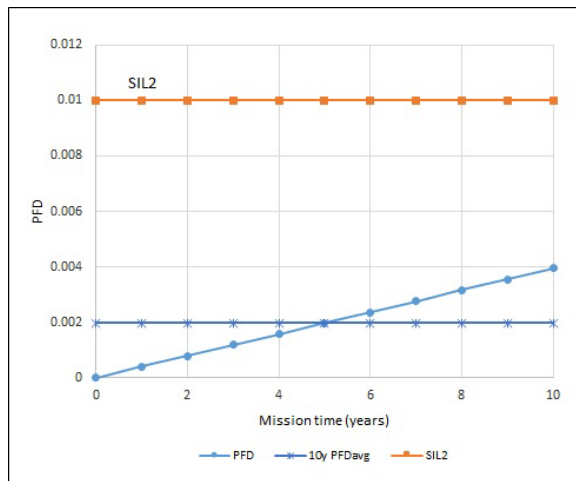

Level switch is subjected to a comprehensive proof-test every five years

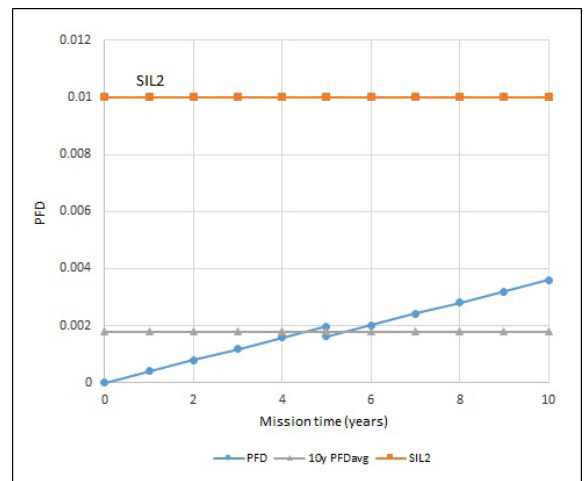

Level switch is subjected to a partial proof-test every year and a comprehensive proof-test every three years

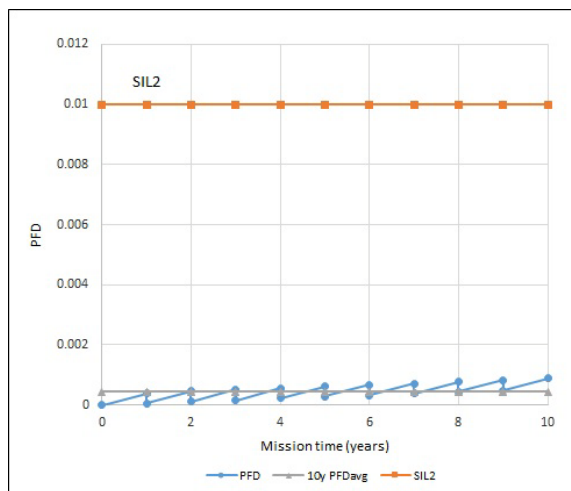

Level switch is subjected to a partial proof-test every year and a comprehensive proof-test every five years

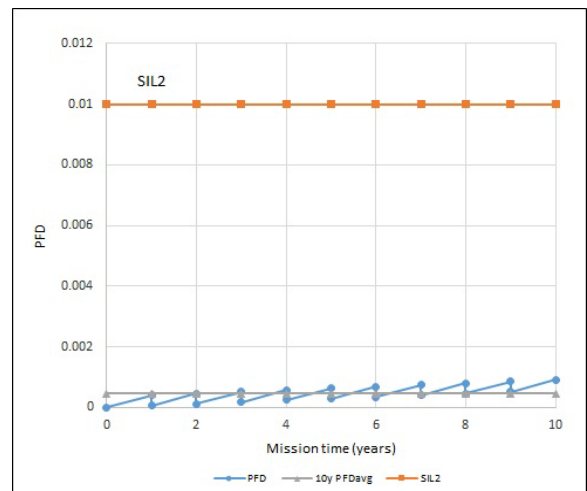
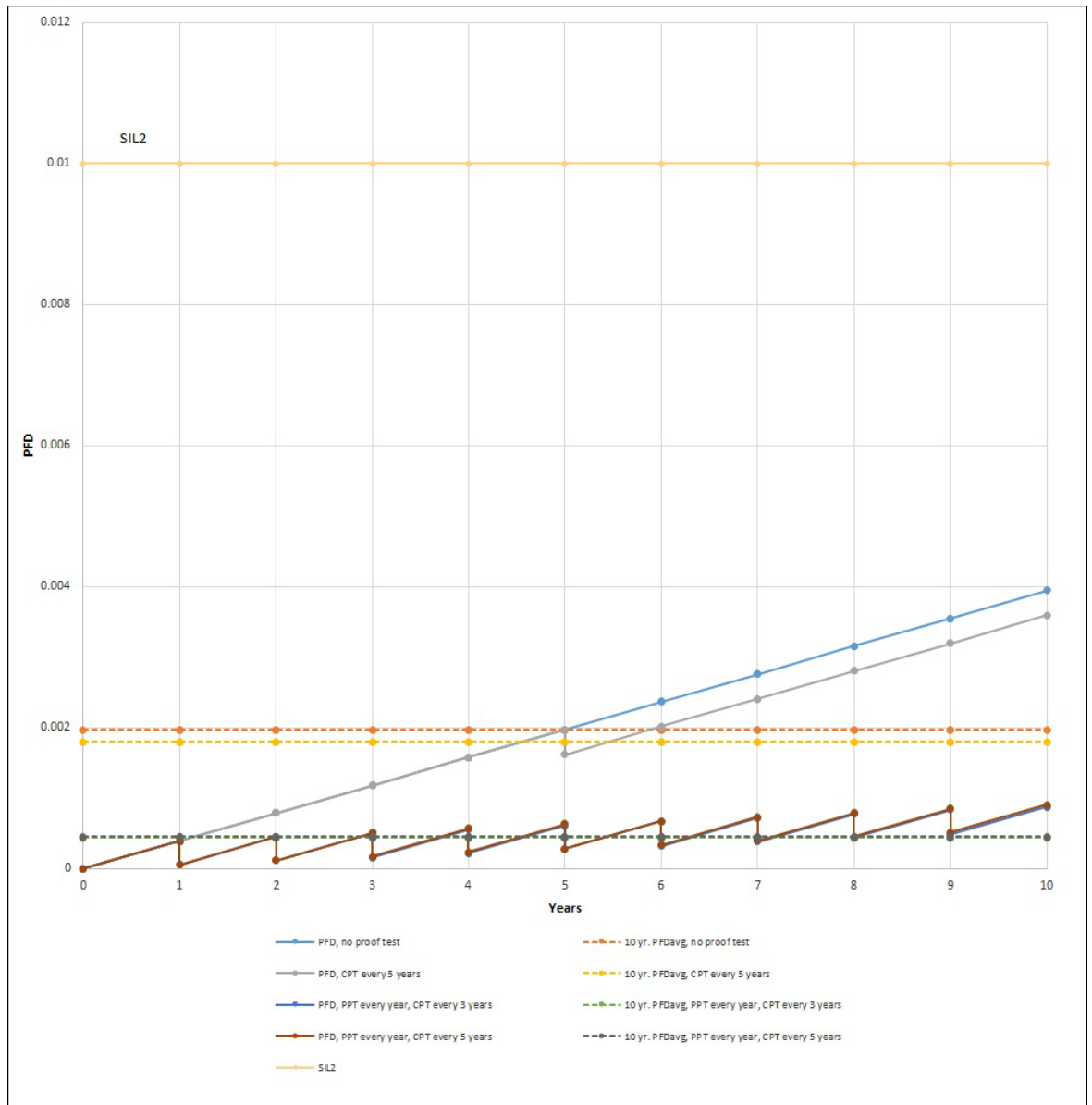

Figure D-14 shows the effects of the Full, Partial, and combinations of both proof-test types on PFD and PFDavg such that the results can be directly compared. Only the final 10 year PFDavg value is shown. A mission time of 10 years has been assumed with a Mean Time To Restoration of 24 hours.

Note

PFDavg figures can only be used for Low Demand applications. For High Demand applications, refer to Appendix E: PFH Calculation.

Figure D-14. Comparison of Effects on PFD and PFDavg for Proof-test Types (PNP/PLC, Dry=On)



D.8 Average probability of failure on demand (PFDavg) - PNP/PLC (Wet=On)

The effects of the comprehensive, partial, and combinations of the two proof-test types on PFDavg for the PNP/PLC output type (model code P) in the Wet=On mode are shown in Figure D-15.

The failure rate data used in this calculation is available in the product FMEDA report. A mission time of 10 years has been assumed with a Mean Time To Restoration of 24 hours.

Note

The following figures are purely illustrative and must be performed on a per-SIF basis.

Figure D-15. Effects of Proof-tests on PFD and PFD_{AVG} (PNP/PLC, Wet=On)

PFD and PFD average of system when no proof-testing applied

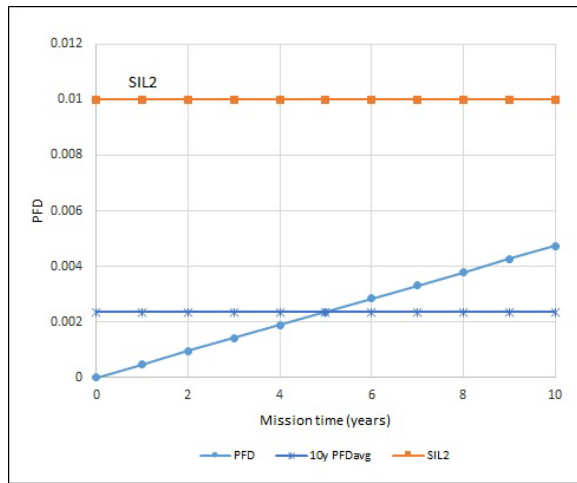

Level switch is subjected to a comprehensive proof-test every five years

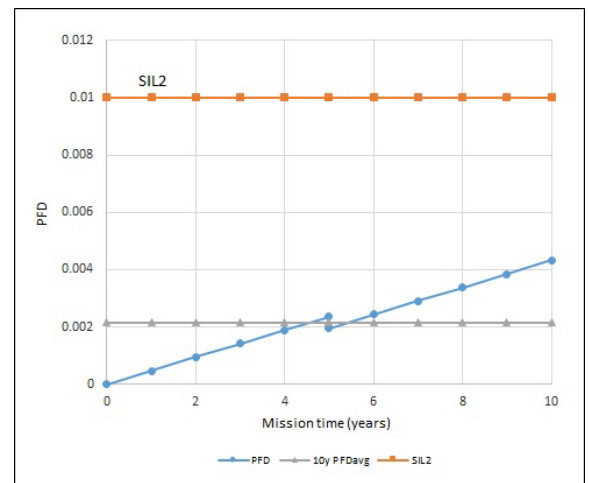

Level switch is subjected to a partial proof-test every year and a comprehensive proof-test every three years

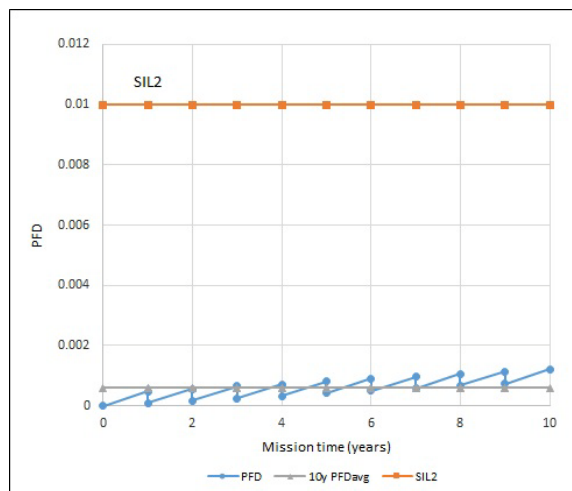

Level switch is subjected to a partial proof-test every year and a comprehensive proof-test every five years

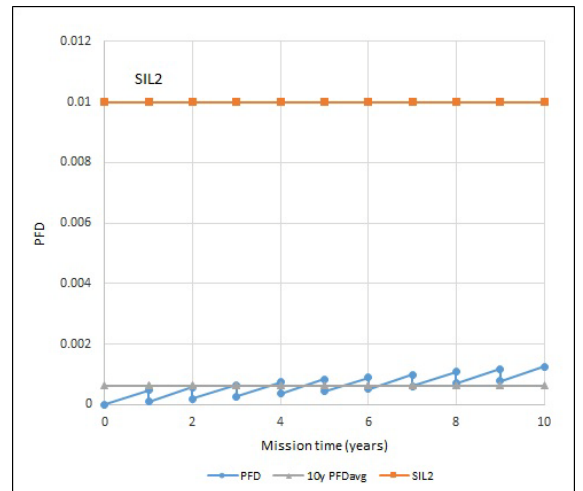
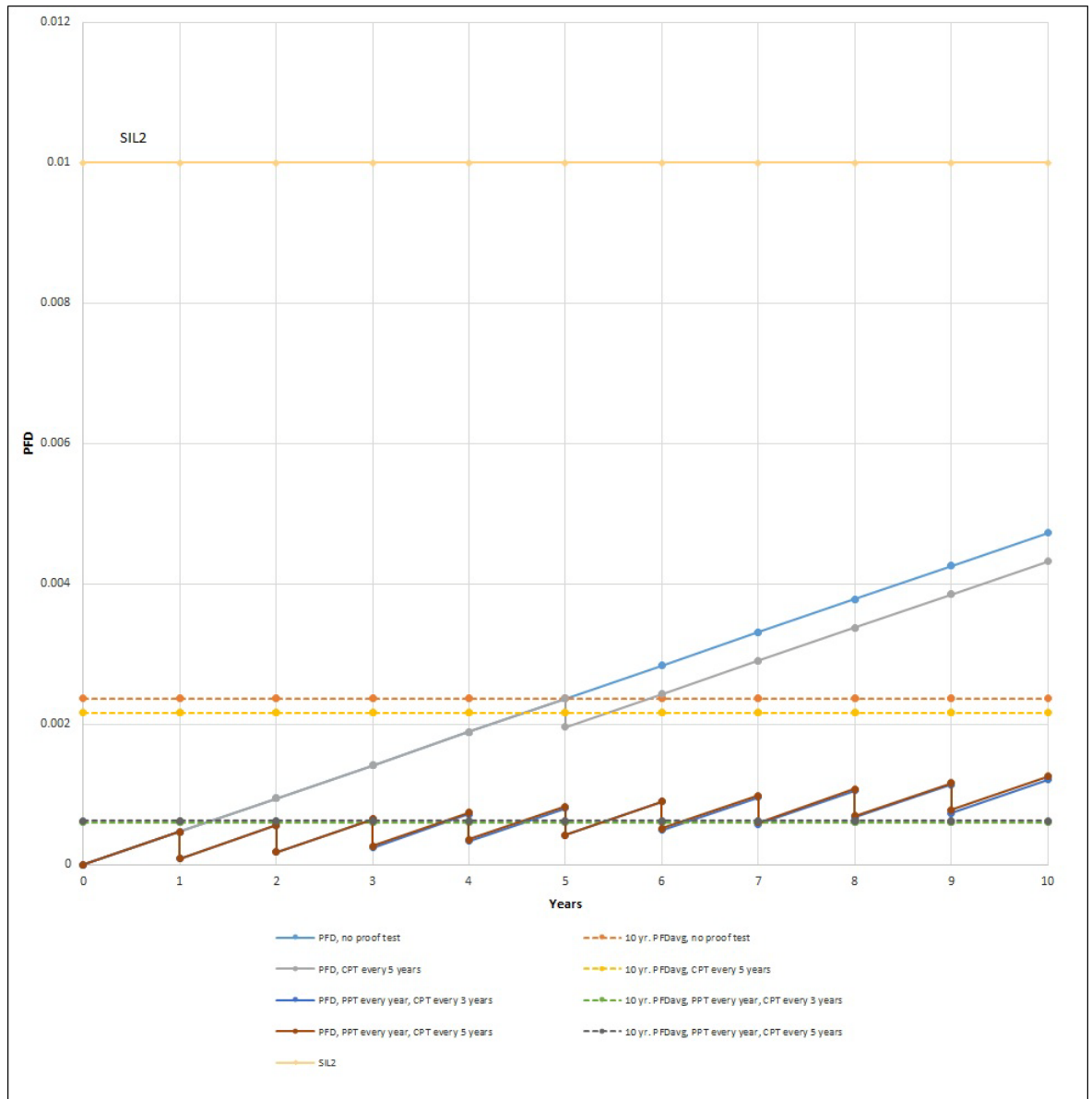

Figure D-16 shows the effects of the Full, Partial, and combinations of both proof-test types on PFD and PFDAvg such that the results can be directly compared. Only the final 10 year PFDAvg value is shown. A mission time of 10 years has been assumed with a Mean Time To Restoration of 24 hours.

Note

PFDAvg figures can only be used for Low Demand applications. For High Demand applications, refer to Appendix E: PFH Calculation.

Figure D-16. Comparison of Effects on PFD and PFDAVG for Proof-test Types (PNP/PLC, Wet=On)



D.9 Average probability of failure on demand (PFDavg) - Relay (Dry=On)

The effects of the comprehensive, partial, and combinations of the two proof-test types on PFDavg for the Relay output type (model code D) in the Dry=On mode are shown in Figure D-17.

The failure rate data used in this calculation is available in the product FMEDA report. A mission time of 10 years has been assumed with a Mean Time To Restoration of 24 hours.

Note

The following figures are purely illustrative and must be performed on a per-SIF basis.

Figure D-17. Effects of Proof-tests on PFD and PFD_{AVG} (Relay, Dry=On)

PFD and PFD average of system when no proof-testing applied

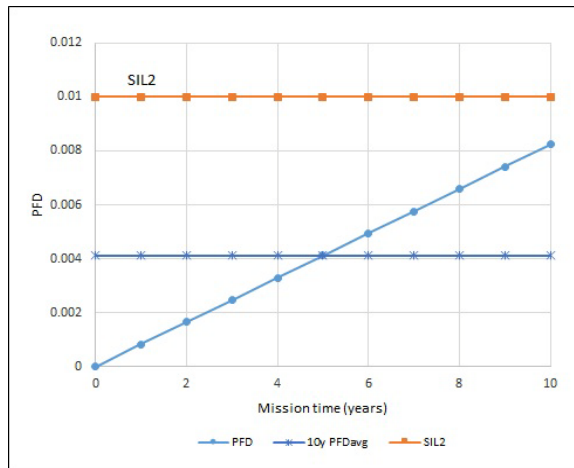

Level switch is subjected to a comprehensive proof-test every five years

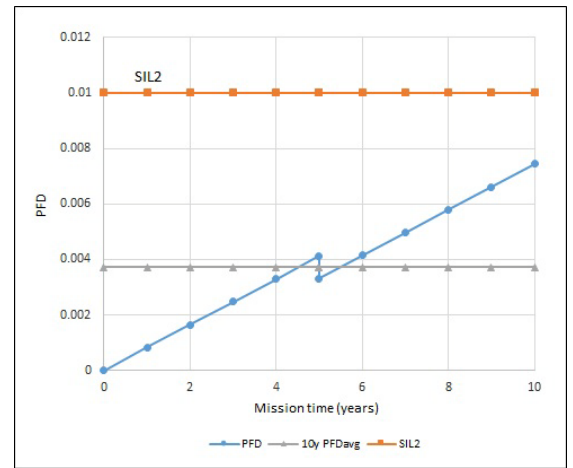

Level switch is subjected to a partial proof-test every year and a comprehensive proof-test every three years

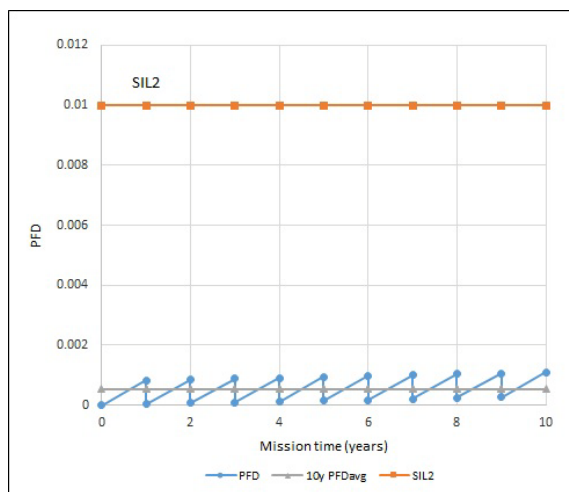

Level switch is subjected to a partial proof-test every year and a comprehensive proof-test every five years

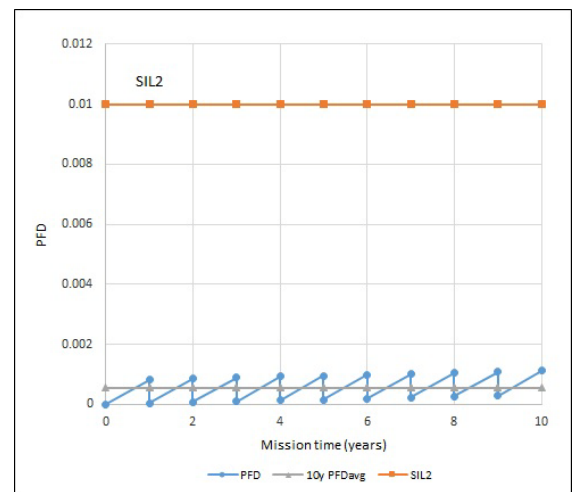
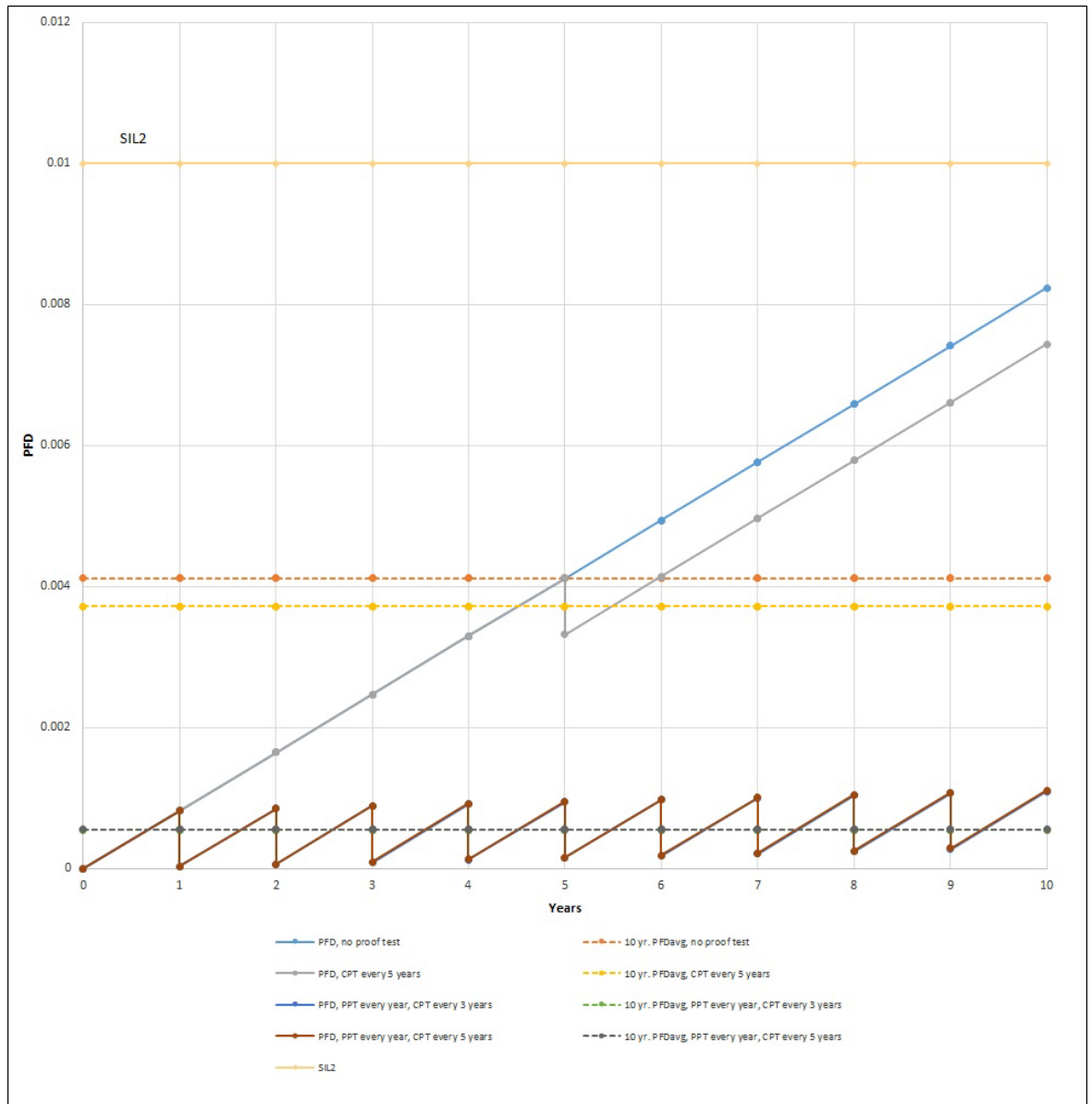

Figure D-18 shows the effects of the Full, Partial, and combinations of both proof-test types on PFD and PFDavg such that the results can be directly compared. Only the final 10 year PFDavg value is shown. A mission time of 10 years has been assumed with a Mean Time To Restoration of 24 hours.

Note

PFDavg figures can only be used for Low Demand applications. For High Demand applications, refer to Appendix E: PFH Calculation.

Figure D-18. Comparison of Effects on PFD and PFDavg for Proof-test Types (Relay, Dry=On)



D.10 Average probability of failure on demand (PFDavg) - Relay (Wet=On)

The effects of the comprehensive, partial, and combinations of the two proof-test types on PFDavg for the Relay output type (model code D) in the Wet=On mode, are shown in Figure D-19.

The failure rate data used in this calculation is available in the product FMEDA report. A mission time of 10 years has been assumed with a Mean Time To Restoration of 24 hours.

Note

The following figures are purely illustrative and must be performed on a per-SIF basis.

Figure D-19. Effects of Proof-tests on PFD and PFD_{AVG} (Relay, Wet=On)

PFD and PFD average of system when no proof-testing applied

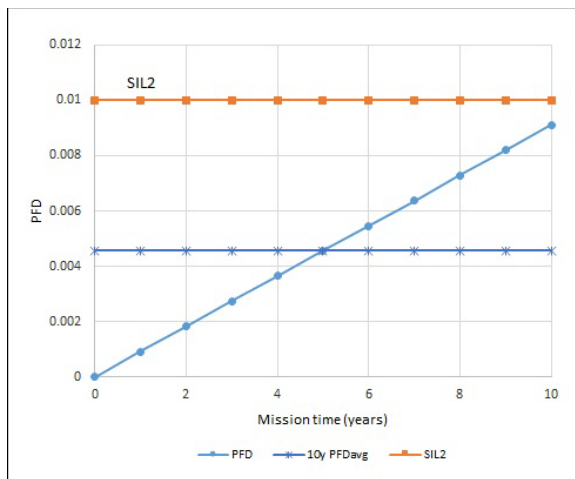

Level switch is subjected to a comprehensive proof-test every five years

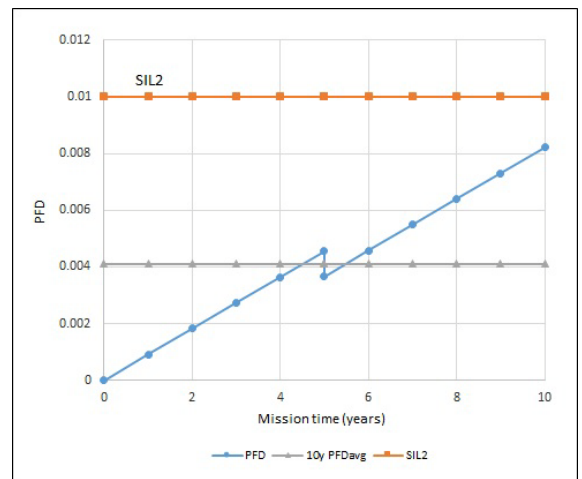

Level switch is subjected to a partial proof-test every year and a comprehensive proof-test every three years

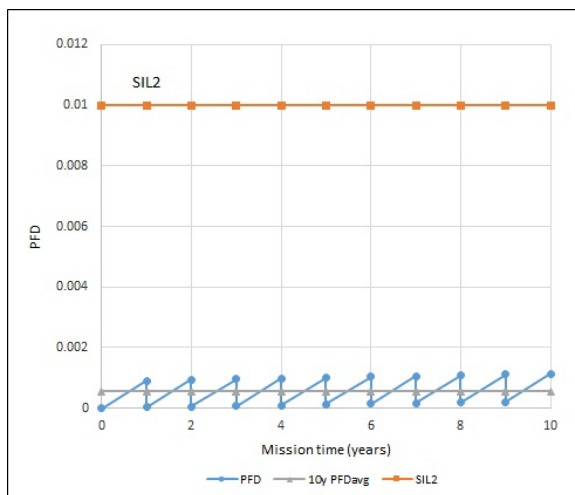

Level switch is subjected to a partial proof-test every year and a comprehensive proof-test every five years

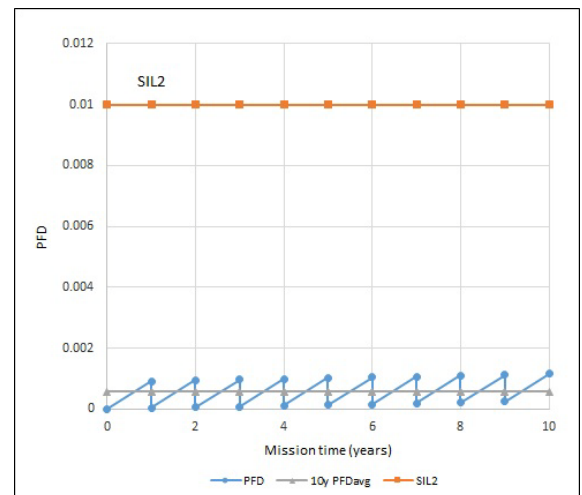
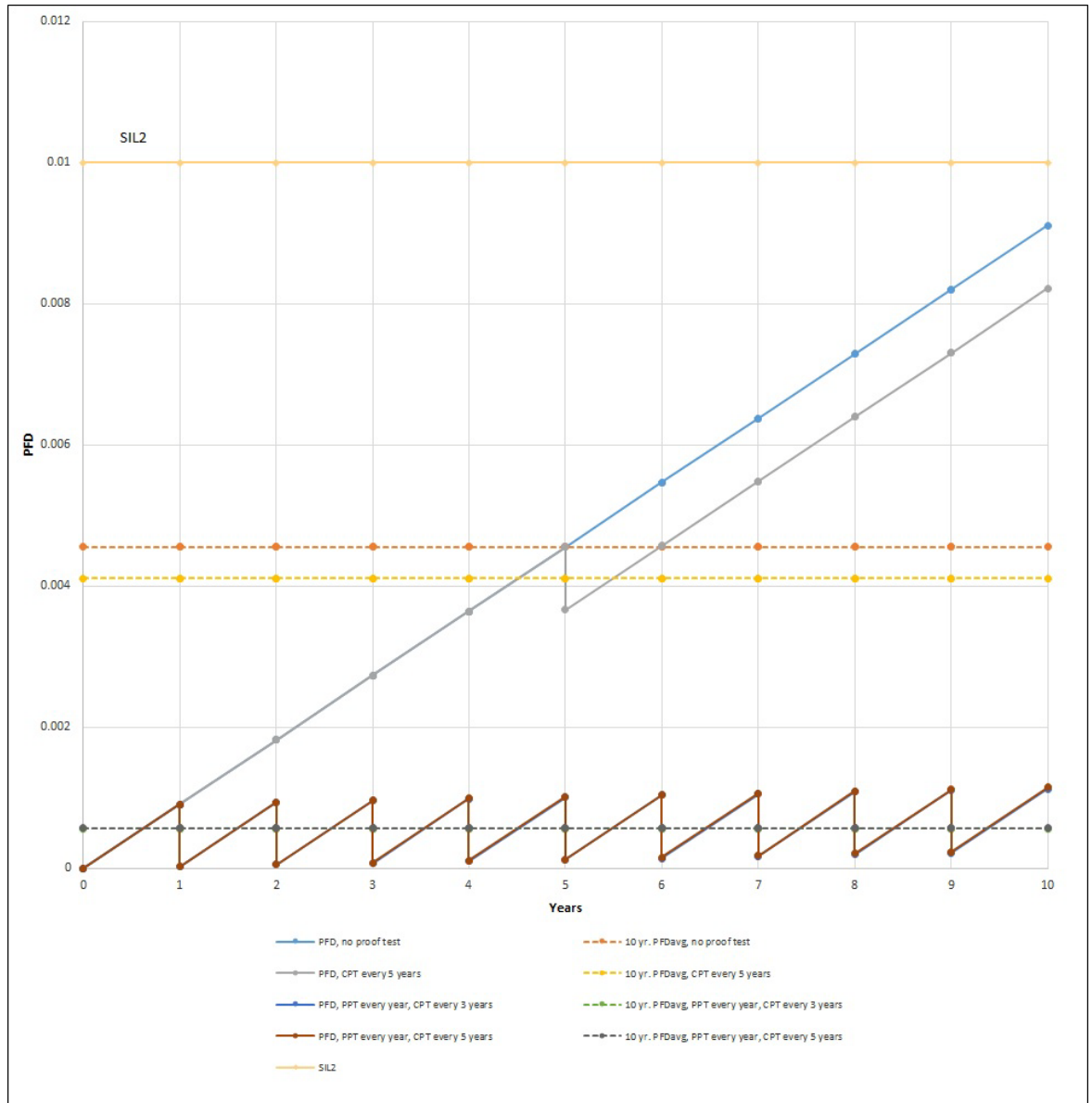

Figure D-20 shows the effects of the Full, Partial, and combinations of both proof-test types on PFD and PFDAvg such that the results can be directly compared. Only the final 10 year PFDAvg value is shown. A mission time of 10 years has been assumed with a Mean Time To Restoration of 24 hours.

Note

PFDAvg figures can only be used for Low Demand applications. For High Demand applications, refer to Appendix E: PFH Calculation.

Figure D-20. Comparison of Effects on PFD and PFDAVG for Proof-test Types (Relay, Wet=On)



Appendix E PFH Calculation

E.1 Probability of dangerous failure per hour (PFH)

For High Demand applications, product PFH values must be used to determine the suitability of a product within a SIF.

For a SIF where the safety demand interval is greater than 100⁽¹⁾ times the diagnostic interval, the SIF PFH value is calculated with the following equation:

$$PFH = \Sigma \lambda_{DU}$$

With all equipment that is part of the safety system contributing to the final PFH value. As the safety demand interval approaches the diagnostic test rate, on-line diagnostics become increasingly less useful for detecting dangerous failures. In this case, dangerous detected failures are not included in the PFH calculation.

In event of the safety demand interval being less than 100⁽¹⁾ times the diagnostic interval, the SIF PFH value is calculated with the following equation:

$$PFH = \Sigma(\lambda_{DU} + \lambda_{DD})$$

Again, with all equipment that is part of the safety system contributing to the final PFH value, but in this case dangerous detected failure figures are allowed to contribute to the final PFH value.

1. The figure of 100 is used here for illustrative purposes only, and is variable depending on user experience and available knowledge of the SIF.

Appendix F Diagnostic Intervals

F.1 Diagnostic checks and intervals

All diagnostic checks complete to entirety within one hour.

Global Headquarters

Emerson Automation Solutions

6021 Innovation Blvd.

Shakopee, MN 55379, USA

 +1 800 999 9307 or +1 952 906 8888

 +1 952 949 7001

 RFQ.RMD-RCC@Emerson.com

North America Regional Office

Emerson Automation Solutions

8200 Market Blvd.

Chanhassen, MN 55317, USA

 +1 800 999 9307 or +1 952 906 8888

 +1 952 949 7001

 RMT-NA.RCCRFQ@Emerson.com

Latin America Regional Office

Emerson Automation Solutions

1300 Concord Terrace, Suite 400

Sunrise, FL 33323, USA

 +1 954 846 5030

 +1 954 846 5121

 RFQ.RMD-RCC@Emerson.com

Europe Regional Office

Emerson Automation Solutions Europe GmbH

Neuhofstrasse 19a P.O. Box 1046

CH 6340 Baar

Switzerland

 +41 (0) 41 768 6111

 +41 (0) 41 768 6300

 RFQ.RMD-RCC@Emerson.com

Asia Pacific Regional Office

Emerson Automation Solutions

1 Pandan Crescent

Singapore 128461

 +65 6777 8211

 +65 6777 0947

 Enquiries@AP.Emerson.com

Middle East and Africa Regional Office

Emerson Automation Solutions

Emerson FZE P.O. Box 17033

Jebel Ali Free Zone - South 2

Dubai, United Arab Emirates

 +971 4 8118100

 +971 4 8865465

 RFQ.RMTMEA@Emerson.com



[Linkedin.com/company/Emerson-Automation-Solutions](https://www.linkedin.com/company/Emerson-Automation-Solutions)



[Twitter.com/Rosemount_News](https://twitter.com/Rosemount_News)



[Facebook.com/Rosemount](https://www.facebook.com/Rosemount)



[Youtube.com/user/RosemountMeasurement](https://www.youtube.com/user/RosemountMeasurement)



[Google.com/+RosemountMeasurement](https://plus.google.com/+RosemountMeasurement)

Emerson Terms and Conditions of Sale are available upon request.
The Emerson logo is a trademark and service mark of Emerson Electric Co.
Rosemount is a mark of one of the Emerson family of companies.
All other marks are the property of their respective owners.
© 2018 Emerson. All rights reserved.