

Technical Data

8" BiRotor, High Capacity

Model B101	[8"]
Model B103	[8"]
Model B104	[8"]
Model B105	[8"]

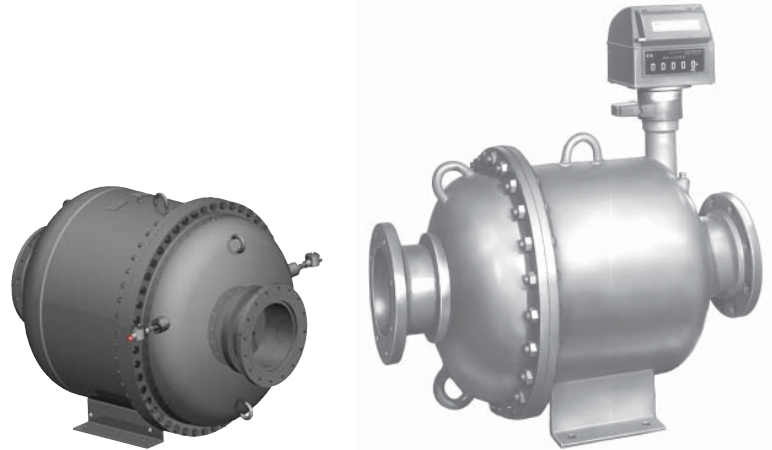

General

The BiRotor Meter is a positive displacement meter utilized in the most demanding applications requiring accuracy, long life and ruggedness.

The electronic "P" Series meter configuration features a sealed measuring chamber with one reluctance type electronic sensor. The sealed electronic sensor transmits amplified signals to local or remote instruments. A second optional sensor is available to allow dual channel pulses that are 90 degrees electrically out of phase.

Accuracy

The Mechanical BiRotor's accuracy is attained by the unique BiRotor design which features two finely balanced rotors. An adjuster, incorporated on the meter, is used to assure maximum accuracy within the meter's flow range (Mechanical Only).

Principle of Operation

The two spiral fluted rotors within the measuring unit are dynamically balanced to minimize bearing wear. (Refer to Figure 1). As the product enters the intake of the measuring unit, the two rotors divide the product into precise segments of volume momentarily and then return these segments to the outlet of the measuring unit. During this "liquid transition", the rotation of the two rotors is directly proportional to the flow rate of the liquid thruput. A gear train located outside the measuring unit chamber conveys mechanical rotation of the rotors to a mechanical or electronic register for totalization of liquid thruput. For P-Style units, a pulse verification gear located outside the measuring unit chamber conveys mechanical rotation of the rotors to the sensor and to the electronic register for totalization of liquid thruput.

Dependability

There is no metal to metal contact between the rotors and the measurement chamber. The meter is therefore extremely durable. The rotors, bearings and timing gears are the only moving parts. Maintenance requirements are the lowest in the industry. In addition, materials incorporated within the meter assembly are selected specifically for a wide range of petroleum and industrial liquid applications.

Affordability

In spite of its superior performance, Brodie can offer the Mechanical BiRotor at a very competitive price.

Electrical Classification (P-Style)

Class 1, Groups C & D, Division 1, Explosion proof; Recommended connecting cables Belden 8770, 3 Conductor Shielded, 18 gauge stranded. Maximum recommended cable length 3000 feet (914 meters). Input power: 6-28 Vdc at 20 mA, Output Signal: TTL (0-5V) or voltage dependent.

Design Features

- Extremely long service life
- Economical low maintenance
- Two simple rotors with no metal-to-metal contact are the only moving parts in the measuring chamber.
- No oscillating, reciprocating or sliding parts or cranks to wear or disturb the balanced rotary.
- Conforms with International standards of flowmeter accuracy.

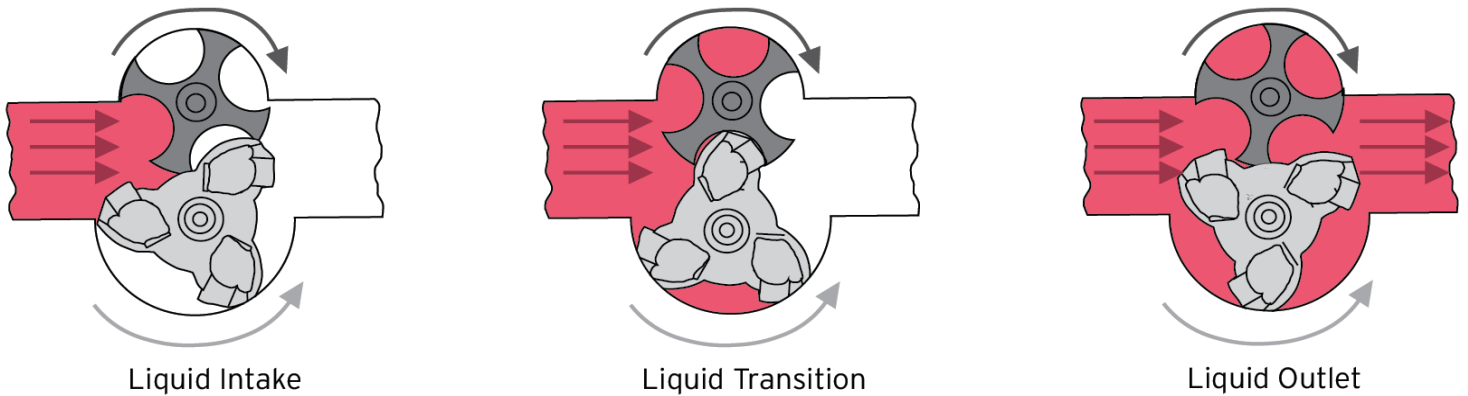

Figure 1 - BiRotor Meter Principle of Operation Diagram

Accessories

Mechanical:

- Preset Counters
- Control Valves
- Large Numerical Registers
- Pulse Transmitters
- Ticket Printers
- Strainers

P-Style:

- Electronic Register
- Dual Pickoffs for "B" Level Pulse Security
- Preamp

Ordering Information

In order to accurately process an order, such information as product to be metered, product viscosity, product temperature range, ambient temperature range, rate of flow, operating pressure, units of registration, accessories required, and optional features needed must be specified by the customer.

Materials of Construction

Housing:

Welded Steel Construction Combining Steel Castings and Drawn Steel Plate

Measuring Unit:

Rotors:

Three Lobe Rotor - Cast Iron
Four Fluted Rotor- Aluminum

Rotor Shafts:

E.T.D 150

Rotor Bearings:

Stainless Steel

Body and End Covers:

Cast Iron

Counter Base Plate:

Body:

Steel

O-Ring:

Viton (Standard)

Drive Shafts:

Stainless Steel

Drive Gears:

Stainless Steel

Ball Bearings:

Stainless Steel

Flow Ranges

Meter Models: B101, B103, B104, B105	Viscosity							
	10 cP		100 cP		300 cP		500 cP	
	Accuracy		Accuracy		Accuracy		Accuracy	
	+/- 0.15%		+/- 0.10%		+/- 0.10%		+/- 0.10%	
	Min	Max	Min	Max	Min	Max	Min	Max
BPH	357	3571	C/F	C/F	C/F	C/F	C/F	C/F
M ³ H	56.7	567	C/F	C/F	C/F	C/F	C/F	C/F

Max Working Pressure [at 100 F, 38 C]

Model	Connections	Max PSI	DIN Connections	Max Bar
B101	8" 150 lb. ANSI	285	DN 200 PN 16	16
			DN 200 PN 25	19.6
B103	8" 300 lb. ANSI	300	DN 200 PN 25	20.7
B104	8" 300 lb. ASI	740	DN 200 PN 40	40
			DN 200 PN 64	51
B105	8" 600 lb. ANSI	1480	DN 200 PN 64	64
			DN 200 PN 100	100

Temperature Range: -20F to 150F (-29C to 66C) Optional 450F

To convert pressure drop value to the actual process fluid, use the following equation:

$$\Delta PA = (cPA)^{0.25} * (SGA)^{0.75} * \Delta Pm$$

Delta PA = Pressure Drop on Actual Fluid in PSI
 cPA = Viscosity of Actual Fluid in cP
 SGA = Density of Actual Fluid in SG
 Delta Pm = Pressure Drop on Mineral Spirits
 (See Graphs below for Reference)

Pressure Drop

Test Solution: Mineral Spirits

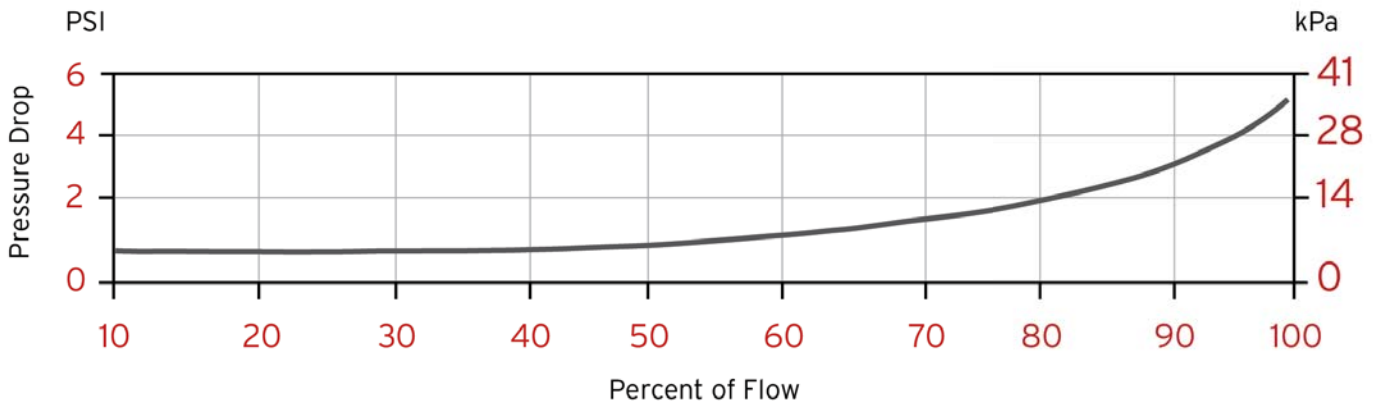

Accuracy

Capable of +/- 0.15%; Contact Factory for viscosity corrections.

Test Solution: Mineral Spirits

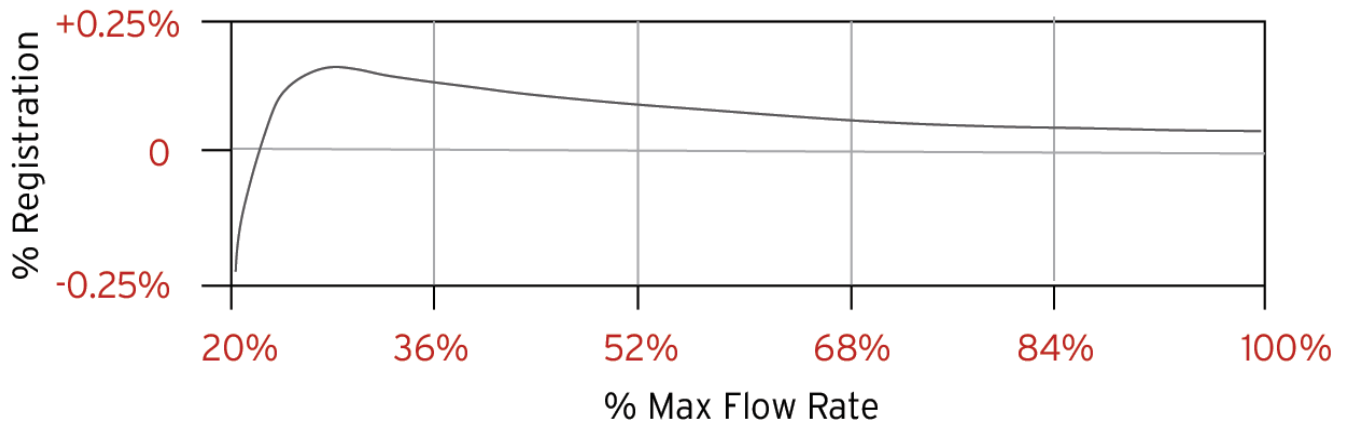

Electronic Pulses (K-Factor)	M ³ H	BBL
	3,698	588

Shipping Weights and Volume

*For Certified Dimensional Prints - Consult Factory

Model	Weight	Volume
B101	1,294 lb	24.5 ft ³
	587 kg	0.69 m ³
B103	1,368 lb	24.5 ft ³
	620 kg	0.69 m ³
B104	1,623 lb	27.6 ft ³
	736 kg	0.78 m ³
B105	2,475 lb	29.7 ft ³
	1,122 kg	0.84 m ³

NOTE:

Do NOT operate this instrument in excess of the specifications listed. Failure to heed this warning could result in serious injury and/or damage to the equipment.

Brodie International

P.O. Box 450 (30459-0450)
 19267 Highway 301 North
 Statesboro, GA 30461
 USA

Phone: +1 (912) 489-0200
 Fax: +1 (912) 489-0294