

Fisher™ HP Cryogenic Sliding-Stem Control Valves

Fisher HP cryogenic valves are high-pressure, single-port, globe-style valves featuring stainless steel construction materials and fabricated extension bonnets. The HPT-C valve is a balanced design, whereas the HPS-C valve is an unbalanced design. These cryogenic valves are designed to provide throttling or on/off control of liquids and gases at cryogenic temperatures as low as -198°C (-325°F).

When required, these rugged valves can reliably provide tight shutoff for special applications within the chemical and hydrocarbon processing industries, such as certain liquefied natural gas services.

The HPT-C valve with pressure-balanced trim allows smooth control at high pressure drops in a cryogenic environment.



X1367

FISHER HP-C VALVE WITH 657 ACTUATOR

HP Cryogenic Valves

- **HPT-C:** These valves use a balanced valve plug with ultra high molecular weight polyethylene (UHMWPE) seal ring for excellent shutoff at low temperature. Different cage/plug styles provide particular flow characteristics for highly-specialized applications. Available flow characteristics are ■ equal percentage, ■ linear, and ■ modified equal percentage.
- **HPS-C:** These valves use an unbalanced valve plug and provide excellent shutoff. Interchangeable, restricted-capacity trims and full-sized trims match a variety of process flow demands for highly-specialized applications. Available flow characteristics include ■ equal percentage, ■ linear, and ■ modified equal percentage.

Features

- **Cryogenic Spring-Loaded Seal Ring**--The seal ring and associated valve parts in the HPT-C valve is specifically designed and manufactured for excellent performance at low temperatures.
- **Stable Control**--Rugged cage guiding in the HPT-C and HPS-C valves stabilizes the valve plug at all points in its travel to reduce vibration, mechanical noise, and the need for hydraulic snubbers.
- **Cost Effective Operation and Economical Maintenance**--Increased wear resistance of hardened stainless steel trim means long-lasting service. Balanced valve plug construction in the HPT-C valve permits use of spring and diaphragm Fisher actuators.

(continued on page 3)

Specifications

Available Configurations⁽¹⁾ and Valve Sizes

HPT-C: Single-port, globe-style control valve with cage-guiding, balanced valve plug, and push-down-to-close valve plug action (figure 1)
HPS-C: Single-port, globe-style control valve with cage-guiding, unbalanced valve plug, and push-down-to-close valve plug action (figure 2)

Valve Sizes

HPS-C: ■ NPS 1 to 3 (CL900 and CL1500) ■ NPS 1 to 2 (CL2500)
HPT-C: ■ NPS 4 and 6 (CL900 and CL1500)

End Connections Styles⁽¹⁾

CL900, 1500, and 2500 raised-face and ring-type-joint flanges per ASME B16.5.
Buttweld end connection per ASME B16.25.
PN160 and PN250 flanges per EN1092-1.

Maximum Inlet Pressure⁽¹⁾

Consistent with CL900, 1500, and 2500 pressure/temperature ratings per ASME B16.34

Maximum Pressure Drop⁽¹⁾

Consistent with CL900, 1500, and 2500 pressure/temperature ratings per ASME B16.34

Trim Material

See table 1

Shutoff Classifications per ANSI/FCI 70-2 and IEC 60534-4

HPT-C and HPS-C
Metal Seat: ■ Class IV is standard ■ Class V Air Test is optional (Test will be at 50 psid air)⁽²⁾
Cryogenic Leak Test: Class C (optional)

Maximum Actuator Thrust

See table 3

Flow Characteristics

HPT-C and HPS-C
■ Equal percentage, ■ linear, ■ modified equal percentage

Flow Direction

HPT-C: Normally flow down for linear and equal percentage trims. Flow up for Whisper Trim™
HPS-C: Normally flow up

Construction Materials

Valve Body and Bonnet: CF8M
Body-bonnet Bolting: See table 2
Bonnet Bushing: S31600/filled PTFE
Spiral Wound Gasket: N06600/graphite
Packing Studs and Nuts: S31600 SST
Seal Ring (HPT-C): UHMWPE with R30003 spring
Back-Up Ring (HPT-C): S31600 (316 SST)
Retaining Ring (HPT-C): S30200 (302 SST)
Packing Follower, Lantern Ring, Packing Spring⁽³⁾ and Packing Box Ring: S31600 SST

Material Temperature Capabilities⁽¹⁾

HPT-C: -198 to 66°C (-325 to 150°F)
HPS-C: -198 to 316°C (-325 to 600°F)

Bonnet Extension Length

See figure 4 and tables 7 and 8 for standard valve dimensions

Flow Coefficients and Noise Level Prediction

See Fisher Catalog 12

Port Diameters, Valve Plug Travel, Yoke Boss, and Stem Diameters

See tables 4, 5, and 6

Packing Arrangements

Standard Material
■ Single PTFE V-ring. See figures 1 and 2
Optional Material
■ Double PTFE V-ring and
■ Graphite ribbon/filament
ENVIRO-SEAL™ Packing Systems
Packing Material: ■ PTFE V-ring and ■ Graphite ULF. See figure 3. Also see Fisher bulletin 59.1:061, ENVIRO-SEAL and HIGH-SEAL Packing System for Sliding-Stem Valves ([D101633X012](#))

Options

HPT-C: ■ Whisper Trim III and WhisperFlo™ trim for aerodynamic noise attenuation, and ■ Cavitrol™ III cages for liquid cavitation protection are available. Contact your [Emerson sales office](#) or Local Business Partner for information
HPS-C: ■ Micro-Flute and ■ Micro-Flow trim

1. Do not exceed the pressure/temperature limits in this bulletin and any applicable code limits
2. Class V shutoff cannot be performed with water. The residual trapped moisture from testing with water can cause valve and trim damages from the ice crystals formed at below freezing service temperatures.
3. A spring is used only with PTFE V-ring packing. Lantern rings replace the spring in other packing arrangements.

Features (continued)

- **Piping Economy**--Expanded end connections on NPS 4 and 6 HP valves may reduce the need for line swages, while accommodating oversized piping arrangements used to limit fluid flow velocities.
- **Cryogenic Design Features**--The stainless steel valve body and bonnet with fabricated extension are designed to meet low temperature requirements. The unique metal-to-metal seat design provides repeatable tight shutoff, reducing maintenance costs.
- **Rugged Metal Seat**--The metal-to-metal seat is designed and manufactured to provide long-lasting, reliable, tight shutoff at both ambient and cryogenic temperatures without the need for periodic lapping. This reduces the need for soft seats, even in applications with stringent shutoff requirements.
- **Fugitive Emission Protection**--The optional ENVIRO-SEAL packing systems provide an improved stem seal to help prevent the loss of valuable or hazardous process fluids, and keep emissions below the EPA limit of 100 ppm. Additionally, these live-loaded packing systems can provide long life and reliability at low temperatures to help reduce maintenance costs and downtime.
- **Thoroughly Tested**--Extensive cryogenic testing during the development of the valve design reduces the need for expensive cold testing for most applications, which results in quicker delivery and greater value.
- **Easy Maintenance**--Quick-change trim, with a clamped-in seat ring, reduces the disassembly/assembly time. The valve body can stay in the pipeline during removal of trim parts for inspection or maintenance.
- **Sour Service Capability**--For NACE applications, consult your [Emerson sales office](#) or Local Business Partner.
- **Smooth Control at High Pressure Drops**--HPT-C available on NPS 4 and 6, balanced trim provides smooth control at high pressure drops.
- **Extension Bonnet**--Standard Style III extension bonnet to meet the low temperature requirements. Optional drip plate and special designs for cold box are available for different applications.

Table 1. Fisher HPT-C and HPS-C Typical Trim Material

Valve Design	Trim Construction	Valve Plug	Valve Stem	Cage	Seat Ring
HPT-C	219	S31600 with CoCr-A seat and guide	S20910	S31600/Chrome Plate	S31600
	220	S31600 with CoCr-A seat and guide	S20910	S31600/Chrome Plate	S31600 with CoCr-A seat
HPS-C	221	S31600 with CoCr-A seat and guide	S20910	S31600/Chrome Coat	S31600
	222	S31600 with CoCr-A seat and guide	S20910	S31600/Chrome Coat	S31600 with CoCr-A seat

Table 2. Bolting Material

VALVE	SIZE	BODY-BONNET BOLTING	
		Studs	Nuts
HPT-C and HPS-C	NPS 1 to 3	SA-193-B8M Strain Hardened	SA-194-8M
	NPS 4 and 6	S20910/Chrome Coat ⁽¹⁾	S20910 ⁽¹⁾

1. Optional bolting for HPS-C, NPS 1 to 3.

Table of Contents

Features	1	Travel, Stem and Yoke Diameter	6
Specifications	2	HPS-C CL2500 Port Diameters, Valve Plug Travel, Stem and Yoke Diameter	6
Tables		HPT-C Port Diameters, Valve Plug Travel, Stem and Yoke Diameter	7
HPT-C and HPS-C Typical Trim Material	3	Dimensions	8
Bolting Materials	3		
Maximum Allowable Actuator Thrust	6		
HPS-C CL900/1500 Port Diameters, Valve Plug			

Figure 1. Fisher HPT-C Valve Assembly Detail

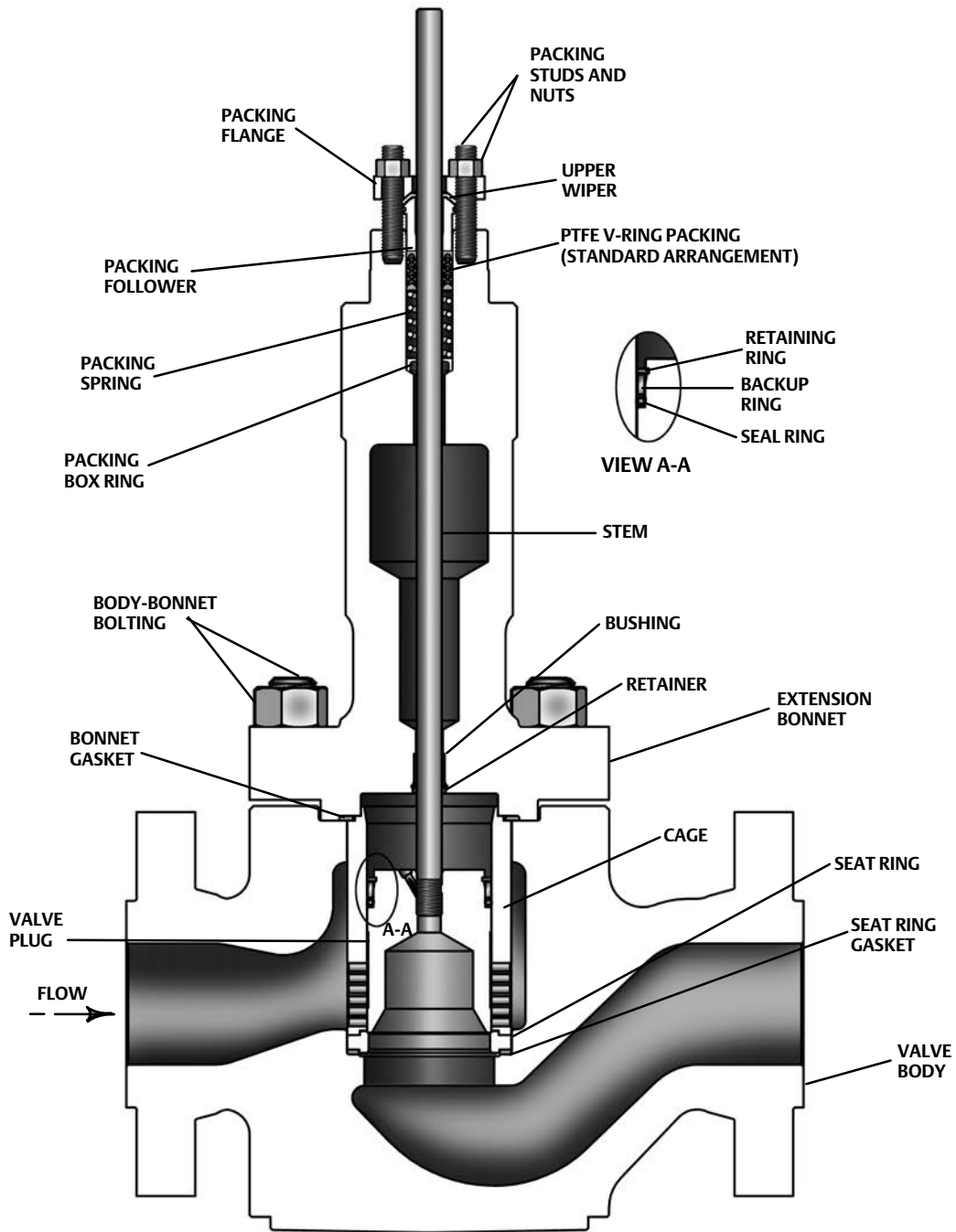
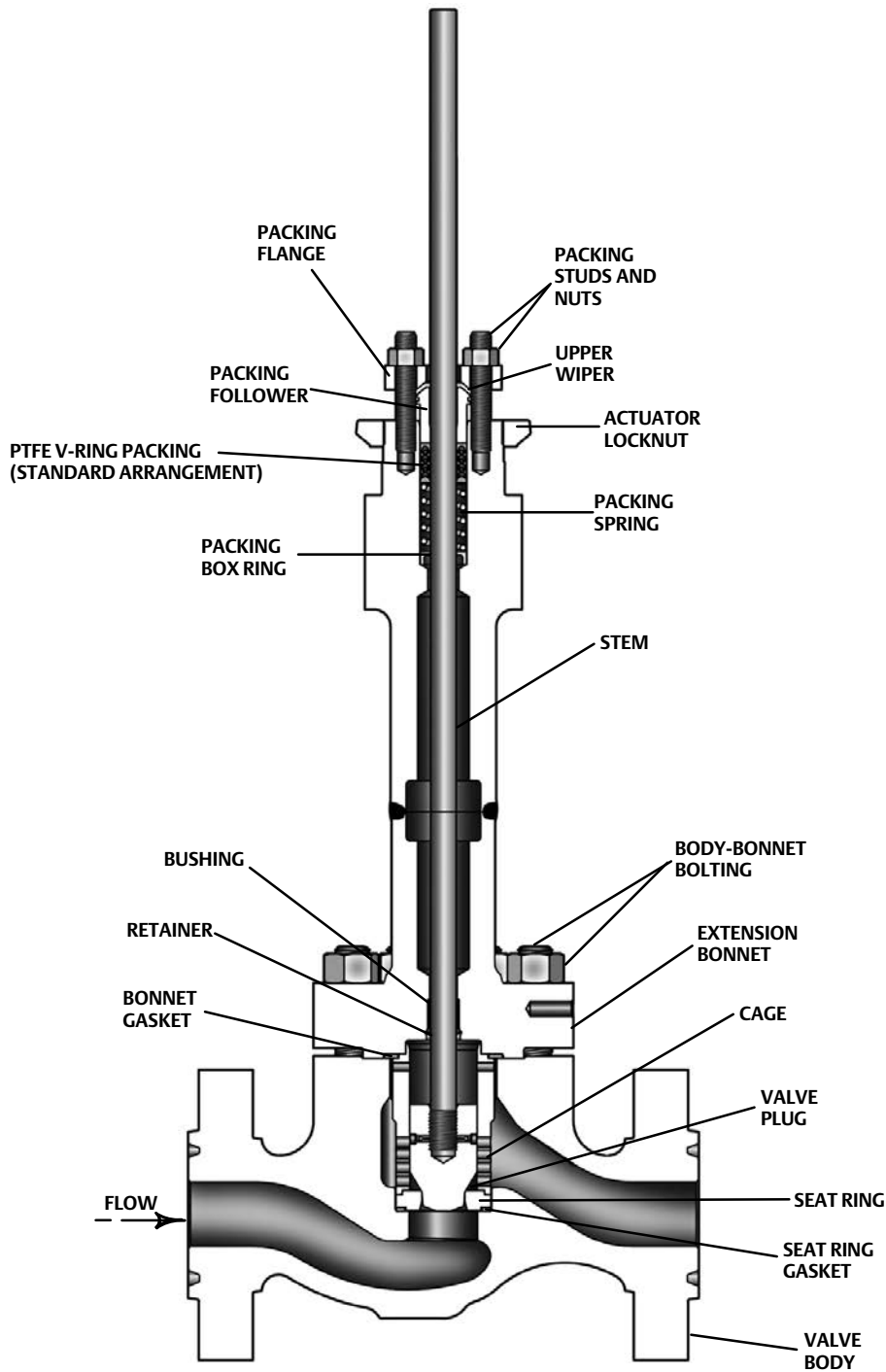

Figure 2. Fisher HPS-C Valve Assembly Detail



X1353-1

Table 3. Maximum Allowable Thrust for Style III Bonnet Extension Length

VALVE	VALVE SIZE	STEM DIAMETER		MAXIMUM ALLOWABLE STEM LOAD FOR S20910 STEM MATERIAL	
		mm	Inch	N	lb
HPT-C	4	19.1	3/4	48055	10803
		25.4	1	89956	20223
	6	25.4	1	83382	18745
		31.8	1-1/4	139185	31290
HPS-C	1	12.7	1/2	15413	3465
		19.1	3/4	45176	10156
	2	12.7	1/2	16458	3700
		19.1	3/4	46738	10507
		25.4	1	95130	21386
	3	19.1	3/4	48873	10987
25.4		1	89956	20223	

Table 4. Fisher HPS-C CL900 and 1500 Port Diameters, Valve Plug Travel, Stem and Yoke Diameters

VALVE SIZE, NPS	FLOW CHARACTERISTIC	VALVE BODY DESIGN AND PLUG STYLE	PORT DIAMETER		VALVE PLUG TRAVEL		YOKE BOSS DIAMETER		VALVE STEM DIAMETER			
			mm	Inches	mm	Inches	mm	Inches	mm	Inches		
1	Equal percentage	HPS w/Micro-Form	6.4	0.25	19	0.75	71	2-13/16	12.7	1/2		
			12.7	0.5	19	0.75	71	2-13/16	12.7	1/2		
			19.1	0.75	19	0.75	71, 90	2-13/16, 3-9/16	12.7, 19.1	1/2, 3/4		
	Modified Equal percentage	HPS w/Micro-Form	19.1	0.75	29	1.125	71, 90	2-13/16, 3-9/16	12.7, 19.1	1/2, 3/4		
25.4			1	29	1.125	71, 90	2-13/16, 3-9/16	12.7, 19.1	1/2, 3/4			
2	Equal percentage	HPS w/Micro-Form	6.4	0.25	19	0.75	71	2-13/16	12.7	1/2		
			12.7	0.5	19	0.75	71	2-13/16	12.7	1/2		
			19.1	0.75	19	0.75	71, 90	2-13/16, 3-9/16	12.7, 19.1	1/2, 3/4		
	Linear	HPS	47.6	1.875	29	1.125	71, 90, 127	2-13/16, 3-9/16, 5	12.7, 19.1, 25.4	1/2, 3/4, 1		
			47.6	1.875	38	1.5	71, 90, 127	2-13/16, 3-9/16, 5	12.7, 19.1, 25.4	1/2, 3/4, 1		
	Modified Equal percentage	HPS w/Micro-Form	25.4	1	29	1.125	71, 90, 127	2-13/16, 3-9/16, 5	12.7, 19.1, 25.4	1/2, 3/4, 1		
			31.8	1.25	29	1.125	71, 90, 127	2-13/16, 3-9/16, 5	12.7, 19.1, 25.4	1/2, 3/4, 1		
			38.1	1.5	38	1.5	71, 90, 127	2-13/16, 3-9/16, 5	12.7, 19.1, 25.4	1/2, 3/4, 1		
HPS	HPS	47.6	1.875	38	1.5	71, 90, 127	2-13/16, 3-9/16, 5	12.7, 19.1, 25.4	1/2, 3/4, 1			
		3	Equal percentage	HPS	73	2.875	38	1.5	90, 127	3-9/16, 5	19.1, 25.4	3/4, 1
							Linear	90, 127	3-9/16, 5	19.1, 25.4	3/4, 1	
Modified Equal percentage	90, 127							3-9/16, 5	19.1, 25.4	3/4, 1		

Table 5. Fisher HPS-C CL2500 Port Diameters, Valve Plug Travel, Stem and Yoke Diameters

VALVE SIZE, NPS	FLOW CHARACTERISTIC	VALVE BODY DESIGN AND PLUG STYLE	PORT DIAMETER		VALVE PLUG TRAVEL		YOKE BOSS DIAMETER		VALVE STEM DIAMETER	
			mm	Inches	mm	Inches	mm	Inches	mm	Inches
1	Equal percentage	HPS w/Micro-Form	6.4	0.25	19	0.75	71	2-13/16	12.7	1/2
			12.7	0.5	19	0.75	71	2-13/16	12.7	1/2
			19.1	0.75	19	0.75	71, 90	2-13/16, 3-9/16	12.7, 19.1	1/2, 3/4
	Modified Equal percentage	HPS w/Micro-Form	19.1	0.75	29	1.125	71, 90	2-13/16, 3-9/16	12.7, 19.1	1/2, 3/4
25.4			1	29	1.125	71, 90	2-13/16, 3-9/16	12.7, 19.1	1/2, 3/4	
2	Equal percentage	HPS w/Micro-Form	6.4	0.25	19	0.75	71	2-13/16	12.7	1/2
			12.7	0.5	19	0.75	71	2-13/16	12.7	1/2
			19.1	0.75	19	0.75	71, 90	2-13/16, 3-9/16	12.7, 19.1	1/2, 3/4
	Linear	HPS	47.6	1.875	25.4	1	71, 90, 127	2-13/16, 3-9/16, 5	12.7, 19.1, 25.4	1/2, 3/4, 1
			47.6	1.875	25.4	1	71, 90, 127	2-13/16, 3-9/16, 5	12.7, 19.1, 25.4	1/2, 3/4, 1
	Modified Equal percentage	HPS w/Micro-Form	25.4	1	29	1.125	71, 90, 127	2-13/16, 3-9/16, 5	12.7, 19.1, 25.4	1/2, 3/4, 1
			31.8	1.25	29	1.125	71, 90, 127	2-13/16, 3-9/16, 5	12.7, 19.1, 25.4	1/2, 3/4, 1
			38.1	1.5	38	1.5	71, 90, 127	2-13/16, 3-9/16, 5	12.7, 19.1, 25.4	1/2, 3/4, 1
HPS	HPS	47.6	1.875	29	1.125	71, 90, 127	2-13/16, 3-9/16, 5	12.7, 19.1, 25.4	1/2, 3/4, 1	

Table 6. Fisher HPT-C Port Diameters, Valve Plug Travel, Stem and Yoke Diameters

VALVE SIZE, NPS	FLOW CHARACTERISTIC	VALVE BODY DESIGN AND PLUG STYLE	PORT DIAMETER		VALVE PLUG TRAVEL		YOKE BOSS DIAMETER		VALVE STEM DIAMETER	
			mm	Inches	mm	Inches	mm	Inches	mm	Inches
4	Equal percentage	HPT	92.1	3.625	38	1.5	90, 127	3-9/16, 5	19.1, 25.4	3/4, 1
	Linear				51	2	90, 127	3-9/16, 5	19.1, 25.4	3/4, 1
	Modified Equal percentage						90, 127	3-9/16, 5	19.1, 25.4	3/4, 1
6	Equal percentage	HPT	136.5	5.375	64	2.5	127	5	25.4, 31.8	1, 1-1/4
	Linear				76	3	127	5	25.4, 31.8	1, 1-1/4
	Modified Equal percentage						127	5	25.4, 31.8	1, 1-1/4

Figure 3. ENVIRO-SEAL Packing Systems

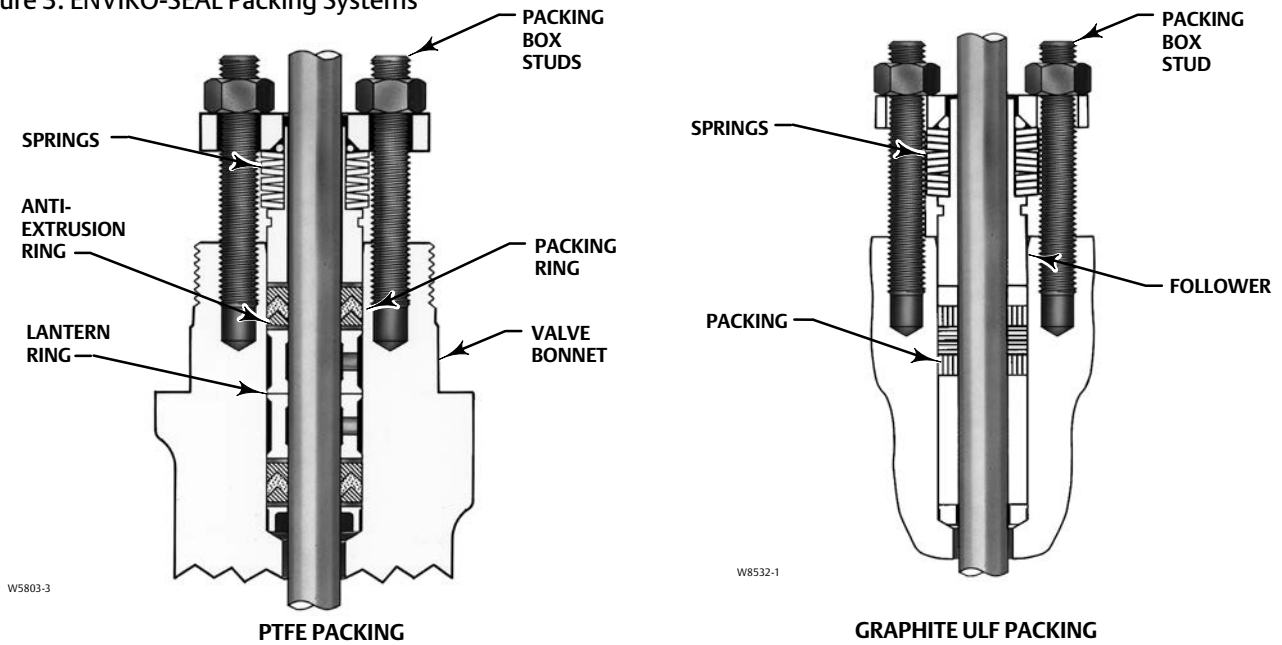
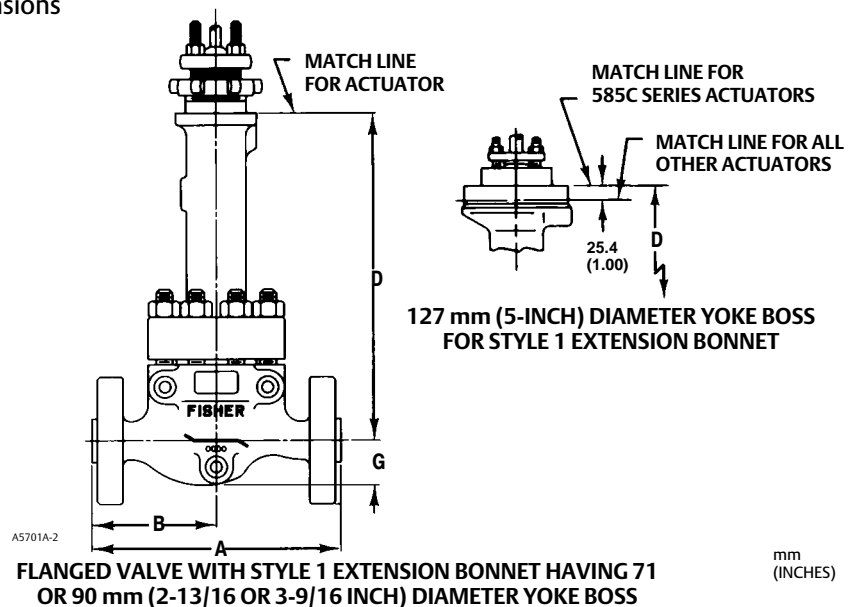

Figure 4. Valve Dimensions



mm
(INCHES)

Product Bulletin

51.2:HP Cryogenic
August 2017

HP Cryogenic Valves

D104174X012

Table 7. Fisher HPS-C CL2500 Valve Dimensions

VALVE SIZE, NPS	A		B		G	D		
	CL2500		CL2500			Yoke Boss Diameter, mm (inches)		
	RF	RTJ	RF	RTJ	CL2500	71 (2-13/16)	990 (3-9/16)	137 (5)
mm								
1	318	318	159	159	63	533	533	---
2	413	416	206	208	84	470	470	445
Inches								
1	12.5	12.5	6.25	6.25	2.47	21	21	---
2	16.25	16.38	8.12	8.19	3.31	18.53	18.53	17.5

Table 8. Fisher HPT-C and HPS-C CL900 and 1500 Valve Dimensions⁽¹⁾

VALVE SIZE, NPS	A						B						G	D		
	ASME				EN		ASME				EN			Yoke Boss Diameter, mm (inches)		
	CL900		CL1500		PN160	PN250	CL900		CL1500		PN160	PN250	CL900 and CL1500	71 (2-13/16)	990 (3-9/16)	137 (5)
	RF	RTJ	RF	RTJ			RF	RTJ	RF	RTJ						
mm																
1	292	292	292	292	269	277	146	146	146	146	134	138	52	553	553	---
2	375	378	375	378	344	360	187	189	187	189	172	180	77	553	553	445
3	442	445	460	464	442	460	221	222	230	232	192	202	121	---	553	CF
4	511	514	530	533	511	530	229	230	238	240	218	232	175	---	553	CF
6	714	718	768	775	714	768	310	311	337	340	298	316	248	---	---	402
Inches																
1	11.5	11.5	11.5	11.5	10.58	10.9	5.75	5.75	5.75	5.75	5.29	5.45	2.06	21	21	---
2	14.75	14.88	14.75	14.88	13.56	14.18	7.38	7.44	7.38	7.44	6.78	7.09	3.06	21	21	17.5
3	17.38	17.5	18.12	18.25	17.38	18.12	8.69	8.75	9.06	9.12	7.54	7.94	4.75	---	21	CF
4	20.12	20.25	20.88	21	20.12	20.88	9	9.06	9.38	9.44	10.75	9.13	6.88	---	21	CF
6	28.12	28.25	30.25	30.5	28.12	30.25	12.19	12.3	13.3	13.38	11.72	12.43	9.75	---	---	30

1. NPS 1 to 3 for HPS-C and NPS 4 to 6 for HPT-C.

Neither Emerson, Emerson Automation Solutions, nor any of their affiliated entities assumes responsibility for the selection, use or maintenance of any product. Responsibility for proper selection, use, and maintenance of any product remains solely with the purchaser and end user.

Fisher, WhisperFlo, Cavitrol, Whisper Trim, and ENVIRO-SEAL are marks owned by one of the companies in the Emerson Automation Solutions business unit of Emerson Electric Co. Emerson Automation Solutions, Emerson, and the Emerson logo are trademarks and service marks of Emerson Electric Co. All other marks are the property of their respective owners.

The contents of this publication are presented for informational purposes only, and while every effort has been made to ensure their accuracy, they are not to be construed as warranties or guarantees, express or implied, regarding the products or services described herein or their use or applicability. All sales are governed by our terms and conditions, which are available upon request. We reserve the right to modify or improve the designs or specifications of such products at any time without notice.

Emerson Automation Solutions
Marshalltown, Iowa 50158 USA
Sorocaba, 18087 Brazil
Cernay, 68700 France
Dubai, United Arab Emirates
Singapore 128461 Singapore

www.Fisher.com

