



THERMATEL® TD2

Thermal dispersion switch

FOR HYGIENIC USE

DESCRIPTION

Thermatel® TD2 switches can easily be adjusted to detect flow (gases and liquids), level or liquid-liquid interface. The TD2 is either V DC or V AC line powered and offers additionally LED indication, time delay and mA output for diagnostics and trending.

The units have both 3A and EHEDG approval for use in hygienic applications.

FEATURES

- Easy field calibration – pre-calibration from factory at request.
- Variable flow or Flow/No flow detection of gases and liquids.
- Excellent low flow sensitivity.
- Automatic temperature compensation for repeatable alarm under varying process temperatures.
- Continuous diagnostics detect sensor fault.
- Continuous monitoring of flow rate versus setpoint via LED.
- mA output provides repeatable indication of flow rate and fault detection.
- Flow can be measured over test points.
- Suited for SIL1 loops (full FMEDA report available).



APPLICATIONS

MEDIA: All types of gases and liquids.

VESSELS: Max sensor length up to 3,3 m. Can be installed at any angle vertically/horizontally.

CONDITIONS: Can be used on conductive and non conductive media, very light density to heavy viscous media (up to 10.000 cP). Can be set to ignore foam, aeration, turbulence, and cavitation.

For FLOW/LEVEL/INTERFACE applications



AGENCY APPROVALS^①

Agency	Approval
TNO	Hygienic Machinery Directive 98/37/EC annex 1, section 2.1 EN 1672 part 2, Hygienic requirements EHEDG doc. 2 (second edit. March 2000) and doc. 8 (July 1993)
Other approvals are available, consult factory for more details	

^① Refer to bulletin BE 54-110 and BE 54-105 for ATEX/FM/CSA approved units.

TECHNOLOGY

The unit utilises Magnetrol's proven thermal dispersion technology. The sensor consists of two RTD (Resistance Temperature Detector) elements. One is the reference and the second is heated to a temperature above the process temperature. The electronics detect the temperature difference between the two elements. The temperature difference is greatest in air, then decreases when cooling occurs due to a change in media. An increase in the flow rate further decreases the temperature difference.

The set point is adjusted for the switch to alarm at the desired temperature difference. Once the set point is reached, the relay will change state.

ADVANCED FEATURES

mA output

- for trending: the calibrated setpoint corresponds with a specific mA value but although not linear, it provides important process information. With increasing flow or immersed sensor, the mA signal increases.
- for diagnostics: either 3,6 mA (Low Level Fail-safe) or 22 mA (High Level Fail-safe) output, indicates for an instrument failure (sensor).

Test points

Allow the user to periodically check the setpoint and verify for set point drift. The setpoints read voltage units.

LED indication

The LED's show progressively actual flow/level versus the calibrated setpoint.

Factory calibration

TD2 can be delivered pre-calibrated at a fixed setpoint. TD2 can be delivered with a complete calibration curve, allowing the customer to field adjust the setpoint by using a voltmeter at the test points.

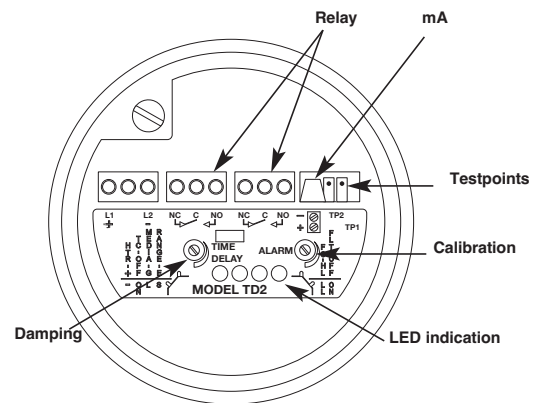

APPLICATIONS

FLOW

Thermatel® TD2 switches may be installed in a variety of flow applications as shown in the illustration below. Flow/No Flow can be detected in an input line to a primary tank, or in an output line. They may be installed for overflow detection in a pipe connected to an overflow tank or installed in a drain line for Wet/Dry indication. In addition, due to the capability to detect liquids or gases, the Thermatel® flow switch may be installed in a gas vent to detect off-gas from the primary tank.

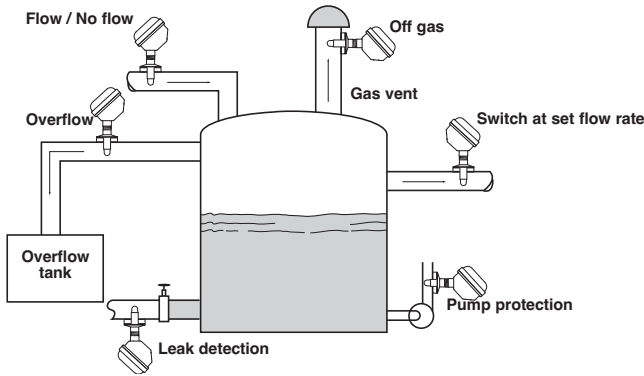

- Water for Injection (WFI)
- Filtration systems
- Separation systems
- CIP systems
- Air, CO₂, N₂ flow

LEVEL

Thermatel® TD2 switches can be installed in a variety of level applications as shown in the illustration below. High or low level alarm applications can be installed in either vertical or horizontal mountings.

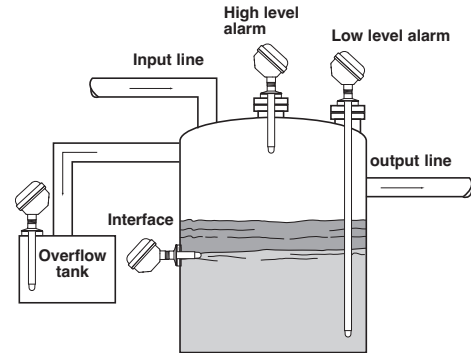

- High level
- Low level
- Interface between different media
 - Oil/water
 - Liquid/foam
- Suitable for any liquid level detection including:
 - High viscosity
 - High solids content
 - Aeration
 - Foam
- Insensitive to dielectric, specific gravity, viscosity

PUMP PROTECTION

Installed on the suction or discharge of a pump, a Thermatel® switch provides rapid indication of a low flow or no flow condition to prevent pump damage. No moving parts, excellent low flow sensitivity, and low hysteresis between alarm and reset points are all important features in this application. Enhanced temperature compensation minimizes set point drift due to varying process temperatures.

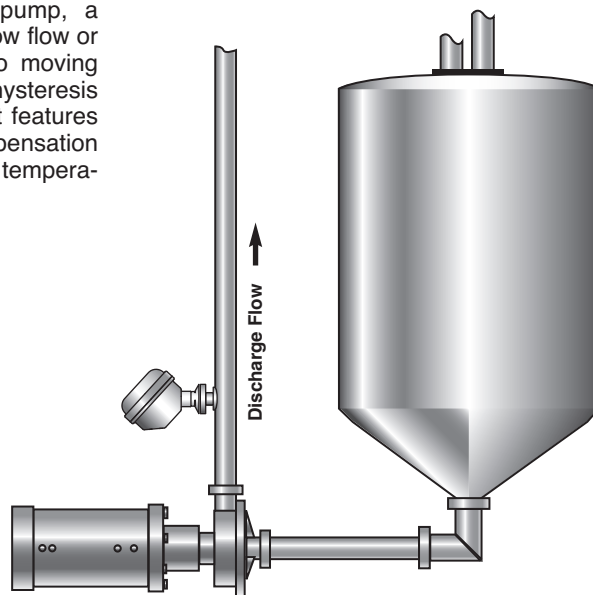

Centrifugal pump protection

SELECTION DATA

A complete measuring system consists of:

1. THERMATEL® electronics
2. THERMATEL® sensor
3. Option: Factory calibration, consult factory

1. Order code for Thermatel® electronics

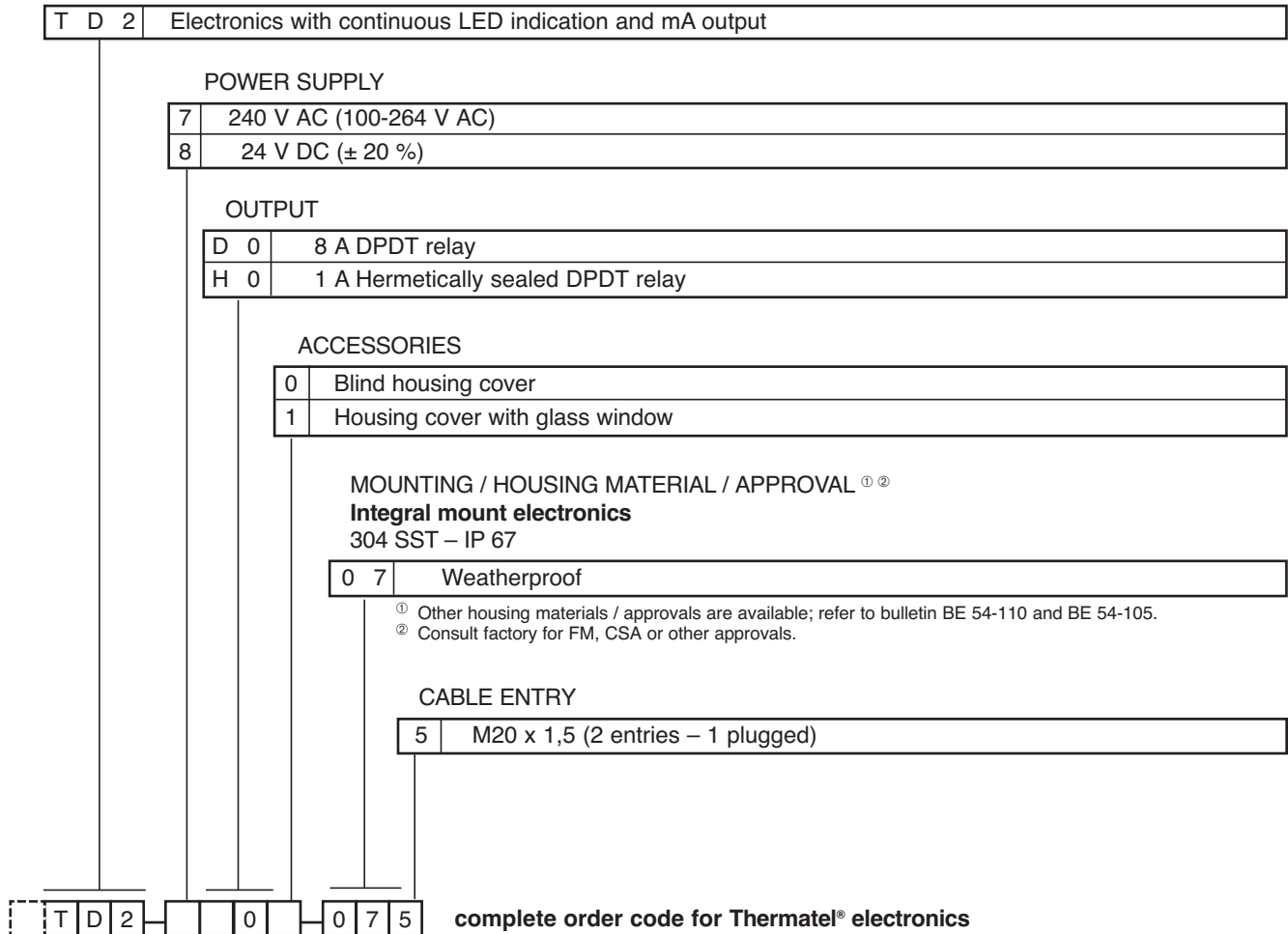

→ X = product with a specific customer requirement

2. Order code for Thermatel® sensor

T M A	Spherical tip - standard	max +120 °C (+250 °F)
T M B	Spherical tip - with heat extension	max +200 °C (+400 °F)

SENSOR MATERIAL (0,82 Mm Ra (32 Ra) surface finish)

A	316/316L (1.4401/1.4404) stainless steel
---	--

PROCESS CONNECTION – SIZE/TYPE ①

3 T 0	1 1/2" Tri-Clamp®
4 T 0	2" Tri-Clamp®
B S 0	DN 25 DIN 11851 - only available with TMA
C S 0	DN 40 DIN 11851 - only available with TMA
D S 0	DN 50 DIN 11851 - only available with TMA
V V 0	DN 65 Varivent® type N - only available with TMA

① Consult factory for other process connections (NEUMO BioControl®, G1A, ...)

INSERTION LENGTH – Specify per cm (0.39") increment

0 0 7	Minimum 7 cm (2.76")
3 3 0	Maximum 330 cm (130")

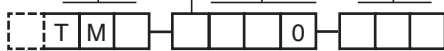

complete order code for Thermatel® sensor

→ X = product with a specific customer requirement

DIMENSIONS in mm (inches)

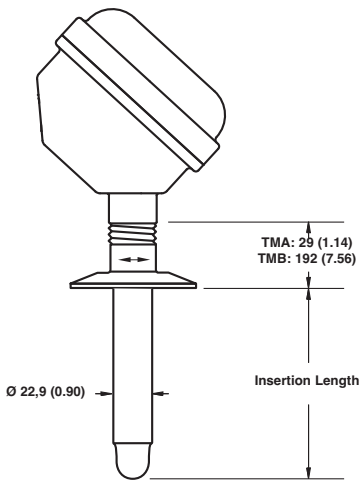
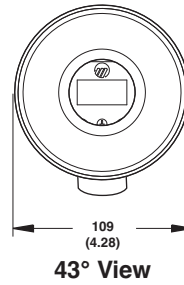
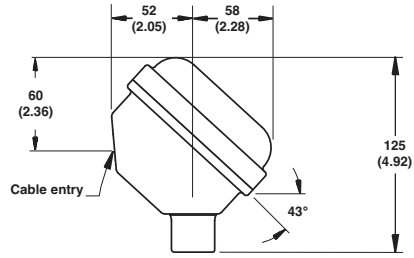

Tri-Clamp®

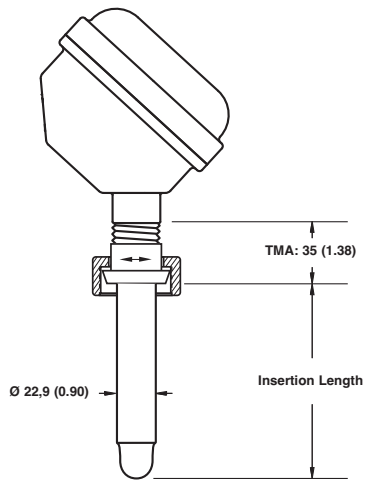

DIN 11851

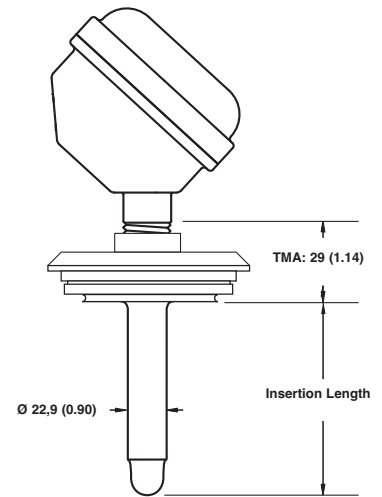

Varivent®

ELECTRONICS SPECIFICATIONS

Description		Specification
Power supply		19,2 to 28,8 V DC 100 to 264 V AC, 50-60 Hz
Power consumption		4 W @ 24 V DC or 5 W @ 264 V AC
Flow range		0,003 to 1,5 m/s (0.01 to 5.0 FPS) – water 0,03 to 150 m/s (0.1 to 500 FPS) – air
Output	Alarm	8 A DPDT relay @ 30 V DC / 250 V AC 1 A hermetically sealed DPDT relay @ 28 V DC
	Continuous	non-linear mA for trending
	Error	3,6 mA (Low Level Fail-safe) – 22 mA (High Level Fail-safe) and alarm relay
Time delay		0 to 100 s adjustable (in addition to sensor response time)
User interface		- Local switches for gain setting, function setting and High/Low Level Fail-safe - Calibration and time delay via potentiometer
Display		2 green LED's (safe condition) 1 yellow LED (alarm setpoint being approached) 1 red LED (alarm condition)
Approvals		EHEDG (per TNO) and 3A certification
SIL (Safety Integrity Level)		Functional safety to SIL1 as 1oo1 in accordance to IEC 61508 – SFF of 73 % Full FMEDA reports and declaration sheets available at request
Housing material		304 stainless steel, IP 67
Net weight		1,1 kg (2.4 lbs) - electronics only

PERFORMANCE

Description	Specification
Response time	1-10 s typical (dependant on application and set point)
Repeatability	< 1 % @ constant temperature
Ambient temperature	-40 °C to +70 °C (-40 °F to +160 °F) Storage: -50 °C to +75 °C (-58 °F to +170 °F)
Humidity	0-99, % non-condensing
Electromagnetic compatibility	Meets CE requirements (EN 61326: 1997 + A1 + A2)

SENSOR SPECIFICATIONS

Description		Specification
Material		316/316L (1.4401/1.4404)
Surface finish		0,82 µm Ra (32 Ra)
Process connection		Tri-Clamp®, DIN 11851, Varivent®
Sensor diameter		22,9 mm (0.90")
Sensor length	Max	330 cm (130")
	Min	7 cm (2.76")
Process temperature	Max	TMA: +120 °C (+250 °F); TMB: +200 °C (+400 °F)
	Min	-70 °C (-100 °F)
Max. process pressure		See info on page 8

PRESSURE/TEMPERATURE RATING

Note: max. process pressure is downrated to the design pressure of the selected process connection.

Maximum process pressure		
@ +40 °C (+100 °F)	@ +120 °C (+250 °F)	@ +200 °C (+400 °F)
41,4 bar (600 psi)	33,8 bar (490 psi)	28,6 bar (415 psi)

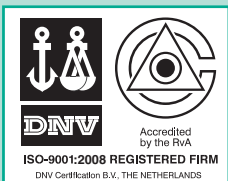
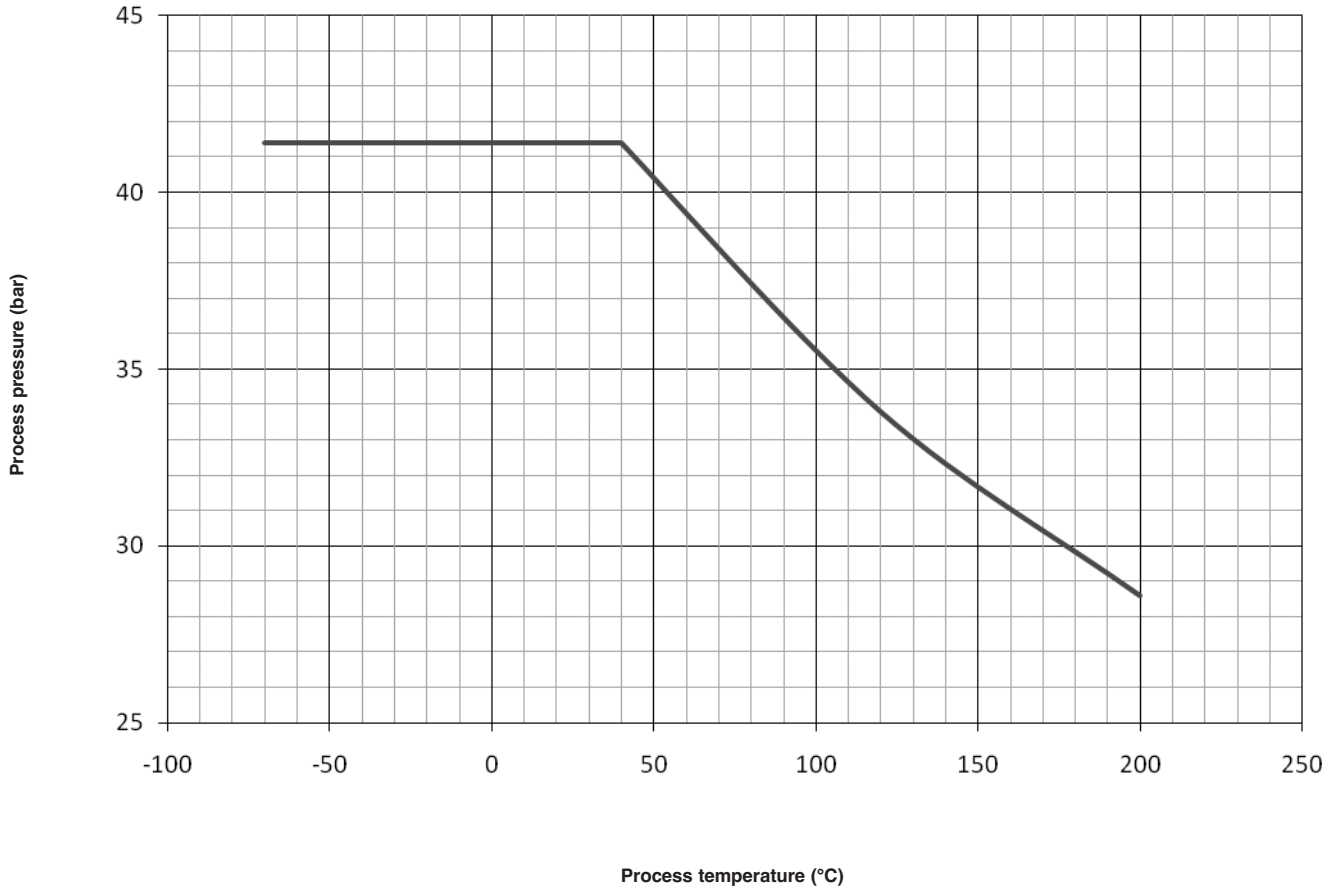

QUALITY ASSURANCE - ISO 9001:2008

THE QUALITY ASSURANCE SYSTEM IN PLACE AT MAGNETROL GUARANTEES THE HIGHEST LEVEL OF QUALITY DURING THE DESIGN, THE CONSTRUCTION AND THE SERVICE OF CONTROLS. OUR QUALITY ASSURANCE SYSTEM IS APPROVED AND CERTIFIED TO ISO 9001:2008 AND OUR TOTAL COMPANY IS COMMITTED TO PROVIDING FULL CUSTOMER SATISFACTION BOTH IN QUALITY PRODUCTS AND QUALITY SERVICE.

PRODUCT WARRANTY

ALL MAGNETROL ELECTRONIC AND ULTRASONIC LEVEL CONTROLS ARE WARRANTED FREE OF DEFECTS IN MATERIALS AND WORKMANSHIP FOR 18 MONTHS FROM THE DATE OF ORIGINAL FACTORY SHIPMENT. IF RETURNED WITHIN THE WARRANTY PERIOD; AND, UPON FACTORY INSPECTION OF THE CONTROL, THE CAUSE OF THE CLAIM IS DETERMINED TO BE COVERED UNDER THE WARRANTY; THEN, MAGNETROL INTERNATIONAL WILL REPAIR OR REPLACE THE CONTROL AT NO COST TO THE PURCHASER (OR OWNER) OTHER THAN TRANSPORTATION. MAGNETROL SHALL NOT BE LIABLE FOR MISAPPLICATION, LABOR CLAIMS, DIRECT OR CONSEQUENTIAL DAMAGE OR EXPENSE ARISING FROM THE INSTALLATION OR USE OF THE EQUIPMENT. THERE ARE NO OTHER WARRANTIES EXPRESSED OR IMPLIED, EXCEPT, SPECIAL WRITTEN WARRANTIES COVERING SOME MAGNETROL PRODUCTS.



BULLETIN N°:
EFFECTIVE:
SUPERSEDES:

BE 54-160.4
AUGUST 2017
May 2012

UNDER RESERVE OF MODIFICATIONS

BENELUX FRANCE	Heikensstraat 6, 9240 Zele, België -Belgique Tel. +32 (0)52.45.11.11 • Fax. +32 (0)52.45.09.93 • E-Mail: info@magnetrol.be
DEUTSCHLAND	Alte Ziegelei 2-4, D-51491 Overath Tel. +49 (0)2204 / 9536-0 • Fax. +49 (0)2204 / 9536-53 • E-Mail: vertrieb@magnetrol.de
INDIA	B-506, Sagar Tech Plaza, Saki Naka Junction, Andheri (E), Mumbai - 400072 Tel. +91 22 2850 7903 • Fax. +91 22 2850 7904 • E-Mail: info@magnetrolindia.com
ITALIA	Via Arese 12, I-20159 Milano Tel. +39 02 607.22.98 • Fax. +39 02 668.66.52 • E-Mail: mit.gen@magnetrol.it
RUSSIA	Business center "Farvater", Ruzovskaya Street 8B, office 400A, 190013 St. Petersburg Tel. +7 812 320 70 87 • E-Mail: info@magnetrol.ru
U.A.E.	PO Box 261454 • JAFZA LIU FZS1 – BA03, Jebel Ali Tel. +971 4 880 63 45 • Fax +971 4 880 63 46 • E-Mail: info@magnetrol.ae
UNITED KINGDOM	Unit 1 Regent Business Centre, Jubilee Road Burgess Hill West Sussex RH 15 9TL Tel. +44 (0)1444 871313 • Fax +44 (0)1444 871317 • E-Mail: sales@magnetrol.co.uk

www.magnetrol.com

OUR NEAREST REPRESENTATIVE