

In-Line Deflagration Flame Arrester

concentric design,
bidirectional

PROTEGO® FA-CN-IIA and IIB3

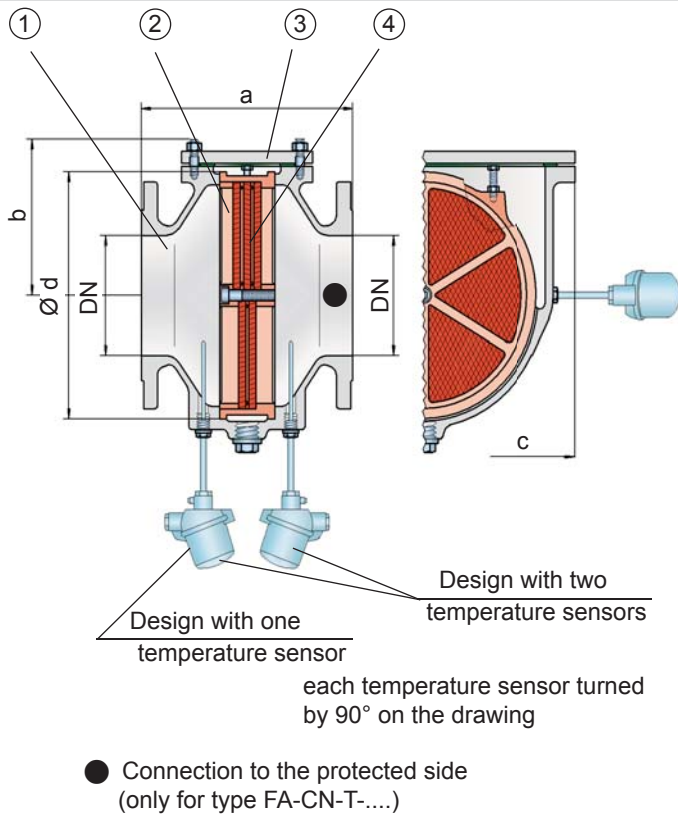

Function and Description

The PROTEGO® FA-CN in-line deflagration flame arrester is a compact design utilizing an easy access cover for easy maintainability. The PROTEGO® flame arrester unit can be removed and cleaned within moments without having to disassemble the pipe. When installing the deflagration flame arrester, make sure that the distance between potential ignition sources and the location of the installed device, does not exceed the L/D ratio (pipe length/pipe diameter), for which the device was tested. According to EN ISO 16852 this device is approved for a (L/D)_{max} ratio of 50.

The deflagration flame arrester is symmetrical and offers bidirectional flame transmission protection. The device consists of a housing (1) with an easy access cover (3) and the PROTEGO® flame arrester unit (2) in the center. The PROTEGO® flame arrester unit is modular and consists of several FLAMEFILTER® discs (3) and spacers firmly held in a FLAMEFILTER® cage. The number of FLAMEFILTER® discs and their gap size depend on the devices intended use.

Providing the operating conditions such as the temperature, pressure, explosion group and the composition of the fluid, enables PROTEGO® to select the best deflagration flame arrester for your application. This version of PROTEGO® FA-CN-IIA and IIB3 flame arrester protects against deflagrations of fuel/air mixtures of explosion groups IIA and IIB 3 (NEC D and C (MESG ≥ 0.65 mm)). PROTEGO® FA-CN devices for substances of explosion groups IIA1 and IIC (NEC group B) are shown on separate pages.

The standard design can be used up to an operating temperature of +60°C / 140°F and an absolute operating pressure up to 1.1 bar / 15.9 psi. Devices with special approval can be obtained for higher pressures (see table 3) and higher temperatures upon request.

Type-approved in accordance with the current ATEX Directive and EN ISO 16852 as well as other international standards.

Special Features and Advantages

- design available for elevated operating temperatures and pressures
- compact design with easy access cover
- easy maintenance without disassembling of the pipeline
- modular flame arrester unit enables individual FLAMEFILTER® to be replaced and cleaned
- bidirectional flame transmission proof design
- provides protection against deflagrations for group IIA and IIB3 vapours (NEC group D and C)
- lowest pressure drop results in low operating and lifecycle costs
- modular design reduces spare parts cost

Design and Specifications

There are three different designs:

Basic in-line deflagration flame arrester **FA-CN - []**

In-line deflagration flame arrester with integrated temperature sensor* as additional protection against short time burning from one side **FA-CN - [T]**

In-line deflagration flame arrester with two integrated temperature sensors* for additional protection against short-time burning from both sides **FA-CN - [TB]**

Additional special devices available upon request

*Resistance thermometer for device group II, category (1) 2 (GII cat. (1) 2)

Table 1: Dimensions

Dimensions in mm / inches

To select the nominal size (DN), use the flow capacity charts on the following pages

DN	25 / 1"	32 / 1¼"	40 / 1½"	50 / 2"	65 / 2½"	80 / 3"	100 / 4"	125 / 5"	150 / 6"	200 / 8"	250 / 10"	300 / 12"
a	200 / 7.87	200 / 7.87	210 / 8.27	215 / 8.46	235 / 9.25	240 / 9.45	265 / 10.43	305 / 12.01	310 / 12.20	300 / 11.81	320 / 12.60	350 / 13.78
b	92 / 3.62	92 / 3.62	105 / 4.13	105 / 4.13	132 / 5.2	132 / 5.2	150 / 5.91	197 / 7.75	197 / 7.75	220 / 8.66	260 / 10.24	295 / 11.61
c	175 / 6.89	175 / 6.89	200 / 7.87	200 / 7.87	260 / 10.24	260 / 10.24	308 / 12.13	415 / 16.34	415 / 16.34	446 / 17.56	520 / 20.47	600 / 23.62
d	105 / 4.13	105 / 4.13	130 / 5.12	130 / 5.12	185 / 7.28	185 / 7.28	220 / 8.66	310 / 12.20	310 / 12.20	355 / 13.98	420 / 16.54	490 / 19.29

Table 2: Selection of the explosion group

MESG	Expl. Gr. (IEC/CEN)	Gas Group (NEC)	Special approvals upon request
> 0.90 mm	IIA	D	
≥ 0.65 mm	IIB3	C	

Table 3: Selection of max. operating pressure

Expl. Gr.	DN	25 / 1"	32 / 1¼"	40 / 1½"	50 / 2"	65 / 2½"	80 / 3"	100 / 4"	125 / 5"	150 / 6"	200 / 8"	250 / 10"	300 / 12"	n
IIA	P _{max}	1.6 / 23.2	1.6 / 23.2	1.6 / 23.2	1.6 / 23.2	1.6 / 23.2	1.6 / 23.2	1.5 / 21.8	1.5 / 21.8	1.5 / 21.8	1.3 / 18.9	1.3 / 18.9	1.3 / 18.9	3
IIB3	P _{max}	1.6 / 23.2	1.6 / 23.2	1.6 / 23.2	1.6 / 23.2	1.6 / 23.2	1.6 / 23.2	1.6 / 23.2	1.6 / 23.2	1.6 / 23.2	1.6 / 23.2	1.6 / 23.2	1.6 / 23.2	3

P_{max} = maximum allowable operating pressure in bar / psi absolute, higher operating pressure upon request

n = number of FLAMEFILTER®

Table 4: Specification of max. operating temperature

≤ 60°C / 140°F	T _{maximum allowable operating temperature in °C}	higher operating temperatures upon request
-	Designation	

Table 5: Material selection

Design	A	B	Special materials upon request
Housing	Steel	Stainless Steel	
Cover	Steel	Stainless Steel	
Gasket	PTFE	PTFE	
Flame arrester unit	Stainless Steel	Stainless Steel	

Table 6: Flange connection type

EN 1092-1; Form B1	other types upon request
ASME B16.5; 150 lbs RFSF	



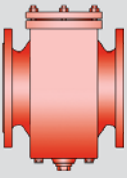

In-Line Deflagration Flame Arrester

Flow Capacity Charts

PROTEGO® FA-CN-IIA and IIB3

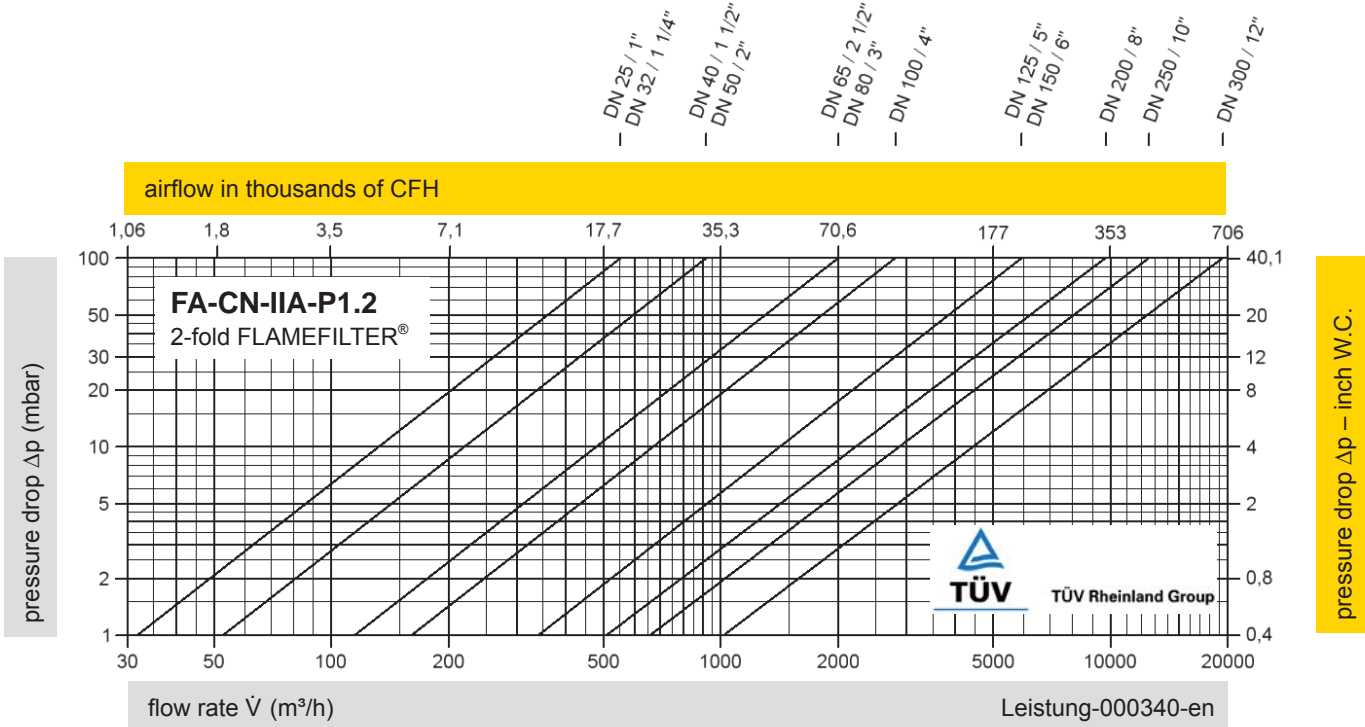

P* see table 3

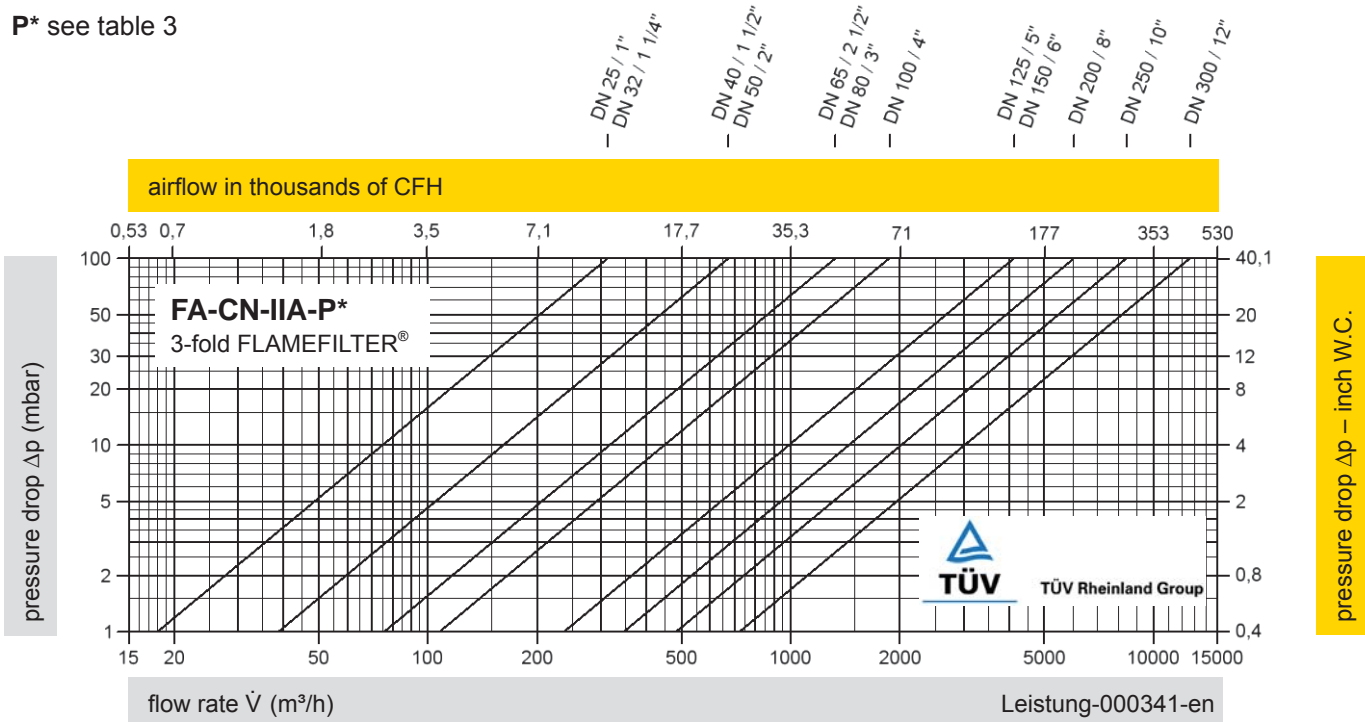

The flow capacity charts have been determined with a calibrated and TÜV certified flow capacity test rig. Volume flow \dot{V} in (m³/h) and CFH refer to the standard reference conditions of air ISO 6358 (20°C, 1bar). Conversion to other densities and temperatures refer to Vol. 1: "Technical Fundamentals".

