

## Pressure or Vacuum Relief Valve, In-Line

**PROTEGO® DZ/E**

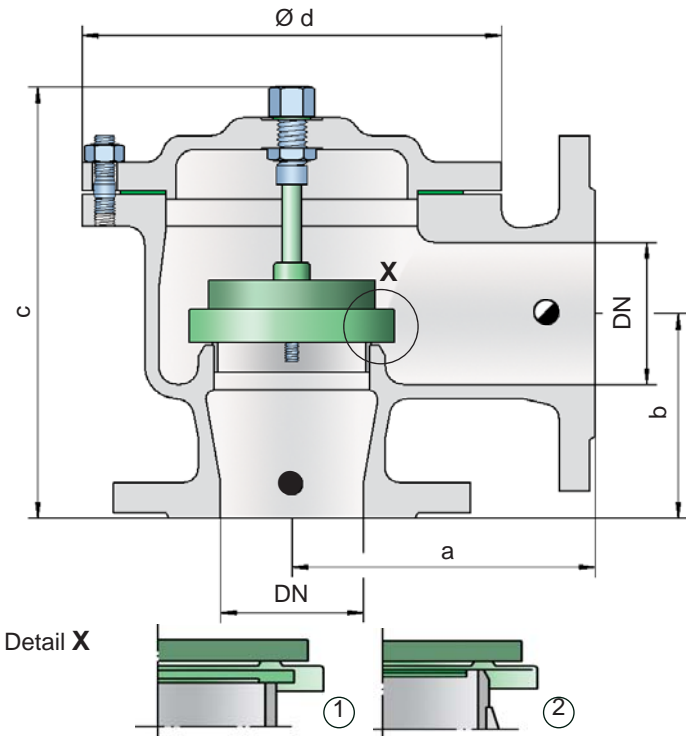

● = Tank connection for pressure relief function

● = Tank connection for vacuum relief function

Flow direction marked at the housing by →

### Pressure or vacuum settings:

DN 25 and 32	±3.5 mbar	up to ±60 mbar
DN 1" and 1½"	±1.4 inch W.C.	up to ±24 inch W.C.
DN 40	up to 300 ±2.0 mbar	up to ±60 mbar
DN 1½" up to 12"	± 0.8 inch W.C.	up to ±24 inch W.C.

For higher set pressure or vacuum refer to type DZ/E-F

### Function and Description

The PROTEGO® in-line valve DZ/E is a state-of-the-art pressure or vacuum relief valve in right angle design. Typically the valve is installed in the in- or outbreathing lines of tanks, vessels and process apparatus to protect against unallowable high or low pressure. The valve prevents emission losses almost up to the set pressure or provides protection from product entry into the system.

The device will start to open as soon as the set pressure is reached and only requires 10% overpressure to full lift. Continuous investments into research and development have allowed PROTEGO® to develop a low pressure valve which has the same opening characteristic as a high pressure safety relief valve. This "full lift type" technology allows the valve to be set just 10% below the maximum allowable working pressure or vacuum (MAWP or MAWV) of the tank and still safely vent the required mass flow. The opening characteristic is the same for pressure and vacuum relief. Due to our highly developed manufacturing technology the tank pressure is maintained up to

set pressure with a tightness that is far superior to the conventional standard. This feature is facilitated by valve seats made of high quality stainless steel and with individually lapped valve pallets (1) or with an air cushion seal (2) in conjunction with high quality FEP diaphragm. The valve pallets are also available with a PTFE seal to prevent the valve pallets from sticking when sticky products are used and to enable the use of corrosive fluids. After the excess pressure is discharged or the vacuum is compensated, the valve reseats and provides a tight seal.

The optimized fluid dynamic design of the valve body and valve pallet is a result of many years of research work, which allow a stable operation of the valve pallet and optimized performance resulting in reduction of product losses.

### Special Features and Advantages

- "full lift type" technology valve utilizes only 10% overpressure to reach full lift
- high performance seal reducing product loss below EPA's 500ppm rule preventing environmental pollution
- based on 10% technology the set pressure is close to the opening pressure which results in best possible pressure management of the system compared to conventional 40%- or 100%- technology valves
- optimized flow performance, which reduces capital cost to a minimum as smaller sized valves may be used
- can be used as pressure or vacuum relief valve
- compact right angle design saves space
- can be installed in explosion hazardous areas
- housing designed to 150 psi (PN 10)
- maintenance friendly design

### Designs and Specifications

The valve pallet is weight loaded. Higher set pressures for pressure and vacuum are achieved by using spring loaded type DZ/E-F.

Two different right angle designs are available:

In-line pressure or vacuum relief valve, standard design

**DZ/E - [ ]**

In-line pressure or vacuum relief valve with heating jacket

**DZ/E - [H]**

Additional special devices available upon request

Within piping systems the influence of backpressure has to be considered in deciding the set pressure and opening characteristics. For special design solutions (e.g. partial load operation) the valve can be supplied with standard valve pallets (with proportional opening function).

**Table 1: Dimensions**

Dimensions in mm / inches

To select the nominal size (DN), please use the flow capacity chart on the following page

DN	25 / 1"	32 / 1 ¼"	40 / 1 ½"	50 / 2"	80 / 3"	100 / 4"	150 / 6"	200 / 8"	250 / 10"	300 / 12"
a	110 / 4.33	110 / 4.33	125 / 4.92	125 / 4.92	170 / 6.69	190 / 7.48	230 / 9.06	275 / 10.83	325 / 12.80	350 / 13.78
b	75 / 2.95	75 / 2.95	90 / 3.54	90 / 3.54	115 / 4.53	120 / 4.72	160 / 6.30	225 / 8.86	275 / 10.83	300 / 11.81
c	180 / 7.09	180 / 7.09	230 / 9.06	230 / 9.06	245 / 9.65	260 / 10.24	335 / 13.19	505 / 19.88	575 / 22.64	630 / 24.80
d	150 / 5.91	150 / 5.91	170 / 6.69	170 / 6.69	235 / 9.25	280 / 11.02	335 / 13.19	420 / 16.54	505 / 19.88	565 / 22.24

Dimensions for pressure or vacuum relief valve with heating jacket upon request

**Table 2: Material selection for housing**

Design	A	B	C	
Housing	Steel	Stainless Steel	Hastelloy	Option: Housing with ECTFE-lining Special materials upon request
Heating jacket (DZ/E-H-...)	Steel	Stainless Steel	Stainless Steel	
Valve seat	Stainless Steel	Stainless Steel	Hastelloy	
Gasket	PTFE	PTFE	PTFE	
Valve pallet <b>DN 40 - 300 / 1 ½" - 12"</b>	A, C, E, F	A, C, E, F	B, D, G	
Valve pallet <b>DN 25 - 32 / 1" - 1 ¼"</b>	H, I, J	H, I, J	-	

**Table 3: Material selection for valve pallet****DN 40 - 300 / 1 ½" - 12"**

Design	A	B	C	D	E	F	G
Pressure range (mbar) (inch W.C.)	±2.0 up to ±3.5 ±0.8 up to ±1.4	±2.0 up to ±3.5 ±0.8 up to ±1.4	±3.5 up to ±14 ±1.4 up to ±5.6	±3.5 up to ±14 ±1.4 up to ±5.6	±14 up to ±60 ±5.6 up to ±24	±14 up to ±60 ±5.6 up to ±24	±14 up to ±60 ±5.6 up to ±24
Valve pallet	Aluminium	Titanium	Stainless Steel	Titanium	Stainless Steel	Stainless Steel	Hastelloy
Sealing	FEP	FEP	FEP	FEP	Metal to Metal	PTFE	Metal to Metal

**DN 25 - 32 / 1" - 1 ¼"**

Design	H	I	J	
Pressure range (mbar) (inch W.C.)	±3,5 up to ±15 ±1.4 up to ±6.0	±15 up to ±60 ±6.0 up to ±24	±15 up to ±60 ±6.0 up to ±24	Special materials upon request
Valve pallet	PTFE	Stainless Steel	Stainless Steel	For higher set pressure or vacuum refer to type DZ/E-F
Sealing	PTFE	Metal to Metal	PTFE	

**Table 4: Flange connection type**

EN 1092-1; Form B1	other types upon request
ASME B16.5; 150 lbs RFSF	



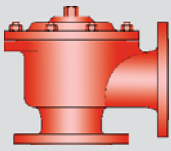

# Pressure or Vacuum Relief Valve, In-Line

## Flow Capacity Chart

### PROTEGO® DZ/E

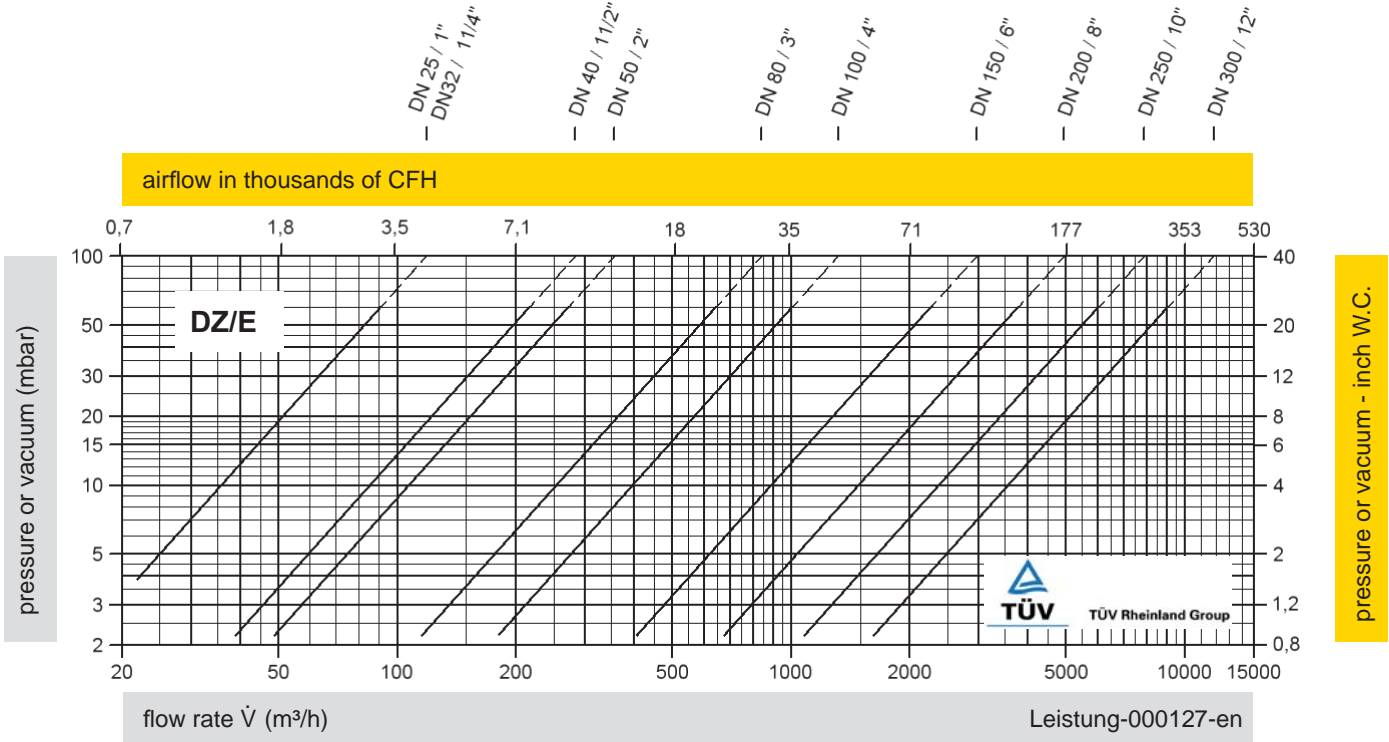

The flow capacity chart has been determined with a calibrated and TÜV certified flow capacity test rig.  
 Volume flow  $\dot{V}$  in (m<sup>3</sup>/h) and CFH refer to the standard reference conditions of air ISO 6358 (20°C, 1bar).  
 Conversion to other densities and temperatures refer to Technical Fundamentals.