

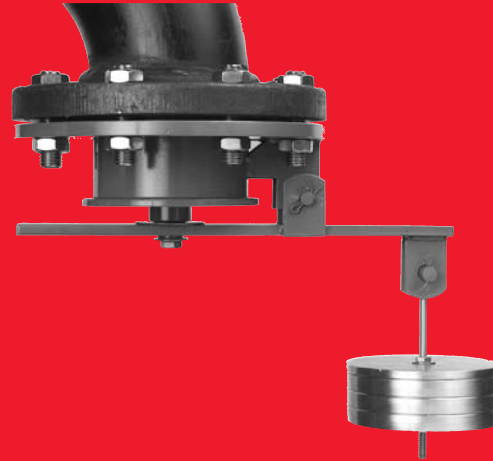

SERIES 7300D

- Mounts on storage tank overflow pipe
- Vents directly to atmosphere
- Sizes 2" (DN 50) through 12" (DN 300)
- Pressure setting achieved by weight loading
- Hinged/counterweight design allows for higher settings
- Patented, FEP Film "Air-Cushioned Seating"
- Low-Leak Pallet Design
- Available in Carbon Steel, Stainless Steel, and C276



OBJECTIVE

Protectoseal Series 7300D Overflow Valve eliminates an open overflow pipe connection into the vapor space of the tank. The Series 7300D is not a primary pressure relief device. Its function is to provide sealing of a liquid overflow pipe against gross vapor or liquid leakage until the set point of the valve is reached.

TECHNIQUE

Mount the valve to the appropriate tank flange on a vertical liquid overflow pipe using gaskets compatible with service conditions. For best performance, the vent should be mounted level so that the seating surface is no more than 1° off horizontal. Make sure the pallet assembly is free to hinge open and reseal with no interference from surrounding equipment.

The Overflow Valve will remain closed until pressure acting on the pallet assembly (caused by tank pressure and/or liquid head in the overflow pipe) exceeds the set point of the valve. The valve will hinge open and then reseal when pressure has been relieved. Liquid and vapor leakage may be encountered before the nominal set point is reached.

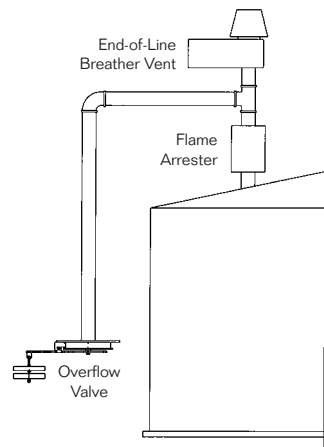

Typical Installation

Full open flow capacity and automatic reclosing of the vent as tank pressure decreases provide efficient and dependable venting capability while minimizing amount of vapor unnecessarily vented to the atmosphere.

Maintains Accurate Pressure Settings. Set points are accurate to within +/- 3% across the entire range of available pressure relief settings shown in the chart on the reverse. Set point accuracy is assured by stringent machining, assembly and test procedures.

Air-Cushioned Seating. A flat, smooth diaphragm of FEP film is supported on both sides of an annular channel to form a floating air seal with the seat.

Low-Leak Covers. Leakage on vent covers is no more than 10 SCFH at 90% of the set pressure.

Sizes Available. Available in 2" (DN 50) thru 12" (DN 300) sizes. Flanged to mate with standard flanged 150# ANSI or DIN PN 16 bolting specifications. Other drilling patterns are also available upon special request.

CONSTRUCTION

A comprehensive range of materials is offered as shown in the chart below. Other materials and features can be furnished upon request. These include C276, FRP, various diaphragm materials and metal-to-metal seating. Please consult factory for availability.

Series	Base Flange/Seat	Pallet	Pallet Diaphragm	Weight Material
7300DA	Carbon Steel	Steel	FEP Film	Steel or Lead
F7300DA	316 S.S.	316 S.S.	FEP Film	S.S. or Lead
M7300DA	C276	C276	FEP Film	C276 or Lead

Note: All materials flanged to mate with 150# ANSI or DIN PN 16 bolting specifications.

SPECIAL FEATURES

Fast Inspection, Easy Maintenance. Design and light weight of unit permit easy, convenient handling for inspection and maintenance.

Higher Pressure Settings. The hinged design of the Series 7300D allows for higher pressure settings than are available on other dead weight loaded vents of similar size.

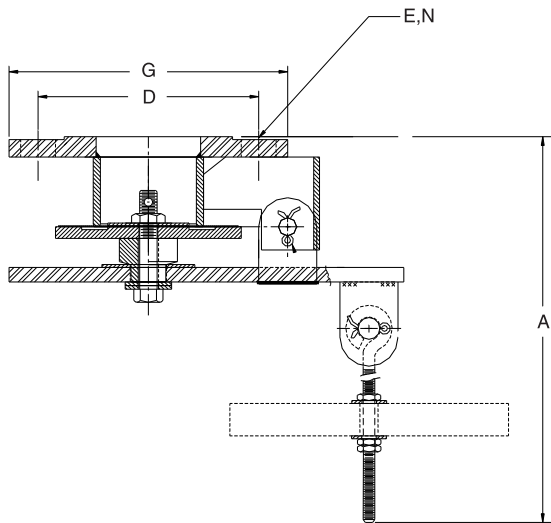

Dimensions shown are for reference only, contact Factory for certified drawings.

MATERIALS OF CONSTRUCTION

Series	Base Flange/Seat	Pallet	Pallet Diaphragm	Weight Material
7300DA	Carbon Steel	Steel	FEP Film	Steel or Lead
F7300DA	316 S.S.	316 S.S.	FEP Film	S.S. or Lead
M7300DA	C276	C276	FEP Film	C276 or Lead

Note: All materials flanged to mate with 150# ANSI or DIN PN 16 bolting specifications.

DIMENSIONS & ORDERING INFORMATION

Cat. No.	Flange Size	Ht. A	B.C. D	Dia. G	Dia. E	Holes N
7302DA	2"	9 ⁵ / ₈ "	4 ³ / ₄ "	6"	3/4"	4
7302DN	DN50	244mm	125mm	165mm	18mm	4
7303DA	3"	9 ⁵ / ₈ "	6"	7 ¹ / ₂ "	3/4"	4
7303DN	DN75	244mm	160mm	200mm	18mm	8
7304DA	4"	9 ⁵ / ₈ "	7 ¹ / ₂ "	9"	3/4"	8
7304DN	DN100	244mm	180mm	220mm	18mm	8
7306DA	6"	9 ⁵ / ₈ "	9 ¹ / ₂ "	11"	7/8"	8
7306DN	DN150	244mm	240mm	280mm	22mm	8
7308DA	8"	15 ³ / ₄ "	11 ³ / ₄ "	13 ¹ / ₂ "	7/8"	8
7308DN	DN200	400mm	295mm	340mm	22mm	12
7310DA	10"	15 ³ / ₄ "	14 ¹ / ₄ "	16"	1"	12
7310DN	DN250	400mm	355mm	405mm	26mm	12
7312DA	12"	15 ³ / ₄ "	17"	19"	1"	12
7312DN	DN300	400mm	410mm	460mm	26mm	12

MINIMUM / MAXIMUM SETTINGS

Series	Material	MINIMUM SETTINGS PRESSURE			MAXIMUM SETTINGS PRESSURE		
		oz./in. ²	in. W.C.	kPa	oz./in. ²	in. W.C.	kPa
7300DA	All Materials	1.00	1.73	0.43	24.00	41.52	10.34

Consult factory for settings outside of STANDARD range.

ADDITIONAL PRODUCTS FROM PROTECTOSEAL

Series 18540



Pipe-Away Pressure Vacuum Relief Vent for applications that require hazardous vapors be processed into manifolded piping and not released into the atmosphere.

Series 7800



Emergency Vent protects tanks against rupture or explosion resulting from excessive internal pressure caused by exposure to fires.

Series 4950



Vent Line / In-Line Parallel Plate Flame Arrester is designed for installation in open vent pipe or bleed lines from storage or processing tanks. Suitable for NEC Group D (IEC Group IIA) vapors.

Series 830



Combination Pressure / Vacuum Relief Vent & Flame Arrester provides pressure and vacuum relief as well as protection from propagation of externally introduced flames. Suitable for NEC Group D (IEC Group IIA) vapors.