



OPTIFLUX 5000 **Technical Datasheet**

Electromagnetic flowmeter in flanged version

- Exceptional long-term stability and accuracy
- For highly aggressive and abrasive fluids
- Fully vacuum-resistant with high-tech ceramics liner



The documentation is only complete when used in combination with the relevant documentation for the signal converter.

1	Product features	3
<hr/>		
1.1	Solution with high-tech ceramics	3
1.2	Options and variants	5
1.3	Measuring principle.....	6
2	Technical data	7
<hr/>		
2.1	Technical data.....	7
2.2	Dimensions and weights	13
2.3	Measuring accuracy	17
3	Installation	18
<hr/>		
3.1	Intended use	18
3.2	General notes on installation	18
3.2.1	Vibration	18
3.2.2	Magnetic field.....	18
3.3	Installation conditions	19
3.3.1	Inlet and outlet	19
3.3.2	Bends in 2 or 3 dimensions.....	19
3.3.3	T-section	19
3.3.4	Bends	20
3.3.5	Open feed or discharge.....	20
3.3.6	Control valve	21
3.3.7	Pump	21
3.3.8	Air venting and vacuum forces	21
3.3.9	Flange deviation.....	22
3.3.10	Mounting position.....	22
3.3.11	Mounting	23
3.3.12	Torques and pressures.....	23
4	Electrical connections	25
<hr/>		
4.1	Safety instructions.....	25
4.2	Grounding	25
4.3	Virtual reference for IFC 300 (C, W and F version)	26
4.4	Connection diagrams	26
5	Notes	27
<hr/>		

1.1 Solution with high-tech ceramics

The **OPTIFLUX 5000** electromagnetic flowmeter provides the optimum in accuracy, repeatability and long term stability. This is achieved with a special tube design from a high-tech ceramic zirconium oxide. Leading metrological institutes reflect this as they frequently use the **OPTIFLUX 5000** as their master meter.



Highlights

- Exceptional long-term stability and accuracy
- Unique flow tube
- Fused in-place Cermet electrodes
- For highly aggressive and abrasive fluids
- Fully vacuum-resistant
- High-tech ceramics liner
- Insensitive against temperature shocks

Industries

- Chemical
- Paper & pulp
- Water & wastewater
- Minerals & mining
- Food & beverage
- Machinery

Applications

- Master transfer meter
- Precise volumetric dosing of additives
- Chemical injection
- For acids, alkaline, abrasive slurries and many other aggressive media

1.2 Options and variants



The **OPTIFLUX 5000** in flanged version is available in a diameter range of DN15 up to DN300.

The flow sensor is offered in a large range of pressure ratings and is configurable with the IFC 100 and the IFC 300 signal converter.

The OPTIFLUX 5000 can be ordered in stainless steel version and is also optionally suitable in hazardous areas.

The installation of the OPTIFLUX 5000 can be further eased by choosing for the virtual reference option. Grounding rings can then be omitted. This can only be combined with the IFC 300 signal converter.

1.3 Measuring principle

An electrically conductive fluid flows inside an electrically insulated pipe through a magnetic field. This magnetic field is generated by a current, flowing through a pair of field coils.

Inside of the fluid, a voltage U is generated:

$$U = v * k * B * D$$

in which:

v = mean flow velocity

k = factor correcting for geometry

B = magnetic field strength

D = inner diameter of flowmeter

The signal voltage U is picked off by electrodes and is proportional to the mean flow velocity v and thus the flow rate Q . A signal converter is used to amplify the signal voltage, filter it and convert it into signals for totalizing, recording and output processing.

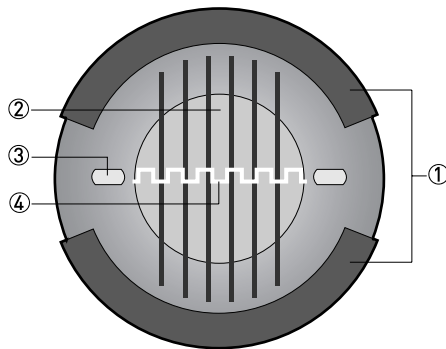

Figure 1-1: Measuring principle

- ① Field coils
- ② Magnetic field
- ③ Electrodes
- ④ Induced voltage (proportional to flow velocity)

2.1 Technical data

- *The following data is provided for general applications. If you require data that is more relevant to your specific application, please contact us or your local sales office.*
- *Additional information (certificates, special tools, software,...) and complete product documentation can be downloaded free of charge from the website (Downloadcenter).*

Measuring system

Measuring principle	Faraday's law of induction
Application range	Electrically conductive fluids
Measured value	
Primary measured value	Flow velocity
Secondary measured value	Volume flow, mass flow, electrical conductivity, coil temperature

Design

Features	Flanged version with optimized flow tube.
Modular construction	The measurement system consists of a flow sensor and a signal converter. It is available as compact and as separate version. More information about the signal converter can be found in the relevant documentation.
Compact version	With IFC 100 converter: OPTIFLUX 5100 C
	With IFC 300 converter: OPTIFLUX 5300 C
Remote version	In wall (W) mount version with IFC 100 converter: OPTIFLUX 5100 W
	In field (F), wall (W) or rack (R) mount version with IFC 300 converter: OPTIFLUX 5300 F, W or R
Nominal diameter	DN15...300 / ½...12"

Measuring accuracy

Reference conditions	Medium: water
	Temperature: +10...30°C / +50...+86°F
	Inlet section: 10 DN
	Operating pressure: 1 bar / 14.5 psig
	Electrical conductivity: $\geq 300 \mu\text{S/cm}$
Maximum measuring error	IFC 100: down to 0.3% of the measured value $\pm 1 \text{ mm/s}$
	IFC 300: down to 0.15% of the measured value $\pm 1 \text{ mm/s}$
	The maximum measuring error depends on the installation conditions.
	For detailed information refer to <i>Measuring accuracy</i> on page 17.
Repeatability	$\pm 0.1\%$ of MV, minimum 1 mm/s
Long term stability	$\pm 0.1\%$ of MV
Special calibration	On request

Operating conditions

Temperature	
Process temperature	Compact version: -40...+140°C / -40...+284°F
	Remote version: -40...+180°C / -40...+356°F
	For Ex versions different temperatures are valid. Please check the relevant Ex documentation for details.
Maximum temperature change (shock)	DN2.5...25: < 3 K/s
Ambient temperature	-40...+65°C / -40...+149°F
	For Ex versions different temperatures are valid. Please check the relevant Ex documentation for details.
Protect electronics against self-heating at ambient temperatures above +55°C / +131°F.	
Storage temperature	-50...+70°C / -58...+158°F
Measurement range	-12...+12 m/s / -40...+40 ft/s
Pressure	
Ambient	Atmospheric
Nominal flange pressure	Standard:
EN 1092-1	DN200...300: PN10
	DN100...150: PN16
	DN15...80: PN40
ASME B16.5	Standard:
	1...12": 150 lb
	½": 300 lb
	Option:
	1", 2", 3": 300 lb
Vacuum load	0 mbar / 0 psi
Pressure ranges for secondary containment	Pressure resistant up to 40 bar / 580 psi
	Burst pressure up to approx. 160 bar / 2320 psi
Chemical properties	
Physical condition	Conductive liquids

Electrical conductivity	Non water:
	DN25...300: $\geq 1 \mu\text{S/cm}$
	DN15: $\geq 5 \mu\text{S/cm}$
	Demineralised cold water:
	DN15...300: $\geq 20 \mu\text{S/cm}$
Permissible gas content (volume)	$\leq 5\%$
Permissible solid content (volume)	IFC 100: $\leq 10\%$
	IFC 300: $\leq 70\%$

Installation conditions

Installation	Assure that the flow sensor is always fully filled.
	For detailed information refer to <i>Installation</i> on page 18.
Flow direction	Forward and reverse.
	Arrow on flow sensor indicates positive flow direction.

Inlet run	≥ 5 DN (without disturbing flow, after a single 90° bend)
	≥ 10 DN (after a double bend = 2x 90°)
Outlet run	≥ 2 DN
Dimensions and weights	For detailed information refer to <i>Dimensions and weights</i> on page 13.

Materials

Sensor housing	DN15...100: stainless steel AISI 316 (1.4408)
	DN150...300: sheet steel (carbon steel)
Measuring tube	ceramic
Connection box (only remote versions)	Standard: polyurethane coated die-cast aluminium
	Option: stainless steel
Grounding rings	Standard:
	Not included
	Option: Virtual reference (only with IFC 300 converter)
Gaskets	PTFE, white
	Option: filled PTFE, blue
Measuring electrodes	Standard:
	Cermet

Process connections

EN 1092-1	DN200...300: PN10
	DN100..150: PN16
	DN15...80: PN40
ASME	Standard:
	1...12": 150 lb
	½": 300 lb
	Option:
	1", 2", 3": 300 lb

Electrical connections

For full detail; see the relevant documentation of the signal converter	
Signal cable for remote systems only.	
Type A (DS)	In combination with the IFC 050, IFC 100 and IFC 300 signal converter
	Standard cable, double shielded. Max. length: 600 m / 1950 ft (dep. on electrical conductivity and measuring sensor).
Type B (BTS)	Only in combination with the IFC 300 signal converter
	Optional cable, triple shielded. Max. length: 600 m / 1950 ft (dep. on electrical conductivity and measuring sensor).
I/O	For full details of I/O options, including data streams and protocols, see technical datasheet of the relevant signal converter.

Approvals and certifications

CE Sign	
This device fulfills the statutory requirements of the EU directives. The manufacturer certifies successful testing of the product by applying the CE mark.	
	For full information of the EU directives & standards and the approved certifications, please refer to the CE declaration or the manufacturer website.
Hazardous areas	
ATEX	Please check the relevant Ex documentation for details.
	In combination with IFC 100converter: II 2 GD
	In combination with IFC 300converter: II 2 GD or II 2 (1) GD
	Remote version: II 2 GD
	Consult IFC 300 manual for EEx i and non-EEx i I/O modules
FM	Only for diameters DN15...100 In combination with IFC 300 C or F converter
	Class I, Div. 2, groups A, B, C and D
	Class II, Div. 2, groups F and G
	Class III, Div. 2
CSA	Only for diameters DN15...100 In combination with IFC 300C or F converter
	Class I, Div. 2, groups A, B, C and D
	Class II, Div. 2, groups F and G
IEC-Ex	pending
NEPSI	OPTIFLUX 5000 F: GYJ101206
	Ex me ia IIC T6...T3
	OPTIFLUX 5300 C: GYJ101207
	Ex de ia IIC T6...T3
Other approvals and standards	
Custody transfer	Standard: without verification
	Only in combination with IFC 300 converter.
	Option: MI-001, MI-005 type examination certificate
Protection category acc. to IEC 529 / EN 60529	Standard: IP 66/67 (NEMA 4/4X/6)
	Option: IP 68 (NEMA 6P)
Hygiene	FDA approved materials.
Shock test	IEC 68-2-27
	30 g for 18 ms
Vibration test	IEC 68-2-64
	f = 20 - 2000 Hz, rms = 4.5 g, t = 30 min.

2.2 Dimensions and weights

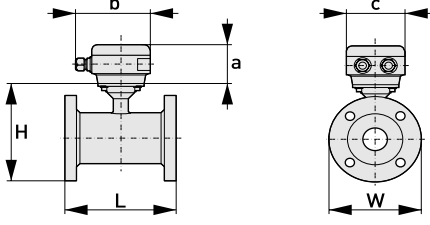
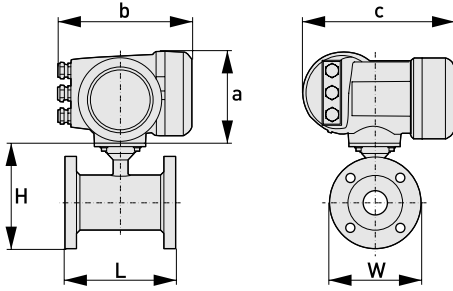
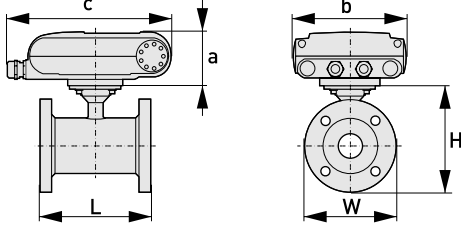
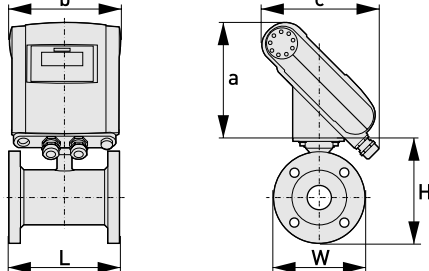
<p>Remote version</p>		<p>a = 88 mm / 3.5" b = 139 mm / 5.5" ① c = 106 mm / 4.2" Total height = H + a</p>
<p>Compact version with IFC 300</p>		<p>a = 155 mm / 6.1" b = 230 mm / 9.1" ① c = 260 mm / 10.2" Total height = H + a</p>
<p>Compact version with IFC 100 (0°)</p>		<p>a = 82 mm / 3.2" b = 161 mm / 6.3" c = 257 mm / 10.1" ① Total height = H + a</p>
<p>Compact version with IFC 100 (45°)</p>		<p>a = 186 mm / 7.3" b = 161 mm / 6.3" c = 184 mm / 7.3" ① Total height = H + a</p>

① The value may vary depending on the used cable glands.

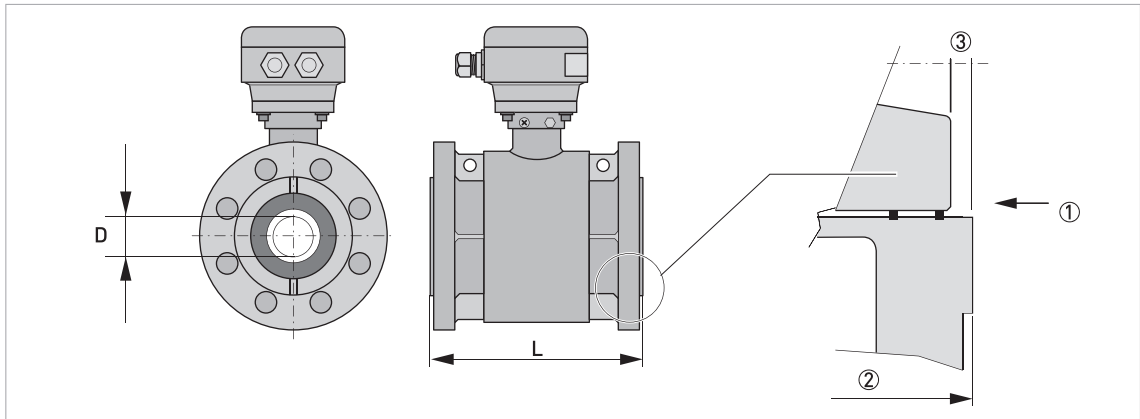

Figure 2-1: Construction details

- ① Detail ceramics / flange / gaskets, see options in following illustration
- ② Length tolerances (see table on following pages)
- ③ Gasket area

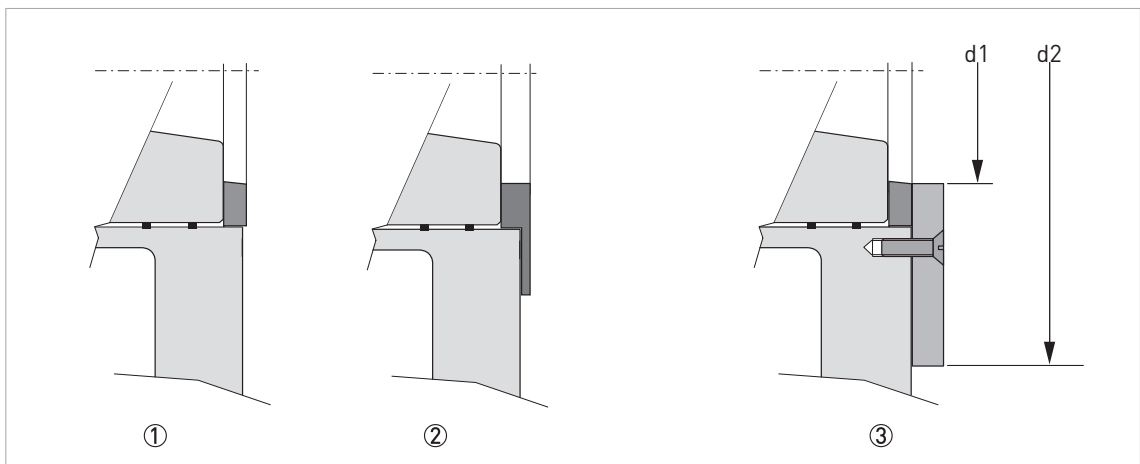

Figure 2-2: Details of gasket options

- ① PTFE (white) sealing ring
- ② Filled (blue) PTFE sealing ring
- ③ DN150...300 ; optional spacer ring with gasket

- *All data given in the following tables are based on standard versions of the flow sensor only.*
- *Especially for smaller nominal sizes of the flow sensor, the signal converter can be bigger than the flow sensor.*
- *Note that for other pressure ratings than mentioned, the dimensions may be different.*
- *For full information on signal converter dimensions see relevant documentation.*

EN 1092-1

Size	Dimensions [mm]							Approx. weight [kg]
DN	L + *	tolerance	H	W	D	Ød1	Ød2	
15	150	A	127	95	12	-	-	3
25	150	A	143	115	20	-	-	4
40	150	A	168	150	30	-	-	6
50	200	A	184	165	40	-	-	9
80	200	A	217	200	60	-	-	15
100	250	A	242	220	80	-	-	21
150	250	B	355	283	150	150	215	37
200	300	B	396	342	200	198	270	53
250	350	B	458	395	250	250	322	87
300	450	B	493	445	300	300	375	145

*L + **

- Add approximately 2 x 7.5 mm to L when using spacer rings (option for DN150...300)
- Add approximately 2 x 1.45 mm to L when using filled blue PTFE gaskets (optional)

Tolerances A & B

- A = +0.8 / -0.4 mm (+0.031 / -0.016 inches)
- B = +0.5 / -1.0 mm (+0.02 / -0.04 inches)

ASME B 16.5 150 lb

Size	Dimensions [inches]							Approx. weight [lb]
inch	L + *	tolerance	H	W	D	Ød1	Ød2	
1"	5.91	A	5.47	4.25	0.79	-	-	8.8
1½"	5.91	A	6.18	5	1.18	-	-	13.2
2"	7.87	A	6.89	6	1.57	-	-	19.8
3"	7.87	A	8.39	7.5	2.36	-	-	33.1
4"	9.84	A	9.65	9	3.15	-	-	46.3
6"	9.84	B	13.98	11	5.91	6.06	8.46	81.6
8"	11.81	B	15.59	13.5	7.80	7.99	10.63	116.8
10"	13.78	B	18.03	16	9.84	10.08	12.68	191.8
12"	17.72	B	19.41	19	11.81	12.05	14.76	366

ASME B 16.5 300 lb

Size	Dimensions [inches]							Approx. weight [lb]
inch	L + *	tolerance	H	W	D	Ød1	Ød2	
½"	5.91	A	5.0	3.74	0.47	-	-	6.8
1"	5.91	A	5.91	4.92	0.79	-	-	8.8
2"	7.87	A	7.20	6.50	1.57	-	-	22.9
3"	7.87	A	8.86	8.27	2.36	-	-	40.6
1½": not possible because of ASTM-NUT								

*L + **

- Add approximately 2 x 0.3 " to L when using spacer rings (option for 6"...12")
- Add approximately 2 x 0.055 " to L when using filled blue PTFE gaskets (optional)

Tolerances A & B

- A = +0.8 / -0.4 mm (+0.031 / -0.016 inches)
- B = +0.5 / -1.0 mm (+0.02 / -0.04 inches)

- Pressures at 20°C / 68°F.
- For higher temperatures, the pressure and temperature ratings are as per ASME B16.5.

2.3 Measuring accuracy

Each flowmeter is standard wet calibrated under reference conditions by direct volume comparison before leaving the factory. The performance of the flowmeter is defined and documented in an individual calibration certificate.

Reference conditions

- Medium: water
- Temperature: +10...30°C / +50...86°F
- Operating pressure: 1 bar / 14.5 psi
- Inlet section: ≥ 5 DN
- Electrical conductivity: $\geq 300 \mu\text{S/cm}$

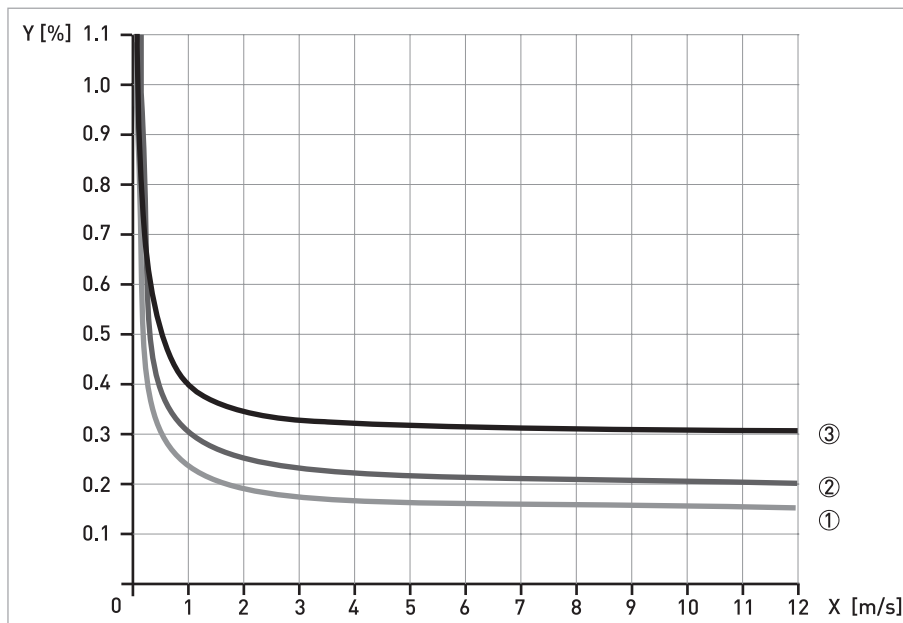

Y [m/s]: flow velocity

Y [%]: deviation from the actual measured value (MV)

Compact with IFC 300	Accuracy	Curve
DN15...100 / ½...4"	$\pm 0.15\%$ of MV + 1 mm/s	①
DN150...300 / 6...12"	$\pm 0.2\%$ of MV + 1 mm/s	②

Compact with IFC 100	Accuracy	Curve
DN15...300 / ½...12"	$\pm 0.3\%$ of MV + 1 mm/s	③

3.1 Intended use

Responsibility for the use of the measuring devices with regard to suitability, intended use and corrosion resistance of the used materials against the measured fluid lies solely with the operator.

The manufacturer is not liable for any damage resulting from improper use or use for other than the intended purpose.

The **OPTIFLUX 5000** flowmeter measures the volumetric flow rate of electrically conductive liquids, acids, alkaline solutions, pastes and slurries, also with very high solid contents.

3.2 General notes on installation

Inspect the packaging carefully for damages or signs of rough handling. Report damage to the carrier and to the local office of the manufacturer.

Do a check of the packing list to make sure that you have all the elements given in the order.

Look at the device nameplate to ensure that the device is delivered according to your order. Check for the correct supply voltage printed on the nameplate.

3.2.1 Vibration

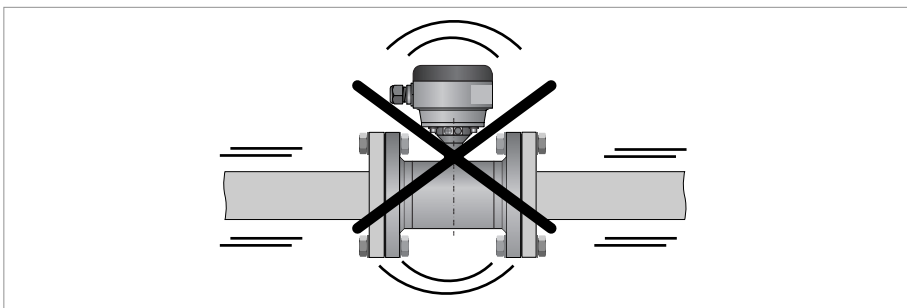

Figure 3-1: Avoid vibrations

3.2.2 Magnetic field

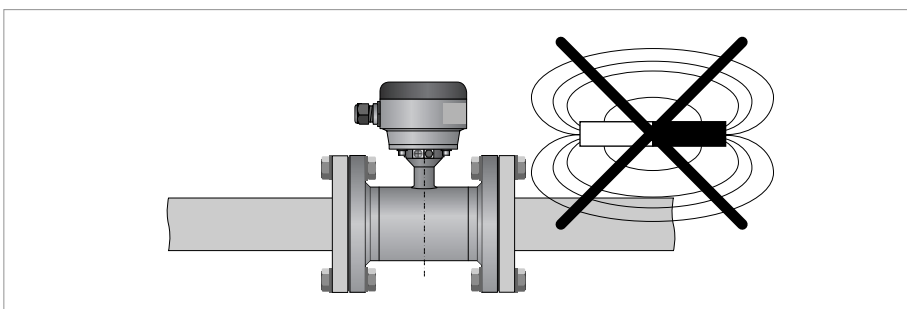

Figure 3-2: Avoid magnetic fields

3.3 Installation conditions

3.3.1 Inlet and outlet

Use straight inlet and outlet pipe sections to prevent flow distortion or swirl, caused by bends and T- sections.

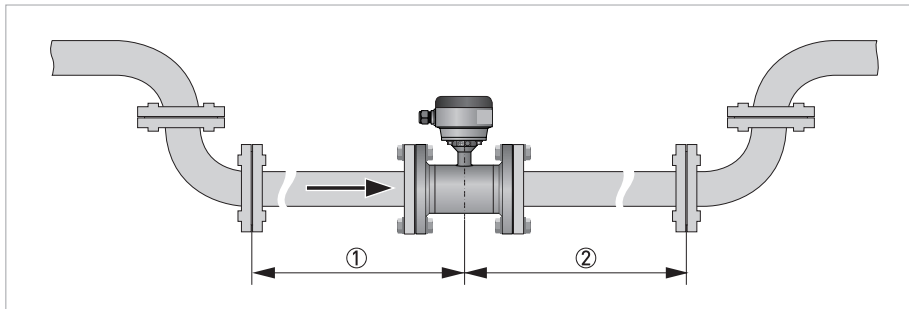

Figure 3-3: Recommended inlet and outlet section

- ① Refer to chapter "Bends in 2 or 3 dimensions"
- ② $\geq 2 \text{ DN}$

3.3.2 Bends in 2 or 3 dimensions

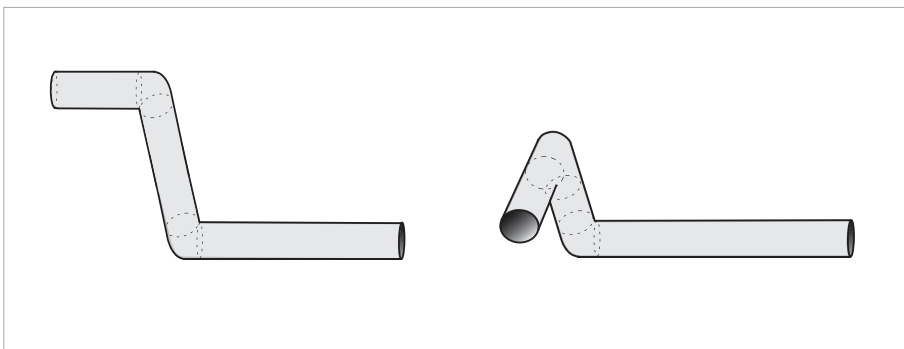

Figure 3-4: Inlet when using 2 and/or 3 dimensional bends in front of the flowmeter
Inlet length: using bends in 2 dimensions: $\geq 5 \text{ DN}$; when having bends in 3 dimensions: $\geq 10 \text{ DN}$

3.3.3 T-section

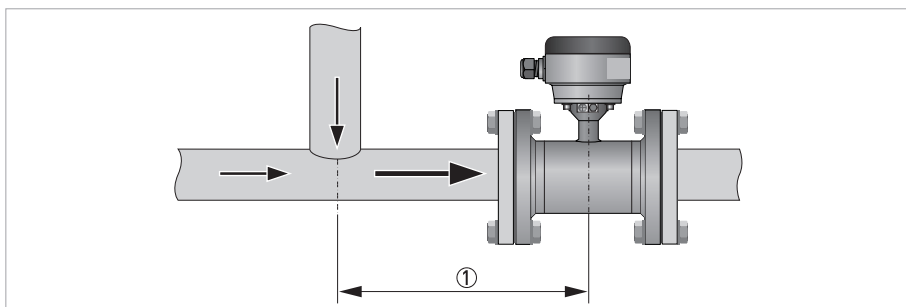

Figure 3-5: Distance behind a T-section

- ① $\geq 10 \text{ DN}$

3.3.4 Bends

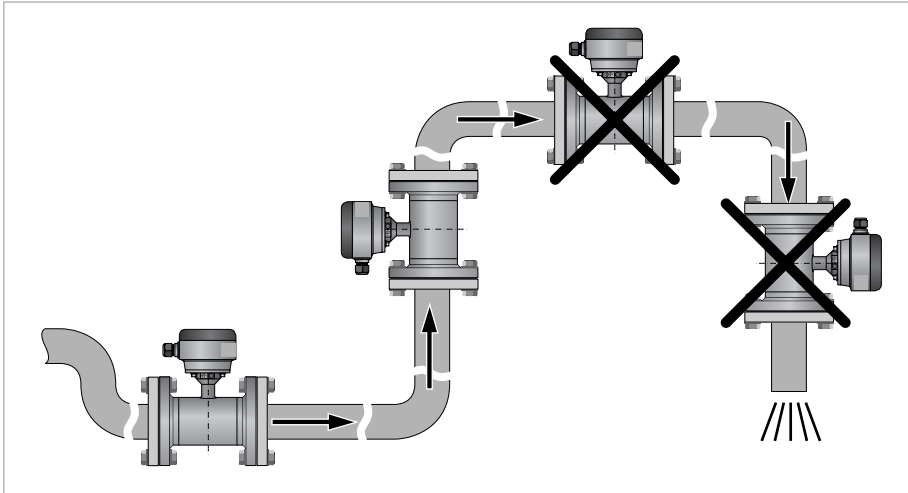

Figure 3-6: Installation in bending pipes

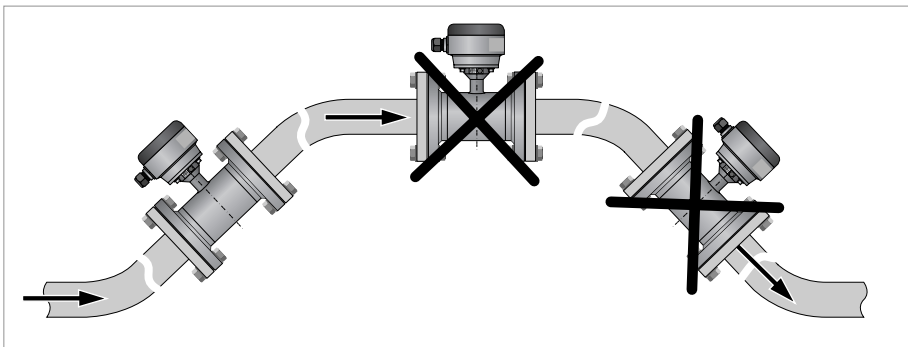

Figure 3-7: Installation in bending pipes

Avoid draining or partial filling of the flow sensor

3.3.5 Open feed or discharge

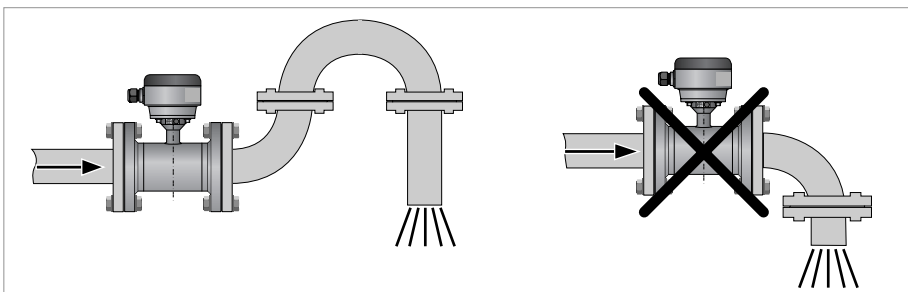

Figure 3-8: Installation in front of an open discharge

3.3.6 Control valve

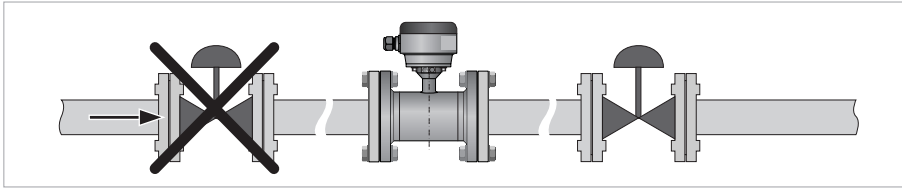

Figure 3-9: Installation in front of a control valve

3.3.7 Pump

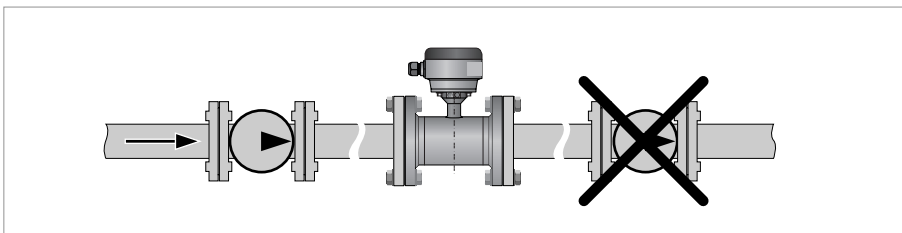

Figure 3-10: Installation behind a pump

3.3.8 Air venting and vacuum forces

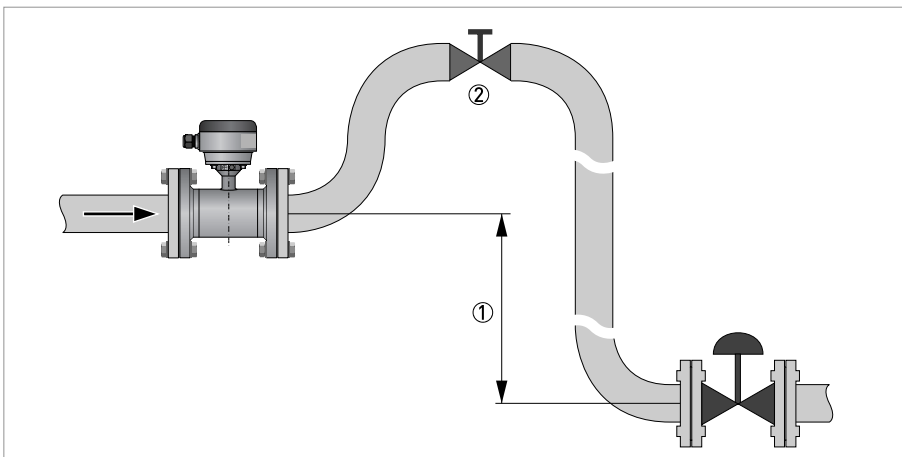

Figure 3-11: Air venting

- ① ≥ 5 m
- ② Air ventilation point

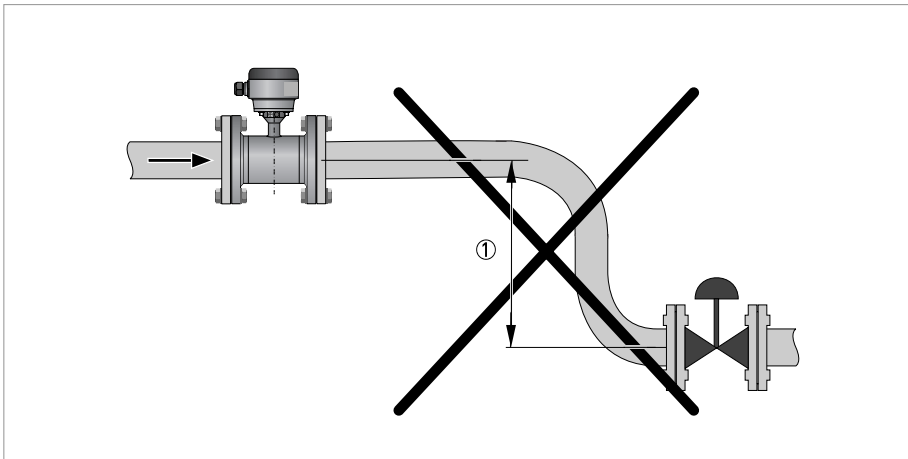

Figure 3-12: Vacuum

① ≥ 5 m

3.3.9 Flange deviation

Max. permissible deviation of pipe flange faces:
 $L_{max} - L_{min} \leq 0.5 \text{ mm} / 0.02''$

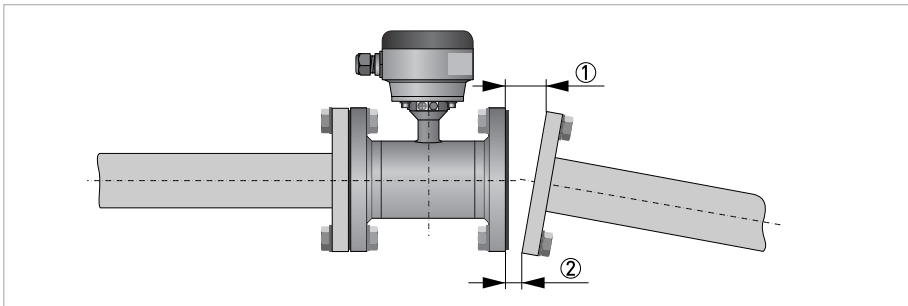

Figure 3-13: Flange deviation

① L_{max}
 ② L_{min}

3.3.10 Mounting position

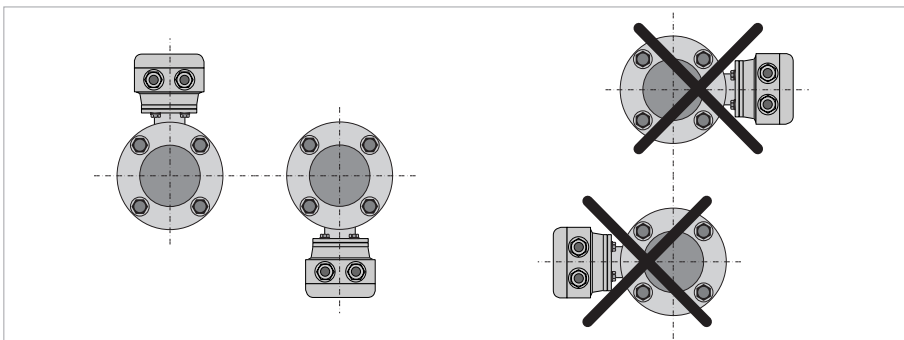

Figure 3-14: Mounting position

3.3.11 Mounting

3.3.12 Torques and pressures

Tighten the bolts in fixed order, see picture:

- Step 1: by hand
- Step 2: approx. 10% of max. torque
- Step 3: approx. 25% of max. torque
- Step 4: approx. 50% of max. torque
- Step 5: approx. 80% of max. torque
- Step 6: 100% of max. torque given in table

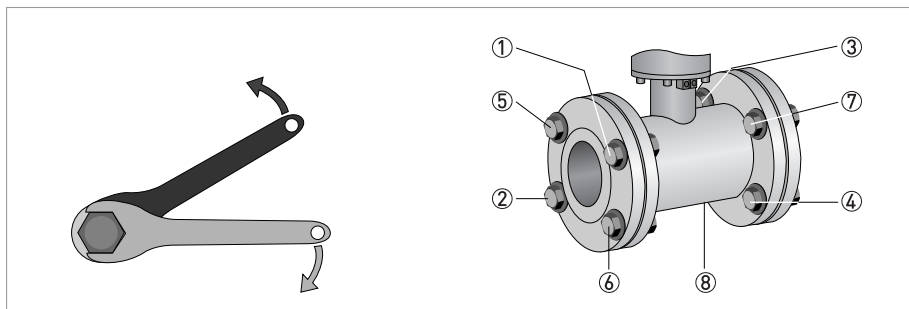

Diameters DN80 to DN300 have more bolts than the drawing in the picture above shows. Please continue in the same sequence to tighten the other bolts.

With the instrument, 4 PTFE gaskets are delivered (2 to be used with installation, 2 as spare). There are no other gaskets required.

The specified torque values are dependent on variables (temperature, bolt material, gasket material, lubricants, etc.) which are not within the control of the manufacturer. Therefore the values should be regarded as indicative only.

The torque values in the following tables are based 8.8 bolts and a friction coefficient 0.14.

EN 1092-1

Nominal size DN [mm]	Pressure rating	Bolts	Recommended torque [Nm]	
			Min.	Max.
15	PN 40	4 × M 12	50	70
25	PN 40	4 × M 12	50	70
40	PN 40	4 × M 16	100	175
50	PN 40	4 × M 16	100	175
80	PN 40	8 × M 16	100	175
100	PN 16	8 × M 16	100	175
150	PN 16	8 × M 20	200	340
200	PN 10	8 × M 20	200	340
250	PN 10	12 × M 20	250	340
300	PN 10	12 × M 20	250	340

ASME B 16.5

Nominal size [inch]	Flange class [lb]	Bolts	Recommended torque [ftlb]	
			Min.	Max.
1/2	300	4 × 1/2"	40	80
1	150 / 300	4 × 1/2"	40	80
1 1/2	150 / 300	4 × 1/2"	60	80
2	150 / 300	4 × 5/8"	80	160
3	150 / 300	4 × 5/8"	100	160
4	150	8 × 5/8"	100	160
6	150	8 × 3/4"	150	280
8	150	8 × 3/4"	200	280
10	150	12 × 7/8"	250	450
12	150	12 × 7/8"	300	450

4.1 Safety instructions

All work on the electrical connections may only be carried out with the power disconnected. Take note of the voltage data on the nameplate!

Observe the national regulations for electrical installations!

For devices used in hazardous areas, additional safety notes apply; please refer to the Ex documentation.

Observe without fail the local occupational health and safety regulations. Any work done on the electrical components of the measuring device may only be carried out by properly trained specialists.

Look at the device nameplate to ensure that the device is delivered according to your order. Check for the correct supply voltage printed on the nameplate.

4.2 Grounding

The device must be grounded in accordance with regulations in order to protect personnel against electric shocks.

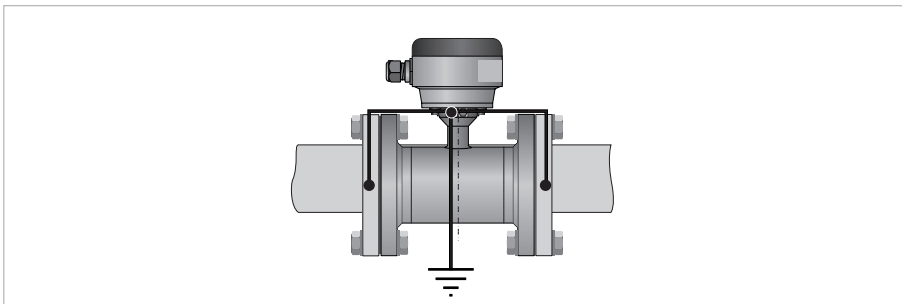

Figure 4-1: Grounding

① Metal pipelines, not internally coated. Grounding without grounding rings.

Grounding can be omitted with Virtual Reference (option on IFC 300 converter). For detailed information refer to Virtual reference for IFC 300 (C, W and F version) on page 26

4.3 Virtual reference for IFC 300 (C, W and F version)

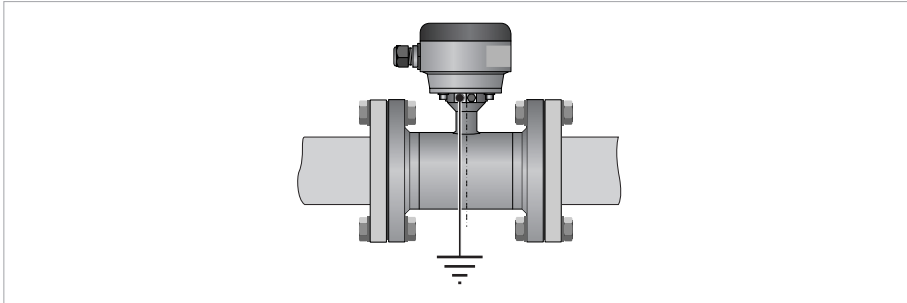

Figure 4-2: Virtual reference

Minimum requirements:

- Size: \geq DN10
- Electrical conductivity: \geq 200 μ S/cm
- Signal cable: max. 50 m / 164 ft, type DS

4.4 Connection diagrams

For the connection diagrams please refer to the documentation of the applicable signal converter.



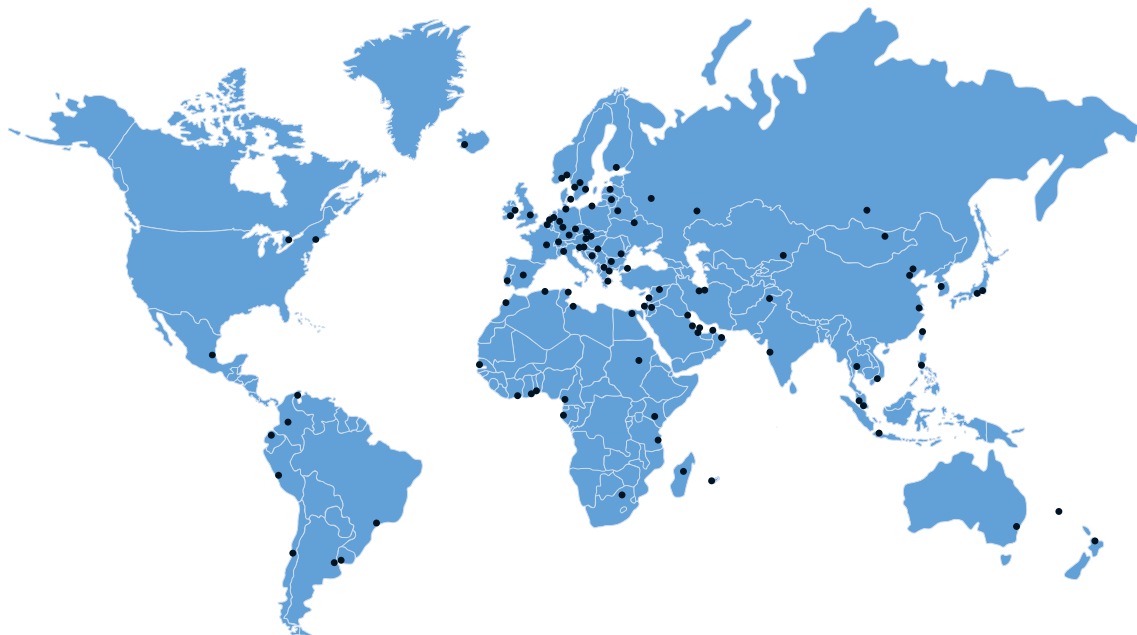

KROHNE – Process instrumentation and measurement solutions

- Flow
- Level
- Temperature
- Pressure
- Process Analysis
- Services

Head Office KROHNE Messtechnik GmbH
Ludwig-Krohne-Str. 5
47058 Duisburg (Germany)
Tel.: +49 203 301 0
Fax: +49 203 301 10389
info@krohne.com

The current list of all KROHNE contacts and addresses can be found at:
www.krohne.com

KROHNE