

Fisher™ CAV4 Control Valve

Contents

Introduction	1
Scope of Manual	1
Description	2
Educational Services	3
Specifications	3
Installation	4
Principle of Operation	5
Maintenance	6
Packing Lubrication	7
Packing Maintenance	8
Packing Replacement	8
Trim Removal	11
Trim Replacement	15
Use of Optional Flushing Trim	19
Parts Ordering	20
Parts Kits	20
Parts List	23

Figure 1. Fisher CAV4 Control Valve with 657 Actuator

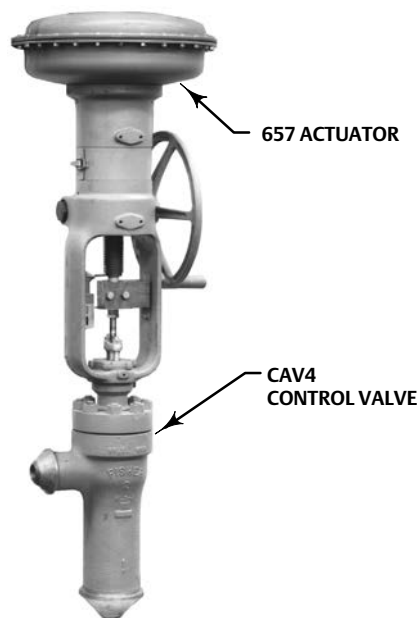

W2700-1*

Introduction

Scope of Manual

This manual includes installation, maintenance, and parts ordering information for the Fisher CAV4 control valve and Cavitrol™ IV trim. Information on the flushing trim is also provided. Refer to separate manuals for information concerning the actuator, positioner, and other accessories used with this control valve.

Do not install, operate, or maintain a CAV4 control valve without being fully trained and qualified in valve, actuator, and accessory installation, operation, and maintenance. To avoid personal injury or property damage, it is important to carefully read, understand, and follow all the contents of this manual, including all safety cautions and warnings. If you have any questions about these instructions, contact your [Emerson sales office](#) or Local Business Partner before proceeding.

Table 1. Specifications

<p>Available Configurations and Valve Sizes</p> <p>Common Characteristics: Four-stage Cavitrol IV trim with soft metal-to-metal seats in CAV4 angle valve. Valve plug action is push-down-to-close</p> <p>Seal Ring Construction: NPS 2, 3, 4, or 6 valve with pressure-balanced valve plug and spring-loaded PTFE seal ring. For use in low-temperature applications</p> <p>Stem-Balanced Construction: NPS 2 or 4 valve with stem-balanced valve plug (valve stem diameter--for that portion of the stem that passes through the bonnet--is equal to the nominal port diameter). For use in high-temperature applications</p> <p>Piston Ring Construction: NPS 6 valve with pressure-balanced valve plug and five graphite piston rings. For use in high temperature applications</p> <p>Maximum Inlet Pressure, Temperature, and Pressure Drops⁽¹⁾</p> <p>Consistent with ASME B16.34 CL2500 pressure/temperature ratings; but do not exceed the pressure, temperature, and pressure drop conditions specified when the valve was ordered. Also, see the Installation section in this manual</p> <p>End Connection Style</p> <p>Buttwelding Ends: All buttwelding end schedules per ASME B16.25 that are compatible with ASME B16.34 valve body rating.</p> <p>Raised-Face or Ring-Type Joint Flanged Ends: Inlet connection is CL2500 flange per B16.5. Outlet connection mates to CL2500 flange and has tapped bolt holes with line flange studs</p>	<p>Shutoff Classification</p> <p>TSO (Tight Shutoff) Trim: Valves with TSO trim are factory tested to a more stringent Emerson Automation Solutions test requirement of no leakage at time of shipment using ANSI/FCI 70-2 and IEC 60534-4 Class V procedures.</p> <p>Piston Ring Construction: Class IV per ANSI/FCI 70-2 and IEC 60534-4</p> <p>All Others: Class VI per ANSI/FCI 70-2 and IEC 60534-4</p> <p>Flow Direction</p> <p>In through the side connection and out the bottom connection</p> <p>Flow Characteristic</p> <p>Linear</p> <p>Port Diameters and Unbalance Area</p> <p>See table 2, or table 3 for TSO trim</p> <p>Minimum Seating Force</p> <p>First refer to figure 2 to determine minimum seat load in lbf per inch of port circumference, then multiply that value by the port circumference from table 2, or table 3 for TSO trim</p> <p>Valve Plug Travel</p> <p>See table 2</p> <p>Yoke Boss and Valve Stem Diameters</p> <p>See table 2</p> <p>Approximate Weights</p> <p>See table 4</p>
--	---

1. The pressure/temperature limits in this manual and any applicable standard or code limitation for the valve should not be exceeded.

Description

The CAV4 control valve, shown in figure 1, is an angle valve with soft metal-to-metal seats, Cavitrol IV trim, cage guiding, and push-down- to-close valve plug action. Figures 6 and 8 show a typical balanced TSO (tight shutoff) trim construction. Figure 13 shows three additional valve plug constructions that are available: one with a pressure-assisted spring-loaded PTFE seal ring with PEEK (poly ether ether ketone) anti-extrusion rings, another with five graphite piston rings, and a third with stem-balancing.

Cavitrol IV trim is most often used to help eliminate cavitation damage on liquid service where the differential pressure drop is greater than 207 bar, differential (3000 psi). It may also be used in applications with lower pressure drops where its anti-cavitation performance is required. Figure 14 shows the valve with flushing trim. Flushing trim consists of two plates installed prior to system flushing in order to protect Cavitrol IV trim and valve body gasket surfaces.

Earlier CAV4 control valves used hard metal-to-metal seats. The soft metal-to-metal seated version can be identified by the letters SMS stamped on the seat ring (key 35, figure 13) or lower cage assembly (key 2, figure 13).

Educational Services

For information on available courses for the Fisher CAV4 valve, as well as a variety of other products, contact:

Emerson Automation Solutions
 Educational Services - Registration
 Phone: 1-641-754-3771 or 1-800-338-8158
 E-mail: education@emerson.com
 emerson.com/fishervalvetraining

Specifications

Specifications for the CAV4 control valve are shown in tables 1, 2, and 4.

Table 2. Additional Valve Specifications

VALVE SIZE, NPS	VALVE STEM DIAMETER		YOKE BOSS DIAMETER		TRAVEL		PORT DIAMETER		PORT CIRCUMFERENCE		UNBALANCE AREA ⁽¹⁾	
	mm	Inch	mm	Inch	mm	Inch	mm	Inch	mm	Inch	mm ²	Inch ²
2	19.0 38.1	3/4 1-1/2 ⁽²⁾	91 127	3-9/16 5	38	1.5	38.1	1.5	119.6	4.71	4.3	0.17
3	19.0	3/4	91	3-9/16	51	2	55.6	2.1875	174.5	6.87	6.6	0.26
4	19.0 25.4 69.8	3/4 1 2-3/4 ⁽³⁾	91 127 178	3-9/16 5 7	64	2.5	69.9	2.75	219.4	8.64	8.1	0.32
6	31.7	1-1/4	127	5 & 5H	102	4	111.1	4.375	349.2	13.75	12.9	0.51

1. For seal ring and piston ring constructions. For stem-balanced construction, use port area of 11.4 cm² (1.77 inch²) for NPS 2 valve and 38.3 cm² (5.94 inch²) for NPS 4 valve.
 2. Stem-balanced construction has 31.8 mm (1-1/4 inch) valve stem connection.
 3. Stem-balanced construction has 50.8 mm (2 inch) valve stem connection.

Table 3. Additional Valve Specifications for TSO (Tight Shutoff) Trim

VALVE SIZE, NPS	MAXIMUM TRAVEL		YOKE BOSS SIZE ⁽¹⁾		PORT DIAMETER				PORT CIRCUMFERENCE		C _v REDUCTION AT 100% TRAVEL ⁽²⁾
	mm	Inch	mm	Inch	Nominal		Actual TSO		mm	Inch	
					mm	Inch	mm	Inch			
2	38	1.5	91 127	3-9/16 5	38.1	1.5	38.1	1.5	119.6	4.71	0%
3	50.8	2	91	3-9/16	55.6	2.1875	55.6	2.1875	174.5	6.87	0%
4	64	2.5	91 127	3-9/16 5	69.9	2.75	69.9	2.75	219.4	8.64	0%

1. Consult the factory for larger yoke boss sizes.
 2. This column lists the percent reduction of published maximum C_v of the trim listed in the TRIM column.

Table 4. Approximate Weights

VALVE SIZE, NPS	YOKE BOSS DIAMETER		TOTAL		BONNET ONLY		VALVE PLUG AND STEM ASSEMBLY		LOWER CAGE ASSEMBLY		UPPER CAGE	
	mm	Inch	Kg	Lb	Kg	Lb	Kg	Lb	Kg	Lb	Kg	Lb
2	91	3-9/16	167	369	44	98	3	7	12	27	4	9
	127	5	182	401	59	130	3	7	12	27	4	9
3	91	3-9/16	301	664	47	103	5	12	14	30	7	16
4	91 or 127	3-9/16 or 5	532	1172	127	280	12	27	37	82	12	27
	178	7	554	1222	150	330	12	27	37	82	12	27
6	127	5 or 5H	1512	3334	240	530	44	98	84	186	54	120

Installation

⚠ WARNING

Always wear protective gloves, clothing, and eyewear when performing any installation operations to avoid personal injury.

Personal injury or system damage caused by sudden release of pressure may result if the valve assembly is installed where service conditions could exceed the limits given in table 1 and on the appropriate nameplates. To avoid such injury or damage, use pressure-relieving devices as required by applicable industry codes to prevent the service conditions from exceeding these limits.

Check with your process or safety engineer for any additional measures that must be taken to protect against process media.

If installing into an existing application, also refer to the WARNING at the beginning of the Maintenance section in this instruction manual.

CAUTION

The valve configuration and construction materials were selected to meet particular pressure, pressure drop, temperature, and controlled fluid conditions indicated when the valve was ordered. Do not apply any other conditions to the valve without first contacting your [Emerson sales office](#) or Local Business Partner.

Trim parts, seals, and gaskets may be damaged if post-weld buttweld heat treatment is applied to valve areas other than the end connections. If heat treatment will be performed over the entire valve body, seals and gaskets must be removed. Valve plug seals may be reused; gaskets that are removed must not be reused. Use new gaskets upon assembly.

If hoisting the valve, be sure the hoist used is capable of handling the weight of the valve and actuator. Also, be sure the sling does not damage the painted surfaces, is positioned securely to prevent swinging or slipping, and is positioned so as to cause no damage to tubing or any accessories.

1. The valve must be installed so that the actuator is positioned vertically above the valve body. This position reduces the possibility of uneven wear on the valve plug. Also, this position facilitates easier maintenance and prevents stem binding due to actuator weight.
2. Be certain the valve body and adjacent pipelines are free of foreign materials that may damage valve seating surfaces.
3. If continuous operation of the system will be required during valve inspection and maintenance, install a conventional three-valve bypass around the point of valve installation.

CAUTION

For long service life and more effective operation, the process liquid must be clean. Impurities or entrained solids in the process liquid may cause irreparable erosion damage to the seating surfaces and may plug cage holes, causing cavitation damage. During valve installation or the plant cleaning cycle, install a strainer upstream from the valve to help free pipelines of foreign material.

4. Flow through the valve must be as indicated by the flow direction arrow on the valve body.
5. Use accepted piping practices when installing the valve in the pipeline. For flanged valves, remove the protective covering from the outlet flange studs, and use a suitable gasket between the valve and the pipeline flanges.

⚠ WARNING

Personal injury could result from packing leakage. Valve packing was tightened prior to shipment; however, the packing might require some readjustment to meet specific service conditions.

Figure 2. Recommended Minimum Seat Load for All Constructions

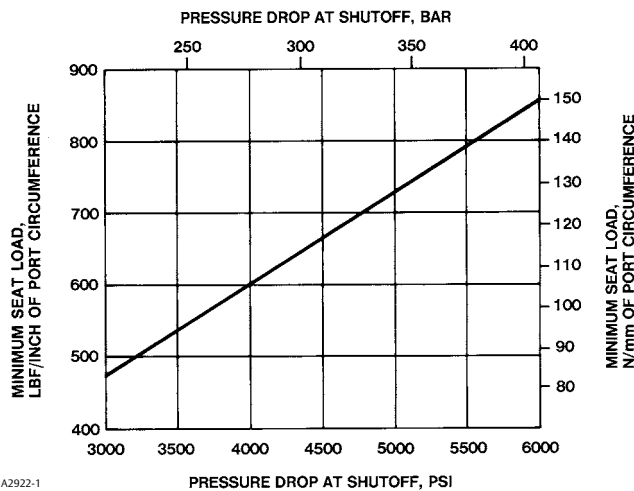

A2922-1

Flushing the Pipeline

Before flushing the piping system, install the CAV4 flushing trim (figure 14), if available, as described in the Use of Optional Flushing Trim procedure in the Maintenance section.

Principle of Operation

With Cavitrol IV trim, liquid flow enters the valve through the side connection and enters the cage through the top set of holes as shown in figure 3. No significant pressure drop occurs across the set of holes because the flow area is relatively large. As the liquid flows down through the cage, it undergoes four staged pressure drops by flowing through four additional sets of holes. All significant throttling action occurs in the four sets of holes down-stream of the seating surfaces. Flow leaves the valve through the bottom connection.

When the valve is partially open, the valve plug blocks some of the holes above the seating surfaces. A small amount of flow enters the blocked holes and flows out through the clearance between the cage and plug. Because all significant pressure drop is taken downstream of the seating surfaces, the clearance flow does not cavitate or cause erosion of the seating surfaces. Each of the four stages has a successively larger flow area, resulting in higher pressure drops across the first stages where there is no danger of the liquid pressure falling low enough to allow the formation of vapor bubbles that can cause cavitation.

Because more than 90 percent of the total valve pressure drop is across the first three stages, both the inlet pressure to the final stage and the pressure drop across the final stage are relatively low. A low inlet pressure and pressure drop at the final stage result in a pressure at the vena contracta (the lowest pressure reached in the flow stream) that is above the liquid vapor pressure. Maintaining this higher pressure at the vena contracta ensures that the liquid pressure does not fall below the vapor pressure, and thus cavitation does not occur.

Maintenance

Valve parts are subject to normal wear and must be inspected and replaced as necessary. Inspection and maintenance frequency depends on the severity of service conditions. This section includes instructions for packing lubrication, packing replacement, trim removal, trim replacement, and use of flushing trim.

Key numbers used in these procedures are shown in figure 13, except where indicated.

Figure 3. Schematic of CAV4 Valve with Cavitrol IV Trim

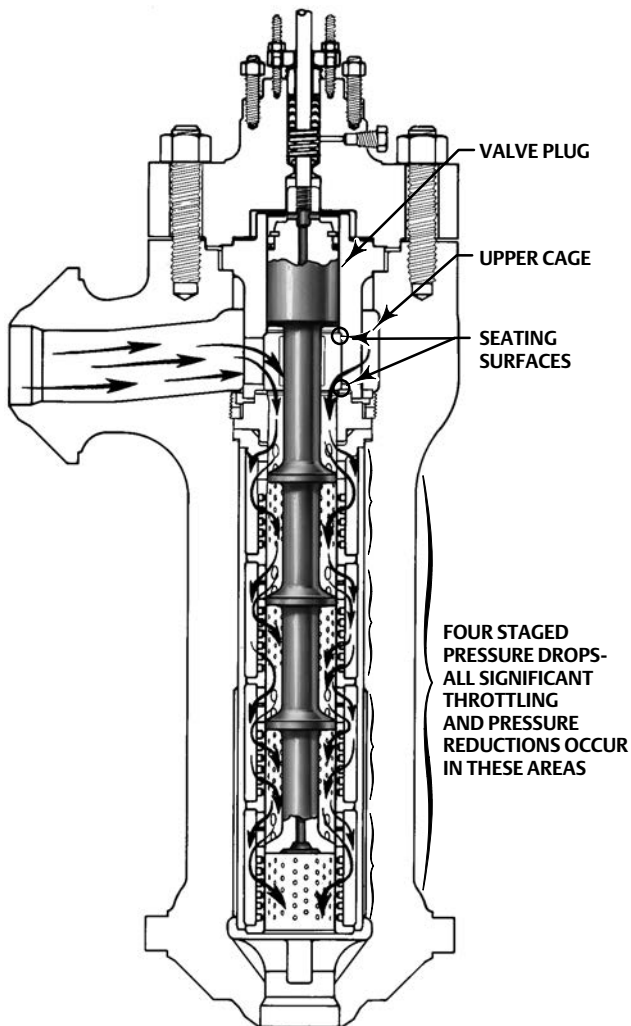

W3671-3

⚠ WARNING

Avoid personal injury and property damage from sudden release of process pressure or bursting of parts. Before performing any maintenance operations:

- Do not remove the actuator from the valve while the valve is still pressurized.
- Always wear protective gloves, clothing, and eyewear when performing any maintenance operations to avoid personal injury.

- Disconnect any operating lines providing air pressure, electric power, or a control signal to the actuator. Be sure the actuator cannot suddenly open or close the valve.
- Use bypass valves or completely shut off the process to isolate the valve from process pressure. Relieve process pressure on both sides of the valve. Drain the process media from both sides of the valve.
- Vent the power actuator loading pressure, and relieve any actuator spring precompression.
- Use lock-out procedures to be sure that the above measures stay in effect while you work on the equipment.
- The valve packing box may contain process fluids that are pressurized, *even when the valve has been removed from the pipeline*. Process fluids may spray out under pressure when removing the packing hardware or packing rings, or when loosening the packing box pipe plug.
- Check with your process or safety engineer for any additional measures that must be taken to protect against process media.

Figure 4. Optional Lubricator and Lubricator/Isolating Valve

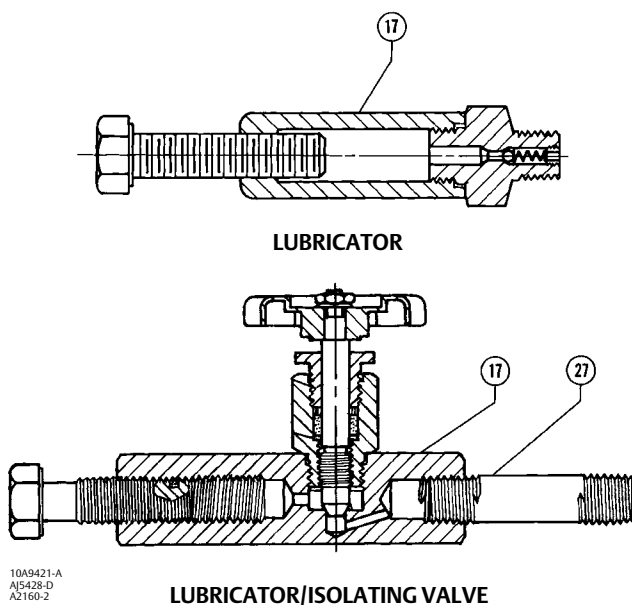

Packing Lubrication

CAUTION

Do not lubricate graphite packing. Graphite packing is self-lubricated. Additional lubrication may result in slip-stick movement of the valve.

Note

To avoid lubricants breaking down at elevated temperatures, do not lubricate packing used in processes with temperatures over 260°C (500°F).

A lubricator or lubricator/isolating valve (figure 4) is available for use with PTFE-composition packing or other packings that require lubrication. If a lubricator or lubricator/isolating valve is used, it will be installed in place of the pipe plug (key 17) in the bonnet (key 12).

Use a good quality silicon-base lubricant. Packing used in processes with temperatures over 260°C (500°F) should not be lubricated. Be certain the lubricant is compatible with the process liquid. The frequency of lubrication depends upon the severity of the service conditions.

To operate the lubricator, simply turn the cap screw clockwise to force lubricant into the packing box. The lubricator/isolating valve operates the same way except the isolating valve must first be opened and then closed after lubrication is completed.

Table 5. Recommended Torque for Packing Flange Nuts

STEM DIAMETER		MINIMUM		MAXIMUM	
mm	Inch	N•m	Lbf•ft	N•m	Lbf•ft
19.1	3/4	41	30	61	45
25.4	1	61	45	91	67
31.8	1-1/4	81	60	122	90
38.1	1-1/2	61	45	91	67
69.9	2-3/4	81	60	122	90

Packing Maintenance

For spring-loaded single PTFE V-ring packing (figure 5), the spring (key 23) maintains a sealing force on the packing. If leakage is noted around the packing follower (key 22), check to be sure the shoulder on the packing follower is touching the bonnet. If the shoulder is not touching the bonnet, tighten the packing flange nuts (key 15) until the shoulder is against the bonnet. If leakage cannot be stopped in this manner, replace the packing as described in the Packing Replacement procedure.

For PTFE-composition or graphite ribbon/filament packing (figure 5), leakage around the packing follower may be stopped by tightening the packing flange nuts (key 15). If leakage cannot be stopped by tightening the nuts, replace packing as described in the Packing Replacement procedure.

Packing Replacement

▲ WARNING

Refer to the **WARNING** at the beginning of the Maintenance section.

For spring-loaded PTFE V-ring packing (shown in figure 5), tighten the packing flange nuts (key 15) until the shoulder on the packing follower (key 22, figure 5) contacts the bonnet (key 12). If packing leakage still exists, replace the packing according to the numbered steps below.

If packing leakage exists with PTFE-composition or graphite ribbon/filament packing, first try to limit the leakage and establish a stem seal by tightening the packing flange nuts (key 15) to at least the minimum recommended torque in table 5. However, do not exceed the maximum recommended torque in table 5, or excessive friction may result.

If the packing is relatively new and tight on the stem, and if tightening the packing flange nuts does not stop the leakage, the valve stem may be worn or nicked so that a seal cannot be made. The surface finish of a new valve stem is 0.1 micro-meter (4 micro-inches) rms. If the leakage comes from the outside diameter of the packing, the leakage may be caused by nicks or scratches around the packing box wall. While replacing the packing according to the numbered steps below, inspect the valve stem and packing box wall for nicks or scratches. If the nicks or scratches cannot be removed by refinishing, replace the parts with new parts.

1. Remove the cap screws in the valve/actuator stem connector (not shown), and separate the two halves of the stem connector. Then exhaust all actuator pressure, if any was applied, and disconnect the actuator supply and any leakoff piping.

2. Unscrew the hex nuts (key 26) or the yoke locknut (not shown), and lift the actuator from the bonnet (key 12).
3. Loosen the packing flange nuts (key 15) so that the packing (key 19 or keys 29 and 13, figure 5) is not tight on the valve stem (key 4). Remove any travel indicator disc and stem locknuts from the valve stem threads.

Figure 5. Packing Arrangements

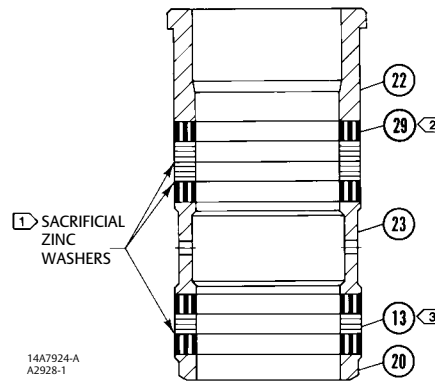
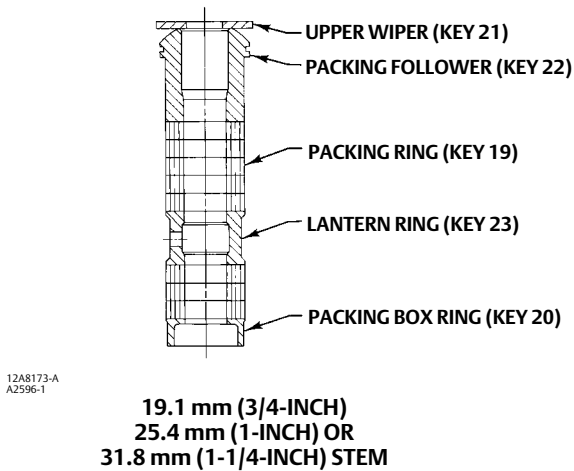
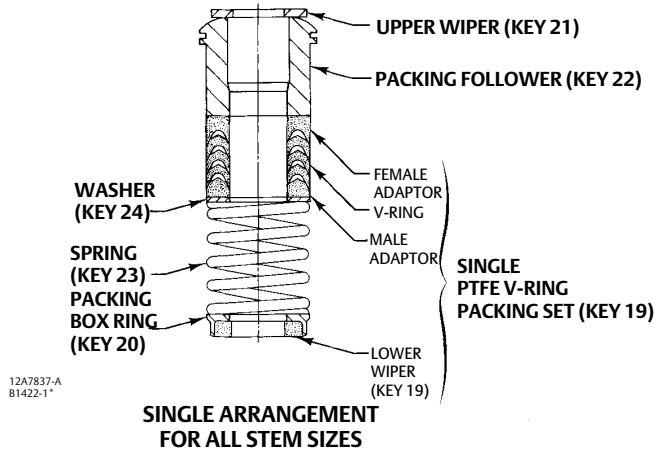

- NOTES:
- 1 ONLY 0.102mm (0.004 INCH) THICK; USE ONLY ONE BELOW EACH GRAPHITE RING.
 - 2 HAS THE APPEARANCE OF A WOVEN OR BRAIDED RING.
 - 3 HAS THE APPEARANCE OF FLAT WASHERS PRESSED TOGETHER.

**GRAPHITE PACKING FOR 31.8, 38.1, & 69.9 mm
(1-1/4, 1-1/2, & 2-3/4 INCH) STEM DIA**

Table 6. Valve Body-to-Bonnet Bolting Torque

VALVE SIZE, NPS	TORQUE	
	N•m	Lbf•ft
2	974	717
3	1058	780
4	1776	1310
6	2712	2000

CAUTION

When lifting the bonnet (key 12), be sure that the valve plug and stem assembly (key 4) remains on the seat. This will avoid damage to the seating surfaces as a result of the assembly dropping from the bonnet after being lifted part way out. The bonnet is easier to handle separately.

When removing packing, use care to avoid scratching the packing box wall.

4. Unscrew the large hex nuts (key 27) that secure the bonnet (key 12) to the valve body. Carefully lift the bonnet off the valve stem. If the valve plug and stem assembly (key 4) starts to lift with the bonnet, tap the end of the stem down with a brass or similar hammer that will not deform the valve stem threads. Set the bonnet on a cardboard or wooden surface to prevent damage to the bonnet gasket surface.
5. Remove the upper bonnet gasket (key 6).
6. Cover the opening in the valve body to protect the gasket surface and to prevent foreign material from falling into the valve body cavity.
7. Remove the packing flange nuts (key 15), packing flange (key 16), upper wiper (key 21, figures 5 and 13, not used with graphite ribbon/filament packing), and packing follower (key 22). Carefully push out all the remaining packing parts from the valve side of the bonnet using a rounded rod or other tool that will not scratch the packing box wall.
8. Clean the packing box and these metal packing parts: packing follower (key 22), packing box ring (key 20), spring and special washer (keys 23 and 24, used with PTFE V-ring packing, figure 5) or lantern ring (key 23, used with other packing as shown in the figure 5 arrangements).
9. Inspect the valve stem threads for any sharp edges that might cut the packing. A whetstone or emery cloth may be used to smooth the threads if necessary.
10. Remove the protective covering from the valve body cavity, and install a new upper bonnet gasket (key 6). Then slide the bonnet (key 12) over the stem and onto the stud bolts (key 28).

Note

Stud(s) and nut(s) should be installed such that the manufacturer's trademark and material grade marking is visible, allowing easy comparison to the materials selected and documented in the Emerson/Fisher serial card provided with this product.

⚠ WARNING

Personal injury or damage to equipment could occur if improper stud and nut materials or parts are used. Do not operate or assemble this product with stud(s) and nut(s) that are not approved by Emerson/Fisher engineering and/or listed on the serial card provided with this product. Use of unapproved materials and parts could lead to stresses exceeding the design or code limits intended for this particular service. Install studs with the material grade and manufacturer's identification mark visible. Contact your [Emerson sales office](#) or Local Business Partner immediately if a discrepancy between actual parts and approved parts is suspected.

11. Lubricate the stud bolt (key 28) threads and the faces of the hex nuts (key 27) with anti-seize lubricant (key 18) (not necessary if new factory prelubricated hex nuts are used). Replace the washers and hex nuts, but do not tighten them. Torque the nuts in a crisscross pattern to no more than 1/4 of the nominal torque value specified in table 6. When all nuts are tightened to that torque value, increase the torque by 1/4 of the specified nominal torque and repeat the crisscross pattern. Repeat this procedure until all nuts are tightened to the specified nominal value. Apply the final torque value again and, if any nut still turns, tighten every nut again.

12. Install new packing and the metal packing box parts according to the appropriate arrangement in figure 5. Slip a smooth-edged pipe over the valve stem, and gently tamp each soft packing part into the packing box.
13. Slide the packing follower (key 22), wiper (key 21, not used with graphite ribbon/filament packing), and packing flange (key 16) into position. Lubricate the packing flange studs (key 14) and the faces of the packing flange nuts (key 15). Replace the packing flange nuts.

For spring-loaded PTFE V-ring packing, tighten packing flange nuts (key 15) until the shoulder on the packing follower (key 22) contacts the bonnet (key 12).

For other packing types, tighten the packing flange nuts (key 15) to the maximum recommended torque shown in table 5. Then loosen the packing flange nuts, and retighten them to the recommended minimum torque in the table.

14. Mount the actuator on the valve body assembly, and reconnect the actuator and valve stem according to the procedures in the appropriate actuator instruction manual. After the valve is returned to service, retighten the hex nuts (key 27) to the torques listed in table 6.

Trim Removal

Note

The NPS 3 CAV4 valve is a clamped-in trim design. No cage retainer is used. See figure 13. Therefore, if you are using these instructions for an NPS 3 valve, disregard references to a cage retainer.

The valve trim consists of the valve plug and stem assembly (key 4), the valve plug rings, if used, (keys 8, 9, 10, 11, and 37), the upper cage (key 3), the cage retainer (key 5), the lower cage assembly (key 2), the separable seat ring (key 35, seal ring construction only), the upper and lower bonnet gaskets (key 6), and the cage gasket (key 7).

Figure 6. TSO (Tight Shutoff) Trim, Detail of Protected Soft Seat

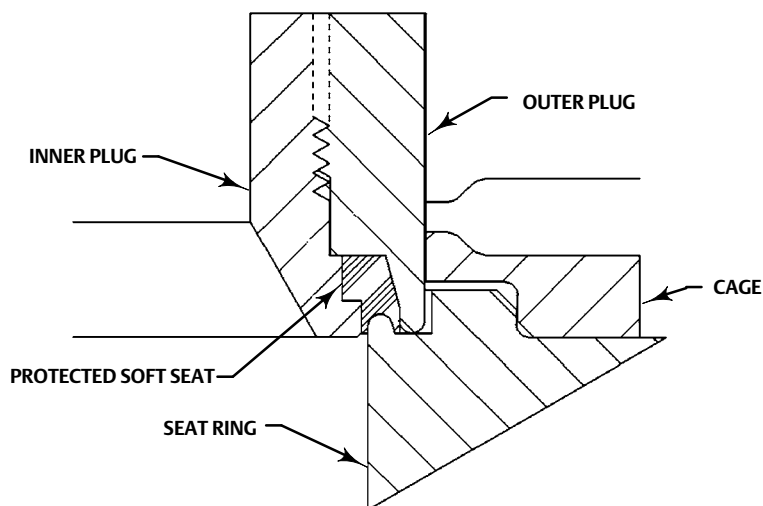

A7088

During trim removal, inspect the seating surface of the plug and lower cage or seat ring. Also inspect the inside diameter of the lower cage. If the seating surfaces need to be refinished, or if the inside diameter of the lower cage has plugged holes, deep scratches, or other signs of wear, the cage retainer and lower cage assembly must be removed. A seat ring or lower cage assembly and cage retainer in good condition may both remain in the valve body.

Figure 7. Information for Machining and Use of Cage Retainer Tool

VALVE SIZE, NPS	TOOL DIMENSIONS																	
	A ⁽¹⁾		B		C		D		E		F ⁽¹⁾ Dia		G Dia		H Dia		I ⁽¹⁾	
	mm	Inch	mm	Inch	mm	Inch	mm	Inch	mm	Inch	mm	Inch	mm	Inch	mm	Inch	mm	Inch
2	9.7	.38	12.7	.50	38.1	1.50	12.7	.50	25.4	1.00	86.1 85.6	3.390 3.370	74.7	2.94	88.9	3.50	18.8 18.5	.740 .730
3	Not Applicable																	
4	11.2	.44	14.2	.56	36.6	1.44	15.8	.62	38.1	1.50	143.3 142.8	5.640 5.620	127.0	5.00	145.8	5.74	25.2 24.9	.990 .980
6	17.7 17.4	.695 .685	19.1	.75	54.0	2.12	31.8	1.25	88.9	3.50	201.7 201.5	7.942 7.932	182.6	7.19	205.7 205.5	8.100 8.090	25.2 24.9	.990 .980

1. Double dimensions indicate maximum and minimum values.

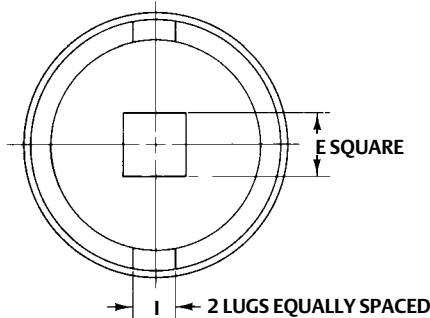
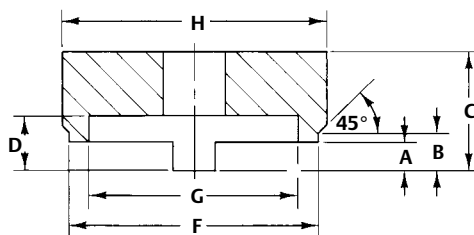

TOOL FOR NPS 2 AND 4 VALVE BODIES

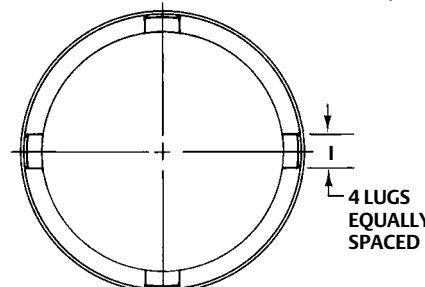
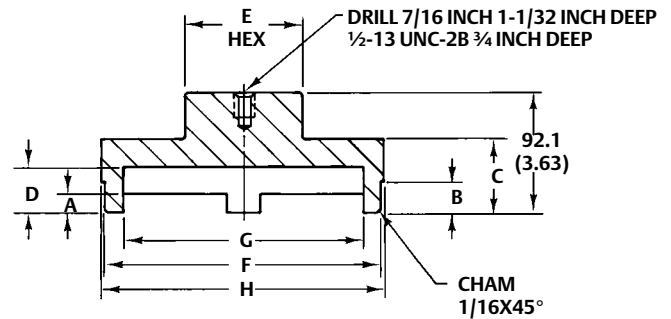

TOOL FOR NPS 6 VALVE BODY

mm (INCH)

VALVE SIZE, NPS	TORQUE	
	N•m	Lbf•ft
2	1356	1000
3	N.A.	N.A.
4	6100	4500
6	13,560	10,000

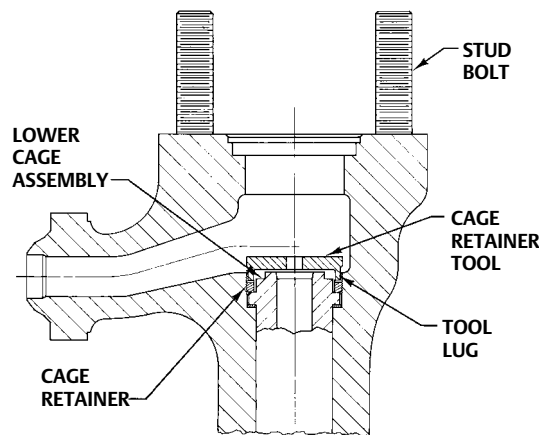

TOOL INSTALLATION

Recommended Materials	Minimum Rockwell Hardness
S41600	28
S17400	36
S41000	31

48A6264-A
A2929-1

Figure 8. Typical Balanced TSO Trim

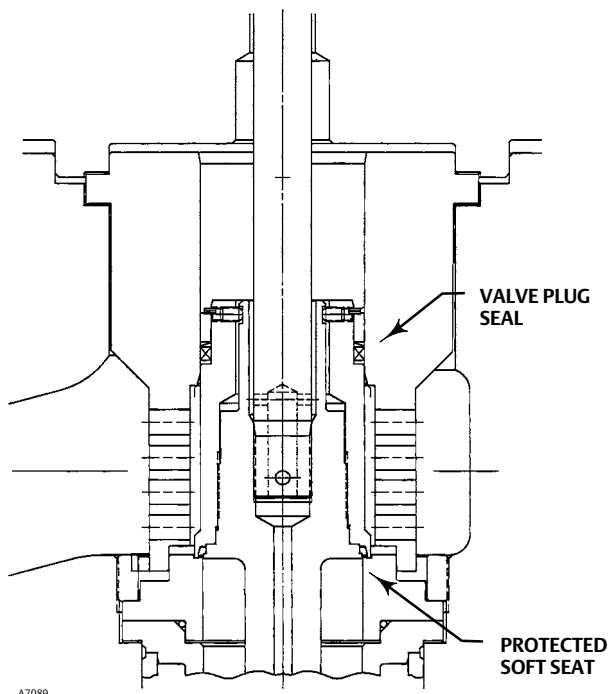

A cage retainer tool is required to remove the cage retainer and lower cage assembly. If specifically ordered, a tool is supplied with the valve. It can also be ordered individually by referencing the tool part number included in the Parts List of this manual. A tool can also be machined for a specific valve using the dimensions shown in figure 7.

Note

Machine the tool from a material listed in figure 7, or from a material with a yield strength of at least 827 MPa (120,000 psi). Using a tool of lower strength may result in damage to the valve body threads.

CAUTION

Careful handling and installation of trim parts is extremely critical on all CAV4 valves. Any damage to gasket and seal surfaces of the cage or valve body, or valve plug and cage seating surfaces can result in leakage that can cause eventual damage to the cage and valve body due to erosion and cavitation.

1. Remove the actuator (not shown), bonnet (key 12) and packing by following steps 1 through 7 of the Packing Replacement section.

CAUTION

When lifting the valve plug and stem assembly out of the valve body, be certain the upper cage (key 3) remains in the valve (key 1). This will prevent damage that might be caused by the upper cage dropping back into the valve after being lifted

part way out. Use care to avoid damaging gasket sealing surfaces. Lay the valve plug and stem assembly on a protective surface in a safe location.

The NPS 6 CAV4 graphite piston rings (key 11) are brittle and in two halves. Use care to avoid damage to the piston rings caused by dropping or rough handling.

2. Pull the valve plug and stem assembly (key 4) out of the cages. Lay it on a protective surface in a safe location.
3. For stem-balanced valve plugs, proceed to step 4.

For seal ring valve plugs, work the retaining ring (key 10) off the valve plug with a screwdriver. Carefully slide the backup ring (key 9), two-piece anti-extrusion ring (key 37), and seal ring (key 8) off the valve plug (key 4).

For piston-ring valve plugs, the graphite piston rings (key 11) are each in two halves. If the rings are worn and need to be replaced, remove the sections from the grooves in the valve plug (key 4).

For TSO (tight shutoff) trim, perform the following steps (refer to figures 6 and 8):

CAUTION

In the following steps, use care to avoid damaging the outer plug guide surfaces.

- Remove the piston ring, anti-extrusion rings, backup ring, and retainer.
 - Remove the set screws that lock the outer plug to the inner plug.
 - Using a strap wrench or similar tool, unscrew the outer plug from the inner plug. Do not damage the outer plug guide surfaces.
 - Remove the protected soft seat seal.
 - Inspect the parts for damage and replace if needed.
4. The upper cage (key 3) has two tapped holes to aid in removal. Refer to table 7 for the hole diameter and thread type. Install eyebolts or similar devices into those holes, then carefully lift the upper cage out of the valve body.
 5. Remove the lower bonnet gasket (key 6).

If removal of the lower cage assembly is necessary, use a cage retainer tool (figure 7) to remove the cage retainer (key 5) as follows:

- a. Insert the tool into the valve body. Be certain the tool lugs are engaged in the corresponding recesses in the retainer.

CAUTION

Do not use an impact wrench to remove or install the seat ring retainer. Damage to cage retainer, valve body threads, and lower cage could result.

- b. Use a power torque wrench having torque capabilities equal to or greater than those shown in figure 7. Connect the power torque wrench to a standard socket wrench extension or other suitable tool. This extension or tool

must fit snugly into the square hole or hex head of the cage retainer tool. Refer to figure 7 for square hole and hex head sizes.

- c. Insert the extension into the cage retainer tool.
- d. Use the stud bolts (key 28) to prevent the power torque wrench from rotating.

Table 7. Hole Diameter and Thread Type for Cage Removal

Valve Size, NPS	Upper Cage	Lower Cage Assembly
2	2 holes, 1/4-20 UNC	---
3	2 holes, 3/8-16 UNC	4 holes, 1/4-20 UNC
4	2 holes, 3/8-16 UNC	4 holes, 1/4-20 UNC
6	2 holes, 1/2-13 UNC	4 holes, 3/8-16 UNC

CAUTION

Hold the power torque wrench and attached socket wrench extension at right angles to the cage retainer when applying torque. Tilting the wrench and extension while applying torque causes the lugs on the cage retainer tool to suddenly disengage from the recesses in the retainer, damaging the retainer and the lower cage assembly (key 2).

- e. Remove the cage retainer (key 5).
 - f. Remove the seat ring (key 35) and O-ring (key 36), if used.
6. The NPS 4 and 6 lower cage assemblies (key 2) have tapped holes to aid in removal. Refer to table 7 for hole diameter and thread type. Install eyebolts or similar devices into these holes. Carefully lift the lower cage assembly (key 2) straight out of the valve body.
7. Remove the cage gasket (key 7).

CAUTION

The seat ring (key 35) or integral seat cage assembly (key 2) has a soft metal seat. To avoid damage to the seating surfaces, DO NOT lap this surface. If this area needs repair, contact your [Emerson sales office](#) or Local Business Partner for assistance.

Trim Replacement

Note

The NPS 3 CAV4 valve is a clamped-in trim design. No cage retainer is used. See figure 13. Therefore, if you are using these instructions for an NPS 3 valve, disregard references to a cage retainer.

After all trim maintenance has been completed, reassemble the trim by following the steps below.

Be certain that all gasketed surfaces are clean. Use new gaskets (keys 6 and 7) during assembly.

1. If the lower cage assembly (key 2) and cage retainer (key 5) remained in the valve body (key 1), proceed to step 4.

If these parts were removed, read the following caution and proceed to step 2:

CAUTION

To avoid galling or improper gasket loading that may result in leakage, thoroughly clean the threads and the gasket surfaces in the valve body (key 1), the valve body bore, and the cage retainer (key 5). Lubricate the surfaces indicated in figure 9 with the appropriate lubricant. Be certain to lubricate all of the following mating surfaces:

- cage retainer and valve body threads,
- bottom of the cage retainer and top of the flange on the lower cage assembly.

Do not lubricate the gasket surfaces.

Position the valve vertically and carefully lower the lower cage assembly into the valve body. When inserting the assembly, use an even motion; do not rock the lower cage assembly while installing it. Use care to avoid damaging the cage gasket (key 7).

2. Install a new cage gasket (key 7), and insert the lower cage assembly (key 2) into the valve body. If installing the separable seat ring (key 35), first install the O-ring (key 36) around the bottom diameter of the seat ring.
3. Thread the cage retainer (key 5) into the valve body. Use the cage retainer tool (figure 7) to tighten the cage retainer as follows:
 - a. Insert the tool into the valve body. Be certain the tool lugs are engaged in the corresponding recesses in the retainer.

Figure 9. Trim Surfaces Requiring Lubrication and Recommended Lubricants

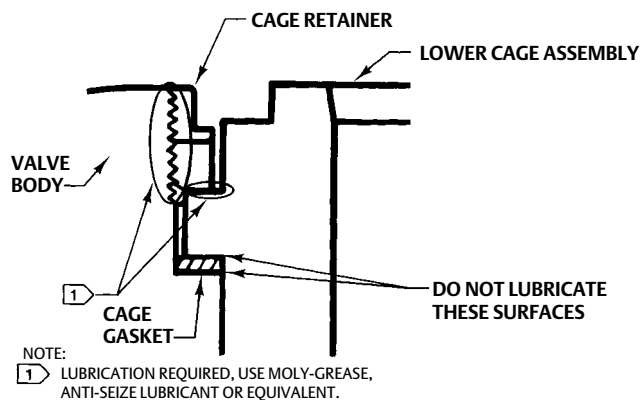

48A6264-A
A2935-1

CAUTION

Do not use an impact wrench to remove or install the seat ring retainer. Damage to cage retainer, valve body threads, and lower cage could result.

- b. Use a power torque wrench having torque capabilities equal to or greater than those shown in figure 7. Connect the power torque wrench to a standard socket wrench extension or other suitable tool. The extension or tool

must fit snugly into the square hole or the hex head of the cage retainer tool. Refer to figure 7 for square hole or hex head sizes.

- c. Insert the extension into the cage retainer tool.
- d. Use the stud bolts (key 28) to prevent the power torque wrench from rotating.

CAUTION

Hold the power torque wrench and attached socket wrench extension at right angles to the cage retainer when applying torque. Tilting the wrench and extension while applying torque causes the lugs on the cage retainer tool to suddenly disengage from the recesses in the retainer, damaging the retainer and lower cage assembly.

- e. Tighten the cage retainer (key 5) to the torque shown in figure 7.
4. Install a new lower bonnet gasket (key 6), and insert the upper cage (key 3). Be sure the lugs on the bottom of the cage engage the corresponding slots in the cage retainer (key 5).

Note

Rotate the upper cage (key 3) clockwise by hand as much as possible once the cage lugs engage the slots in the cage retainer (key 5). Failure to do so may result in slight seat leakage.

5. For stem-balanced valve plug, proceed to step 6.

For piston ring valve plug, if installing new graphite piston rings (key 11), each replacement ring will arrive in one piece. Use a vise with smooth jaws to break this replacement ring into halves. Place the new ring in the vise so that the jaws will compress the ring into an oval. Slowly compress the ring until the ring snaps on both sides. If one side snaps first, do not try to tear or cut the other side. Instead, keep compressing the ring until the other side snaps.

With the valve plug and stem assembly (key 4) on a protective surface, place the piston rings in the piston ring grooves with the fractured ends matched. Rotate the rings in the grooves so that all the matched ends are at different points around the plug circumference.

For seal ring valve plug, install the seal ring (key 8) with the open side facing the four flutes on the valve plug. Slide the 2-piece anti-extrusion ring (key 37) and the backup ring (key 9) onto the valve plug. Secure with the retaining ring (key 10).

For TSO (tight shutoff) trim, perform the following steps (refer to figures 6 and 8).

CAUTION

In the following steps, use care to avoid damaging the outer plug guide surfaces.

- Thread the outer plug onto the inner plug until the parts seat metal to metal, using a strap wrench or similar tool that will not damage the outer plug guide surfaces.
- Mark the top of the inner plug and outer plug with alignment marks in the assembled position.

- Disassemble the outer plug from the inner plug and install the seal over the inner plug, so that the seal rests below the threaded area.
 - Thread the outer plug onto the inner plug and tighten with a strap wrench or similar tool until the alignment marks line up. This will ensure that the plug parts are metal to metal and the seal is compressed properly. Do not damage the outer plug guide surfaces.
 - Install set screws centering the inner plug in the outer plug and torque to 11 N•m (8 lbf•ft).
 - Assemble the piston ring, anti-extrusion rings, backup ring, and retainer.
6. Slide the valve plug and stem assembly (key 4) into the cages.
 7. Place a new upper bonnet gasket (key 6) onto the upper cage (key 3) as shown in figure 13.
 8. Install the bonnet (key 12) over the valve stem and onto the valve body (key 1).

Note

Stud(s) and nut(s) should be installed such that the manufacturer's trademark and material grade marking is visible, allowing easy comparison to the materials selected and documented in the Emerson/Fisher serial card provided with this product.

⚠ WARNING

Personal injury or damage to equipment could occur if improper stud and nut materials or parts are used. Do not operate or assemble this product with stud(s) and nut(s) that are not approved by Emerson/Fisher engineering and/or listed on the serial card provided with this product. Use of unapproved materials and parts could lead to stresses exceeding the design or code limits intended for this particular service. Install studs with the material grade and manufacturer's identification mark visible. Contact your [Emerson sales office](#) or Local Business Partner immediately if a discrepancy between actual parts and approved parts is suspected.

9. Lubricate the threads of the studs (key 28) and the faces of the hex nuts (key 27) with anti-seize lubricant (key 18) (not necessary if new factory prelubricated hex nuts are used). Replace the washers and hex nuts but do not tighten them. Torque the nuts in a crisscross pattern to no more than 1/4 of the nominal torque value specified in table 6. When all nuts are tightened to that torque value, increase the torque by 1/4 of the specified nominal torque and repeat the crisscross pattern. Repeat this procedure until all nuts are tightened to the specified nominal value. Apply the final torque value again and, if any nut still turns, tighten every nut again.
10. Install new packing and packing box parts per steps 12 and 13 of the Packing Replacement section.
11. Mount the actuator by following the procedures in the appropriate actuator instruction manual. Check for packing leakage as the valve is being put into service. Retighten packing flange nuts as required. After the valve is returned to service, retighten the hex nuts (key 27) to the torque listed in table 6.

CAUTION

The soft metal seat life can be seriously shortened if the following step is not carefully completed.

12. Isolate the valve from the process and stroke the plug at least three times with maximum actuator force to seat the plug surface against the soft metal seat.

Use of Optional Flushing Trim

Install the optional flushing trim (figure 14) prior to system flushing in order to protect the Cavitrol IV trim and the valve body gasket surfaces.

Gaskets (keys 6 and 7) that have not been in service (i.e., original gaskets in a CAV4 valve being installed or new gaskets for a valve already installed) may be used with the flushing trim.

Key numbers referenced in this section are shown in figure 14, unless otherwise indicated.

1. Remove the actuator, and disassemble the valve body by completing steps 1 and 2, and 4 through 7 of the Trim Removal procedure.
2. Install the lower flushing plate (key 31).
3. Thread the cage retainer (key 5) into the valve body hand-tight.
4. Install the lower bonnet gasket (key 6), the upper flushing plate (key 30), and the upper bonnet gasket (key 6).

Note

Stud(s) and nut(s) should be installed such that the manufacturer's trademark and material grade marking is visible, allowing easy comparison to the materials selected and documented in the Emerson/Fisher serial card provided with this product.

⚠ WARNING

Personal injury or damage to equipment could occur if improper stud and nut materials or parts are used. Do not operate or assemble this product with stud(s) and nut(s) that are not approved by Emerson/Fisher engineering and/or listed on the serial card provided with this product. Use of unapproved materials and parts could lead to stresses exceeding the design or code limits intended for this particular service. Install studs with the material grade and manufacturer's identification mark visible. Contact your [Emerson sales office](#) or Local Business Partner immediately if a discrepancy between actual parts and approved parts is suspected.

5. Place the bonnet (key 12, figure 13) on the valve body. Lubricate the threads of the studs (key 28) and the faces of the hex nuts (key 27) with anti-seize lubricant (key 18) (not necessary if new factory prelubricated hex nuts are used). Replace the washers and hex nuts but do not tighten them. Torque the nuts in a crisscross pattern to no more than 1/4 of the nominal torque value specified in table 6. When all nuts are tightened to that torque value, increase the torque by 1/4 of the specified nominal torque and repeat the crisscross pattern. Repeat this procedure until all nuts are tightened to the specified nominal value. Apply the final torque value again and, if any nut still turns, tighten every nut again.
6. After system flushing is completed, remove the bonnet (key 12) and bonnet gaskets (key 6), upper flushing plate (key 30), cage retainer (key 5), lower flushing plate (key 31), and cage gasket (key 7).
7. Assemble the valve as described in the Trim Replacement procedure.

Parts Ordering

Each valve body-bonnet assembly is assigned a serial number, which can be found on the valve body. This same number also appears on the actuator nameplate when the valve is shipped from the factory as part of a control valve assembly. Refer to the number when contacting your [Emerson sales office](#) or Local Business Partner for technical assistance or when ordering replacement parts.

⚠ WARNING

Use only genuine Fisher replacement parts. Components that are not supplied by Emerson Automation Solutions should not, under any circumstances, be used in any Fisher valve, because they may void your warranty, might adversely affect the performance of the valve, and could cause personal injury and property damage.

When ordering replacement parts, also be sure to include the 11-character part number from the following parts kits or parts list information.

Parts Kits

Standard Packing Repair Kits (Non Live-Loaded)

Stem Diameter, mm (Inches) Yoke Boss Diameter, mm (Inches)	19.1 (3/4) 90 (3-9/16)	25.4 (1) 127 (5)	31.8 (1-1/4) 127 (5, 5H)
PTFE (Contains keys 22, 24, 25, 26, 27)	RPACKX00032	RPACKX00342	RPACKX00352
Double PTFE (Contains keys 22, 24, 26, 27)	RPACKX00062	RPACKX00362	RPACKX00372
Single Graphite Ribbon/Filament (Contains keys 23 [ribbon ring], 23 [filament ring], 24, and 26)	RPACKX00122	---	---
Single Graphite Ribbon/Filament (Contains keys 23 [ribbon ring], 23 [filament ring], and 26)	---	RPACKX00532	RPACKX00542
Single Graphite Ribbon/Filament (Contains keys 23 [ribbon ring], 23 [filament ring])	RPACKX00152	---	---

ENVIRO-SEAL™ Packing Retrofit Kits

Retrofit kits include parts to convert valves with existing standard bonnets to the ENVIRO-SEAL packing box construction.

Refer to figure 10 for key numbers for PTFE packing, to figure 11 for key numbers for Graphite ULF packing, and to figure 12 for key numbers for duplex packing.

PTFE kits include keys 200, 201, 211, 212, 214, 215, 217, 218, tag, and cable tie. Graphite ULF kits include keys 200, 201, 207, 208, 209, 210, 211, 212, 214, 216, 217, tag, and cable tie. Duplex kits include keys 200, 201, 207, 209, 211, 212, 214, 215, 216, 217, tag, and cable tie.

Stems and packing box constructions that do not meet Fisher stem finish specifications, dimensional tolerances, and design specifications may adversely alter the performance of this packing kit.

For part numbers of individual components in the ENVIRO-SEAL packing kits, refer to instruction manual ENVIRO-SEAL Packing System for Sliding-Stem Valves, [D101642X012](#).

ENVIRO-SEAL Packing Retrofit Kits

PACKING MATERIAL	STEM DIAMETER AND YOKE BOSS DIAMETER, mm (INCH)		
	19.1 (3/4) 90 (3-9/16)	25.4 (1) 127 (5)	31.8 (1-1/4) 127 (5, 5H)
Double PTFE	RPACKXRT032	RPACKXRT042	RPACKXRT052
Graphite ULF	RPACKXRT282	RPACKXRT292	RPACKXRT302
Duplex	RPACKXRT232	RPACKXRT242	RPACKXRT252

ENVIRO-SEAL Packing Repair Kits

Repair kits include parts to replace the “soft” packing materials in valves that already have ENVIRO-SEAL packing arrangements installed or in valves that have been upgraded with ENVIRO-SEAL retrofit kits.

Refer to figure 10 for key numbers for PTFE packing, to figure 11 for key numbers for Graphite ULF packing, and to figure 12 for key numbers for duplex packing.

PTFE repair kits include keys 214, 215, and 218. Graphite ULF repair kits include keys 207, 208, 209, 210, and 214. Duplex repair kits include keys 207, 209, 214, and 215.

Stems and packing box constructions that do not meet Fisher stem finish specifications, dimensional tolerances, and design specifications may adversely alter the performance of this packing kit.

For part numbers of individual components in the ENVIRO-SEAL packing kits, refer to instruction manual ENVIRO-SEAL Packing System for Sliding-Stem Valves, [D101642X012](#).

ENVIRO-SEAL Packing Repair Kits

Stem Diameter, mm (Inches) Yoke Boss Diameter, mm (Inches)	19.1 (3/4) 90 (3-9/16)	25.4 (1) 127 (5)	31.8 (1-1/4) 127 (5, 5H)
Double PTFE (Contains keys 214, 215, & 218)	RPACKX00212	RPACKX00222	RPACKX00232
Graphite ULF (Contains keys 207, 208, 209, 210, and 214)	RPACKX00612	RPACKX00622	RPACKX00632
Duplex (Contains keys 207, 209, 214, and 215)	RPACKX00312	RPACKX00322	RPACKX00332

Figure 10. Typical ENVIRO-SEAL Packing System with PTFE Packing

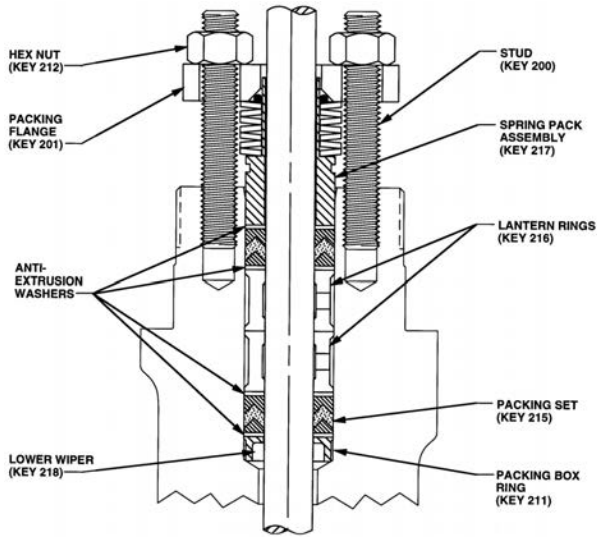

A6297-1

Figure 12. Typical ENVIRO-SEAL Packing System with Duplex Packing

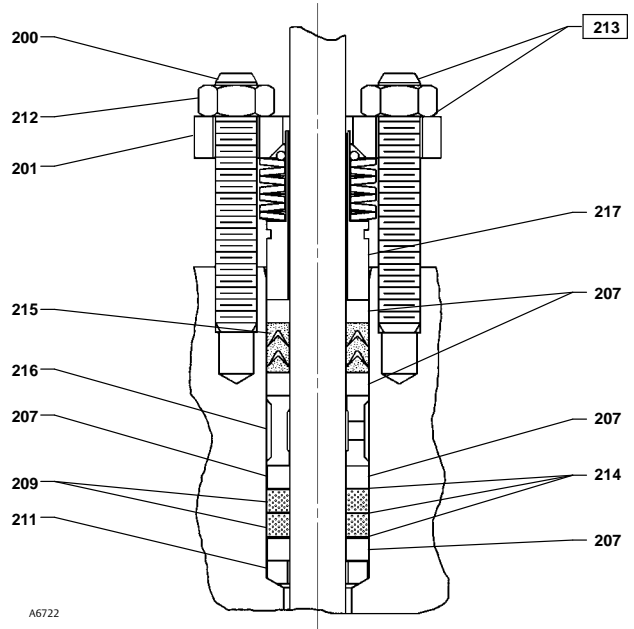

A6722

Figure 11. Typical ENVIRO-SEAL Packing System with Graphite ULF Packing

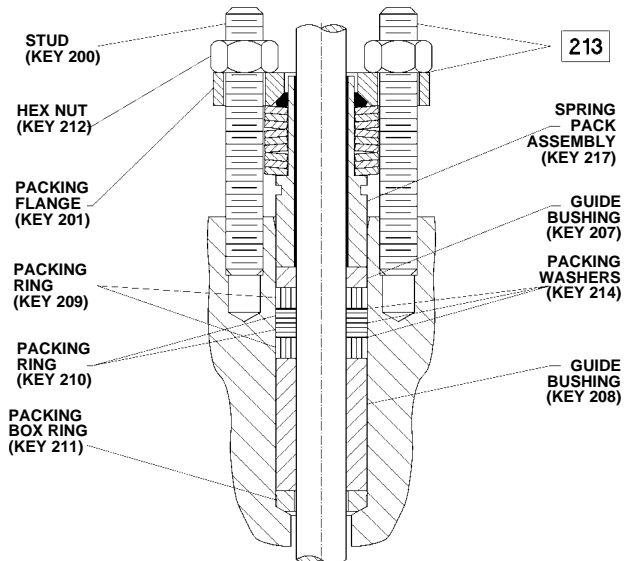

3984612/A

Parts List

Note

Part numbers are shown for recommended spares only. For part numbers not shown, contact your [Emerson sales office](#) or Local Business Partner.

Key	Description	Part Number
	Flushing Trim Kit (includes keys, 6, 7, 30, & 31)	
	NPS 2	RCAV4X00022
	NPS 4	RCAV4X00042
	NPS 6	RCAV4X00062
	Nameplate Wire (use when actuator is not furnished) (not shown)	
	Drive Screw, stainless steel (4 req'd)	
	Cage Retainer Assembly Tool, S41600 (heat-treated 416 stainless steel, not shown)	
	NPS 2	26A5496X012
	NPS 4	28A2828X012
	NPS 6	25A4066X012
1	Valve Body	
	If you need a valve body as a replacement part, order by valve size, serial number, and desired material.	
2*	Lower Cage Assembly, HT	
	S17400 / S31600	
	Standard Hi Temp	
	NPS 2	31B9641X012
	NPS 4	31B7696X012
	NPS 6	31B9652X012
	S17400 / S31600	
	Characterized Hi Temp	
	NPS 2	31B9641X022
	NPS 4	31B7696X022
	NPS 6	31B9652X022
	S17400 H1075	
	Standard Lo Temp	
	NPS 2	31B9642X012
	NPS 3	37B9440X012
	NPS 4	31B9649X012

Key	Description	Part Number
	NPS 6	31B9653X012
	Characterized Lo Temp	
	NPS 2	31B9642X032
	NPS 3	37B9440X022
	NPS 4	31B9649X022
	NPS 6	31B9653X022
3*	Upper Cage, HT	
	S17400	
	Seal Ring Construction	
	NPS 2	48A2824X012
	NPS 3	47B9383X012
	NPS 4	48A1974X012
	Stem Balanced Construction	
	NPS 2	48A2820X012
	NPS 4	48A1970X012
	Seal Ring/Piston Ring Construction	
	NPS 6	38A1946X012
4*	Valve Plug & Stem Assembly	See following tables
5*	Cage Retainer, heat-treated, tables chrome S17400	
	NPS 2	26A5302X042
	NPS 4	28A1966X012
	NPS 6	38A1955X012
6*	Bonnet Gasket, silver pl N04400 (2 req'd)	
	NPS 2	26A5320X012
	NPS 3	26A5322X012
	NPS 4	28A1981X012
	NPS 6	25A3965X012
7*	Cage Gasket, S31600 / Graphite	
	NPS 2	11B4909X012
	NPS 3	17B9382X012
	NPS 4	11B2024X012
	NPS 6	11B2026X012
8*	Valve Plug Seal Ring, graphite filled PTFE cover w/R30003 spring (for seal ring construction)	
	NPS 2	13A8521X082
	NPS 3	16A1968X032
	NPS 4	13A8534X062
	NPS 6	10A4223X112
9	Valve Plug Back Up Ring	
10*	Retaining Ring, stainless steel (for seal ring construction)	
	NPS 2	13A8519X012
	NPS 3	16A1969X012
	NPS 4	13A8532X012
	NPS 6	10A4225X012

Figure 13. Fisher CAV4 Control Valve with Cavitol IV Trim

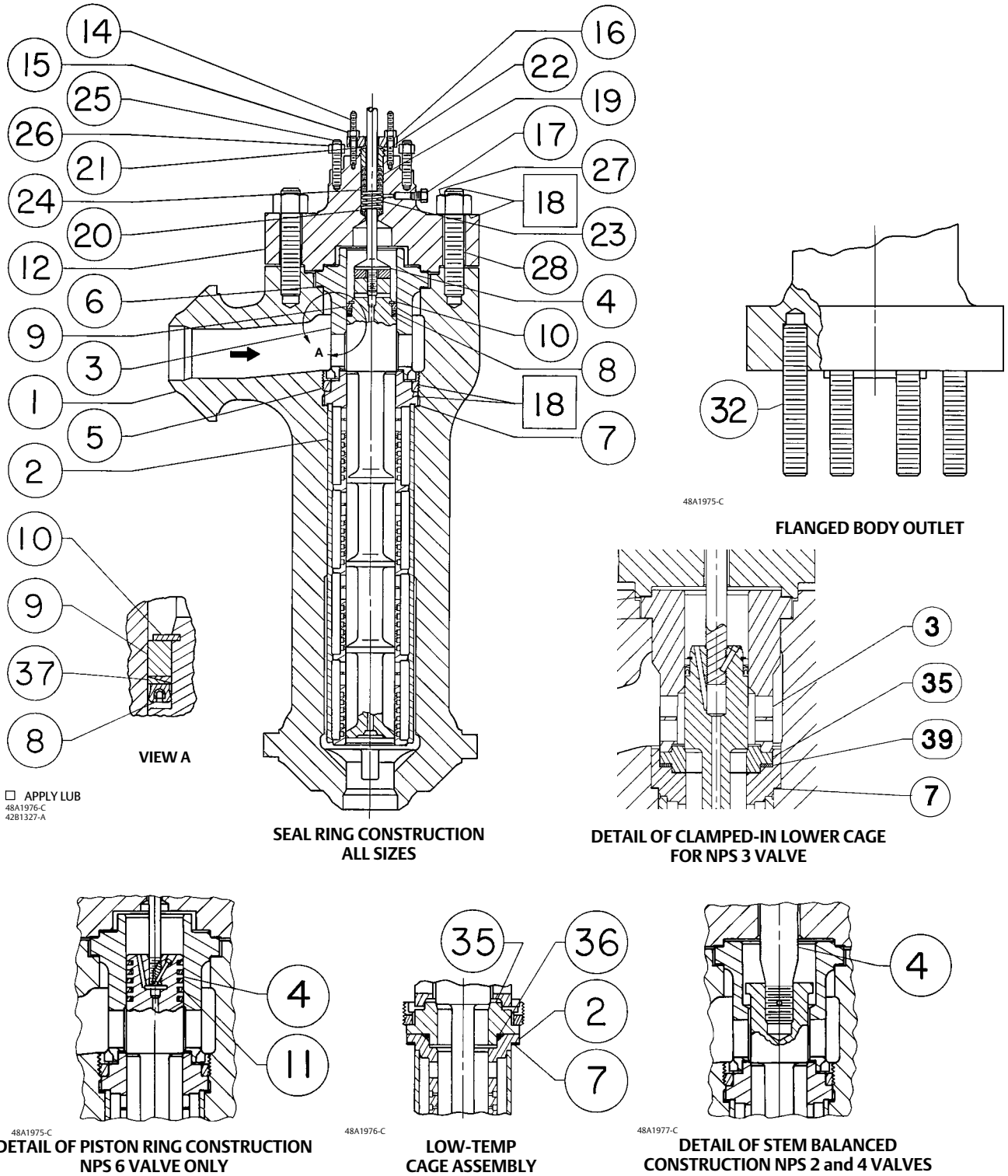
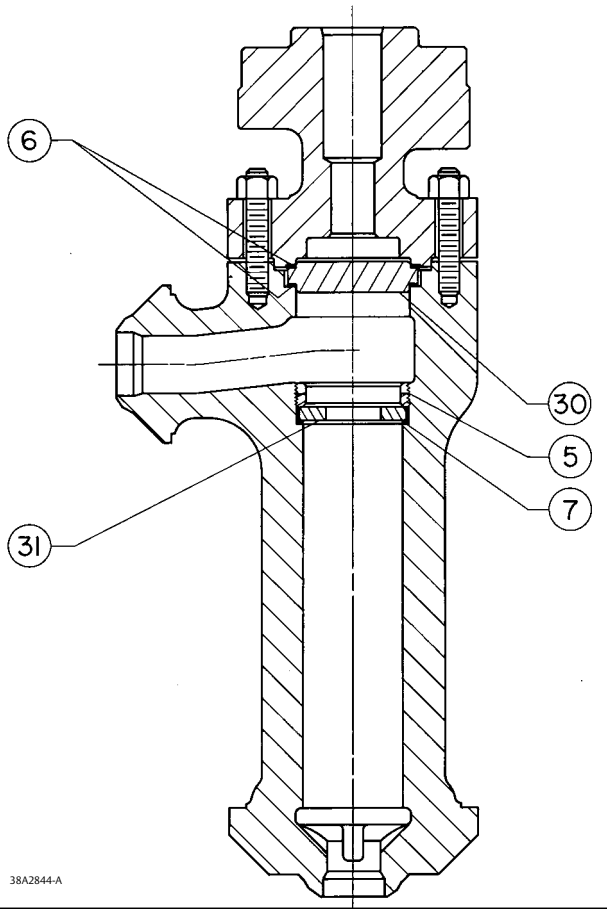

Figure 14. Optional Flushing Trim



Key	Description	Part Number
11*	Piston Ring, graphite (5 req'd) for piston ring construction	1U2392X0012
12	Bonnet If you need a bonnet as a replacement part, order by valve size and stem diameter, serial number, and desired material.	
13*	Packing Ring	See following table
14	Packing Flange Stud Bolt, (2 req'd)	
15	Packing Flange Hex Nut [2 req'd, except 4 req'd on 178 mm (7 inch) yoke boss]	
16	Packing Flange	
17	Pipe Plug	
18	Anti-Seize Lubricant, (not furnished with the valve)	

Key	Description	Part Number
19*	Packing Set	See following table
20*	Packing Box Ring	See following table
21*	Upper Wiper	See following table
22	Packing Follower	See following table
23	Packing Spring	See following table
23	Lantern Ring	See following table
24	Special Washer	See following table
25	Stud Bolt, steel (8 req'd)	
26	Yoke Locknut (not shown)	
26	Hex Nut, steel (8 req'd)	
27	Hex Nut, steel (SA-194-2H) NPS 2 (8 req'd) NPS 3 (8 req'd) NPS 4 (8 req'd) NPS 6 (12 req'd)	
28	Stud Bolt, steel (SA-193-B7) NPS 2 (8 req'd) NPS 3 (8 req'd) NPS 4 (8 req'd) NPS 6 (12 req'd)	
29*	Packing Rings	See following table
30	Upper Flushing Plate	
31	Lower Flushing Plate	
32	Line Flange Studs (8 req'd)	
33	Yoke Locknut, steel [for 19.1 mm (3/4 inch) stem only] (not shown)	
35*	Seat Ring S31600 NPS 3	27B6291X012
35*	Seat Ring, HT S17400 / S31600 NPS 2 NPS 4 NPS 6	21B9640X032 21B9647X022 31B9650X022
36*	O-Ring, EPT NPS 2 NPS 4 NPS 6	1K1365X0082 1N9563X0032 12A3793X012
37*	Anti-Extrusion Ring, PEEK/Carbon NPS 2 NPS 3 NPS 4 NPS 6	21B9339X012 27B1174X012 21B2025X012 21B9341X012
39	Spiral Wound Gasket	

TSO (Tight Shutoff) Trim Parts

2*	Cage Assembly	See following table
5*	Cage Retainer	See following table
3*	Upper Cage	See following table
35*	Seat Ring	See following table
4*	Plug/Stem Assembly	See following table
8*	Seal Ring	See following table
37*	Anti-Extrusion Ring	See following table
9*	Back Up Ring	See following table
10*	Retaining Ring	See following table

*Recommended spare parts

Key 4* Valve Plug & Stem Assembly

VALVE SIZE, NPS	VALVE STEM DIAMETER		VALVE PLUG TRAVEL		ACTUATORS ⁽¹⁾	VALVE PLUG MATERIAL ⁽²⁾	
	mm	Inch	mm	Inch		Heat Treated S44004	S31600 w/CoCr-A Seat/Guide
Seal Ring Construction							
2	19.1	3/4	38	1.5	Group 1	42B0593X022	42B0594X022
3	19.1	3/4	51	2	Group 1	47B9380X022	---
4	19.1	3/4	64	2.5	Groups 1, 402 & 403	41B8678X022	42B0597X022
	25.4	1	64	2.5	Group 100	42B0595X022	42B0598X022
	25.4	1	64	2.5	Groups 101 & 405	42B0595X032	42B0598X032
	25.4	1	64	2.5	Group 406	42B0595X042	42B0598X042
6	31.8	1-1/4	102	4	Group 407	42B0600X022	42B0601X022
			102	4	Groups 408 & 409	42B0600X032	42B0601X032
Stem-Balanced Construction							
2	38.1	1-1/2	38	1.5	Group 100	38A2821X022	---
					Group 101	38A2821X032	---
4	69.9	2-3/4	64	2.5	Type 657 Size 80	38A1967X022	---
			64	2.5	Type 470 Series Size 130 & Group 408	38A1967X032	---
Piston Ring Construction							
6	31.8	1-1/4	102	4	Group 407 Groups 408 & 409	42B0602X022 42B0602X032	--- ---

1. See Actuator Groups (by Type Number) table for appropriate actuator group.
 2. Valve stem material is S31600, except for S17400 19.1 mm (3/4 inch) stem in the NPS 4 valve body.

Keys 2*, 5*, 3*, 35*, 4*, 8*, 37*, 9*, and 10* TSO Trim Parts for Fisher CAV4 Valves⁽¹⁾

VALVE SIZE, NPS	PORT, INCH	TRAVEL, INCH	STEM DIAMETER		ACTUATOR GROUP	CHARACTERISTIC	KEY 2	KEY 5	KEY 3	KEY 35	KEY 4
			mm	Inch			Cage Assembly	Cage Retainer	Upper Cage	Seat Ring	Plug/Stem Assembly
2	1.5	1.5	19.1	3/4	1	Std Characterized	31B9642X012 31B9642X032	26A5302X012	48B0292X012	38B0293X012	38B0289X012
3	2.1875	2	19.1	3/4	1	Std Characterized	37B9440X012 37B9440X022	---	38B1295X012	38B1296X012	38B0296X012
4	2.6875	2.5	19.1	3/4	1, 402, 403	Std Characterized	31B9649X012 31B9649X022	28A1966X012	44B1770X012	34B1773X012	38B1301X012
					100	Std Characterized	31B9649X012 31B9649X022				38B0288X012
			25.4	1	101, 405	Std Characterized	31B9649X012 31B9649X022				38B0288X022
					406	Std Characterized	31B9649X012 31B9649X022				38B0288X032
VALVE SIZE, NPS	PORT, INCH	TRAVEL, INCH	STEM DIAMETER		ACTUATOR GROUP	CHARACTERISTIC	KEY 8	KEY 37	KEY 9	KEY 10	
			mm	Inch			Seal Ring	Anti-Extrusion Ring	Back Up Ring	Retaining Ring	
2	1.5	1.5	19.1	3/4	1	Std Characterized	13A8521X092	21B9339X012	11B9300X022	13A8519X012	
3	2.1875	2	19.1	3/4	1	Std Characterized	16A1968X052	27B1174X012	16A1967X022	16A1969X012	
4	2.6875	2.5	19.1	3/4	1, 402, 403	Std Characterized	13A8534X072	21B2025X012	11B8676X012	13A8532X012	
					100	Std Characterized					
			25.4	1	101, 405	Std Characterized					
					406	Std Characterized					

1. Trim 810.

Packing Set / Packing Parts

DESCRIPTION		KEY	STEM DIAMETER, mm (INCH)				
			19.1 (3/4)	25.4 (1)	31.8 (1-1/4)	38.1 (1-1/2)	69.9 (2-3/4)
Single PTFE V-Ring Packing	Packing set		1R290401012	1R290601012	1R290801012	---	---
	Packing ring ⁽¹⁾ , PTFE (3 req'd)	19*	1C752801012	1C752901012	1D387601012	---	---
	Lower wiper ⁽¹⁾ , PTFE		1J872306992	1J872406992	1J872506992	---	---
	Male adaptor ⁽¹⁾ , PTFE		1F124601012	1H982501012	1H995801012	---	---
	Female adaptor ⁽¹⁾ , PTFE		1F124201012	1H982401012	1H995701012	---	---
Single PTFE V-Ring Packing Parts	Packing spring, S31600	23	1F125637012	1D582937012	1D387437012	---	---
	Special washer, S31600	24	1F125036042	1H982236042	1H995936042	---	---
Double PTFE-composition Packing Parts	Packing ring, PTFE-composition (8 req'd)	19*	1E319101042	1D7518X0012	1D7520X0012	---	---
	Lantern ring, stainless steel	23	0N028435072	0U099735072	0W087135072	---	---
Double Graphite Ribbon/Filament Packing Parts	Packing ring ⁽²⁾ , graphite ribbon (3 req'd)	13*	---	---	1V5666X0022	18A2830X012	14A7915X012
	Lantern ring, stainless steel	23	---	---	0W087135072	18A2825X012	24A7912X012
	Packing ring, graphite filament	29*	---	---	1D7520X0162 (5 req'd)	14A1933X022 (4 req'd)	14A7914X012 (4 req'd)
Common Parts	Packing box ring S31600	20*	1J873335072	1J873435072	1J873535072	16A6087X012	14A7913X012
	Upper wiper, felt (not req'd for graphite ribbon/filament packing)	21*	1J872806332	1J872906332	1J873006332	---	---
	Packing follower S31600	22	1E944735072	1H982335072	1H998435072	12A8925X012	24A7911X012
	Warning Tag	---					11B9513X012

1. Included in packing set.
2. Comes with washer.

Actuator Groups (by Type Number)

Group 1 90.5 mm (3-9/16 Inch) Yoke Boss	Group 405 127 mm (5 Inch) Yoke Boss
472 & 473 585C—50.8 mm (2 inch) maximum travel 657 & 667—76.2 mm (3 inch) maximum travel 1008—Except with 50.8 mm (2 inch) travel	657 MO 657-4 MO
Group 100 127 mm (5 Inch) Yoke Boss	Group 406 127 mm (5 Inch) Yoke Boss
472 473 474 476 585C 657 1008	667 MO 667-4 MO
Group 101 127 mm (5 Inch) Yoke Boss	Group 407 127 mm (5 Inch) Yoke Boss
667	474 585C 657
Group 401 90.5 mm (3-9/16 Inch) Yoke Boss	Group 408 127 mm (5H) & 178 mm (7 Inch) Yoke Boss
657 657 MO 657-4 657-4 MO 667 667 MO	657 Size 100 685 1008
	Group 409 127 mm (5H) & 178 mm (7 Inch) Yoke Boss
	667 Size 100

Neither Emerson, Emerson Automation Solutions, nor any of their affiliated entities assumes responsibility for the selection, use or maintenance of any product. Responsibility for proper selection, use, and maintenance of any product remains solely with the purchaser and end user.

Fisher, Cavitrol, and ENVIRO-SEAL are marks owned by one of the companies in the Emerson Automation Solutions business unit of Emerson Electric Co. Emerson Automation Solutions, Emerson, and the Emerson logo are trademarks and service marks of Emerson Electric Co. All other marks are the property of their respective owners.

The contents of this publication are presented for informational purposes only, and while every effort has been made to ensure their accuracy, they are not to be construed as warranties or guarantees, express or implied, regarding the products or services described herein or their use or applicability. All sales are governed by our terms and conditions, which are available upon request. We reserve the right to modify or improve the designs or specifications of such products at any time without notice.

Emerson Automation Solutions
Marshalltown, Iowa 50158 USA
Sorocaba, 18087 Brazil
Cernay 68700 France
Dubai, United Arab Emirates
Singapore 128461 Singapore

www.Fisher.com

