

## In-Line Deflagration Flame Arrester

concentric design,  
bidirectional

PROTEGO® FA-I-PTFE

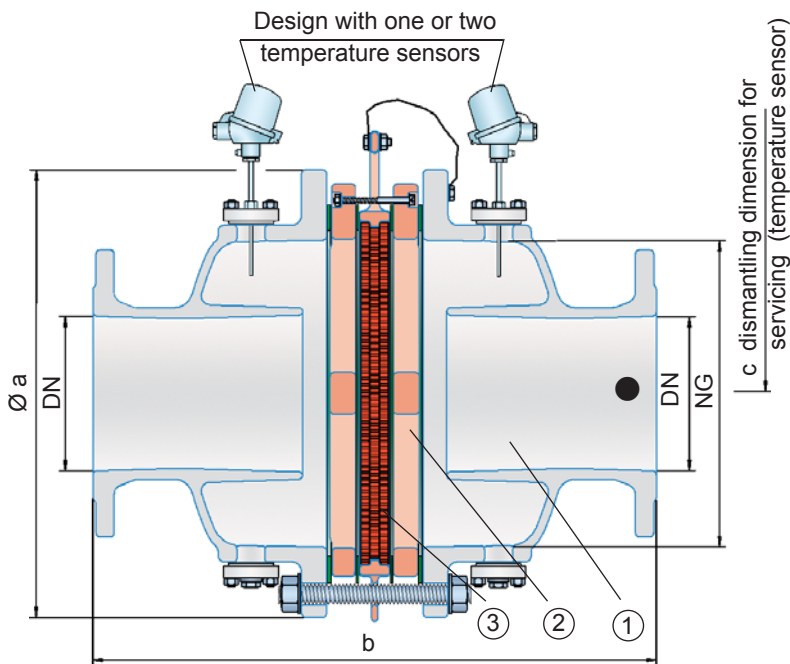

● Connection to the protected side  
(only for type FA-I-PTFE-T-...)

### Special Features and Advantages

- build up of adhesive materials is prevented by the smooth surfaces
- application especially for corrosive and polymerizing media
- minimum number of FLAMEFILTER® discs due to patented design
- service-friendly design
- the modular design enables each individual FLAMEFILTER® to be replaced
- bidirectional operation as well as any direction of flow
- installation of temperature sensors is possible
- less soiling of the device lowers service, operating and life-cycle costs
- minimum pressure loss and associated low operating and life-cycle costs

### Function and Description

The in-line deflagration flame arresters type PROTEGO® FA-I-PTFE are the latest generation of flame arresters and are distinguished by their unique resistance to adhesive and corrosive media. The use of fluoroplastics as a high-tech housing coating and as solid material for the flame arrester element is unique throughout the world.

When installing the deflagration flame arrester make sure that the distance between potential ignition sources and the location of the installed device, the L/D ratio (pipe length/pipe diameter), does not exceed the value of 50.

The deflagration flame arrester is symmetrical and offers bidirectional flame transmission protection. The arrester essentially consists of two coated housing parts (1) and the PROTEGO® flame arrester unit (2) in the center. The PROTEGO® flame arrester unit is modular and consists of several FLAMEFILTER® discs (3) and spacers firmly held in a FLAMEFILTER® cage. The number of PTFE-FLAMEFILTER® discs and their gap size depends on the arrester's conditions of use.

The deflagration flame arrester PROTEGO® FA-I-PTFE can be used for explosion group IIA (NFPA group D). The standard design is approved at an operating temperature up to +60°C / 140°F. The maximum allowable operating pressure depends on nominal diameter (DN) and nominal size (NG) and amounts to a maximum of 1.6 bar / 23.2 psi absolute (for DN 100 / 4" and DN 150 / 6" see table 3).

Type-approved according to ATEX Directive 94/9/EC and EN ISO 16852 as well as other international standards.

### Design Types and Specifications

There are three different designs available:

Basic in-line deflagration flame arrester **FA-I-PTFE - [ ]**

In-line deflagration flame arrester with integrated temperature sensor\* as additional protection against short time burning from one side **FA-I-PTFE - [ T ]**

In-line deflagration flame arrester with two integrated temperature sensors\* for additional protection against short time burning from both sides **FA-I-PTFE - [ TB ]**

Additional special flame arresters upon request

\*Resistance thermometer for device group II, category (1) 2 (GII cat. (1) 2)

**Table 1: Dimensions**

Dimensions in mm / inches

To select series and nominal size (DN) - nominal width (NG) combination, please use the flow capacity chart on the following page

DN	50 / 2"	80 / 3"	100 / 4"	150 / 6"
NG	150 / 6"	150 / 6"	200 / 8"	300 / 12"
a	287 / 11.30	287 / 11.30	342 / 13.46	447 / 17.60
b	380 / 14.96	380 / 14.96	468 / 18.43	612 / 24.09
c	430 / 16.93	430 / 16.93	480 / 18.90	530 / 20.87

**Table 2: Selection of the explosion group**

MESG	Expl. Gr. (IEC/CEN)	Gas Group (NEC)	Special approvals upon request
> 0.90 mm	IIA	D	

**Table 3: Selection of max. operating pressure**

DN	50 / 2"	80 / 3"	100 / 4"	150 / 6"
NG	150 / 6"	150 / 6"	200 / 8"	300 / 12"
P <sub>max</sub>	1.6 / 23.2	1.6 / 23.2	1.2 / 17.4	1.2 / 17.4

P<sub>max</sub> = in bar / psi absolut, higher operating pressure upon request

**Table 4: Specification of max. operating temperature**

≤ 60°C / 140°F	higher operating temperatures upon request
T60	Tmaximum allowable operating temperature in °C

**Table 5: Material for housing**

Design	A
Housing	Steel with an ECTFE coating
Gasket	PTFE
Flame arrester unit	A, B, C

Special materials upon request

**Table 6: Material combinations of the flame arrester unit**

Design	A	B	C
FLAMEFILTER® cage	Steel with an ECTFE coating	Hastelloy	Stainless Steel
Spider rings	Steel with an ECTFE coating	Hastelloy	Stainless Steel
FLAMEFILTER® *	PTFE*	PTFE*	PTFE*
Spacer	PEEK / ETFE / FEP	PEEK / ETFE / FEP	PEEK / ETFE / FEP

Special materials upon request

\* electrically conductive

**Table 7: Flange connection type**

EN 1092-1, Form B1 or DIN 2501, Form C, PN 16	EN or DIN	other types upon request
ANSI 150 lbs RFSF	ANSI	



for safety and environment

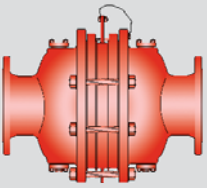

# In-Line Deflagration Flame Arrester

concentric design,  
bidirectional

**PROTEGO® FA-I-PTFE**

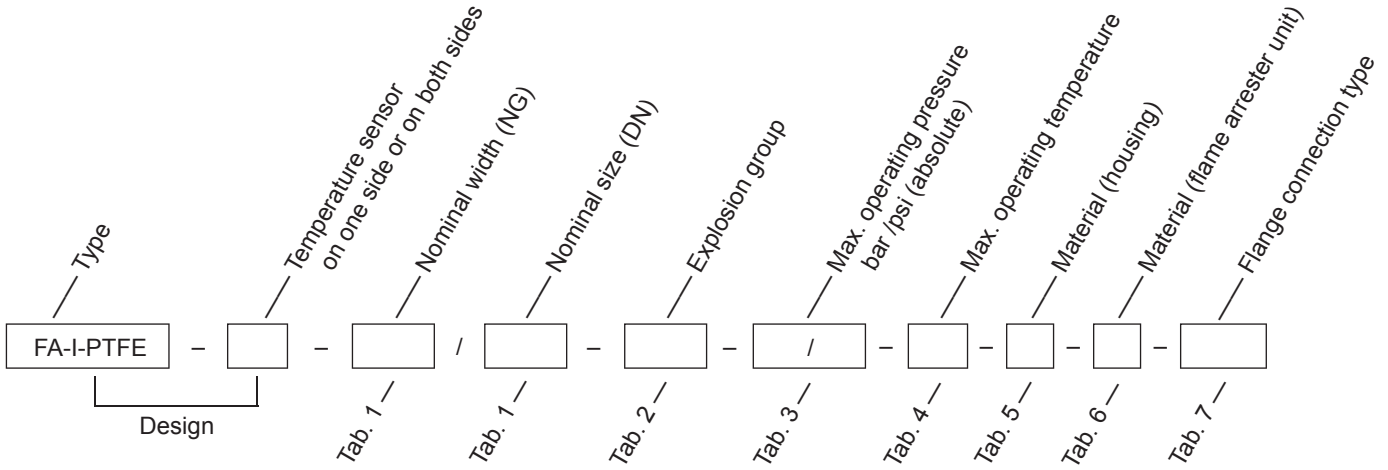

## Order example

FA-I-PTFE - TB - 300 / 150 - IIA - P1.2/- - T60 - A - A - DIN

Materials and chemical resistance: See Vol. 1 "Technical Fundamentals"

## Flow Capacity Chart

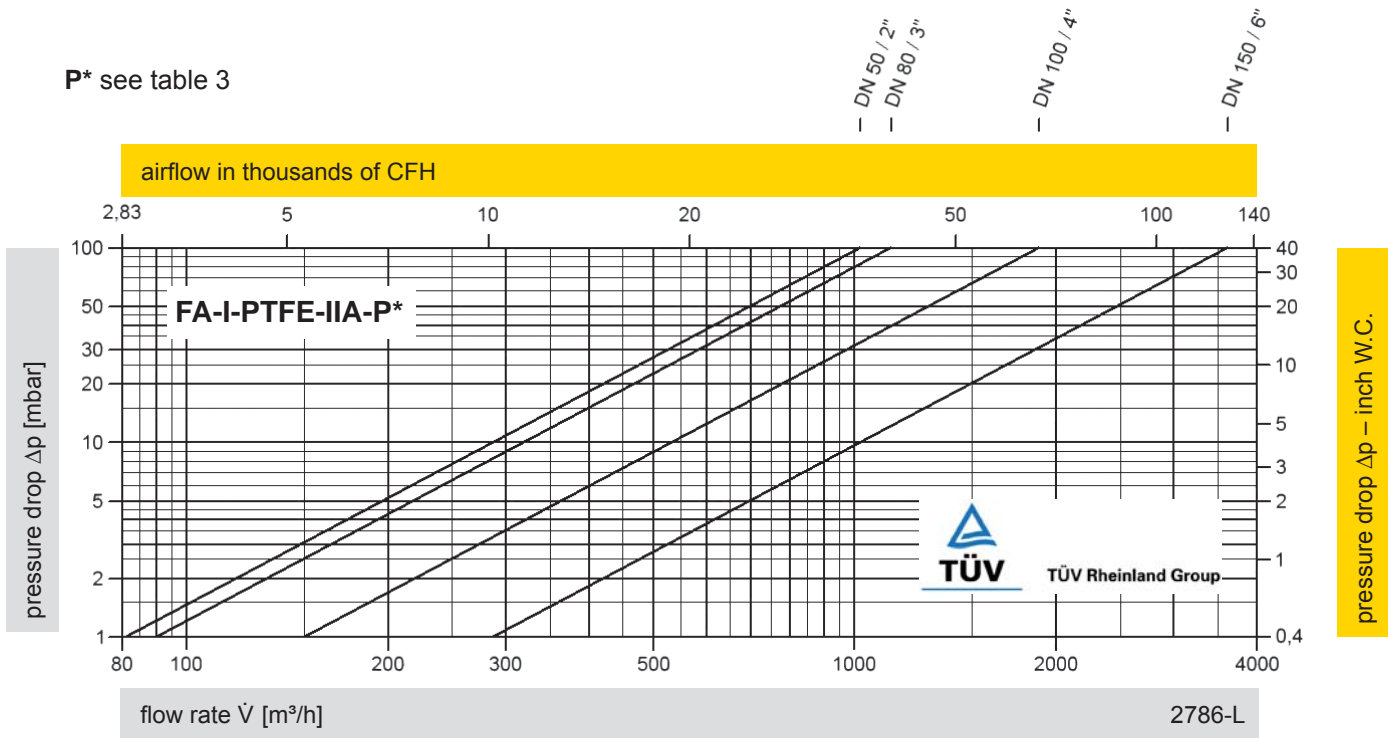

The flow capacity chart has been determined with a calibrated and TÜV certified flow capacity test rig.  
Volume flow  $\dot{V}$  in [m<sup>3</sup>/h] and CFH refer to the standard reference conditions of air ISO 6358 (20°C, 1bar).  
Conversion to other densities and temperatures refer to Vol. 1: "Technical Fundamentals".