

Rosemount™ 3144P Temperature Transmitters

with FOUNDATION™ Fieldbus Protocol



Contents

About this guide.....	3
Mount the transmitter.....	5
Wire and apply power.....	7
Verify tagging.....	12
Product certifications.....	16

1 About this guide

This guide provides basic guidelines for installing the Rosemount 3144P Transmitter. It does not provide instructions for detailed configuration, diagnostics, maintenance, service, troubleshooting, Explosion-proof, Flameproof, or intrinsically safe (I.S.) installations. Refer to the Rosemount 3144P Transmitter [Reference Manual](#) for more instructions. The manual and this guide are also available electronically on Emerson.com/Rosemount.

⚠ WARNING

Explosions

Explosions could result in death or serious injury.

Installation of device in an explosive environment must be in accordance with appropriate local, national, and international standards, codes, and practices.

Review the Product Certifications section of this document for any restrictions associated with a safe installation.

In an Explosion-proof/Flameproof installation, do not remove the transmitter covers when power is applied to the unit.

Process leaks

Process leaks may cause harm or result in death.

Install and tighten thermowells and sensors before applying pressure. Do not remove the thermowell while in operation.

Conduit/cable entries

The conduit/cable entries in the transmitter housing use a ½–14 NPT thread form.

When installing in a hazardous location, use only appropriately listed or Ex certified plugs, glands, or adapters in cable/conduit entries.

Electrical shock

Electrical shock can result in death or serious injury.

Avoid contact with the leads and terminals. High voltage that may be present on leads could cause electrical shock.

⚠ WARNING

Physical access

Unauthorized personnel may potentially cause significant damage to and/or misconfiguration of end users' equipment. This could be intentional or unintentional and needs to be protected against.

Physical security is an important part of any security program and fundamental to protecting your system. Restrict physical access by unauthorized personnel to protect end users' assets. This is true for all systems used within the facility.

2 Mount the transmitter

Mount the transmitter at a high point in the conduit run to prevent moisture from draining into the transmitter housing.

2.1 Typical North American installation

Figure 2-1: Typical Direct-Mounted Configuration

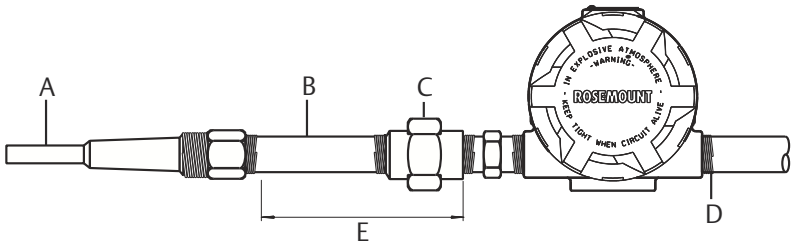

- A. Thermowell
- B. Extension (nipple)
- C. Union or coupling
- D. Conduit for field wiring (dc power)
- E. Extension fitting length

Procedure

1. Mount the thermowell to the process container wall.
2. Install and tighten thermowells.
3. Perform a leak check.
4. Attach any necessary unions, couplings, and extension fittings. Seal the fitting threads with an approved thread sealant, such as silicone or PTFE tape (if required).
5. Screw the sensor into the thermowell or directly into the process (depending on installation requirements).
6. Verify all sealing requirements.
7. Attach the transmitter to the thermowell/sensor assembly. Seal all threads with an approved thread sealant, such as silicone or PTFE tape (if required).
8. Install field wiring conduit into the open transmitter conduit entry (for remote mounting) and feed wires into the transmitter housing.
9. Pull the field wiring leads into the terminal side of the housing.
10. Attach the sensor leads to the transmitter sensor terminals.
The wiring diagram is located inside the housing cover.

- Attach and tighten both transmitter covers.

2.2 Typical European installation

Figure 2-2: Typical Remote-Mounted Configuration with Cable Glands

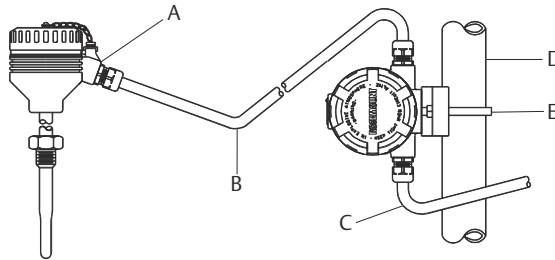

- Cable gland
- Shielded cable from sensor to transmitter
- Shielded cable from transmitter to control room
- 2-in. (50 mm) pipe
- B4 mounting bracket

Procedure

- Mount the thermowell to the process container wall.
- Install and tighten thermowells.
- Perform a leak check.
- Attach a connection head to the thermowell.
- Insert sensor into the thermowell and wire the sensor to the connection head.
The wiring diagram is located inside the connection head.
- Mount the transmitter to a 2-in. (50 mm) pipe or a panel using one of the optional mounting brackets.
- Attach cable glands to the shielded cable running from the connection head to the transmitter conduit entry.
- Run the shielded cable from the opposite conduit entry on the transmitter back to the control room.
- Insert shielded cable leads through the cable entries into the connection head/transmitter. Connect and tighten cable glands.
- Connect the shielded cable leads to the connection head terminals (located inside the connection head) and to the sensor wiring terminals (located inside the transmitter housing).

3 Wire and apply power

3.1 Wire the transmitter

Table 3-1: Single Sensor

2-wire RTD and ohms	3-wire RTD and ohms ⁽¹⁾	4-wire RTD and ohms	T/Cs and millivolts	RTD with compensation loop ⁽²⁾

- (1) Emerson provides 4-wire sensors for all single-element RTDs. You can use these RTDs in 3-wire configurations by leaving the unneeded leads disconnected and insulated with electrical tape.
- (2) Transmitter must be configured for a 3-wire RTD in order to recognize an RTD with a compensation loop.

Table 3-2: Dual Sensor

Emerson provides 4-wire sensors for all single-element RTDs. To use these RTDs in three-wire configurations, leave the unneeded leads disconnected and insulated with electrical tape.

ΔT /Hot Backup™/ dual sensor with two RTDs	ΔT /Hot Backup/ dual Sensor with two thermocouples	ΔT /Hot Backup/ dual sensor with RTDs/ thermocouples	ΔT /Hot Backup/ dual sensor with RTDs/ thermocouples	ΔT /Hot Backup/ dual sensor with two RTDs with compensation loop

3.2 Power the transmitter

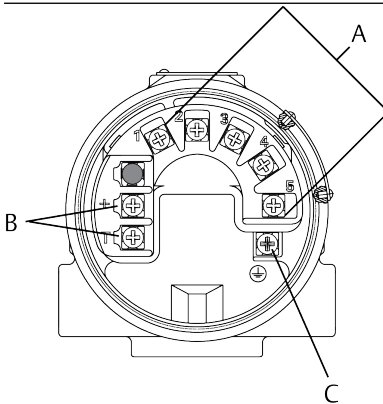

- A. Sensor terminals (1–5)
 - B. Power terminals
 - C. Ground
-

Procedure

1. Remove the terminal block cover.
2. Connect power to the power terminal.
The terminals are polarity insensitive.
3. Tighten the terminal screws.
4. Reattach and tighten the cover.

⚠ WARNING

Enclosure

Enclosure covers must be fully engaged to meet explosion-proof requirements.

5. Apply power.

3.3 Ground the transmitter

3.3.1 Ungrounded thermocouple, mV, and RTD/ohm inputs

Each process installation has different requirements for grounding. Use the grounding options recommended by the facility for the specific sensor type or begin with grounding option 1 (the most common).

Ground the transmitter: option 1

Emerson recommends this option for ungrounded transmitter housing.

Procedure

1. Connect signal wiring shield to the sensor wiring shield.
2. Ensure the two shields are tied together and electrically isolated from the transmitter housing.
3. Ground shield at the power supply end only.
4. Ensure that the sensor shield is electrically isolated from the surrounding grounded fixtures.
5. Connect shields together, electrically isolated from the transmitter.

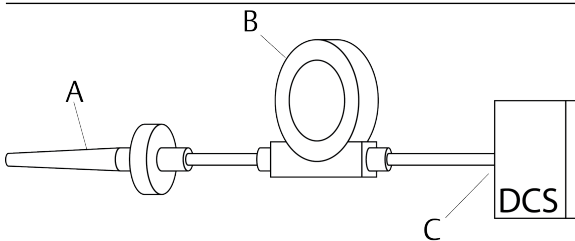

- A. Sensor wire
 B. Transmitter
 C. Shield ground point

Ground the transmitter: option 2

Emerson recommends this method for grounded transmitter housing.

Procedure

1. Connect sensor wiring shield to the transmitter housing.
Do this only if the housing is grounded.
2. Ensure that the sensor is electrically isolated from surrounding fixtures that may be grounded.
3. Ground signal wiring shield at the power supply end.

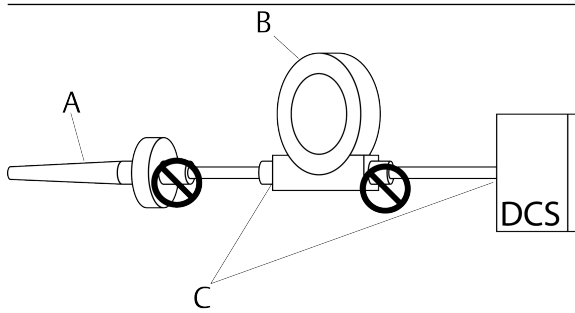

- A. Sensor wire
- B. Transmitter
- C. Shield ground point

Ground the transmitter: option 3

Procedure

1. Ground sensor wiring shield at the sensor, if possible.
2. Ensure the sensor wiring and signal wiring shields are electrically isolated from the transmitter housing and other grounded fixtures.
3. Ground signal wiring shield at the power supply end.

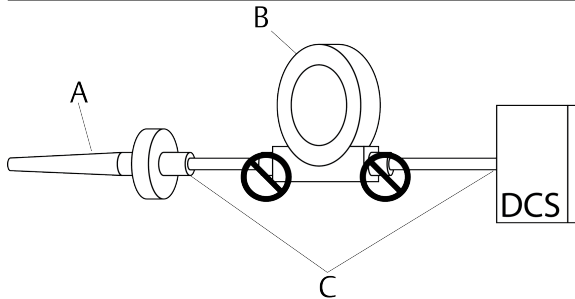

- A. Sensor wire
- B. Transmitter
- C. Shield ground point

3.3.2 Ground thermocouple inputs

Procedure

1. Ground sensor wiring shield at the sensor.

2. Ensure the sensor wiring and signal wiring shields are electrically isolated from the transmitter housing and other grounded fixtures.
3. Ground signal wiring shield at the power supply end.

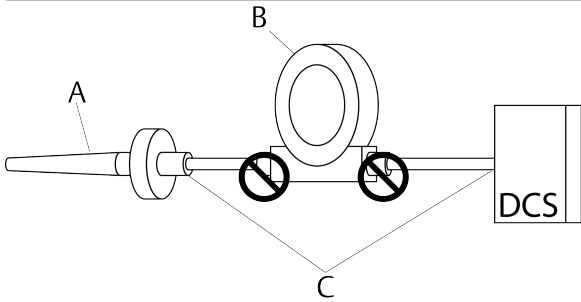

- A. Sensor wire
- B. Transmitter
- C. Shield ground point

4 Verify tagging

4.1 Commissioning (paper) tag

To identify which device is at a particular location use the removable tag provided with the transmitter. Ensure the physical device tag (PD Tag field) is properly entered in both places on the removable commissioning tag and tear off the bottom portion for each transmitter.

COMMISSIONING TAG

Device ID:
0011513051010001440-121698091725

PD Tag:
TT- 101

Revision: 7.2

— — — **Tear Here** — — —

Revision: 7.2

Support files available at
www.rosemount.com

Device Serial
Number:
XXXXXXXXXX

Device ID:
0011513051010001440-1216980917
25

PD Tag:
TT- 101

Note

The device description loaded in the host system must be at the same revision as this device. You can download the device description from Emerson.com/Rosemount.

4.1.1 Verify transmitter configuration

Each FOUNDATION Fieldbus host or configuration tool has a different way of displaying and performing configurations. Some use Device Descriptions (DD) or DD methods for configuration and to display data consistently across platforms. There is no requirement that a host or configuration tool support these features.

The following is the minimum configuration requirement for a temperature measurement. This guide is designed for systems not using DD methods. For a complete list of parameters and configuration information, refer to the Rosemount 3144P Temperature Transmitter [Reference Manual](#).

4.2 Transducer function block

This block contains temperature measurement data for the sensors and the terminal temperature. It also includes information about sensor types, engineering units, damping, and diagnostics.

At a minimum, verify the parameters in [Table 4-1](#).

Table 4-1: Transducer Block Parameters

Parameter	Comments
Typical configuration	
SENSOR_TYPE_X	Example: "Pt 100_A_385 (IEC 751)"
SENSOR_CONNECTIONS_X	Example: "2-wire", "3-wire", "4-wire"
Sensor matching configuration	
SENSOR_TYPE_X	"User Defined, Calvandu"
SENSOR_CONNECTIONS_X	Example: "2-wire", "3-wire", "4-wire"
SENSOR_CAL_METHOD_X	Set to "User Trim Standard"
SPECIAL_SENSOR_A_X	Enter sensor specific coefficients
SPECIAL_SENSOR_B_X	Enter sensor specific coefficients
SPECIAL_SENSOR_C_X	Enter sensor specific coefficients
SPECIAL_SENSOR_R0_X	Enter sensor specific coefficients

4.2.1 Analog Input (AI) function block

The AI block processes field device measurements and makes the outputs available to other function blocks. The output value of the AI block is in engineering units and contains a status indicating the quality of the measurements. Use the channel number to define the variable that the AI block processes.

At a minimum, verify the parameters of each AI block in [Table 4-2](#).

Note

All devices ship with the AI blocks scheduled, meaning the operator does not need to configure the block or he or she uses factory default channels.

Table 4-2: AI Block Parameters

Configure one AI Block for each desired measurement.

Parameter	Comments
CHANNEL	Choices: <ol style="list-style-type: none"> 1. Sensor 1 Temperature 2. Sensor 2 Temperature 3. Differential Temperature 4. Terminal Temperature 5. Sensor 1 Min. Value 6. Sensor 1 Max. Value 7. Sensor 2 Min. Value 8. Sensor 2 Max. Value 9. Differential Min. Value 10. Differential Max. Value 11. Terminal Temp Min. Value 12. Terminal Temp Max. Value 13. Hot Backup
LIN_TYPE	This parameter defines the relationship between the block input and the block output. Since the transmitter does not require linearization, this parameter will always be set to No Linearization. This means that the AI block will only apply scaling, filtering, and limit checking to the input value.
XD_SCALE	Set desired measurement range and units. Units must be one of the following: <ul style="list-style-type: none"> • mV • Ohms • °C • °F • °R • K
OUT_SCALE	For "DIRECT" L_TYPE, set OUT_SCALE to match XD_SCALE
HI_HI_LIM HI_LIM LO_LIM LO_LO_LIM	Process alarms. Must be within the range defined by "OUT_SCALE"

Note

To make changes to the AI block, set the BLOCK_MODE (TARGET) to OOS (out of service). After making the changes, return the BLOCK_MODE TARGET to AUTO.

4.2.2 Set switches

The security and simulate switches are located on the top center of the electronics module.

Note

The factory ships the simulate switch in the "ON" position.

Set the switches with an LCD display

Procedure

1. Set the loop to manual (if applicable) and disconnect the power.
2. Remove the electronics housing cover.
3. Unscrew the LCD display screws and gently slide the meter straight off.
4. Set the alarm and security switches to the desired position.
5. Gently slide the LCD display back into place.
6. Replace and tighten the LCD display screws to secure the LCD display.
7. Reattach housing cover.
8. Apply power and set the loop to automatic control.

Set the switches without an LCD display

Procedure

1. Set the loop to manual (if applicable) and disconnect the power.
2. Remove the electronics housing cover.
3. Set the alarm and security switches to the desired position.
4. Reattach housing cover.
5. Apply power and set the loop to automatic control.

5 Product certifications

Rev 2.4

5.1 European Directive information

A copy of the EU Declaration of Conformity can be found at the end of the Quick Start Guide. The most recent revision of the EU Declaration of Conformity can be found at Emerson.com/Rosemount.

5.2 Ordinary location certification

As standard, the transmitter has been examined and tested to determine that the design meets the basic electrical, mechanical, and fire protection requirements by a nationally recognized test laboratory (NRTL) as accredited by the Federal Occupational Safety and Health Administration (OSHA).

5.3 North America

5.3.1 E5 FM Explosionproof, Dust-Ignitionproof, and Nonincendive

Certificate FM16US0202X

Standards FM Class 3600: 2011, FM Class 3611: 2004, FM Class 3615: 2006, FM Class 3810: 2005, ANSI/NEMA 250: 1991, ANSI/ISA 60079-0: 2009, ANSI/ISA 60079-11: 2009

Markings **XP** CL I, DIV 1, GP A, B, C, D; T5(-50 °C ≤ T_a ≤ +85 °C);
DIP CL II/III, DIV 1, GP E, F, G; T5(-50 °C ≤ T_a ≤ +75 °C); T6(-50 °C ≤ T_a ≤ +60 °C); when installed per Rosemount drawing 03144-0320;
NI CL I, DIV 2, GP A, B, C, D; T5(-60 °C ≤ T_a ≤ +75 °C); T6(-60 °C ≤ T_a ≤ +60 °C); when installed per Rosemount drawing 03144-0321, 03144-5075.

5.3.2 I5 FM Intrinsic Safety and Nonincendive

Certificate FM16US0202X

Standards FM Class 3600: 2011, FM Class 3610: 2010, FM Class 3611: 2004, FM Class 3810: 2005, ANSI/NEMA 250: 1991, ANSI/ISA 60079-0: 2009, ANSI/ISA 60079-11: 2009

Markings **IS** CL I/II/III, DIV 1, GP A, B, C, D, E, F, G; T4(-60 °C ≤ T_a ≤ +60 °C);
IS [Entity] CL I, Zone 0, AEx ia IIC T4(-60 °C ≤ T_a ≤ +60 °C);
NI CL I, DIV 2, GP A, B, C, D; T5(-60 °C ≤ T_a ≤ +75 °C); T6(-60 °C ≤ T_a ≤ +60 °C); when installed per Rosemount drawing 03144-0321, 03144-5075.

5.3.3 I6 CSA Intrinsic Safety and Division 2

Certificate 1242650

Standards CAN/CSA C22.2 No. 0-M91 (R2001), CAN/CSA-C22.2 No. 94-M91, CSA Std C22.2 No. 142-M1987, CAN/CSA-C22.2 No. 157-92, CSA Std C22.2 No. 213-M1987

Markings Intrinsically Safe for Class I Groups A, B, C, D; Class II, Groups E, F, G; Class III;

[HART only zone markings]: Intrinsically Safe for Class I Zone 0 Group IIC; T4(-50 °C ≤ T_a ≤ +60 °C); Type 4X;

Suitable for Class I, Div. 2, Groups A, B, C, D;

[HART only zone markings]: Suitable for Class I Zone 2 Group IIC; T6(-60 °C ≤ T_a ≤ +60 °C); T5(-60 °C ≤ T_a ≤ +85 °C); when installed per Rosemount drawing 03144-5076.

5.3.4 K6 CSA Explosionproof, Intrinsic Safety, and Division 2

Certificate 1242650

Standards CAN/CSA C22.2 No. 0-M91 (R2001), CSA Std C22.2 No. 25-1966, CSA Std C22.2 No. 30-M1986; CAN/CSA-C22.2 No. 94-M91, CSA Std C22.2 No. 142-M1987, CAN/CSA-C22.2 No. 157-92, CSA Std C22.2 No. 213-M1987

Markings Explosionproof for Class I, Groups A, B, C, D; Class II, Groups E, F, G; Class III;

[HART only zone markings]: Suitable for Class I Zone 1 Group IIC; Intrinsically Safe for Class I Groups A, B, C, D; Class II, Groups E, F, G; Class III;

[HART only zone markings]: Suitable for Class I Zone 0 Group IIC; T4(-50 °C ≤ T_a ≤ +60 °C); Type 4X; Suitable for Class I, Div. 2, Groups A, B, C, D;

[HART only zone markings]: Suitable for Class I Zone 2 Group IIC; T6(-60 °C ≤ T_a ≤ +60 °C); T5(-60 °C ≤ T_a ≤ +85 °C); when installed per Rosemount drawing 03144-5076.

5.4 Europe

5.4.1 E1 ATEX Flameproof

Certificate FM12ATEX0065X

Standards EN 60079-0: 2012+A11:2013, EN 60079-1: 2014, EN 60529:1991 +A1:2000+A2:2013

Markings  II 2 G Ex db IIC T6...T1 Gb, T6(-50 °C ≤ T_a ≤ +40 °C), T5... T1(-50 °C ≤ T_a ≤ +60 °C);
See [Process temperature limits](#) for process temperatures.

Specific Conditions of Use (X):

1. See certificate for ambient temperature range.
2. The non-metallic label may store an electrostatic charge and become a source of ignition in Group III environments.
3. Guard the LCD display cover against impact energies greater than four joules.
4. Flameproof joints are not intended for repair.
5. A suitable certified Ex d or Ex tb enclosure is required to be connected to temperature probes with Enclosure option "N".
6. Care shall be taken by the end user to ensure that the external surface temperature on the equipment and the neck of DIN Style Sensor probe does not exceed 266 °F (130 °C).
7. Non-standard paint options may cause risk of electrostatic discharge. Avoid installations that cause electrostatic build-up on painted surfaces and only clean the painted surfaces with a damp cloth. If paint is ordered through a special option code, contact the manufacturer for more information.

5.4.2 I1 ATEX Intrinsic Safety

Certificate BAS01ATEX1431X [HART]; Baseefa03ATEX0708X [Fieldbus]

Standards EN IEC 60079-0: 2018; EN 60079-11:2012

Markings HART:  II 1 G Ex ia IIC T5/T6 Ga; T6(-60 °C ≤ T_a ≤ +50 °C), T5(-60 °C ≤ T_a ≤ +75 °C)

Fieldbus:  II 1 G Ex ia IIC T4 Ga; T4(-60 °C ≤ T_a ≤ +60 °C)

See [Table 5-9](#) for entity parameters.



Special Conditions for Safe Use (X):

1. When fitted with the transient terminal options, the equipment is not capable of passing the 500 V insulation test. This must be taken into account during installation.
2. The enclosure may be made from aluminum alloy with a protective polyurethane paint finish; however, care should be taken to protect it from impact or abrasion when located in Zone 0.

5.4.3 N1 ATEX Type n

Certificate BAS01ATEX3432X [HART]; Baseefa03ATEX0709X [Fieldbus]

Standards EN IEC 60079-0:2018, EN 60079-15:2010

Markings HART:  II 3 G Ex nA IIC T5/T6 Gc; T6(-40 °C ≤ T_a ≤ +50 °C), T5(-40 °C ≤ T_a ≤ +75 °C);
Fieldbus:  II 3 G Ex nA IIC T5 Gc; T5(-40 °C ≤ T_a ≤ +75 °C);

Special Condition for Safe Use (X):

1. When fitted with the transient terminal options, the equipment is not capable of passing the 500 V electrical strength test as defined in clause 6.5.1 of EN 60079-15: 2010. This must be taken into account during installation.

5.4.4 ND ATEX Dust

Certificate FM12ATEX0065X

Standards EN 60079-0: 2012+A11:2013, EN 60079-31:2014, EN 60529:1991 +A1:2000+A2:2013

Markings  II 2 D Ex tb IIIC T130°C Db, (-40 °C ≤ T_a ≤ +70 °C); IP66
See [Process temperature limits](#) for process temperature.

Specific Conditions of Use (X):

1. See certificate for ambient temperature range.
2. The non-metallic label may store an electrostatic charge and become a source of ignition in Group III environments.
3. Guard the LCD display cover against impact energies greater than four joules.
4. Flameproof joints are not intended for repair.
5. A suitable certified Ex d or Ex tb enclosure is required to be connected to temperature probes with Enclosure option "N".
6. Care shall be taken by the end user to ensure that the external surface temperature on the equipment and the neck of DIN Style Sensor probe does not exceed 266 °F (130 °C).
7. Non-standard paint options may cause risk of electrostatic discharge. Avoid installations that cause electrostatic build-up on painted surfaces and only clean the painted surfaces with a damp cloth. If paint is ordered through a special option code, contact the manufacturer for more information.

5.5 International

5.5.1 E7 IECEx Flameproof

Certificate IECEx FMG 12.0022X

Standards IEC 60079-0:2011, IEC 60079-1:2014-06

Markings Ex db IIC T6...T1 Gb, T6(-50 °C ≤ T_a ≤ +40 °C), T5...T1(-50 °C ≤ T_a ≤ +60 °C)

See [Process temperature limits](#) for process temperatures.

Specific Conditions of Use (X):

1. See certificate for ambient temperature range.
2. The non-metallic label may store an electrostatic charge and become a source of ignition in Group III environments.
3. Guard the LCD display cover against impact energies greater than four joules.
4. Flameproof joints are not intended for repair.
5. A suitable certified Ex d or Ex tb enclosure is required to be connected to temperature probes with Enclosure option "N".
6. Care shall be taken by the end user to ensure that the external surface temperature on the equipment and the neck of DIN Style Sensor probe does not exceed 266 °F (130 °C).
7. Non-standard paint options may cause risk of electrostatic discharge. Avoid installations that cause electrostatic build-up on painted surfaces and only clean the painted surfaces with a damp cloth. If paint is ordered through a special option code, contact the manufacturer for more information.

Additionally available with option K7

IECEx Dust

Certificate IECEx FMG 12.0022X

Standards IEC 60079-0:2011 and IEC 60079-31:2013

Markings Ex tb IIIC T130 °C Db, (-40 °C ≤ T_a ≤ +70 °C); IP66

See [Process temperature limits](#) for process temperatures.

Specific conditions of use (X):

1. See certificate for ambient temperature range.

2. The non-metallic label may store an electrostatic charge and become a source of ignition in Group III environments.
3. Guard the LCD display cover against impact energies greater than four joules.
4. Flameproof joints are not intended for repair.
5. A suitable certified Ex d or Ex tb enclosure is required to be connected to temperature probes with Enclosure option "N".
6. Care shall be taken by the end user to ensure that the external surface temperature on the equipment and the neck of DIN Style Sensor probe does not exceed 266 °F (130 °C).
7. Non-standard paint options may cause risk of electrostatic discharge. Avoid installations that cause electrostatic build-up on painted surfaces and only clean the painted surfaces with a damp cloth. If paint is ordered through a special option code, contact the manufacturer for more information.

5.5.2 I7 IECEx Intrinsic Safety

Certificate IECEx BAS 07.0002X [HART]; IECEx BAS 07.0004X [Fieldbus]

Standards IEC 60079-0: 2017; IEC 60079-11: 2011

Markings HART: Ex ia IIC T5/T6 Ga; T6(-60 °C ≤ T_a ≤ +50 °C), T5(-60 °C ≤ T_a ≤ +75 °C);
 Fieldbus: Ex ia IIC T4 Ga; T4(-60 °C ≤ T_a ≤ +60 °C)
 See [Table 5-9](#) for entity parameters.

Special Conditions for Safe Use (X):

1. When fitted with the transient terminal options, the equipment is not capable of passing the 500 V electrical strength test as defined in Clause 6.3.13 of IEC 60079-11: 2011. This must be taken into account during installation.
2. The enclosure may be made from aluminum alloy with a protective polyurethane paint finish; however, care should be taken to protect it from impact or abrasion when located in Zone 0.

5.5.3 N7 IECEx Type n

Certificate IECEx BAS 07.0003X [HART]; IECEx BAS 07.0005X [Fieldbus]

Standards IEC 60079-0:2017, IEC 60079-15:2010

Markings HART: Ex nA IIC T5/T6 Gc; T6(-40 °C ≤ T_a ≤ +50 °C), T5(-40 °C ≤ T_a ≤ +75 °C);
 Fieldbus: Ex nA IIC T5 Gc; T5(-40 °C ≤ T_a ≤ +75 °C);

Special Condition for Safe Use (X):

1. When fitted with the transient terminal options, the equipment is not capable of passing the 500 V electrical strength test as defined in clause 6.5.1 of EN 60079-15: 2010. This must be taken into account during installation.

5.6 Brazil**5.6.1 E2 INMETRO Flameproof and Dust****Certificate** UL-BR 13.0535X**Standards** ABNT NBR IEC 60079-0:2013; ABNT NBR IEC 60079-1:2016; ABNT NBR IEC 60079-31:2014**Markings** Ex db IIC T6...T1 Gb; T6(-50 °C ≤ T_a ≤ +40 °C); T5...T1(-50 °C ≤ T_a ≤ +60 °C)
Ex tb IIIC T130 °C Db; IP66; (-40 °C ≤ T_a ≤ +70 °C)**Special Conditions for Safe Use (X):**

1. See product description for ambient temperature limits and process temperature limits.
2. The non-metallic label may store an electrostatic charge and become a source of ignition in Group III environments.
3. Guard the LCD display cover against impact energies greater than four joules.
4. Consult the manufacturer if dimensional information on the flameproof joints is necessary.

5.6.2 I2 INMETRO Intrinsic Safety [HART]**Certificate** UL-BR 15.0088X**Standards** ABNT NBR IEC 60079-0:2013, ABNT NBR IEC 60079-11:2013**Markings** Ex ia IIC T6 Ga (-60 °C < T_a < 50 °C), Ex ia IIC T5 Ga (-60 °C < T_a < 75 °C)See [Table 5-9](#) for entity parameters.**Special Conditions for Safe Use (X):**

1. When fitted with the transient terminal options, the equipment is not capable of withstanding the 500 V electrical strength test as defined in ABNT NBR IEC60079-11. This must be taken into account during installation.
2. The enclosure may be made from aluminum alloy with a protective polyurethane paint finish; however, care should be taken to protect it

from impact and abrasion when located in areas that require EPL Ga (Zone 0).

INMETRO Intrinsic Safety [Fieldbus/FISCO]

Certificate UL-BR 15.0030X

Standards ABNT NBR IEC 60079-0:2013, ABNT NBR IEC 60079-11:2013

Markings Ex ia IIC T4 Ga (-60 °C < T_a < +60 °C)
See [Table 5-9](#) at the end of the Product Certifications section for Entity Parameters

Special Conditions for Safe Use (X):

1. When fitted with the transient terminal options, the equipment is not capable of withstanding the 500 V electrical strength test as defined in ABNT NBR IEC60079-11. This must be taken into account during installation.
2. The enclosure may be made from aluminum alloy with a protective polyurethane paint finish; however, care should be taken to protect it from impact and abrasion when located in areas that require EPL Ga (Zone 0).

5.7 China

5.7.1 E3 China Flameproof

Certificate GYJ16.1339X

Standards GB3836.1-2010, GB3836.2-2010

Markings Ex d IIC T6...T1 Gb

- 产品安全使用特殊条件
证书编号后缀“X”表明产品具有安全使用特殊条件：涉及隔爆接合面的维修须联系产品制造商。
- 产品使用注意事项
 1. 产品使用环境温度与温度组别的关系为：

温度组别	环境温度
T6~T1	-50 °C ≤ T _a ≤ +40 °C
T5~T1	-50 °C ≤ T _a ≤ +60 °C

2. 产品外壳设有接地端子，用户在使用时应可靠接地
3. 安装现场应不存在对产品外壳有腐蚀作用的有害气体

4. 现场安装时，电缆引入口须选用国家指定的防爆检验机构按检验认可、具有 Ex dIIC 防爆等级的电缆引入装置或堵封件，冗余电缆引入口须用堵封件有效密封
5. 现场安装、使用和维护必须严格遵守“断电后开盖！”的警告语
6. 用户不得自行更换该产品的零部件，应会同产品制造商共同解决运行中出现的故障，以杜绝损坏现象的发生
7. 产品的安装、使用和维护应同时遵守产品使用说明书、GB3836.13-2013“爆炸性环境 第 13 部分：设备的修理、检修、修复和改造”、GB3836.15-2000“爆炸性气体环境用电气设备 第 15 部分：危险场所电气安装（煤矿除外）”、GB3836.16-2006“爆炸性气体环境用电气设备 第 16 部分：电气装置的检查和维修（煤矿除外）”和 GB50257-2014“电气装置安装工程爆炸和火灾危险环境电力装置施工及验收规范”的有关规定

5.7.2 I3 China Intrinsic Safety

Certificate GY16.1338X

Standards GB3836.1-2010, GB3836.4-2010, GB3836.20-2010

Markings Ex ia IIC T4/T5/T6 Ga

- 产品安全使用特殊条件
证书编号后缀“X”表明产品具有安全使用特殊条件：
 1. 产品外壳含有轻金属，用于 0 区时需注意防止由于冲击或摩擦产生的点燃危险
 2. 产品选用瞬态保护端子板（选项代码为 T1）时，此设备不能承受 GB3836.4-2010 标准中第 6.3.12 条规定的 500V 交流有效值试验电压的介电强度试验
- 产品使用注意事项
 1. 产品温度组别与使用环境温度范围的关系：

输出	温度组别	环境温度
HART®	T6	$-60\text{ }^{\circ}\text{C} \leq T_a \leq +50\text{ }^{\circ}\text{C}$
	T5	$-60\text{ }^{\circ}\text{C} \leq T_a \leq +75\text{ }^{\circ}\text{C}$
Fieldbus	T4	$-60\text{ }^{\circ}\text{C} \leq T_a \leq +60\text{ }^{\circ}\text{C}$

2. 本安电气参数：

Table 5-1: Power Loop Terminals (+ and -)

输出	最高输入电压 U_i (V)	最大输入电流 I_i (mA)	最大输入功率 P_i (W)	最大内部等效参数	
				C_i (nF)	L_i (μ H)
HART	30	300	1	5	0
Fieldbus	30	300	1.3	2.1	0

Table 5-2: Sensor Terminals (1 to 5)

输出	最高输出电压 U_o (V)	最大输出电流 I_o (mA)	最大输出功率 P_o (W)	最大内部等效参数	
				C_o (nF)	L_o (μ H)
HART	13.6	56	0.19	78	0
Fieldbus	13.9	23	0.079	7.7	0

Table 5-3: Load Connected to Sensor Terminals (1 to 5)

输出	组别	最大外部等效电路	
		C_o (μ F)	L_o (mH)
HART	IIC	0.74	11.7
	IIB	5.12	44
	IIA	18.52	94
Fieldbus	IIC	0.73	30.2
	IIB	4.8	110.9
	IIA	17.69	231.2

温度变送器符合 GB3836.19-2010 标准对 FISCO 系统中现场仪表的有关要求

其本安参数及内部最大等效参数如下:

最高输入电压 U_i (V)	最大输入电流 I_i (mA)	最大输入功率 P_i (W)	最大内部等效参数	
			C_i (nF)	L_i (mH)
17.5	380	5.32	2.1	0

3. 该产品必须与已通过防爆认证的关联设备配套共同组成本安防爆系统方可用于爆炸性气体环境。其系统接线必须同时遵守本产品 and 所配关联设备的使用说明书要求，接线端子不得接错

4. 该产品与关联设备的连接电缆应为带绝缘护套的屏蔽电缆，其屏蔽层应在安全场所接地
5. 用户不得自行更换该产品的零部件，应会同产品制造商共同解决运行中出现的故障，以杜绝损坏现象的发生
6. 产品的安装、使用和维护应同时遵守产品使用说明书、GB3836.13-2013“爆炸性环境 第 13 部分：设备的修理、检修、修复和改造”、GB3836.15-2000“爆炸性气体环境用电气设备 第 15 部分：危险场所电气安装（煤矿除外）”、GB3836.16-2006“爆炸性气体环境用电气设备 第 16 部分：电气装置的检查和维修（煤矿除外）”、GB3836.18-2010“爆炸性环境 第 18 部分：本质安全系统”和 GB50257-2014“电气装置安装工程爆炸和火灾危险环境电力装置施工及验收规范”的有关规定

5.7.3 N3 China Type n

Certificate GYJ20.1086X [Fieldbus]; GYJ20.1091X [HART]

Standards GB3836.1-2010, GB3836.8-2014

Markings Ex nA IIC T5 Gc [Fieldbus]; Ex nA IIC T5/T6 Gc [HART]

Output	T code	Ambient temperature
Fieldbus	T5	$-40^{\circ}\text{C} \leq T_a \leq +75^{\circ}\text{C}$
HART	T6	$-40^{\circ}\text{C} \leq T_a \leq +50^{\circ}\text{C}$
	T5	$-40^{\circ}\text{C} \leq T_a \leq +75^{\circ}\text{C}$

- 产品安全使用特殊条件

产品防爆合格证后缀“X”代表产品安全使用有特殊条件，即：当使用瞬态保护选项，此设备不能承受 GB3836.8-2003 标准中第 8.1 条规定的 500V 耐压试验，安装时必须考虑在内

- 产品使用注意事项

1. 产品使用环境温度为： $-40^{\circ}\text{C} \leq T_a \leq +70^{\circ}\text{C}$ (Fieldbus)
HART

Table 5-4: HART

温度组别	环境温度
T5	$-40^{\circ}\text{C} \leq T_a \leq +75^{\circ}\text{C}$
T6	$-40^{\circ}\text{C} \leq T_a \leq +50^{\circ}\text{C}$

2. 输入电压：32 Vdc (Fieldbus) ， 42.4 Vdc (HART)

3. 现场安装时，电缆引入口须选用经国家指定的防爆检验机构检验认可的 Exe 或 Exn 型、螺纹规格为 14NPT 的电缆引入装置或封堵件，冗余电缆引入口须用封堵件有效密封
4. 现场安装时，电缆引入口须选用经国家指定的防爆检验机构检验认可的 Exe 或 Exn 型、螺纹规格为 14NPT 的电缆引入装置或封堵件，冗余电缆引入口须用封堵件有效密封
5. 安装现场确认无可燃性气体存在时方可维修
6. 用户不得自行更换该产品的零部件，应会同产品制造商共同解决运行中出现的故障，以杜绝损坏现象的发生
7. 产品的安装、使用和维护应同时遵守产品使用说明书、GB3836.13-2013“爆炸性环境 第 13 部分：设备的修理、检修、修复和改造”、GB3836.15-2000“爆炸性气体环境用电气设备 第 15 部分：危险场所电气安装（煤矿除外）”、GB3836.16-2006“爆炸性气体环境用电气设备 第 16 部分：电气装置的检查和维护（煤矿除外）”和 GB50257-2014“电气装置安装工程爆炸和火灾危险环境电力装置施工及验收规范”的有关规定。

5.8 EAC - Belarus, Kazakhstan, Russia

5.8.1 EM Technical Regulation Customs Union (EAC) Flameproof

Standards GOST 31610.0-2014, GOST IEC 60079-1-2013

Markings 1Ex db IIC T6...T1 Gb X, T6(-50 °C ≤ T_a ≤ +40 °C), T5...T1(-50 °C ≤ T_a ≤ +60 °C)

See [Process temperature limits](#) for process temperatures.

Special Condition for Safe Use (X):

1. Non-standard paint options may cause risk of electrostatic discharge. Avoid installations that cause electrostatic build-up on painted surfaces and only clean the painted surfaces with a damp cloth. If paint is ordered through a special option code, contact the manufacturer for more information.

5.8.2 IM Technical Regulation Customs Union (EAC) Intrinsic Safety

Standards GOST 31610.0-2014, GOST IEC 60079-11-2014

Markings [HART]: 0Ex ia IIC T5, T6 Ga X, T6(-60 °C ≤ T_a ≤ +50 °C), T5(-60 °C ≤ T_a ≤ +75 °C);
[Fieldbus/PROFIBUS]: 0Ex ia IIC T4 Ga X, T4(-60 °C ≤ T_a ≤ +60 °C)

See [Table 5-9](#) for entity parameters.

Special Conditions for Safe Use (X):

1. When fitted with the transient terminal options, the apparatus is not capable of withstanding the 500 V electrical strength test as defined

in Clause 6.3.13 of GOST 31610.11-2014. This must be taken into account during installation.

- The enclosure may be made from aluminum alloy with a protective polyurethane paint finish; however, care should be taken to protect it from impact or abrasion when located in Zone 0.

5.8.3 KM Technical Regulation Customs Union (EAC) Flameproof, Intrinsic Safety, and Dust

Standards GOST 31610.0-2014, GOST IEC 60079-1-2013, GOST IEC 60079-11-2014, GOST IEC 60079-31-2013

Markings Ex tb IIIC T130 °C Db X ($-40\text{ °C} \leq T_a \leq +70\text{ °C}$), IP 66 in addition to markings listed for EM and IM above.

Special Condition for Safe Use (X):

- See certificate for special conditions.

5.9 Japan

5.9.1 E4 TIIS Flameproof

Certificate TC21038, TC21039

Markings Ex d IIC T5 ($-20\text{ °C} \leq T_a \leq +60\text{ °C}$)

Certificate TC16127, TC16128, TC16129, TC16130

Markings Ex d IIB T4 ($-20\text{ °C} \leq T_a \leq +55\text{ °C}$)

5.10 Korea

5.10.1 EP Korea Flameproof

Certificate 10-KB4BO-0011X

Markings Ex d IIC T6/T5; T6($-40\text{ °C} \leq T_{amb} \leq +70\text{ °C}$), T5($-40\text{ °C} \leq T_{amb} \leq +80\text{ °C}$)

Special Condition for Safe Use (X):

- See certificate for special conditions.

5.10.2 IP Korea Intrinsic Safety

Certificate 09-KB4BO-0028X

Markings Ex ia IIC T6/T5; T6($-60\text{ °C} \leq T_{amb} \leq +50\text{ °C}$), T5($-60\text{ °C} \leq T_{amb} \leq +75\text{ °C}$)

Special Condition for Safe Use (X):

1. See certificate for special conditions.

5.11 Combinations

- K1** Combination of E1, I1, N1, and ND
- K2** Combination of E2 and I2
- K5** Combination of E5 and I5
- KB** Combination of K5, I6, and K6
- KP** Combination of EP and IP

5.12 Tables

Process temperature limits

Table 5-5: Sensor Only (No Transmitter Installed)

Extension length	Process temperature [°C]						
	Gas						Dust
	T6	T5	T4	T3	T2	T1	T130 °C
Any extension length	85	100	135	200	300	450	130

Table 5-6: Transmitter

Extension length	Process temperature [°C]						
	Gas						Dust
	T6	T5	T4	T3	T2	T1	T130 °C
No extension	55	70	100	170	280	440	100
3-in. extension	55	70	110	190	300	450	110
6-in. extension	60	70	120	200	300	450	110
9-in. extension	65	75	130	200	300	450	120

Adhering to the process temperature limitations of [Table 5-7](#) will ensure that the service temperature limitations of the LCD display cover are not exceeded. Process temperatures may exceed the limits defined in [Table 5-7](#) if the temperature of the LCD display cover is verified to not exceed the service temperatures in [Table 5-8](#) and the process temperatures do not exceed the values specified in [Table 5-6](#).

Table 5-7: Transmitter with LCD Display Cover

Extension length	Process temperature [° C]			
	Gas			Dust
	T6	T5	T4...T1	T130 °C
No extension	55	70	95	95
3-in. extension	55	70	100	100
6-in. extension	60	70	100	100
9-in. extension	65	75	110	110

Table 5-8: Transmitter with LCD Display Cover

Extension length	Service temperature [° C]			
	Gas			Dust
	T6	T5	T4...T1	T130 °C
Any extension length	65	75	95	95

Entity parameters

Table 5-9: Entity Parameters

Parameters	HART	Fieldbus/ PROFIBUS	FISCO
Voltage U_i (V)	30	30	17.5
Current I_i (mA)	300	300	380
Power P_i (W)	1	1.3	5.32
Capacitance C_i (nF)	5	2.1	2.1
Inductance L_i (mH)	0	0	0

5.13 Additional certifications

SBS American Bureau of Shipping (ABS) Type Approval

Certificate 16-HS1488352-PDA

Intended use Measurement of temperature for marine and offshore applications

SBV Bureau Veritas (BV) Type Approval

Certificate 23154

Requirements Bureau Veritas Rules for the Classification of Steel Ships

Application Class notations: AUT-UMS, AUT-CCS, AUT-PORT and AUT-IMS; Temperature transmitter type 3144P cannot be installed on diesel engines.

SDN Det Norske Veritas (DNV) Type Approval

Certificate TAA00001JK

Intended use Det Norske Veritas’ Rules for Classification of Ships, High Speed & Light Craft and Det Norske Veritas’ Offshore Standards

Application **Table 5-10: Location Classes**



Temperature	D
Humidity	B
Vibration	A
EMC	A
Enclosure	D



SLL Lloyds Register (LR) type approval

Certificate 11/60002

Application Environmental categories ENV1, ENV2, ENV3, and ENV5

5.14 Declaration of conformity

	EU Declaration of Conformity	
No: RMD 1045 Rev. N		
We,		
Rosemount, Inc. 8200 Market Boulevard Chanhassen, MN 55317-9685 USA		
declare under our sole responsibility that the product,		
Rosemount™ 3144P Temperature Transmitter		
manufactured by,		
Rosemount, Inc. 8200 Market Boulevard Chanhassen, MN 55317-9685 USA		
to which this declaration relates, is in conformity with the provisions of the European Union Directives, including the latest amendments, as shown in the attached schedule.		
Assumption of conformity is based on the application of the harmonized standards and, when applicable or required, a European Union notified body certification, as shown in the attached schedule.		
	Vice President of Global Quality	
(signature)	(function)	
Chris LaPoint	4-Sept-2019	
(name)	(date of issue)	
Page 1 of 3		

 **EU Declaration of Conformity** 

No: RMD 1045 Rev. N

EMC Directive (2014/30/EU)

Harmonized Standards: EN61326-1:2013, EN61326-2-3: 2013

ATEX Directive (2014/34/EU)

Rosemount 3144P Temperature Transmitter (4-20mA/HART Output)

BAS01ATEX1431X – Intrinsic Safety Certificate
Equipment Group II, Category 1 G (Ex ia IIC T5/T6 Ga)
Harmonized Standards:
EN IEC 60079-0:2018, EN60079-11:2012



BAS01ATEX3432X – Type n Certificate
Equipment Group II, Category 3 G (Ex nA IIC T5/T6 Gc)
Harmonized Standards:
EN IEC 60079-0:2018, EN60079-15:2010

Rosemount 3144P Temperature Transmitter (Fieldbus Output)

Baseefa03ATEX0708X – Intrinsic Safety Certificate
Equipment Group II, Category 1 G (Ex ia IIC T4 Ga)
Harmonized Standards:
EN IEC 60079-0:2018, EN60079-11:2012

Baseefa03ATEX0709 – Type n Certificate
Equipment Group II, Category 3 G (Ex nA IIC T5 Gc)
Harmonized Standards:
EN IEC 60079-0:2018, EN60079-15:2010

Page 2 of 3

	
EU Declaration of Conformity No: RMD 1045 Rev. N	
Rosemount 3144P Temperature Transmitter (all Output Protocols)	
FMI2ATEX0065X – Dust Certificate Equipment Group II, Category 2 D (Ex tb IIIC T130°C Db) Harmonized Standards: EN 60079-0:2012+A11:2013, EN 60079-31:2014	
FMI2ATEX0065X – Flameproof Certificate Equipment Group II, Category 2 G (Ex db IIC T6...T1 Gb) Harmonized Standards: EN 60079-0:2012+A11:2013, EN 60079-1:2014	
ATEX Notified Bodies	
SGS FIMKO OY [Notified Body Number: 0598] P.O. Box 30 (Sarkaniementie 3) 00211 HELSINKI Finland	
FM Approvals Europe Limited [Notified Body Number: 2309] One Georges Quay Plaza Dublin, Ireland. D02 E440	
ATEX Notified Body for Quality Assurance	
SGS FIMKO OY [Notified Body Number: 0598] P.O. Box 30 (Sarkaniementie 3) 00211 HELSINKI Finland	
Page 3 of 3	

5.15 China RoHS

有害物质成分表
00079-2000, Rev AB

罗斯蒙特产品型号 **3144P**
7/1/2016

含有 China RoHS 管控物质超过最大浓度限值的部件型号列表 3144P
List of 3144P Parts with China RoHS Concentration above MCVs

部件名称 Part Name	有害物质 / Hazardous Substances					
	铅 Lead (Pb)	汞 Mercury (Hg)	镉 Cadmium (Cd)	六价铬 Hexavalent Chromium (Cr +6)	多溴联苯 Polybrominated biphenyls (PBB)	多溴联苯醚 Polybrominated diphenyl ethers (PBDE)
电子组件 Electronics Assembly	X	○	○	○	○	○
壳体组件 Housing Assembly	○	○	○	X	○	○
传感器组件 Sensor Assembly	X	○	○	○	○	○

本表格系依据 SJ/T11364 的规定而制作。

This table is proposed in accordance with the provision of SJ/T11364.

○: 意为该部件的所有均质材料中该有害物质的含量均低于 GB/T 26572 所规定的限量要求。

O: Indicate that said hazardous substance in all of the homogeneous materials for this part is below the limit requirement of GB/T 26572.

X: 意为在该部件所使用的的所有均质材料里，至少有一类均质材料中该有害物质的含量高于 GB/T 26572 所规定的限量要求。

X: Indicate that said hazardous substance contained in at least one of the homogeneous materials used for this part is above the limit requirement of GB/T 26572.

部件名称 Part Name	组装备件说明 Spare Parts Descriptions for Assemblies
电子组件 Electronics Assembly	电子线路板组件 Electronic Board Assemblies 端子块组件 Terminal Block Assemblies 液晶显示屏或本地操作界面 LCD or LOI Display
壳体组件 Housing Assembly	电子外壳 Electrical Housing



Global Headquarters

Emerson Automation Solutions
6021 Innovation Blvd.
Shakopee, MN 55379, USA

- +1 800 999 9307 or +1 952 906 8888
- +1 952 204 8889
- RFQ.RMD-RCC@Emerson.com

Latin America Regional Office

Emerson Automation Solutions
1300 Concord Terrace, Suite 400
Sunrise, FL 33323, USA

- +1 954 846 5030
- +1 954 846 5121
- RFQ.RMD-RCC@Emerson.com

Asia Pacific Regional Office

Emerson Automation Solutions
1 Pandan Crescent
Singapore 128461

- +65 6777 8211
- +65 6777 0947
- Enquiries@AP.Emerson.com

 [Linkedin.com/company/Emerson-Automation-Solutions](https://www.linkedin.com/company/Emerson-Automation-Solutions)

 [Twitter.com/Rosemount_News](https://twitter.com/Rosemount_News)

 [Facebook.com/Rosemount](https://www.facebook.com/Rosemount)

 [Youtube.com/user/RosemountMeasurement](https://www.youtube.com/user/RosemountMeasurement)

North America Regional Office

Emerson Automation Solutions
8200 Market Blvd.
Chanhassen, MN 55317, USA

- +1 800 999 9307 or +1 952 906 8888
- +1 952 204 8889
- RMT-NA.RCCRFQ@Emerson.com

Europe Regional Office

Emerson Automation Solutions Europe
GmbH
Neuhofstrasse 19a P.O. Box 1046
CH 6340 Baar
Switzerland

- +41 (0) 41 768 6111
- +41 (0) 41 768 6300
- RFQ.RMD-RCC@Emerson.com

Middle East and Africa Regional Office

Emerson Automation Solutions
Emerson FZE P.O. Box 17033
Jebel Ali Free Zone - South 2
Dubai, United Arab Emirates

- +971 4 8118100
- +971 4 8865465
- RFQ.RMTMEA@Emerson.com

©2020 Emerson. All rights reserved.

Emerson Terms and Conditions of Sale are available upon request. The Emerson logo is a trademark and service mark of Emerson Electric Co. Rosemount is a mark of one of the Emerson family of companies. All other marks are the property of their respective owners.