



PolyChem™ Non-Metallic Chemical Process Pumps

ASME and ISO

M-Series

S-Series

GRP

VGRP

Pump Supplier To The World

Flowserve is the driving force in the global industrial pump marketplace. No other pump company in the world has the depth or breadth of expertise in the successful application of pre-engineered, engineered, and special purpose pumps and systems.

Pumping Solutions

Flowserve is providing pumping solutions which permit customers to continuously improve productivity, profitability and pumping system reliability.

Market-Focused Customer Support

Product and industry specialists develop effective proposals and solutions directed toward market and customer preferences. They offer technical advice and assistance throughout each stage of the product life cycle, beginning with the inquiry.



Dynamic Technologies

Flowserve is without peer in the development and application of pump technology, including:

- Hydraulic engineering
- Mechanical design
- Materials science
- Intelligent pumping
- Manufacturing technology

Broad Product Lines

Flowserve offers a wide range of complementary pump types, from pre-engineered process pumps, to highly engineered and special purpose pumps and systems. Pumps are built to recognized global standards and customer specifications.

Pump designs include:

- Single-stage process
- Between bearing single-stage
- Between bearing multistage
- Vertical
- Submersible motor
- Positive displacement
- Nuclear
- Specialty

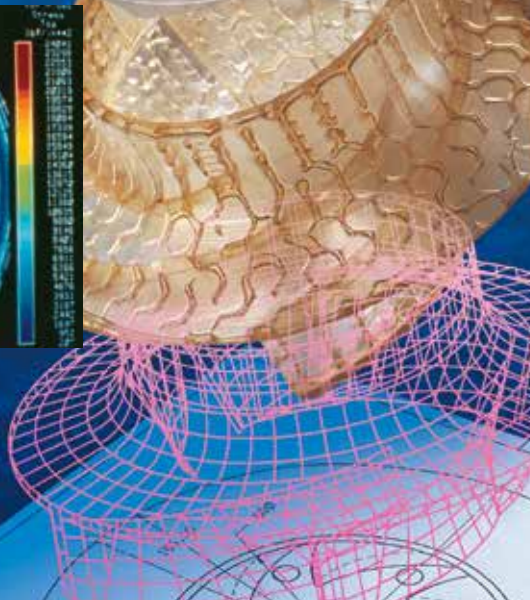
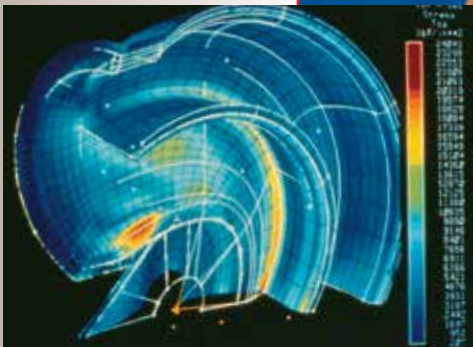
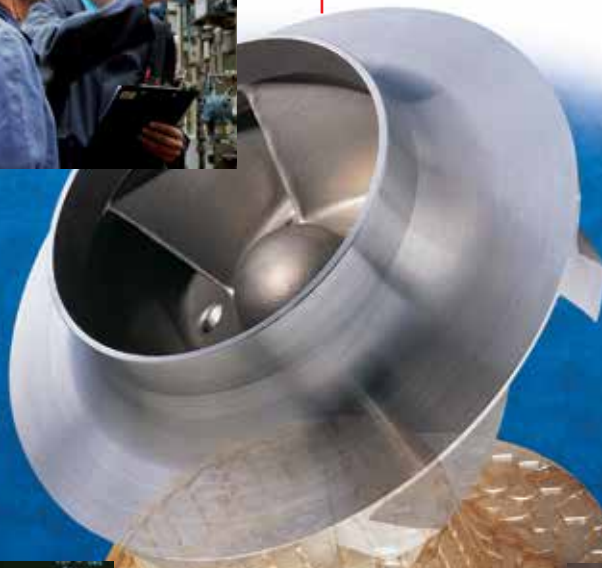

**PolyChem
Non-Metallic
Chemical Process
Pumps**

Non-Metallic Pumps Designed to Global Standards

Embracing a global approach to pump design, Flowserve offers sealed and sealless PolyChem non-metallic pumps engineered to ASME and ISO design criteria and to JIS drilling specifications. The fluoropolymer lined M-Series and S-Series pumps and the GRP engineered polymer composite pump are well suited for highly corrosive applications in the worldwide process industries.

Applications

- Chemical plants
- Steel and primary metals industry
- Marine environments
- Wastewater treatment
- Aquariums
- Mining works
- Microchip manufacturing

Complementary Pump Designs

- Mark 3™ ASME metallic chemical process pump
- Mark 3 ASME in-line chemical process pump
- Mark 3 ISO metallic chemical process pump

Table of Contents

PolyChem M-Series
PFA Lined Sealless Pumps..... 4–8
ASME and ISO Performance Curves 9

PolyChem S-Series
PFA Lined Mechanically Sealed Pumps 10–11
Sealing Options 12
ASME and ISO Performance Curves 13

PolyChem GRP and VGRP Pumps
Engineered Composite Pumps..... 14–16
ASME Performance Curves..... 17

Baseplates and Pump Accessories
Baseplates 18–19
ClearGuard™ 20
DurcoShield™ 20
Power Monitor 20
PROS+..... 20

Complementary Pumps
CPXS and Guardian Magnetic Drive Pumps..... 21
Mark 3 ISO Pumps..... 21
Mark 3 ASME Standard and In-Line Pumps..... 22

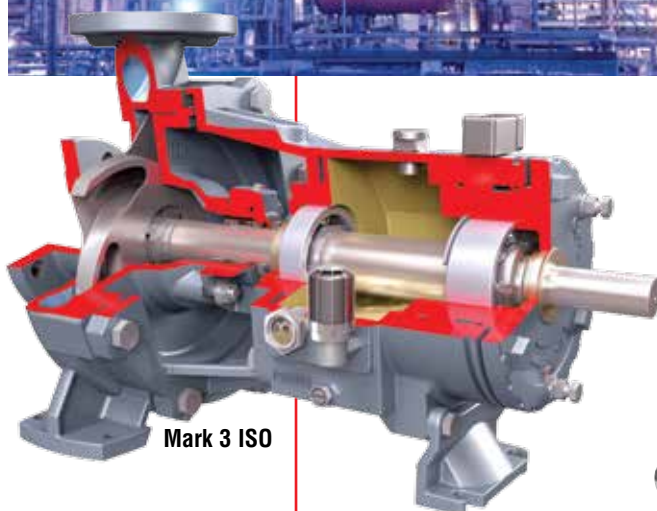

Mark 3 ISO

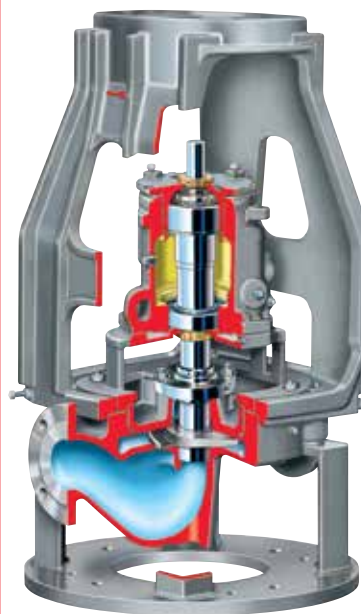

Mark 3 In-Line

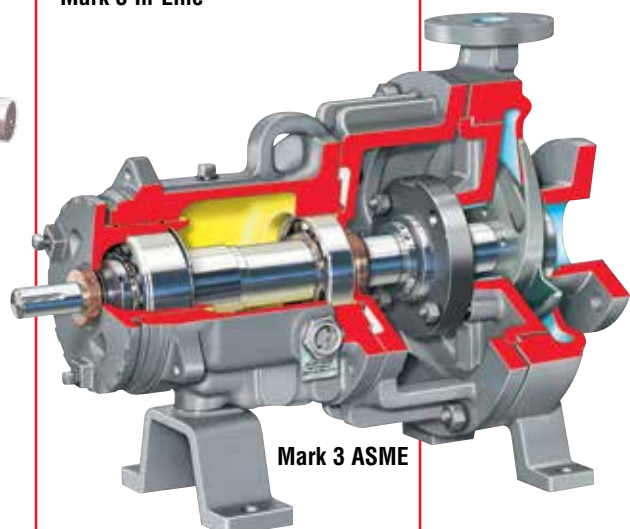

Mark 3 ASME

**PolyChem M-Series
Fluoropolymer Lined
Sealless Pumps
Close Coupled**

Worldwide Application

The PolyChem M-Series fluoropolymer lined, close coupled, magnetically driven, chemical process pump is the result of extensive global market research. M-Series sealless pumps are rugged, heavy-duty pumps designed specifically for reliable, leak-free performance in demanding process applications.

Addressing customer needs around the globe, PolyChem M-Series pumps meet the following dimensional standards:

- ASME B73.1
- ISO 2858
- JIS drilling

Operating Parameters

- Flows to 135 m³/h (600 gpm)
- Heads to 145 m (480 ft)
- Pressures to 17 bar (250 psi)
- Temperatures from -30°C (-20°F) to 150°C (300°F)

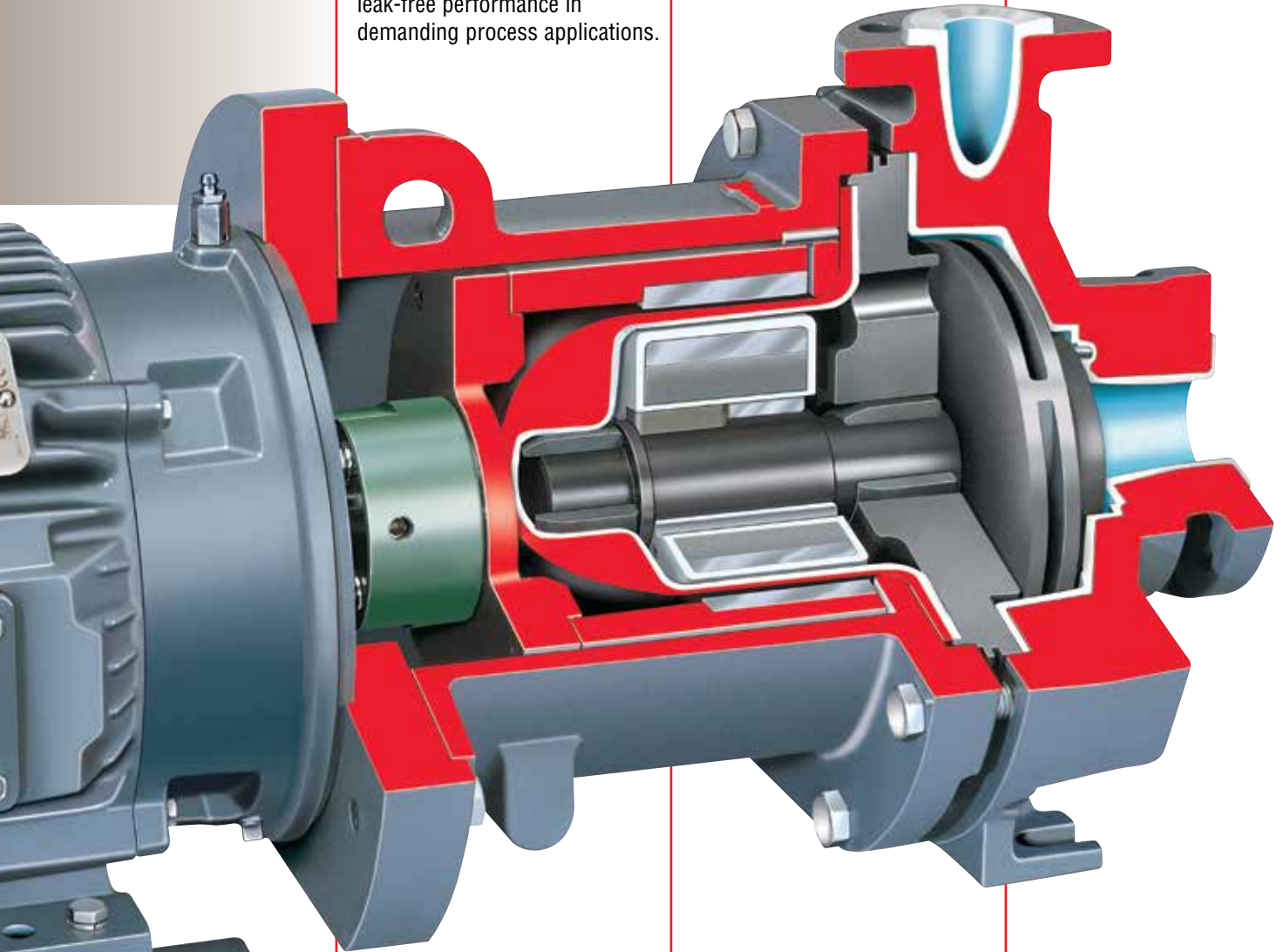

Close Coupled Configuration minimizes space requirements with no need for shaft alignment.

Fluoropolymer Lined Fiberglass Containment Shell offers superior corrosion resistance and strength.

Fluoropolymer PFA Lined Wet End is globally preferred for its superior corrosion resistance and temperature allowance. PFA is carbon reinforced where required for stiffness and strength.

Rare Earth Magnets in synchronous drive design eliminate slippage and permit high temperature application.

Separate Inner Magnet and Impeller Components result in low cost maintenance and ease of upgrade.

Rugged Silicon Carbide Radial and Axial Thrust Bearings offer outstanding wear resistance and chemical inertness.

Jackbolts offer added safety for plant personnel and facilitate maintenance.

Back Pull-out Design allows for pump removal without disturbing the casing.

Non-sparking Rub Pads prevent contact of critical components in the unlikely event of outer magnet support bearing failure.

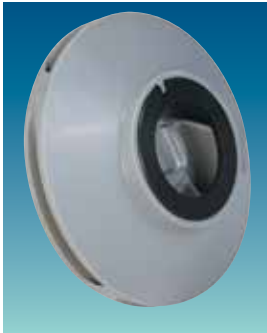

Enclosed Lined Impeller provides balanced hydraulic loads, extending bearing life.

Rugged Design With the Customer in Mind

PolyChem M-Series pumps were designed to offer the optimum in pump reliability and value, while maintaining a simple design for safety and ease of maintenance.

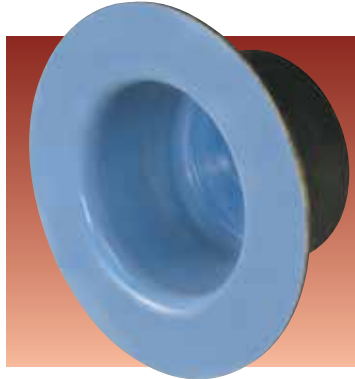

PFA Lined Casing

The Flowserve proprietary PFA molding processes ensure liner integrity.

- Ductile cast iron armor has a minimum PFA liner thickness of 3 mm (0.125 in).
- Armor meets ASTM A395 and GGG40.3 specifications.

PFA Lined Fiberglass

Containment Shell is rated to 17 bar (250 psi) and offers excellent magnet efficiencies. Non-metallic construction eliminates magnetic losses and heat generation associated with metallic containment shells. The result is a more energy-efficient pump that uses a smaller motor and is less likely to cause vaporization of the pumping fluid.



Large Silicon Carbide Rotating Shaft Offers

ruggedness simply not found in other non-metallic pumps. PolyChem's rotating shaft is supported by silicon carbide bearings located securely in a reinforced fluoropolymer bearing holder, thereby eliminating the need for bearing support in the inlet of the pump.

Standard Silicon Carbide Radial and Axial Thrust Bearings

are chemically inert and have exceptional wear resistance.

Simplicity in Design

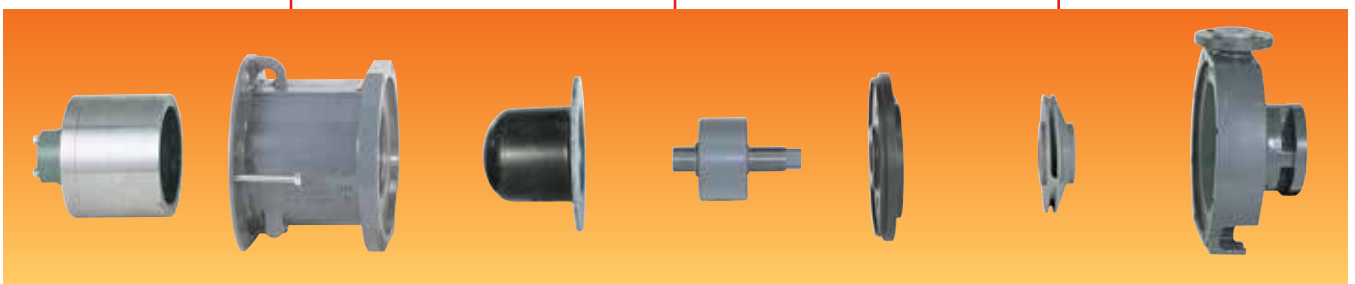

**PolyChem M-Series
Fluoropolymer Lined
Sealless Pumps
Long Coupled**

Worldwide Application

The PolyChem M-Series fluoropolymer lined, long coupled, magnetically driven, chemical process pump is the result of extensive global market research. M-Series sealless pumps are rugged, heavy-duty pumps designed specifically for reliable, leak-free performance in demanding process applications.

Addressing customer needs around the globe, PolyChem M-Series pumps meet the following dimensional standards:

- ASME B73.1
- ISO 2858
- JIS drilling

Operating Parameters

- Flows to 135 m³/h (600 gpm)
- Heads to 145 m (480 ft)
- Pressures to 17 bar (250 psi)
- Temperatures from -30°C (-20°F) to 150°C (300°F)

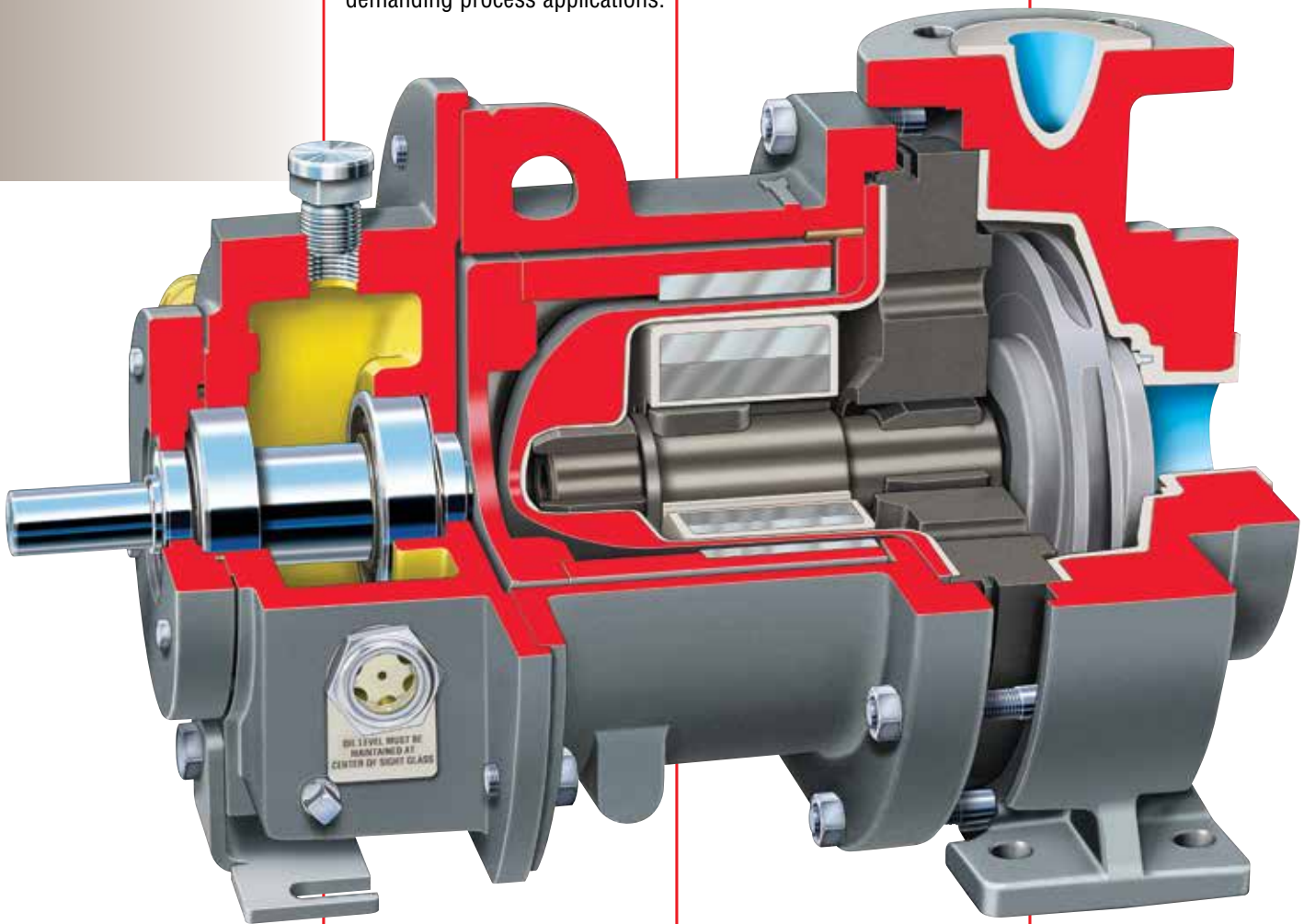

Long Coupled Configuration offers traditional bearing housing with flexible coupling.

Fluoropolymer Lined Fiberglass Containment Shell offers superior corrosion resistance and strength.

Fluoropolymer PFA Lined Wet End is globally preferred for its superior corrosion resistance and temperature allowance. PFA is carbon reinforced where required for stiffness and strength.

Rare Earth Magnets in synchronous drive design eliminate slippage and permit high temperature application.

Separate Inner Magnet and Impeller Components result in low cost maintenance and ease of upgrade.

Rugged Silicon Carbide Radial and Axial Thrust Bearings offer outstanding wear resistance and chemical inertness.

Power Frame Pull-out permits safe power end maintenance without breaking sealed containment.

Jackbolts offer added safety for plant personnel and facilitate maintenance.

Back Pull-out Design allows for pump removal without disturbing the casing.

Non-sparking Rub Pads prevent contact of critical components in the unlikely event of outer magnet support bearing failure.

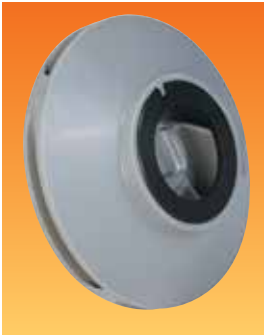

Enclosed Lined Impeller provides balanced hydraulic loads, extending bearing life.

Rugged Design With the Customer in Mind

PolyChem M-Series pumps were designed to offer the optimum in pump reliability and value, while maintaining a simple design for safety and ease of maintenance.

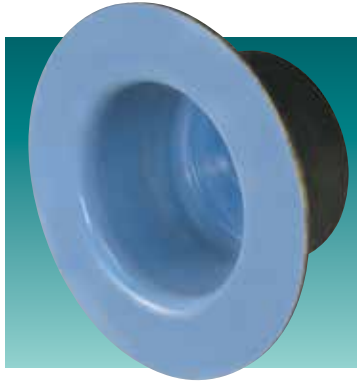

PFA Lined Casing

The Flowserve proprietary PFA molding processes ensure liner integrity.

- Ductile cast iron armor has a minimum PFA liner thickness of 3 mm (0.125 in).
- Armor meets ASTM A395 and GGG40.3 specifications.

PFA Lined Fiberglass

Containment Shell is rated to 17 bar (250 psi) and offers excellent magnet efficiencies. Non-metallic construction eliminates magnetic losses and heat generation associated with metallic containment shells. The result is a more energy-efficient pump that uses a smaller motor and is less likely to cause vaporization of the pumping fluid.



Large Silicon Carbide Rotating Shaft Offers

ruggedness simply not found in other non-metallic pumps. PolyChem's rotating shaft is supported by silicon carbide bearings located securely in a reinforced fluoropolymer bearing holder, thereby eliminating the need for bearing support in the inlet of the pump.

Standard Silicon Carbide Radial and Axial Thrust Bearings

are chemically inert and have exceptional wear resistance.

Simplicity in Design

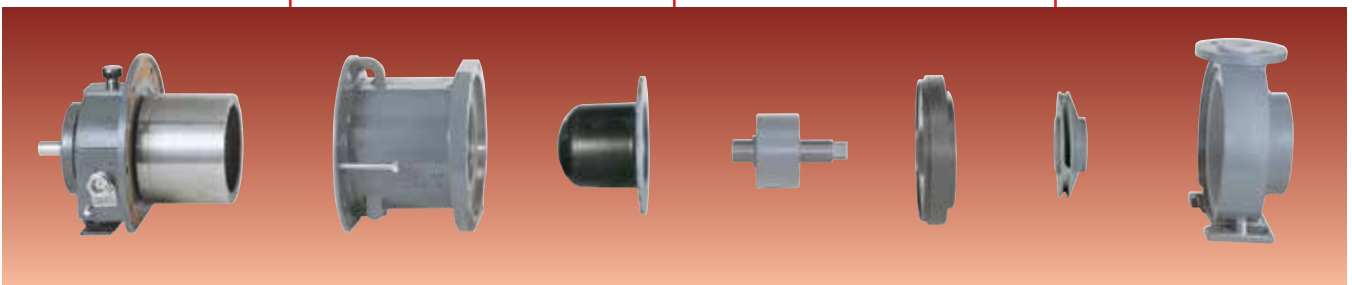

**PolyChem M-Series
Fluoropolymer Lined
Sealless Pumps**

**Technical
Information**

M-Series pumps are designed for superior performance and reliability at reduced cost.

Internal Circulation and Lubrication Path is engineered for optimum performance.

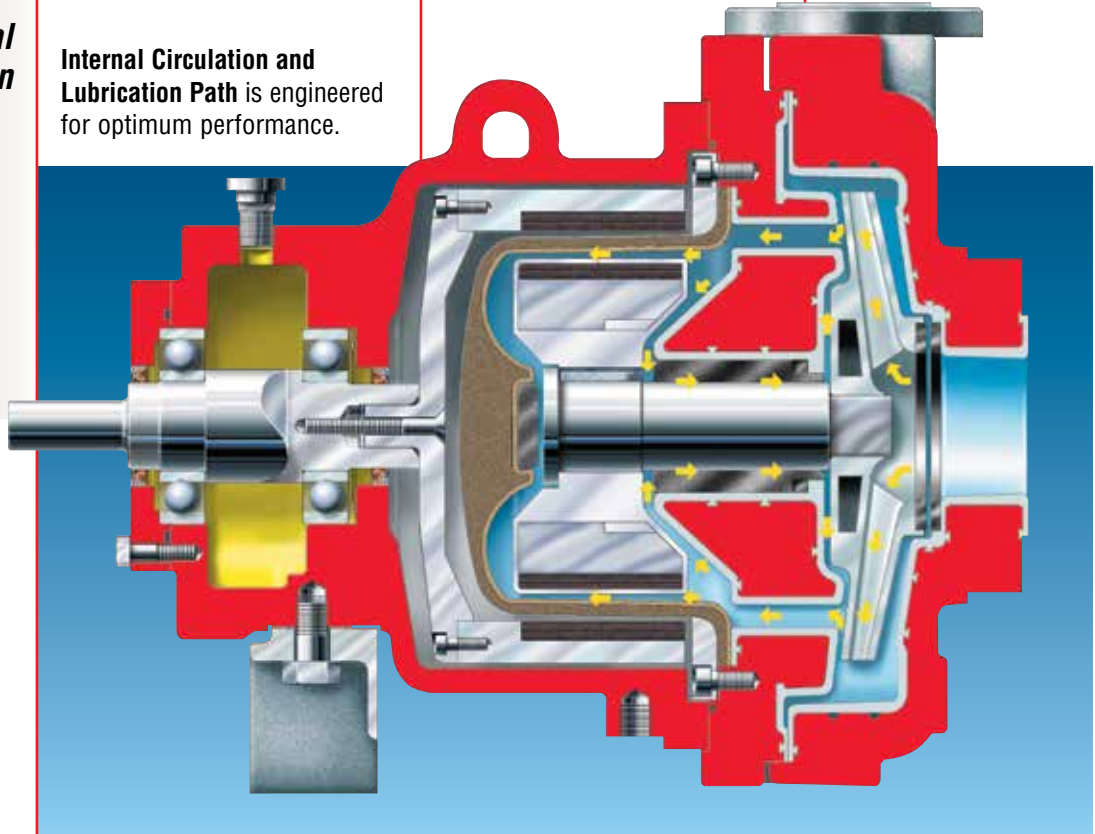

Separate Inner Magnet and Impeller Components significantly reduce impeller replacement cost compared with integral assembly designs.

Rotating Shaft Design eliminates shaft support obstructions in the casing inlet, which are common with stationary shaft designs.

- Improved performance
- Reduced NPSHR

**PolyChem
M-Series
Performance
Curves**

PolyChem M-Series sealless pumps cover a broad hydraulic range.

Thirteen Sizes

- Four (4) Group 1 (ASME)
- Three (3) Group 2 (ASME)
- Three (3) Group A (ISO)
- Three (3) Group B/C (ISO)

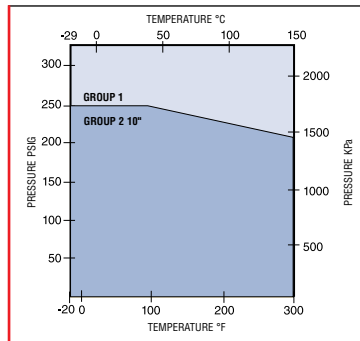

Operating Parameters

- Flows to 135 m³/h (600 gpm)
- Heads to 145 m (480 ft)
- Pressures to 17 bar (250 psi)
- Temperatures from -30°C (-20°F) to 150°C (300°F)

M-Series ASME Range Chart

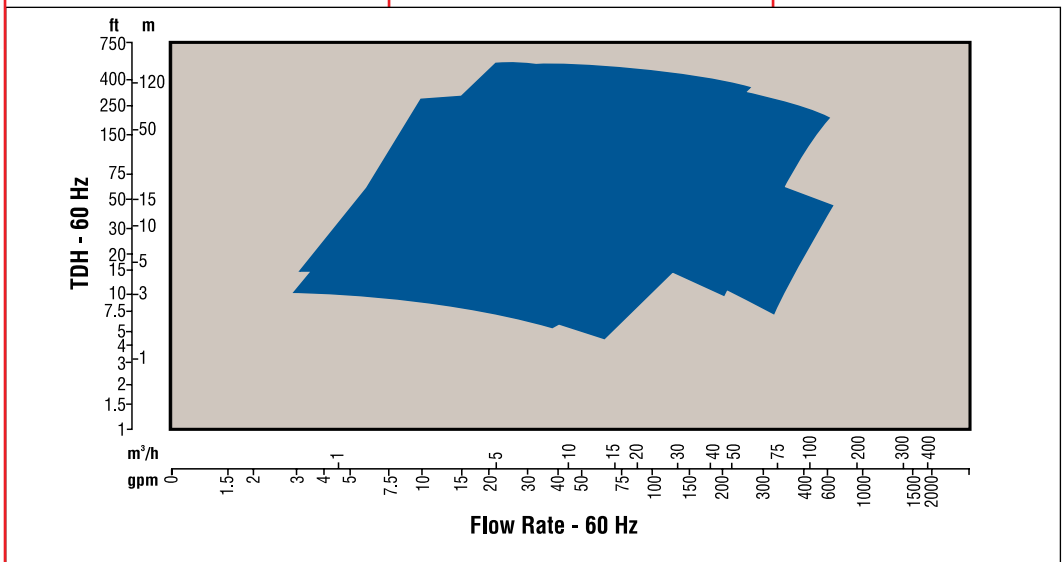

M-Series ISO Range Chart

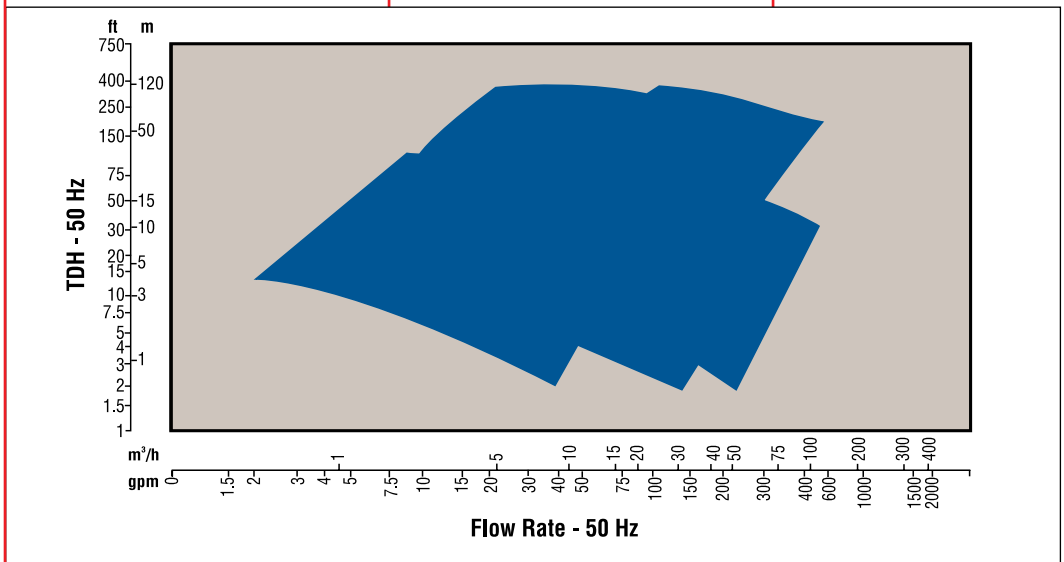

**PolyChem S-Series
Fluoropolymer Lined
Mechanically Sealed
Pumps**

**Revolutionary Non-Metallic
Pump Technology**

Flowserve fluoropolymer lined sealed pumps offer outstanding performance and significant economy in highly corrosive applications. Incorporating the proven Mark 3 power end, PolyChem S-Series pumps are engineered to maximize performance and reliability.

Addressing customer needs around the globe, PolyChem S-Series pumps meet the following dimensional standards:

- ASME B73.1
- ISO 2858/5199
- JIS drilling

Operating Parameters

- Flows to 420 m³/h (1850 gpm)
- Heads to 145 m (480 ft)
- Pressures to 17 bar (250 psi)
- Temperatures from -30°C (-20°F) to 150°C (300°F)

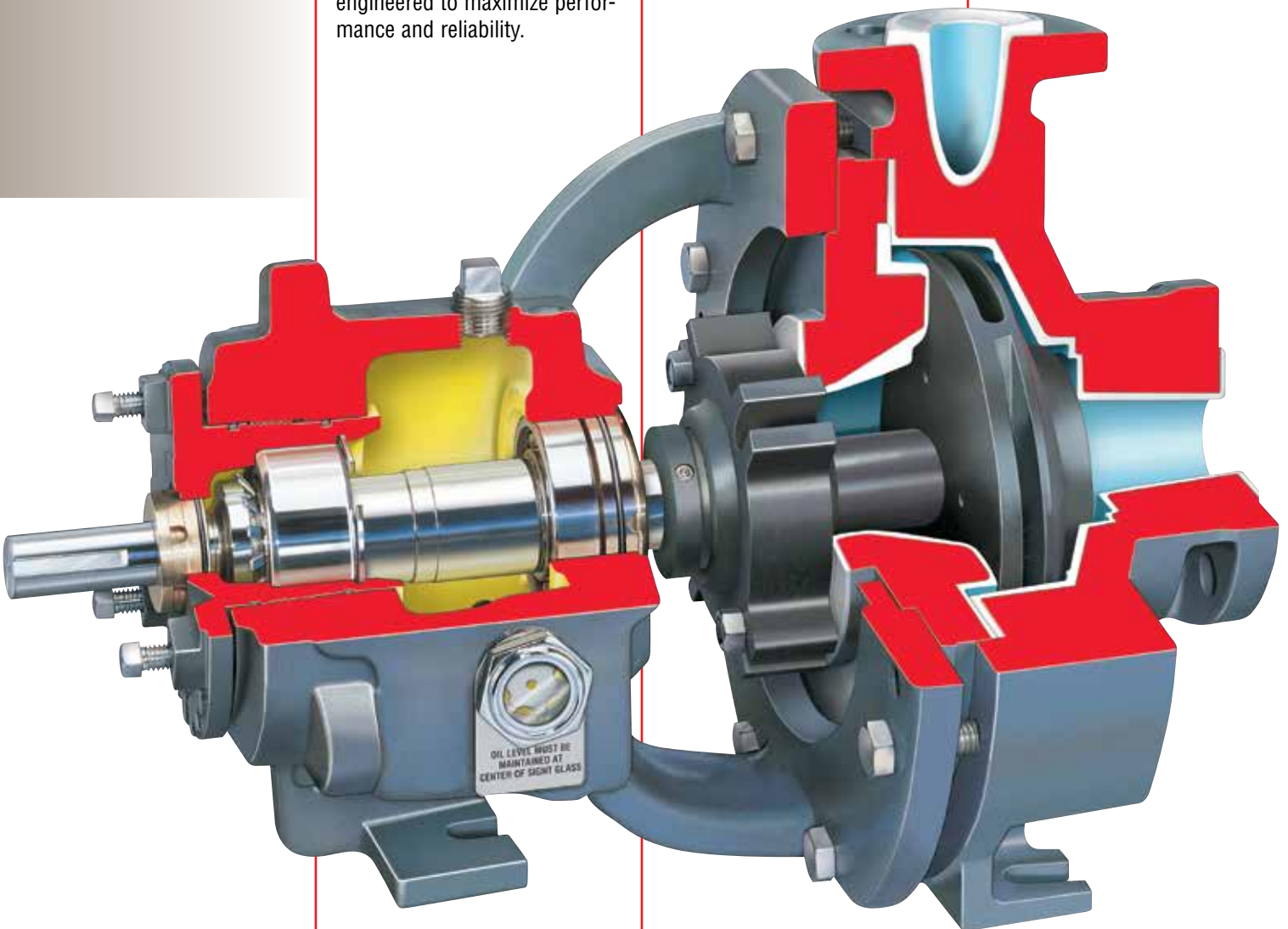

External Micrometer Impeller Adjustment accurately sets impeller in 20 seconds. Furthermore, mechanical seals and all critical settings can be set accurately in the shop.

Fluoropolymer PFA Lined Wet End is globally preferred for its superior corrosion resistance and temperature allowance.

Enclosed Impeller, through 250 mm (10 in), provides balanced hydraulic loads, extending bearing life. Open impeller available.

Clean Room Assembly of optional ANSI 3A™ power end (shown here) ensures optimum lubrication environment. Mark 3 power end is standard.

Silicon Carbide Shaft Sleeve mitigates corrosion and wear.

Seal Chamber with large tapered bore accommodates multiple seal selections. (See page 12 for typical seal arrangements.)

Advanced FM SealSentry™ Design Technology

Only Flowserve offers a non-metallic pump with the advantages of an oversized seal chamber with flow modifiers.

- Self-flushing
- Self-venting
- Self-draining

Seal life is extended due to superior purging of heat, solids and vapors. Costs are reduced because single seals often can be selected where dual seals or external flush and throat bushing combinations had been necessary.



Available open impeller

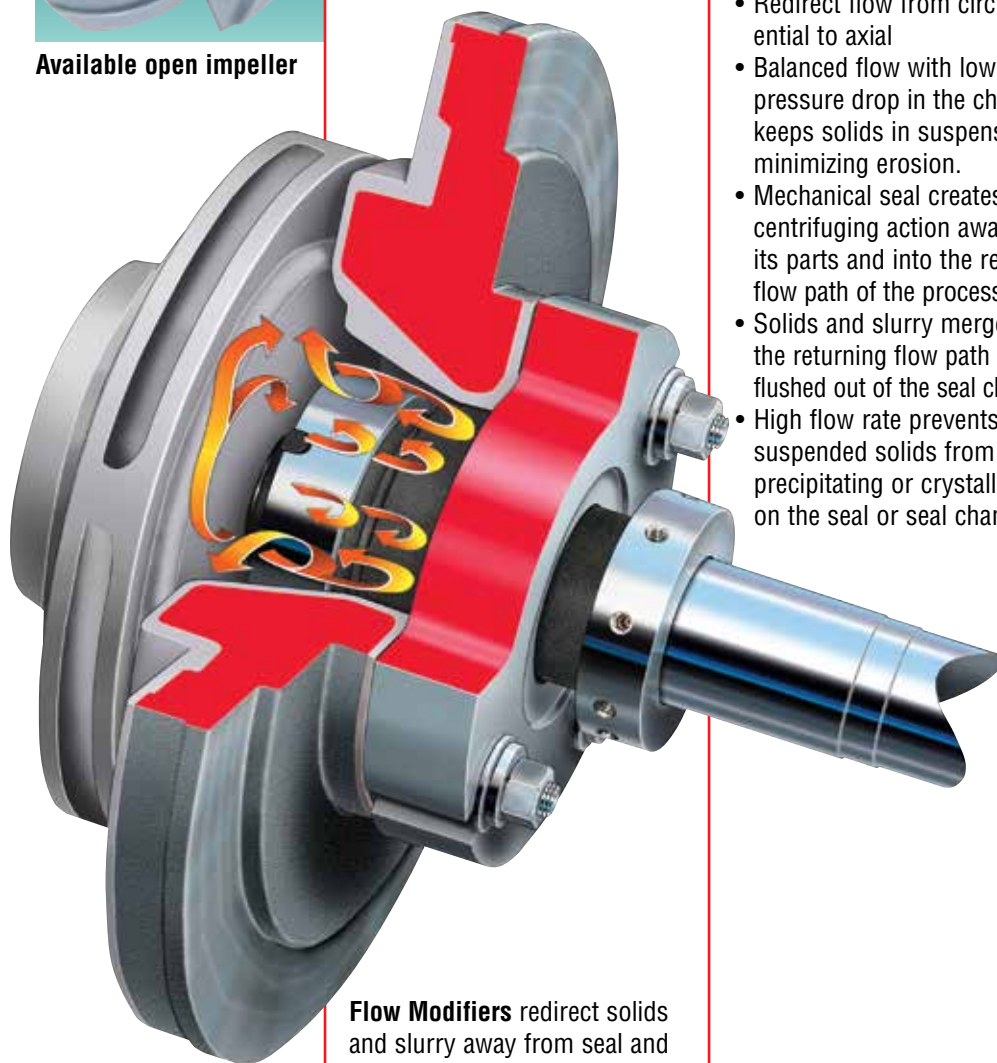

Flow Modifiers redirect solids and slurry away from seal and back into the flow path of the process liquid.

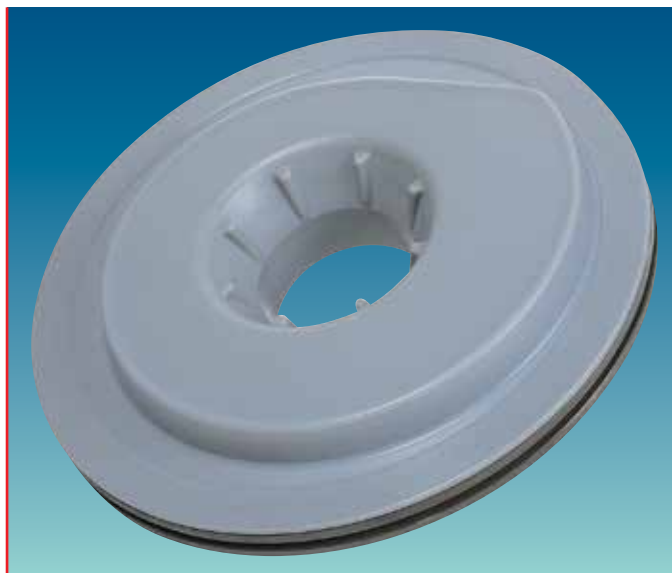

Flow Modifiers Extend Mechanical Seal Life

- Redirect flow from circumferential to axial
- Balanced flow with low pressure drop in the chamber keeps solids in suspension, minimizing erosion.
- Mechanical seal creates a centrifuging action away from its parts and into the returning flow path of the process liquid.
- Solids and slurry merge into the returning flow path and are flushed out of the seal chamber.
- High flow rate prevents suspended solids from precipitating or crystallizing on the seal or seal chamber.

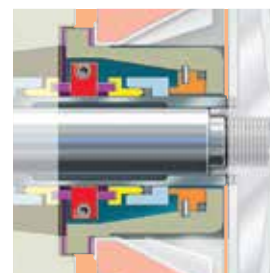

Unique Seal Chamber Canister allows double component seals to be applied in the FM seal chamber. This canister enables quick retrofits and eliminates the need to stock additional rear covers.

Choice of Power Ends

- Standard Mark 3A power end
- Optional ANSI 3A™ power end (shown on page 10) with lifetime warranty, features Inpro/Seal's VBXX bearing isolators

Power End Options

- Alloy shaft sleeves
- Solid shafts
- Labyrinth seals
- Magnetic drain plug
- Oil slinger
- Regreasable or double-shielded bearings
- Oil mist system

***PolyChem S-Series
Fluoropolymer Lined
Mechanically Sealed
Pumps***

Sealing Options

PolyChem S-Series pumps offer the advantage of innovative and readily available seal selections. Shown here are standard and recommended seal arrangements.

Non-Metallic Single Cartridge

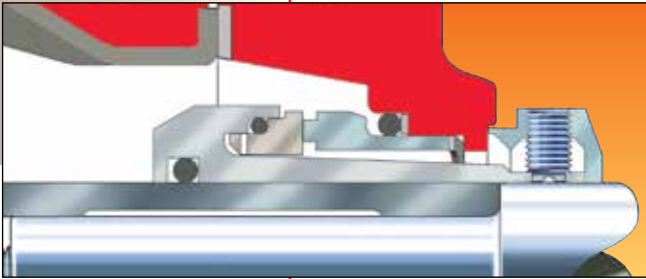

Non-Metallic Single External

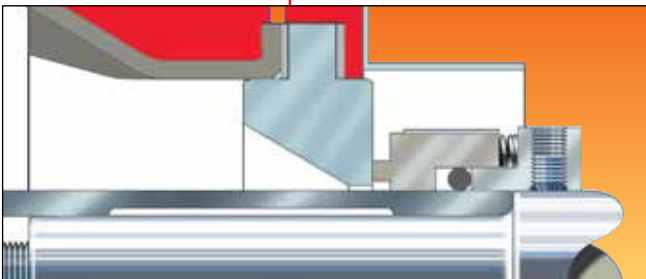

Metallic Single Cartridge

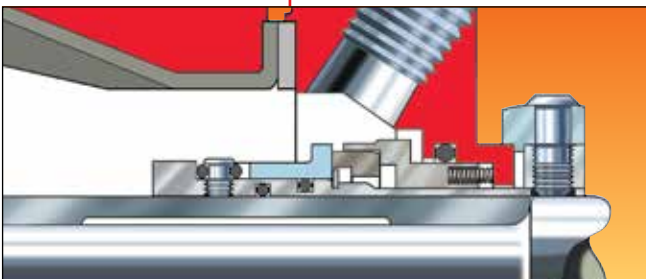

Metallic Single Component

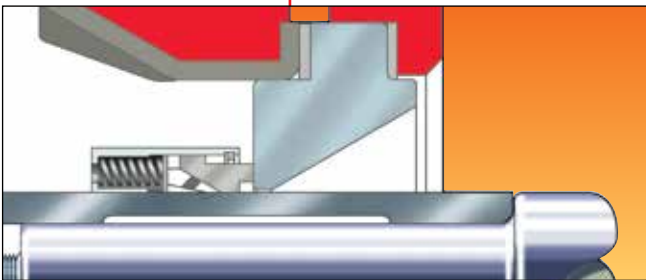

Double Component (Collar Drive)

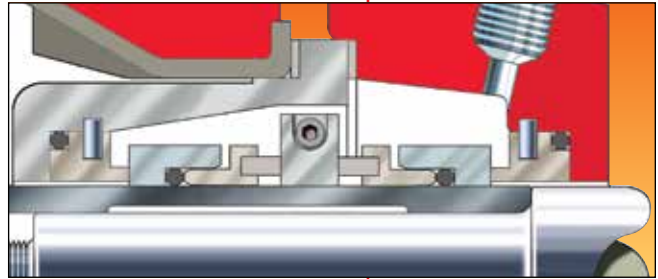

Double Component (Friction Drive)

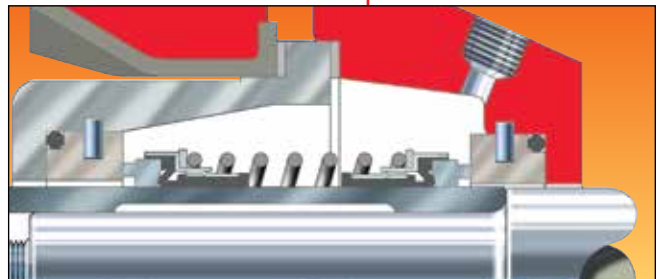

Non-Metallic Double Cartridge

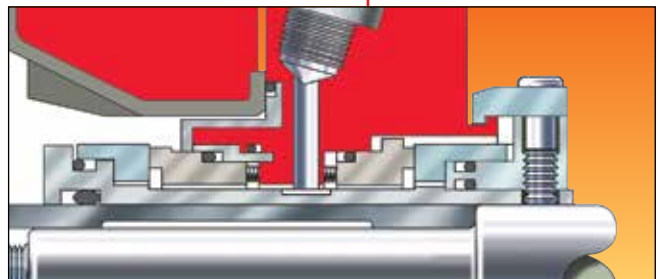

Metallic Double Cartridge

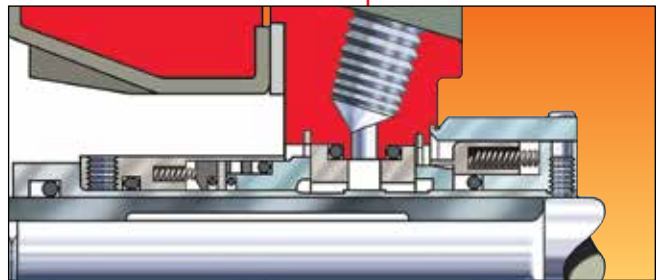

**PolyChem
S-Series
Performance
Curves**

PolyChem S-Series sealed pumps cover a broad hydraulic range.

Nineteen Sizes

- Four (4) Group 1 (ASME)
- Six (6) Group 2 (ASME)
- Three (3) Group A (ISO)
- Six (6) Group B/C (ISO)

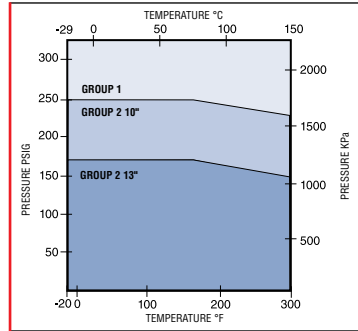

Operating Parameters

- Flows to 420 m³/h (1850 gpm)
- Heads to 145 m (480 ft)
- Pressures to 17 bar (250 psi)
- Temperatures from -30°C (-20°F) to 150°C (300°F)

S-Series ASME Range Chart

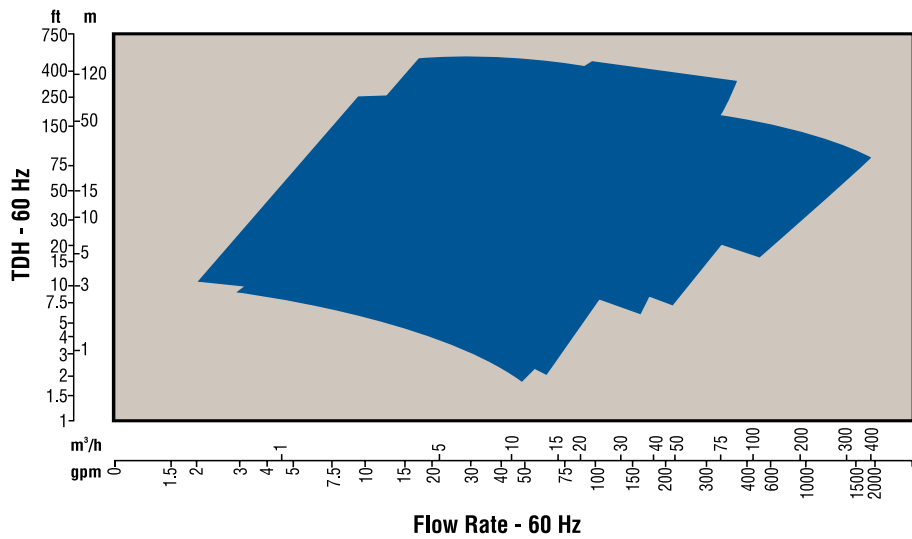

S-Series ISO Range Chart

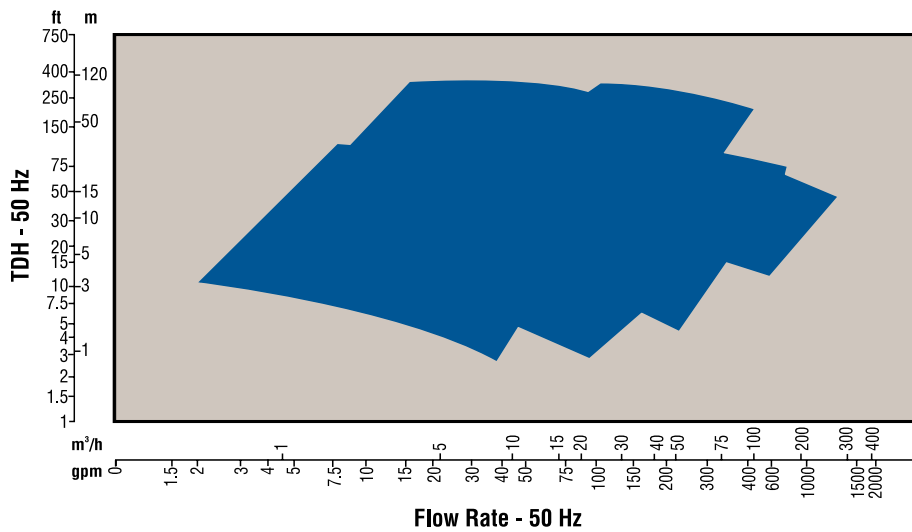

**PolyChem GRP
Engineered
Composite
ANSI Pumps**

The Low-Cost, Long-Term Solution to Corrosive Services
The PolyChem GRP engineered composite pump is the result of intensive product development and installation experience. Made of premium Derakane® vinyl ester resin reinforced with randomly oriented glass fibers, the GRP pump is designed to

ASME B73.5M standards for chemical process pumps.
With corrosion resistance superior to many more expensive, highly alloyed metals and with costs closer to that of ductile iron, the PolyChem GRP has proven to be the low-cost, long-term solution in acidic and chloride-rich applications.

- Operating Parameters**
- Flows to 2050 m³/h (9000 gpm)
 - Heads to 150 m (500 ft)
 - Pressures to 17 bar (250 psi)
 - Temperatures from -45°C (-50°F) to 120°C (250°F)

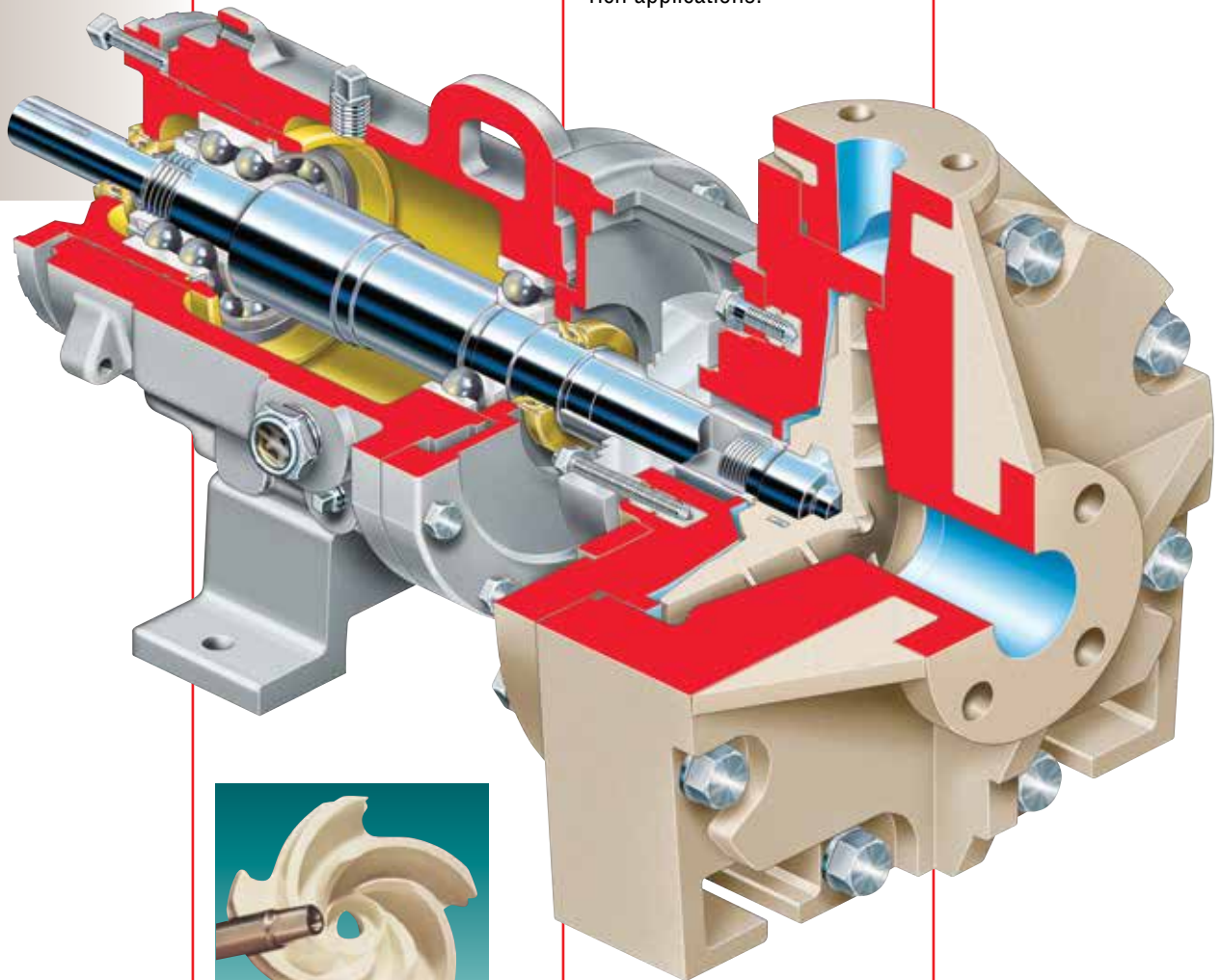

Engineered Composite Material Construction offers cost-effective corrosion resistance and is lightweight, non-galling, non-sparking and non-conductive.

Tapered Polygon Impeller Drive provides exceptional torque carrying ability and unequalled shear strength for durability.

Externally Adjustable, Semi-open Impeller is inherently balanced and provides consistently high efficiencies.

Centerline Discharge Casing with integrally molded flanges is fully gusseted for optimal nozzle loading capabilities.

Standard Mark 3 Power End with double lip oil seals and top vent breather

Low-cost, Non-metallic Replaceable Sleeve mitigates shaft corrosion.

Radial Fit and Square O-rings for the casing and impeller, respectively, protect the shaft from corrosive liquids.

Flexible Spacer-type Couplings permit disassembly without disturbing the piping, driver or alignment.

© Derakane is a registered trademark of Dow Chemical Company.



Compression Molded

GRP wet end components are compression molded at high temperatures and pressures to evenly distribute reinforcing fibers. This results in:

- Smooth hydraulic passages
- High efficiencies
- Lower operating costs
- High structural strength

Stuffing Box Options

Four stuffing boxes are available to maximize seal or packing life.

- Standard box with clamped seat gland accepts all types of single outside seals.
- Standard box with long gland accepts all types of inside seals, including single and double seals.
- Packing box extension
- Taper bore box

Self-Priming Option

Made of a proprietary glass fiber reinforced thermosetting epoxy resin, the self-priming pump is built to ASME B73.1 dimensions. It is an excellent choice for corrosive applications such as:

- Industrial sumps
- Waste treatment pond transfer
- Tank car unloading
- Lift stations

Operating Parameters

- Flows to 115 m³/h (500 gpm)
- Heads to 115 m (375 ft)

Typical GRP Seal Arrangements

Seal Types	Unbalanced	Balanced
Single outside with clamped seats	Multiple spring, O-ring mounted	—
	Bellows, O-ring mounted	—
Double	Friction drive	—
	Multiple spring, O-ring mounted	—
	Multiple spring, PTFE mounted	—
Single inside with flexible seats	Single spring, elastomer bellows	
	Single spring, O-ring mounted	
	Multiple spring, PTFE mounted	
		Metal bellows, O-ring mounted
Single inside, cartridge	Multiple spring, O-ring mounted	
		Metal bellows, O-ring mounted
Double/tandem, cartridge	Multiple spring, O-ring mounted	
		Metal bellows, O-ring mounted

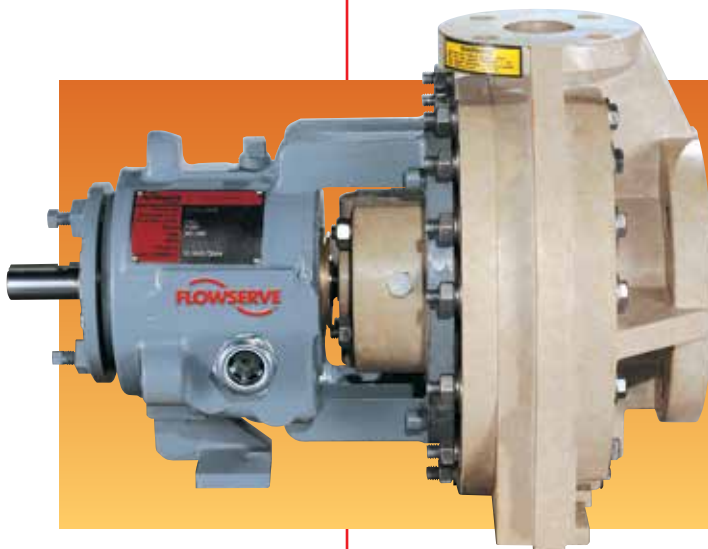

ANSI 3A Power End is so advanced it carries a lifetime warranty.

- Certified clean room assembly
- Inpro/Seal's VBXX® non-contact Vapor Block Bearing Isolator keeps lubricants in and contaminants out
- Magnetic drain plug
- Top vent replaced with plug
- Lubrication options

© VBXX is a registered trademark of Inpro Companies.

**PolyChem VGRP
Engineered
Composite
ANSI Pumps**

The PolyChem VGRP is a fiberglass, vertical immersion, open impeller pump designed for corrosive wet-pit applications in waste handling and chemical transfer.

VGRP Operating Parameters

- Flows to 565 m³/h (2500 gpm)
- Heads to 110 m (350 ft)
- Pressures to 17 bar (250 psi)
- Temperatures from -30°C (-20°F) to 90°C (200°F)
- Pit depths to 4.25 m (14 ft); 6.75 m (22 ft) with optional tailpipe

Unique Single-piece Fiberglass Column is generously sized for strength and rigidity. Available in 0.6 m (2 ft) to 4.3 m (14 ft) lengths.

Shaft and Bearing System operates well below the first critical speed, resulting in less shaft whip and longer bearing life. Meets API bearing span requirements.

Bearings can be lubricated by external flush, or self-lubricated by the pump fluid.

Pull-out Bearing Retainer streamlines maintenance.

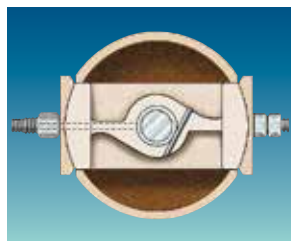

Pull-out Bearing Retainer

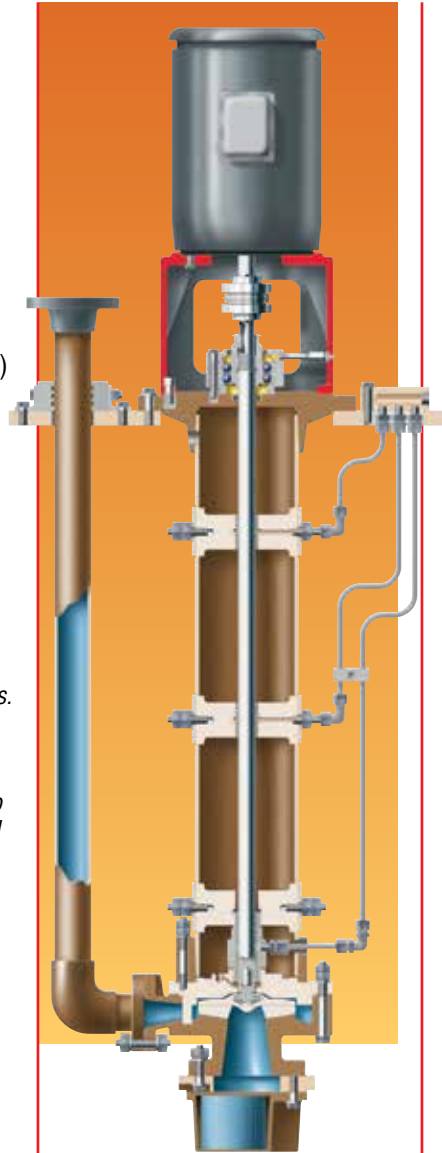

Features

- C-Face NEMA motors
- API bearing spacing
- Integral double row thrust bearings
- Fiberglass mounting plate
- Single connection for bearing lubrication
- Vapor-sealed thrust bearing

Options

- Simplex and duplex pit covers
- Float switches
- 316 SS, Alloy 20, Hastelloy® or titanium alloy shafts
- Particulate separators for dirty product lubrication
- Non-metallic lubrication lines
- Tailpipe

© Hastelloy is a registered trademark of Haynes International, Inc.

PolyChem GRP and VGRP Performance Curves

GRP

Sixteen Sizes

- Four (4) Group 1
- Nine (9) Group 2
- Two (2) Group 3
- One (1) Group 4

GRP

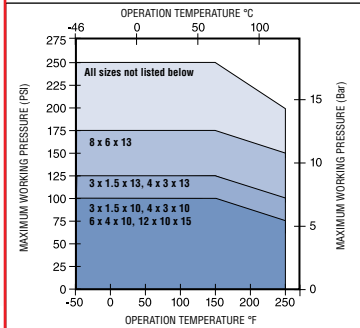

VGRP

Fourteen Sizes

- Four (4) Group 1
- Nine (9) Group 2
- One (1) Group 3

VGRP

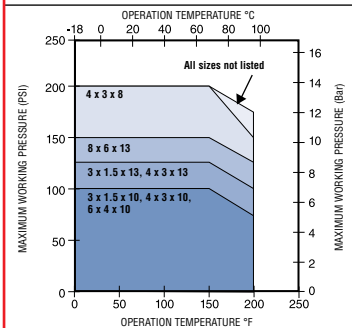

GRP Operating Parameters

- Flows to 2050 m³/h (9000 gpm)
- Heads to 150 m (500 ft)
- Pressures to 17 bar (250 psi)
- Temperatures from -45°C (-50°F) to 120°C (250°F)

GRP Range Chart

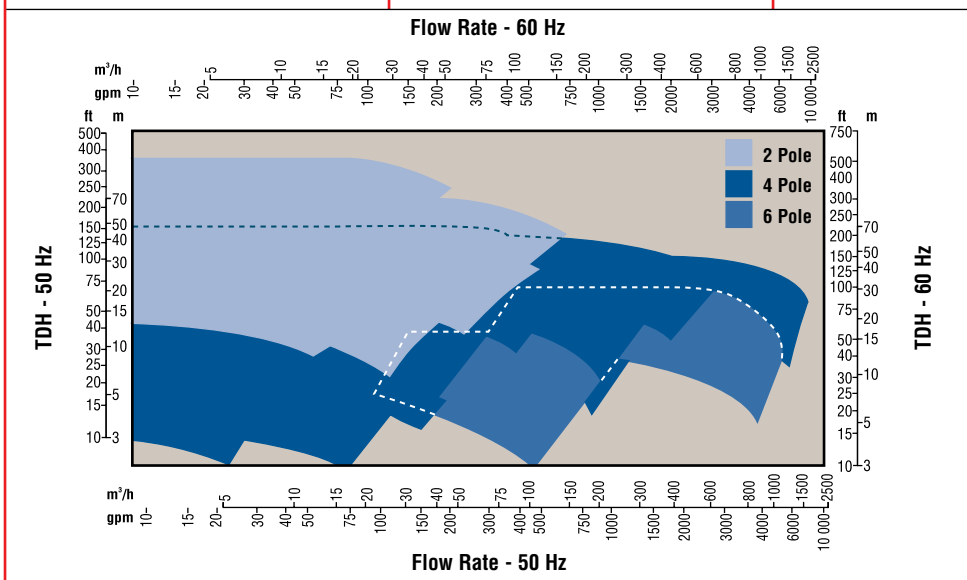

VGRP Range Chart

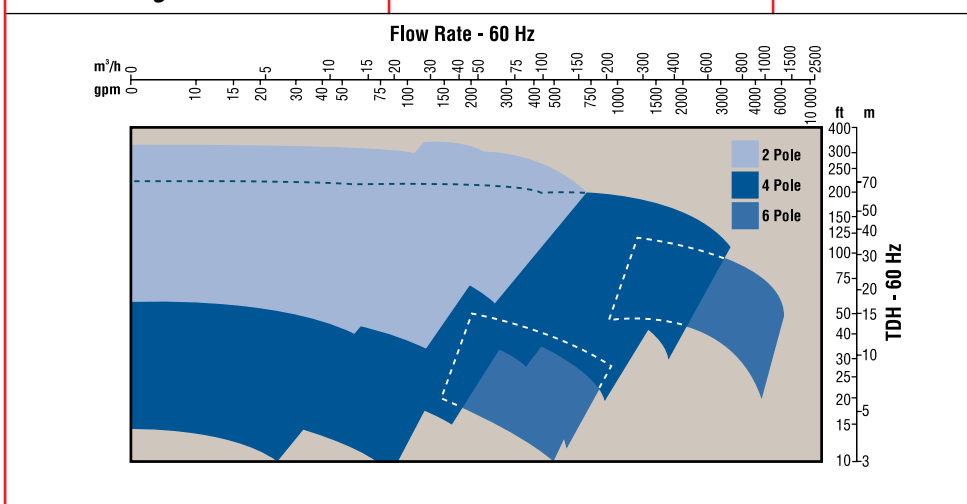

Pre-Engineered Baseplate Designs

Extend Pump Life and Reduce Maintenance Costs

The Flowserve family of pre-engineered baseplates further extends pump life by reducing internal stress and vibrations. That is why Flowserve recommends reinforced rigid baseplates.

Flowserve offers a broad range of metallic and non-metallic, grout and stilt mounted designs with standard options. This provides flexibility in choosing the baseplate that best meets application needs and operating budget.

Standard steel baseplate

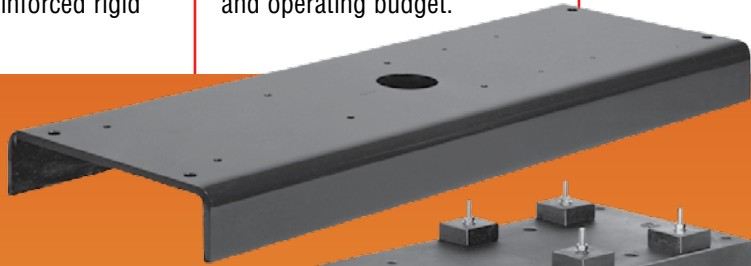

PolyBase™ baseplate

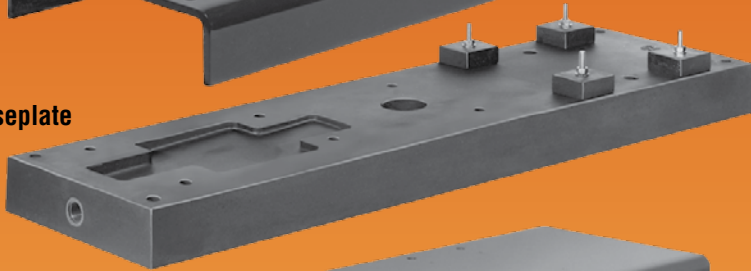

Reinforced baseplate – stilt mounted

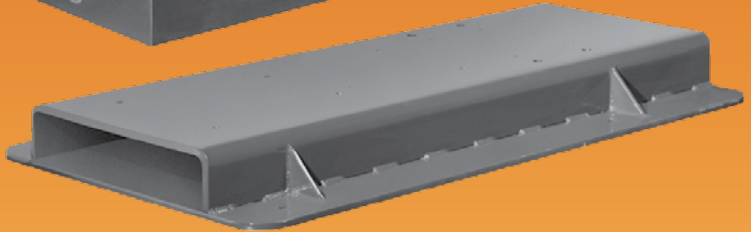

Reinforced baseplate – foundation mounted

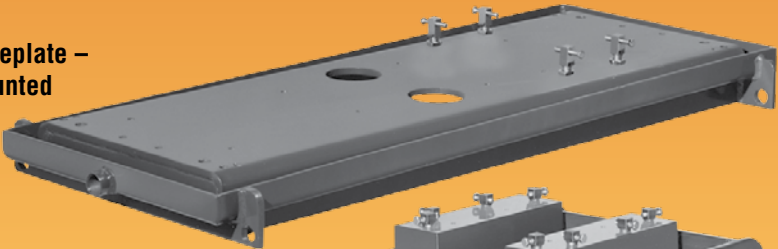

Heavy-duty, foundation mounted

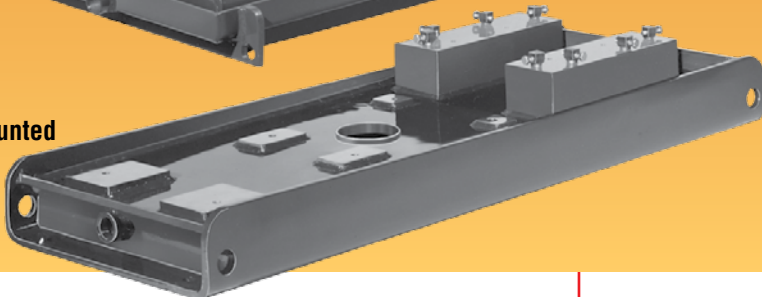

Baseplate Materials

- Steel
- Rolled steel
- Stainless steel
- Polymer concrete

Baseplate Options

- Stilt mounting
- Spring mounting
- Drain rims, pans and connections
- Polycrrete mounts
- Motor feet adjusters
- Earthing points

Polybase – Polymer Concrete Baseplate

- Low installed cost
- Superior vibration dampening
- Corrosion resistant
- Superior resistance to twisting or diaphragming
- Optional catch basin and grout holes
- Inserts to mount alternate equipment configuration requirements

***Polyshield
Polymer
Baseplate and
Foundation
System***

The **Polyshield Baseplate and Foundation System** is the superior solution for cost-effective, high performance pump installation. In one complete unit it combines a traditional baseplate with a formed concrete foundation for pump-drive sets.

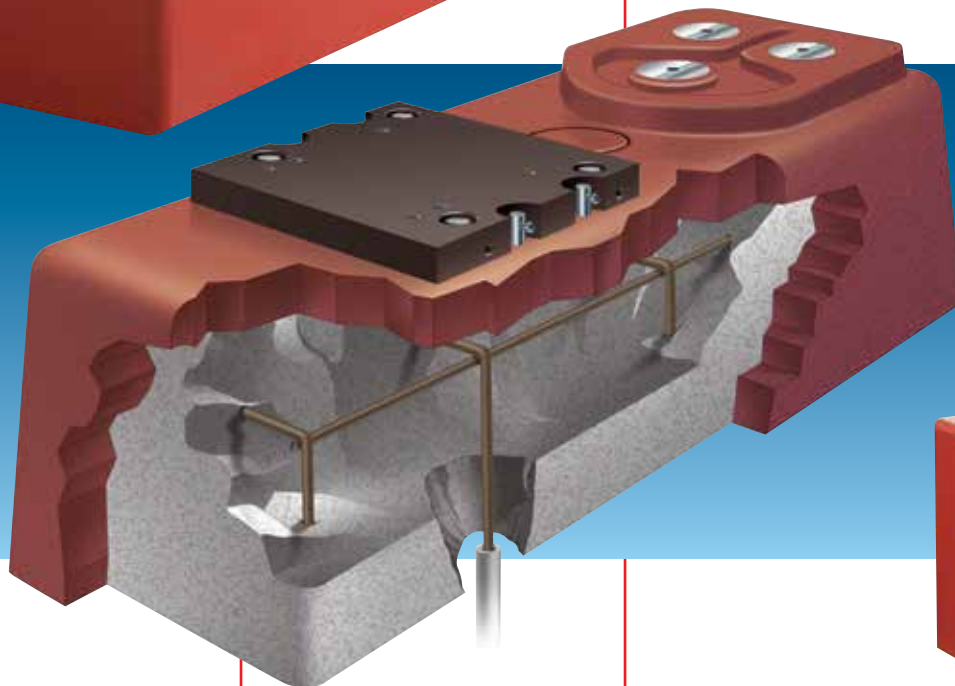

Benefits of Selecting the Polyshield Baseplate and Foundation System

- Time savings
 - Quick installation time
 - Reduces time span from receipt at job site to commissioning
- Cost savings
 - Reduces total installed cost
 - Dramatically minimizes field rework necessary to meet specifications
- Better performance and reliability
 - Extended pump life
 - Reduced vibration
 - Improved corrosion resistance
- Single structure convenience
 - One-piece construction
 - Flat mounting surfaces
 - One-piece motor mounting block

The Polyshield baseplate and foundation system can be combined with numerous pump designs, including:

- ISO and ASME metallic and non-metallic
- Foot- and frame-mounted general industrial
- Foot-mounted between bearing
- ISO 13709/API 610

Please see Bulletin PS-90-2 for more complete product information.



Pump Accessories

ClearGuard and DurcoShield Non-Metallic Safety Guards

ClearGuard and DurcoShield pump guards permit visual inspection of coupling and seal areas, respectively, while protecting personnel from potential safety hazards of rotating parts. Constructed of durable and transparent polycarbonate with UV light inhibitors, they are designed to withstand tough chemical processing environments.

DurcoShield splash and shaft guard is a one-piece shield that envelops the open areas between the bearing housing and casing. Suitable for applications to 150°C (300°F), DurcoShield protects from:

- Process fluid spray
- Rotating shaft and seal components

ClearGuard meets machinery guard safety guidelines. Nothing larger than 6 mm (0.24 in) in diameter can enter the shell. Furthermore, the ability to inspect the coupling through ClearGuard can provide early warning of deteriorating or malfunctioning components.



The KW941 Pump Power Monitor monitors and displays actual power to the pump, offering simultaneous protection from underload and overload operating conditions.

The KW941 helps to eliminate costly downtime and expensive pump repairs caused by:

- Dry running
- Pump overloads
- Cavitation
- Blocked lines
- Closed suction or discharge valves
- Excessive wear or rubbing



CPXS and Guardian Magnetic Drive Pumps

Durco® Mark 3™ ISO Chemical Process Pump

CPXS and Guardian® Magnetically Driven Pumps

Flowserve offers highly reliable magnetically driven pumps to both ASME and ISO specifications. The CPXS (ISO) and Guardian (ASME) pumps are ideal for emission-free service requirements.

Operating Parameters

- Flows to 420 m³/h (1850 gpm)
- Heads to 215 m (700 ft)
- Pressures to 25 bar (365 psi)
- High temperatures design to 290°C (550°F)

Please see Bulletin PS-10-14 for more information on the Guardian and Bulletin PS-10-31 for more information on the CPXS.

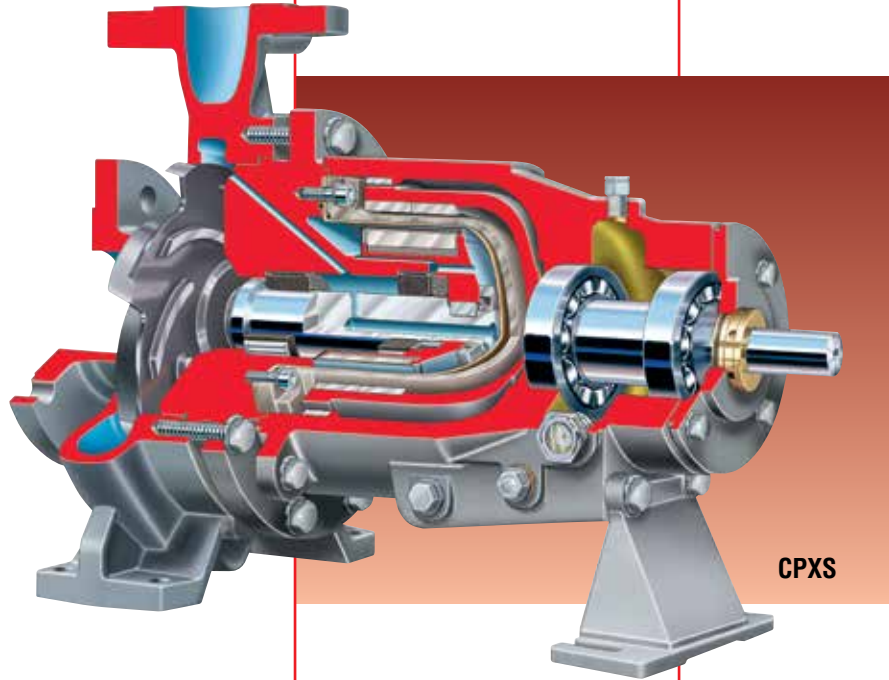

CPXS

Durco Mark 3 ISO Chemical Process Pump

Offering state-of-the-art hydraulics, the Durco Mark 3 ISO pump is designed for chemical process applications in which high performance, high efficiency and low NPSH are required.

Conforming to ISO 2858 and ISO 5199 design criteria, the Durco Mark 3 ISO is CE marked and compliant with applicable European directives, such as ATEX.

Operating Parameters

- Flows to 1400 m³/h (6160 gpm)
- Heads to 220 m (720 ft)
- Pressures to 25 bar (365 psi)
- Temperatures from -80°C (-110°F) to 400°C (752°F)

Please see Bulletin PS-10-31 for more complete product information.

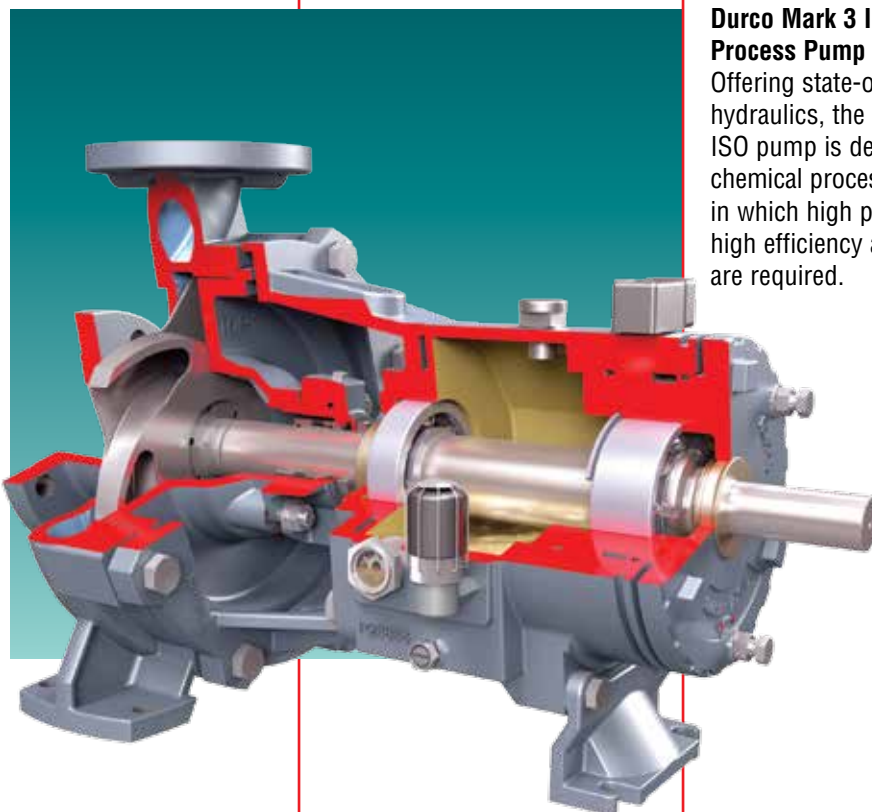

**Durco Mark 3 ASME
Standard and
In-Line Pumps**

Durco Mark 3
With its reverse vane impeller, SealSentry family of seal chambers, and the optional ANSI 3A power end, the Durco Mark 3 Standard pump is recognized worldwide as the premier name in ASME chemical process pumps.

Thirty Sizes

- Seven (7) Group 1
- Sixteen (16) Group 2
- Seven (7) Group 3

Operating Parameters

- Flows to 1680 m³/h (7400 gpm)
- Heads to 215 m (700 ft)
- Pressures to 27 bar (400 psi)
- Temperatures from -75°C (-100°F) to 370°C (700°F)

Please see Bulletin PS-10-13 for more complete product information.

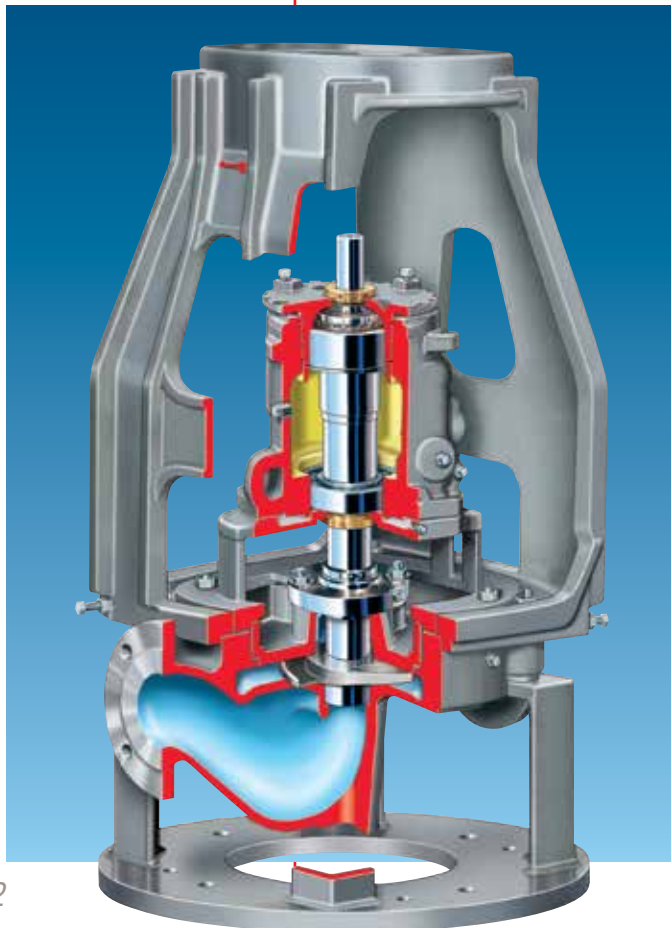
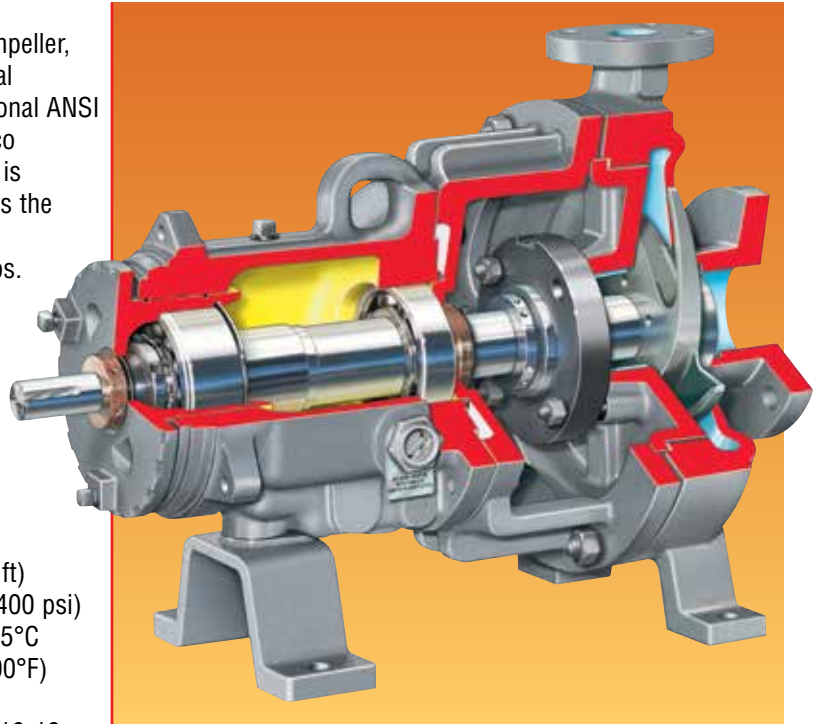

Durco Mark 3 In-Line

Designed to exceed ASME B73.2 criteria, the Mark 3 In-Line process pump offers improved reliability and extended pump life. The space-saving Mark 3 In-Line has broad application in chemical and hydrocarbon processing as well as in general industry. With its own independent bearing housing and rigid C-flange style motor adapter, the Mark 3 In-Line remains one of the most reliable process pump designs available.

Operating Parameters

- Flows to 370 m³/h (1630 gpm)
- Heads to 230 m (760 ft)
- Pressures to 24 bar (350 psi)
- Temperatures to 370°C (700°F)

Please see Bulletin PS-10-15 for more complete product information.

**Global
Engineered Services
and Support**

- Total Cost Reduction*
- Asset Management*
- Product Life Cycle*
- Performance Re-rates*
- Site Diagnostics*
- Repair Services*
- Energy Management*
- Spare Parts*
- Maintenance Contracts*
- Materials Upgrades*
- Turnkey Services*
- Field Repairs*
- Installation*
- Project Supervision*
- Commissioning*
- Equipment Upgrades*
- Condition Monitoring*
- Systems Analysis*
- Field Machining*

Service Dedication

Flowserve Engineered Services is focused on providing customers with uncompromising service and support, where and when needed. Dedicated to delivering the highest quality support, Engineered Services integrates its extensive pump and materials engineering knowledge with creative service solutions. Engineered Services fully understands the business challenges facing customers and is prepared to manage solutions to succeed as a team.

A worldwide network of service and repair centers staffed by highly skilled engineers and technicians is available around the clock, seven days a week to respond to customer queries, evaluate and troubleshoot problems, and provide reliable solutions.



**Strength of Experience,
Commitment to Excellence**

Flowserve has long served industries requiring superior equipment performance and service life.

- Oil and gas production
- Hydrocarbon processing
- Chemical processing
- Water resources
- Power generation
- Nuclear
- Mining and mineral processing
- Pulp and paper
- General industry

Engineered Services is dedicated to maximizing equipment performance and providing reliability-centered maintenance programs for pumps and related equipment, regardless of manufacturer. Using the FlowStar™ asset management software, Engineered Services tracks performance and supports improvement programs using a service life cycle cost business approach. The results are improved reliability and increased profitability.

Business Partner

Flowserve partners with customers to respond to the dynamic business conditions that affect them. Flowserve will work with customers to drive efficiency, maximize throughput and control process quality. Whether user needs involve on-site technical assistance or broader project planning with full turnkey responsibility, Flowserve Engineered Services will deliver professional, reliable results.

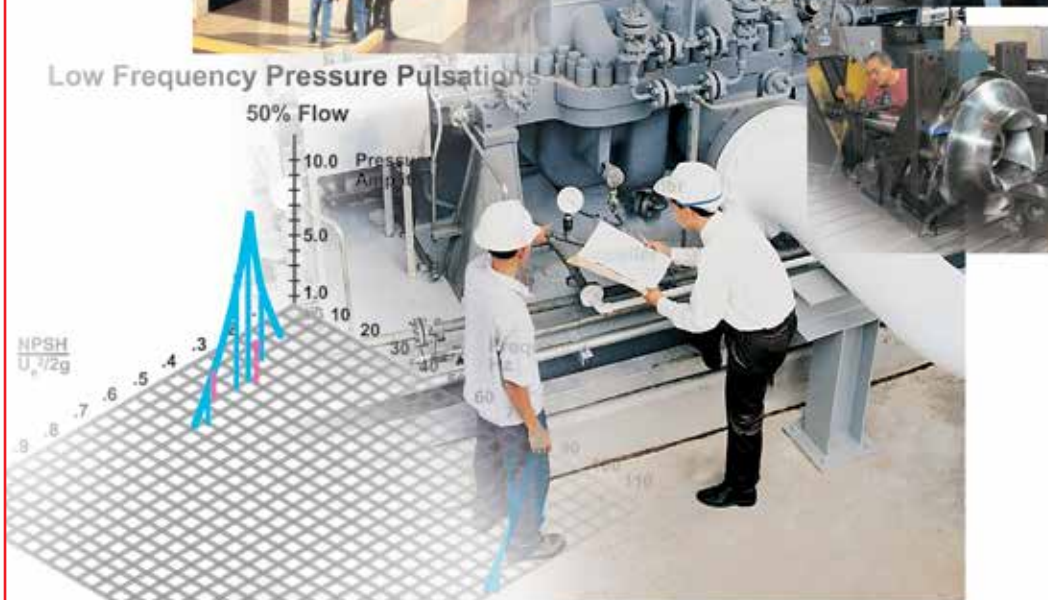

**FlowsERVE... Supporting Our Customers
With The World's Leading
Pump Brands**



Cameron™

Pleuger®

Durco®

Niigata Worthington™

TKL™

IDP®

Pacific®

Scienco™

Byron Jackson®

Worthington Simpson™

FlowsERVE®

Calder™ Energy Recovery Devices

Lawrence Pumps®

Worthington®

Sier-Bath®

United Centrifugal™

Western Land Roller™

Wilson-Snyder®

Aldrich™

ACEC™

USA and Canada

FlowsERVE Corporation
5215 North O'Connor Blvd.
Suite 2300
Irving, Texas 75039-5421 USA
Telephone: +1 937 890 5839

Europe, Middle East, Africa

FlowsERVE Corporation
Parallelweg 13
4878 AH Etten-Leur
The Netherlands
Telephone: +31 76 502 8100



Your local FlowsERVE representative:

**To find your local FlowsERVE representative,
please use the Sales Support Locator System
found at www.flowsERVE.com
or call: +1 937 890 5839.**

Latin America

FlowsERVE Corporation
Martín Rodríguez 4460
B1644CGN-Victoria-San Fernando
Buenos Aires, Argentina
Telephone: +54 11 4006 8700
Telefax: +54 11 4714 1610

Asia Pacific

FlowsERVE Pte. Ltd.
10 Tuas Loop
Singapore 637345
Telephone: +65 6771 0600
Telefax: +65 6862 2329