

# Displacer Type

## Installation and Operating Manual



*Liquid  
Level  
and  
Proof-er<sup>®</sup>  
Switches*

---

## Read this Manual Before Installing

This manual provides information on the External Cage Displacer Liquid Level Switch. It is important that all instructions are read carefully and followed in sequence. Detailed instructions are included in the Installation section of this manual.

## Conventions Used in this Manual

Certain conventions are used in this manual to convey specific types of information. General technical material, support data, and safety information are presented in narrative form. The following styles are used for notes, cautions, and warnings.

### Notes

Notes contain information that augments or clarifies an operating step. Notes do not normally contain actions. They follow the procedural steps to which they refer.

### Cautions

Cautions alert the technician to special conditions that could injure personnel, damage equipment, or reduce a component's mechanical integrity. Cautions are also used to alert the technician to unsafe practices or the need for special protective equipment or specific materials. In this manual, a caution box indicates a potentially hazardous situation which, if not avoided, may result in minor or moderate injury.

### Warnings

Warnings identify potentially dangerous situations or serious hazards. In this manual, a warning indicates an imminently hazardous situation which, if not avoided, could result in serious injury or death.

## Safety Messages

Follow all standard industry procedures for servicing electrical equipment when working with or around high voltage. Always shut off the power supply before touching any components.

**WARNING!** Explosion hazard. Do not connect or disconnect equipment unless power has been switched off or the area is known to be non-hazardous.

## Low Voltage Directive

For use in Installation Category II, Pollution Degree 2. If equipment is used in a manner not specified by the manufacturer, protection provided by the equipment may be impaired.

## Notice of Trademark, Copyright, and Limitations

Magnetrol & Magnetrol logotype and Proof-er are registered trademarks of Magnetrol International.

Copyright © 2018 Magnetrol International, Incorporated. All rights reserved.

Magnetrol reserves the right to make changes to the product described in this manual at any time without notice. Magnetrol makes no warranty with respect to the accuracy of the information in this manual.

## Warranty

All Magnetrol mechanical level and flow controls are warranted free of defects in materials or workmanship for five full years from the date of original factory shipment.

If returned within the warranty period; and, upon factory inspection of the control, the cause of the claim is determined to be covered under the warranty; then, Magnetrol will repair or replace the control at no cost to the purchaser (or owner) other than transportation.

Magnetrol shall not be liable for misapplication, labor claims, direct or consequential damage or expense arising from the installation or use of equipment. There are no other warranties expressed or implied, except special written warranties covering some Magnetrol products.

## Quality Assurance

The quality assurance system in place at Magnetrol guarantees the highest level of quality throughout the company. Magnetrol is committed to providing full customer satisfaction both in quality products and quality service.

The Magnetrol quality assurance system is registered to ISO 9001 affirming its commitment to known international quality standards providing the strongest assurance of product/service quality available.





# Displacer Type Liquid Level and Proof-er® Switches

## Table of Contents

<b>1.0 Introduction</b>	
1.1 Principle of Operation.....	4
1.1.1 Displacer Controls.....	4
1.2 Operating Cycle.....	4
1.3 Operating Cycle — Proof-er Control Option.....	4
<b>2.0 Installation</b>	
2.1 Unpacking.....	5
2.2 Mounting.....	5
2.3 Wiring.....	6
<b>3.0 Preventive Maintenance</b>	
3.1 Recommended Practice.....	8
3.1.1 Keep control clean.....	8
3.1.2 Inspect switch mechanisms, terminals, and connections monthly.....	8
3.2 What to avoid.....	9
<b>4.0 Reference Information</b>	
4.1 Troubleshooting.....	10
4.1.1 Check switch mechanism.....	10
4.1.2 Test control's performance.....	11
4.1.3 Proof-er.....	12
4.2 Agency Approvals.....	12
4.3 Specifications.....	13
4.3.1 Basic Electrical Ratings.....	13
4.3.2 Pressure/Temperature Ratings.....	13
4.3.3 Model A10 Dimensional Data and Actuating Levels.....	14
4.3.4 Model A15 Dimensional and Actuating Levels.....	15
4.3.5 Model B10 Dimensional Data.....	16
4.3.6 Model B10 Actuating Levels.....	17
4.3.7 Model B15 Dimensional Data.....	24
4.3.8 Model B15 Actuating Levels.....	25
4.3.9 Model C10 Dimensional Data.....	26
4.3.10 Model C10 Actuating Levels.....	27
4.3.11 Model C15 Dimensional Data.....	30
4.3.12 Model C15 Actuating Levels.....	31
4.3.13 Proof-er Dimensional Data.....	31
4.3.14 Proof-er Replacement Parts.....	32
4.4 Replacement Parts.....	33
4.4.1 Displacer Replacement Parts.....	33
4.5 Model Numbers.....	34
4.5.1 A10 & A15 Single Switch Models.....	34
4.5.2 B10 & B15 Dual Switch Models.....	36
4.5.3 C10 & C15 Triple Switch Models.....	38

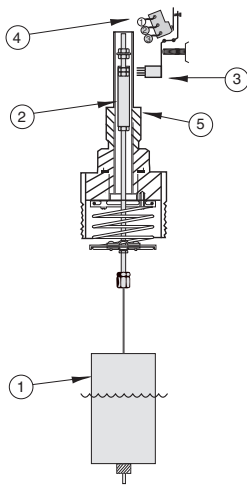
## 1.0 Introduction

Displacement type level switches offer the industrial user a wide choice of alarm and control configurations. These units utilize simple buoyancy principle and are well suited for simple or complex applications.

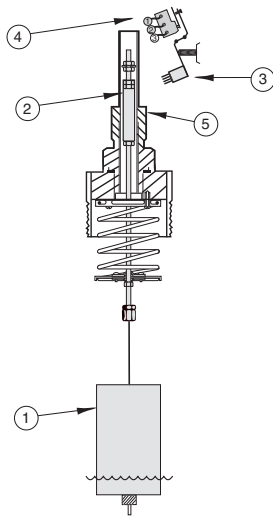
## 1.1 Principle of Operation

### 1.1.1 Displacer Controls

The design of displacer operated level switches is based upon the principle that a magnetic field will not be affected by non-magnetic materials such as 316 stainless steel. In this case, the displacer moves a magnetic attraction sleeve within a non-magnetic enclosing tube and actuates a magnetic switch mechanism. The enclosing tube provides a pressure seal to the chamber and, therefore, to the process.



**Figure 1**  
Switch position  
on rising level



**Figure 2**  
Switch position  
on falling level

## 1.2 Operating Cycle

A spring is loaded with a weighted displacer ① which is heavier than the liquid. Immersion of the displacers caused by rising liquid level imparts buoyancy forces on the displacer allowing the spring to compress. The attraction sleeve ② attached to the spring, moves upward into the field of a permanent magnet ③. The movement of the magnet toward the sleeve causes the switch ④ to actuate. A non-magnetic barrier tube ⑤ provides a static pressure boundary between the switch mechanism and the displacer assembly. As the liquid level falls, the displacer lowers, causing the spring to extend, and moving the attraction sleeve out of the magnetic field of the switch mechanism. This allows the switch to again change position and to break or make. See Figures 1 and 2.

## 1.3 Floating Roof Detection

The spring is loaded with a displacer weight suspended from a stainless steel cable. As the floating roof rises, the weight is lifted by the roof allowing the spring to compress, the attraction sleeve to move upward into the field of the switch magnet and the switch to actuate. As the roof lowers, the weight again hangs free causing the spring to extend, the sleeve to move downward and the switch to reset. The displacers are usually fabricated from ductile metals, such as brass, to prevent sparking when the displacer makes contact with the roof.

## 1.4 Operating Cycle — Proof-er Control Option

The purpose of the Proof-er is to check the operation of a displacer control without having to raise the level in the tank. This is accomplished by pulling downward on the Proof-er cable. This causes the spring loaded lever arm to lift the switch actuator, simulating a high or high-high level condition. When the cable is released, the Proof-er returns the actuator to its original position resuming normal operation.

---

## 2.0 Installation

**Caution:** If equipment is used in a manner not specified by manufacturer, protection provided by equipment may be impaired.

## 2.1 Unpacking

Top mounting displacer units are shipped from the factory with the displacer and cable assembly removed from the head assembly and packed separately in the same container.

**Caution:** If reshipping to another location, displacer assembly must again be removed from the control to prevent damage.

Unpack the instrument carefully. Inspect all units for damage. Report any concealed damage to carrier within 24 hours. Check the contents of the packing slip and purchase order. Check and record the serial number for future reference when ordering parts.

**Caution:** The threaded connection link and stem protruding from the head assembly are extremely fragile. DO NOT handle or place control in a position so that any amount of force is placed on the stem. Proper operation of the control requires that the stem is not damaged or bent.

**Caution:** Displacer spring and stem are fragile. DO NOT drop displacers into tank. Hand feed cable into position to avoid bending stem.

## 2.2 Mounting

**Caution:** This instrument is intended for use in Installation Category II, Pollution Degree 2.

Adjust the displacers on the displacer cable for the desired switch actuating levels (instruction tag is attached to cable). Screw displacer cable fitting to threaded connection link protruding from the underside of control.

Be sure there are no tubes, rods, or other obstacles in the tank or vessel to interfere with the operation of the displacers. No guides into the tank are necessary unless liquid turbulence is excessive, in which case a guide pipe or tube should be at least 1 inch larger than the displacer diameter, open at the bottom end, and with several vent holes located above the maximum high level of the liquid.

Check the installation of pipe or tube to be certain it is plumb.

**Caution:** Before attaching Magnetrol control to tank or vessel, using a level, check to see that tank mounting flange is within 3° of horizontal in all directions. Proper operation of the control depends on the switch housing being plumb.

For floating roof top applications, the displacer switch may be mounted via flange or threaded mounting on a bracket, catwalk, etc. or through an opening in an outer dome roof. Ensure that there are no obstacles to interfere with the operation of the displacers or weights and that there is a level surface on the roof beneath the displacer/weight.

**Caution:** Operation of all buoyancy type level devices should be done in such a way as to minimize the action of dynamic forces on the float or displacer sensing element. Good practice for reducing the likelihood of damage to the control is to equalize pressure across the device slowly.

## 2.3 Wiring

**Caution:** Level controls are shipped from the factory with the enclosing tube tightened and the middle set screw, on the housing base, locked to the enclosing tube. Failure to loosen the set screw prior to repositioning the conduit connection may cause the enclosing tube to loosen, resulting in the possible leakage of the process liquid or vapor.

**NOTE:** If control is equipped with pneumatic switch mechanism, disregard these instructions and refer to instruction bulletin on mechanism furnished for air (or gas) connections.

Most switch enclosures are designed to provide 360° positioning of the conduit outlet by loosening the set screw(s) located at the bottom of the switch housing base. To rotate conduit entry:

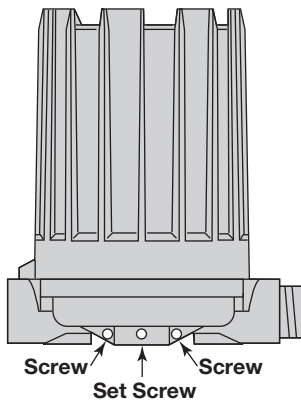
1. Loosen set screw(s) at base of switch housing. Refer to Figure 2.
2. Rotate switch housing so that conduit entry is positioned as desired.
3. Tighten set screws at base of housing.

At the factory, terminal blocks are positioned next to the conduit entry to facilitate wiring. If repositioning of the switch mechanisms is desired:

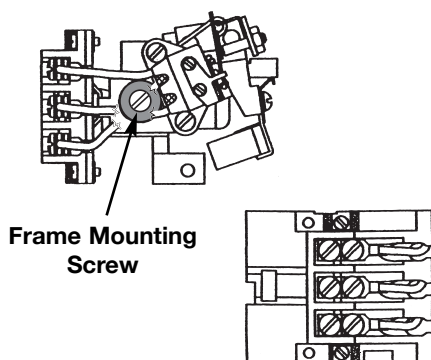
1. Unscrew and remove switch housing cover. The threads have been lubricated to facilitate removal.
2. Loosen the frame mounting screw on each switch mechanism. Refer to Figure 3.
3. Carefully rotate the baffle plate and all switch mechanisms together until the terminal blocks are in the desired position.

**NOTE:** On dual and triple stage controls the correct spacing of the mechanisms is maintained using brackets that connect the mechanisms. Take care when rotating the baffle plate and mechanisms to rotate them as a unit and not one at a time. This will ensure that the brackets and mechanisms will not be damaged during repositioning.

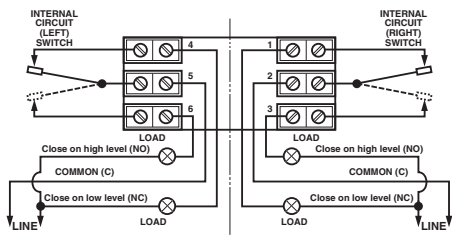
4. Ensure that the terminal blocks are aligned vertically to prevent stress on the brackets and mechanisms.
5. Tighten the frame mounting screw on each switch mechanism.



**Figure 2**  
NEMA 4X, NEMA 4X/7/9,  
NEMA 4X/7/9 Group B

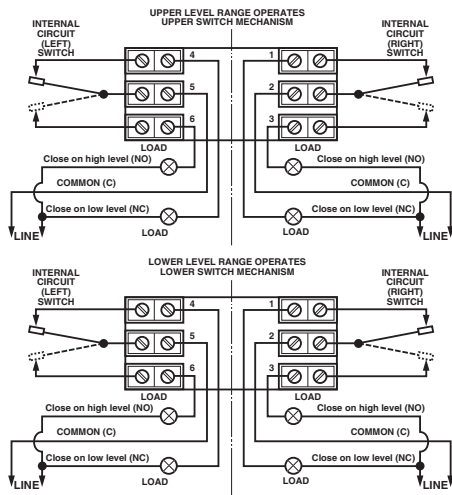


**Figure 3**  
Switch Mechanism



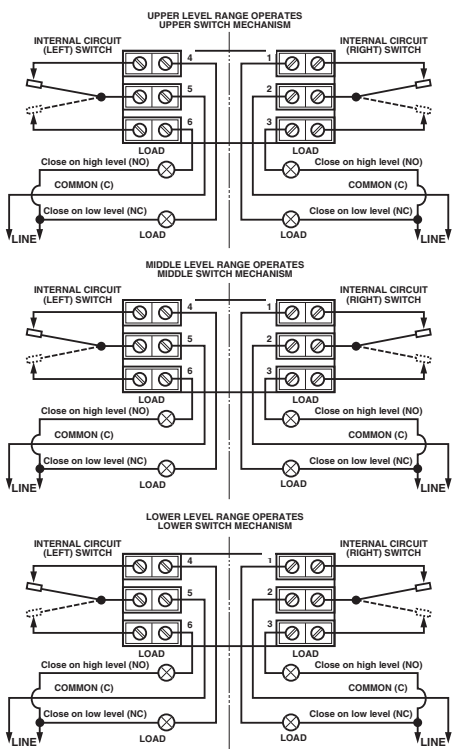
NOTES: 1. Double pole action is obtained by simultaneous operation of the right and left side single pole switches.  
 2. Rising Level Closes Contacts 5 & 6 and 2 & 3.  
 3. Falling Level Closes Contacts 4 & 5 and 1 & 2.

Figure 4 – Single Stage with DPDT contacts



NOTES: 1. Double pole action is obtained by simultaneous operation of the right and left side single pole switches.  
 2. Rising Level Closes Contacts 5 & 6 and 2 & 3.  
 3. Falling Level Closes Contacts 4 & 5 and 1 & 2.

Figure 5 – Dual Stage with DPDT contacts



NOTES: 1. Double pole action is obtained by simultaneous operation of the right and left side single pole switches.  
 2. Rising Level Closes Contacts 5 & 6 and 2 & 3.  
 3. Falling Level Closes Contacts 4 & 5 and 1 & 2.

Figure 6 – Triple Stage with DPDT contacts

NOTE: On high temperature applications above +250° F (+121° C), high temperature wire should be used between control and first junction box located in a cooler area. On non-hazardous applications, flexible conduit may be used between the control and the first junction box.

- Bring supply wires through conduit entry. Route extra wire around enclosing tube under baffle plate, and connect then to the appropriate terminals. Refer to Figures 4–9 for wiring diagrams of Dry Contact Switch Series B, C, D, F, O and Q only. For wiring diagrams for Series HS, J, and K refer to the specific bulletin listed in the chart below:

Switch Series Letter	Description	Bulletin No.
B, C, D, F, O, Q	Dry Contact Switch	42-683
HS	Hermetically Sealed Snap Switch	42-694
J	Bleed Type Pneumatic Switch	42-685
K	Non-Bleed Type Pneumatic Switch	42-686

NOTE: For models with a Series HS switch with high temperature lead wire, the leads are routed out through the conduit opening by the factory. A suitable conduit box should be provided for the connection of the leads to the control wiring.

- Dress wiring to ensure no interference or contact with tilt of switch, or replacement of switch housing cover.

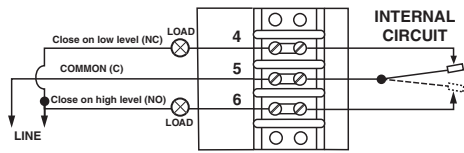
NOTE: Observe all applicable electrical codes and proper wiring procedures.

Prevent moisture seepage into the enclosure by installing approved seal-drain fittings in the conduit run leading into the unit.

**Caution:** In hazardous areas, do not power the unit until the conduit is sealed and the enclosure cover is screwed down securely.

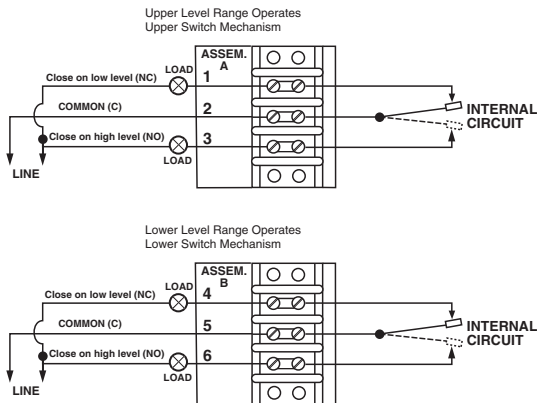
- Test switch action by varying liquid level or manually moving displacers.
- Replace housing cover.
- If control has been furnished with an explosion proof or moisture proof (gasketed) switch housing, it must be sealed at the conduit outlet with a suitable compound or non-hardening sealant to prevent entrance of air.

NOTE: If switch mechanism fails to function properly, check vertical alignment of control housing and consult installation bulletin on switch mechanism furnished.



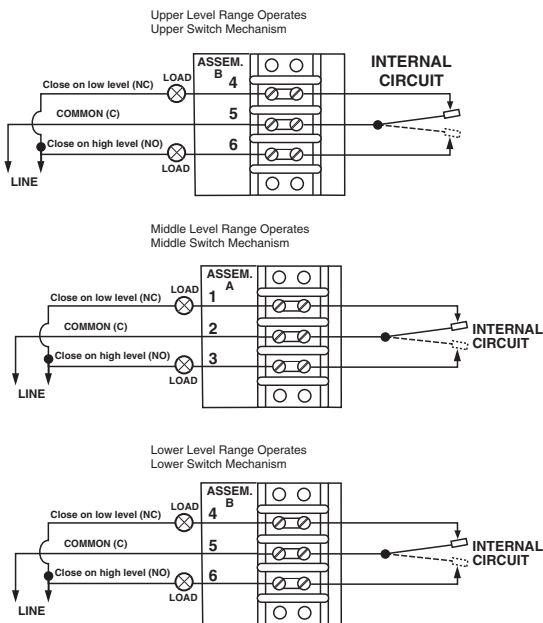
NOTES: 1. Rising level closes contacts 5 & 6.  
2. Falling level closes contacts 4 & 5.

Figure 7 – Single Stage with SPDT contacts



NOTES: 1. Rising level closes contacts 5 & 6 and 2 & 3.  
2. Falling level closes contacts 4 & 5 and 1 & 2.

Figure 8 – Dual Stage with SPDT contacts



NOTES: 1. Rising level closes contacts 5 & 6 and 2 & 3.  
2. Falling level closes contacts 4 & 5 and 1 & 2.

Figure 9 – Triple Stage with SPDT contacts

11. Check cover to base fit to be certain gasketed joint is tight. A positive seal is necessary to prevent infiltration of moisture laden air or corrosive gasses into switch housings.

## 3.0 Preventive Maintenance

Periodic inspections are a necessary means to keep your level control in good working order. This control is a safety device to protect the valuable equipment it serves. A systematic program of “preventive maintenance” must be implemented when the control is placed into service. If the following sections on “What to do” and “What to avoid” are observed, your control will provide reliable protection of your equipment for many years.

### 3.1 Recommended Practice

#### 3.1.1 Keep control clean

Be sure the switch housing cover is always in place on the control. This cover is designed to keep dust and dirt from interfering with switch mechanism operation. It protects against damaging moisture and acts as a safety feature by keeping bare wires and terminals from being exposed. Should the housing cover or any seal become damaged or misplaced, obtain a replacement immediately.

#### 3.1.2 Inspect switch mechanisms, terminals, and connections monthly

1. Dry contact switches should be inspected for excessive wear on actuating lever or misalignment of adjustment screw at point of contact between screw and lever. Such wear can cause false switch actuating levels. See switch mechanism bulletin supplied with control should switch adjustment or replacement be necessary.
2. DO NOT operate your control with defective or mal-adjusted switch mechanisms (refer to bulletin on switch mechanisms furnished for service instructions.)
3. Level controls may sometimes be exposed to excessive heat or moisture. Under such conditions, insulation on electrical wiring may become brittle, eventually breaking or peeling away. The resulting “bare” wires can cause short circuits.

NOTE: Check wiring carefully and replace at the first sign of brittle insulation.



- 
4. Vibration may sometimes cause terminal screws to work loose. Check all terminal connections to be certain that screws are tight.
  5. On units with pneumatic switches, air (or gas) lines subjected to vibration, may eventually crack or become loose at connections causing leakage. Check lines and connections carefully and repair or replace, if necessary.

NOTE: As a matter of good practice, spare switches should be kept on hand at all times.

### **3.2 What to avoid**

1. Never leave switch housing cover off the control longer than necessary to make routine inspections.
2. Never place a jumper wire across terminals to “cut-out” the control. If a “jumper” is necessary for test purposes, be certain it is removed before placing control into service.
3. Never attempt to make adjustments or replace switches without reading instructions carefully. Certain adjustments provided for in level controls should not be attempted in the field. When in doubt, consult the factory or your local representative.
4. Never use lubricants on pivots of switch mechanisms. A sufficient amount of lubricant has been applied at the factory to ensure a lifetime of service. Further oiling is unnecessary and will only tend to attract dust and dirt which can interfere with mechanism operation.
5. Never attempt to readjust magnetic attraction sleeve. It is factory set, and tampering may cause failure of control while in service, even if manual operation activates switch.

---

## 4.0 Reference Information

### 4.1 Troubleshooting

Usually the first indication of improper operation is failure of the controlled equipment to function, i.e., pump will not start (or stop), signal lamps fail to light, etc. When these symptoms occur, whether at time of installation or during routine service thereafter, check the following potential external causes first.

- a. Fuses may be blown.
- b. Reset button(s) may need resetting.
- c. Power switch may be open.
- d. Controlled equipment may be faulty.
- e. Wiring leading to control may be defective.

If a thorough inspection of these possible conditions fails to locate the trouble, proceed next to a check of the control's switch mechanism.

#### 4.1.1 Check switch mechanism

1. Pull disconnect switch or otherwise disconnect power to the control.
2. Remove switch housing cover.
3. Disconnect power wiring from switch assembly.
4. Swing magnet assembly in and out by hand to check carefully for any sign of binding. Assembly should require minimal force to move it through its full swing.
5. If binding exists, magnet may be rubbing enclosing tube. If magnet is rubbing, loosen magnet clamp screw and shift magnet position. Retighten magnet clamp screw.
6. If switch magnet assembly swings freely and mechanism still fails to actuate, check installation of control to be certain it is within the specified three degrees of vertical. (Use spirit level on side of enclosing tube in two places, 90° apart.)
7. Check switch continuity with ohmmeter.

NOTE: As a matter of good practice, spare switches should be kept on hand at all times.

8. If switch mechanism is operating satisfactorily, proceed to check sensing unit.

---

#### 4.1.2 Test control's performance

1. Reconnect power supply and carefully actuate switch mechanism manually, using a non-conductive tool on electrical switch mechanism, to determine whether controlled equipment will operate.

**Caution:** With electrical power on, care should be taken to avoid contact with switch leads and connections at terminal block.

2. If controlled equipment responds to manual actuation test, trouble may be located in level sensing portion of the control (displacers, spring, stem, and magnetic attracting sleeve).

**NOTE:** Check first to be certain liquid is entering tank or vessel. A valve may be closed or pipe line plugged.

3. With liquid in tank or vessel, proceed to check level sensing action by removing switch housing assembly.

**Caution:** Be certain to pull disconnect switch or otherwise assure that electrical circuit(s) through control is deactivated. Close operating medium supply valve on controls equipped with pneumatic switch mechanisms

- a. Disconnect wiring from supply side of switch mechanism(s) and remove electrical conduit or operating medium line connections to switch housing.
  - b. Relieve pressure from vessel and allow unit to cool.
  - c. Remove switch housing assembly by loosening set screws located at the bottom of the housing base.
4. With switch housing assembly removed, inspect attraction sleeve and inside of enclosing tube for excessive corrosion or solids buildup which could restrict movement, preventing sleeve from reaching field of switch magnet.
  5. Inspect displacer stem and spring assembly to assure it is not damaged. If stem or spring is bent or otherwise damaged, movement of the attraction sleeve inside the e-tube will be restricted, preventing proper function of the control.
  6. If trouble is still not located, proceed to remove the entire sensing unit from the tank or vessel by unbolting head flange or unscrewing mounting bushing. Inspect displacer assembly and all internal parts for any signs of damage. Check assembly for binding by supporting head flange or mounting bushing over the edge of a bench and move displacer assembly by hand.

**NOTE:** When in doubt about the condition or performance of a control, contact the factory or consult your local representative.

### 4.1.3 Proof-er

If the Proof-er is not functioning properly, listed below are potential problems and corrective action.





1. Proof-er does not return to the down position after it is activated.

<b>CAUSE</b>	<b>REMEDY</b>
Defective return spring.	Replace Spring.
Buildup between the shaft and housing restricting movement.	Clean Proof-er to remove buildup.
Handle stops are not adjusted properly.	Adjust handle stop screws in or out to allow the handle to move to the proper position.

2. Switch will not trip when Proof-er is activated.

<b>CAUSE</b>	<b>REMEDY</b>
The switch mechanism is defective and not the Proof-er.	Check switch mechanism.
Handle stops are not adjusted properly.	Adjust handle stop screws in or out to allow the handle to move to the proper position.

## 4.2 Agency Approvals

AGENCY	APPROVED MODEL	AREA CLASSIFICATION
<b>FM</b> 	All with an electric switch mechanism and a housing listed as Type 4X/7/9 All with an electric switch mechanism and a housing listed as Type 4X/7/9 Class I, Div 1, Group B	Class I, Div 1, Groups C & D Class II, Div 1, Groups E, F & G Class I, Div 1, Groups B, C & D Class II, Div 1, Groups E, F & G
<b>CSA</b> 	All with a Series HS, F, 8 or 9 electric switch mechanism and a housing listed as CSA Type 4X All with an electric switch mechanism and a housing listed as Type 4X/7/9 All with an electric switch mechanism and a housing listed as Type 4X/7/9 Class I, Div 1, Group B	Class I, Div 2, Groups A, B, C & D Class I, Div 1, Groups C & D Class II, Div 1, Groups E, F & G Class I, Div 1, Groups B, C & D Class II, Div 1, Groups E, F & G
<b>ATEX / IEC Ex</b> <sup>②</sup> 	All with an electric switch mechanism and an ATEX housing <sup>①</sup>	ATEX II 2 G Ex d IIC T6 94/9/EC IEC Ex Ex d IIC T6 IP66
<b>CE</b> 	All models	Installation Category II Pollution Degree 2 Low Voltage Directives 2006/95/EC per Harmonized Standard EN 61010-1/1993 & Amendment No. 1

① Controls with two or more HS or H1 switches are not ATEX approved.

② IEC Installation Instructions:

The cable entry and closing devices shall be Ex d certified suitable for the conditions of use and correctly installed.  
 For ambient temperatures above +55 °C or for process temperatures above +150 °C, suitable heat resistant cables shall be used.  
 Heat extensions (between process connection and housing) shall never be insulated.

**Special conditions for safe use:**

When the equipment is installed in process temperatures higher than +85 °C the temperature classification must be reduced according to the following table as per IEC60079-0.

Maximum Process Temperature	Temperature Classification
< 85 °C	T6
< 100 °C	T5
< 135 °C	T4
< 200 °C	T3
< 300 °C	T2
< 450 °C	T1

These units are in conformity with IECEx KEM 05.0020X  
 Classification Ex d IIC T6  
 T<sub>ambient</sub> -40 °C to +70 °C

## 4.3 Specifications

### 4.3.1 Basic Electrical Ratings

Displacer	Switch Series and Non-Inductive Ampere Rating						
	B	C	D	F	HS	O	Q
120 VAC	15.00	15.00	10.00	2.50	5.00	15.00	15.00
240 VAC	15.00	15.00	—	—	5.00	15.00	15.00
24 VDC	6.00	6.00	10.00	4.00	5.00	6.00	6.00
120 VDC	0.50	1.00	10.00	0.30	0.50	1.00	0.50
240 VDC	0.25	0.50	3.00	—	0.25	0.50	0.25

### 4.3.2 Pressure/Temperature Ratings

Threaded Models ③④	800 psig @ +100 °F (55 bar @ +38 °C) 250 psig @ +400 °F (17 bar @ +204 °C)
Flanged Models ④	Limited to the pressure rating of the selected flange or displacer. Flanges conform to ASME B16.5.
Low Pressure Proof-er Models	25 psig @ +200 °F (1.7 bar @ +93 °C)
Medium Pressure Proof-er Models	125 psig @ +300 °F (8.6 bar @ +149 °C)

③ Models with stainless steel displacers are rated 720 psig @ +100 °F (50 bar @ +38 °C)

④ Cryogenic construction available upon request. Consult factory with application details.

## 4.3 Specifications

### 4.3.3 Model A10 Dimensional Data and Actuating Levels

Inches (mm)

#### Model A10

Displacer Type	Outline Dimensions			
	Threaded Mounting		Flanged Mounting	
	A	B	A	B
Porcelain	5.00 (127)	242.00 (6146)	7.00 (177)	244.00 (6197)
Stainless Steel or Karbate®	4.75 (120)	242.00 (6146)	6.75 (171)	244.00 (6197)

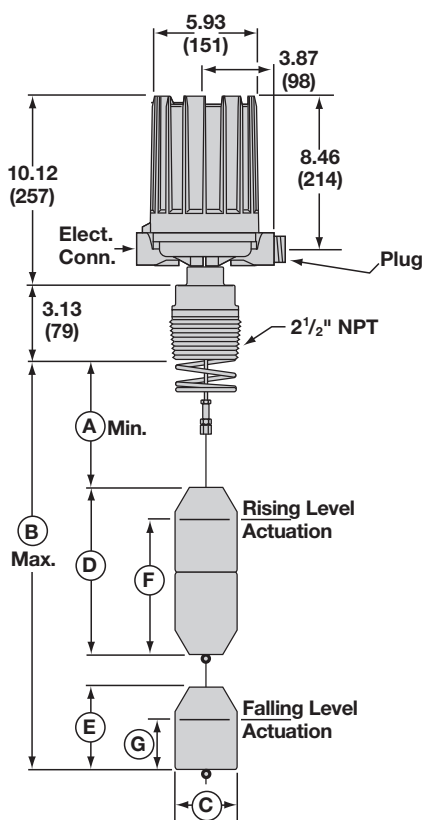
Displacer Type	C	D	E
Porcelain	2.56 (65)	7.25 (184)	3.62 (91)
Stainless Steel or Karbate	2.50 (63)	9.00 (228)	4.50 (114)

Electrical Connections
NEMA 4X/7/9, Group B: 1" NPT
NEMA 1 Pneumatic: ¼" NPT

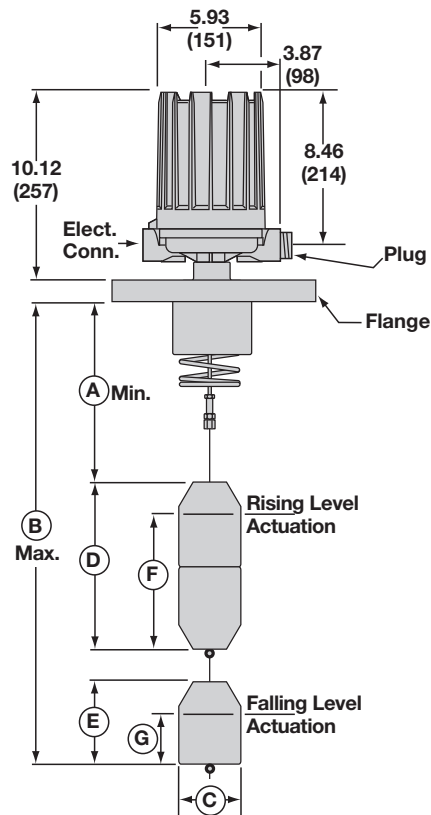
#### A10 Standard actuating levels and liquid specific gravity

Displacer Type	Liquid Temp. °F	0.60		0.70		0.80		0.90		1.00	
		F	G	F	G	F	G	F	G	F	G
Porcelain	+100	5.30 (134)	1.50 (38)	4.10 (104)	1.20 (30)	3.20 (81)	1.10 (27)	2.50 (63)	1.00 (25)	2.00 (50)	0.90 (22)
	+200	—	—	4.80 (121)	2.00 (50)	3.80 (96)	1.80 (45)	3.00 (76)	1.60 (40)	2.50 (63)	1.50 (38)
	+300	—	—	—	—	4.30 (109)	2.40 (60)	3.40 (86)	2.10 (53)	2.90 (73)	1.90 (48)
	+400	—	—	—	—	—	—	3.40 (86)	2.60 (66)	2.90 (73)	2.40 (60)
Stainless Steel or Karbate	+100	7.00 (177)	2.40 (60)	5.30 (134)	2.00 (50)	4.10 (104)	1.80 (45)	3.10 (78)	1.60 (40)	2.40 (60)	1.40 (35)
	+200	—	—	5.90 (149)	2.80 (71)	4.70 (119)	2.50 (63)	3.60 (91)	2.20 (55)	2.80 (71)	2.00 (50)
	+300	—	—	—	—	5.10 (129)	3.10 (78)	4.00 (101)	2.70 (68)	3.20 (81)	2.40 (60)
Stainless Steel	+400	—	—	—	—	—	—	4.40 (111)	3.20 (81)	3.60 (91)	2.90 (73)
	+500	—	—	—	—	—	—	—	—	3.90 (99)	3.30 (83)

Note: All levels  $\pm 0.25"$  (6).



**Model A10**  
with Threaded Mounting



**Model A10**  
with Flanged Mounting

## 4.3 Specifications

### 4.3.4 Model A15 Dimensional Data and Actuating Levels\*

Inches (mm)

#### Model A15

Displacer Type	Outline Dimensions			
	Threaded Mounting		Flanged Mounting	
	A	B	A	B
Porcelain	5.62 (142)	242.00 (6146)	7.62 (193)	244.00 (6197)
Stainless Steel or Karbate	5.62 (142)	242.00 (6146)	7.62 (193)	244.00 (6197)

Displacer Type	C	D
Porcelain	2.56 (65)	7.25 (184)
Stainless Steel or Karbate	2.50 (63)	9.00 (228)

#### Electrical Connections

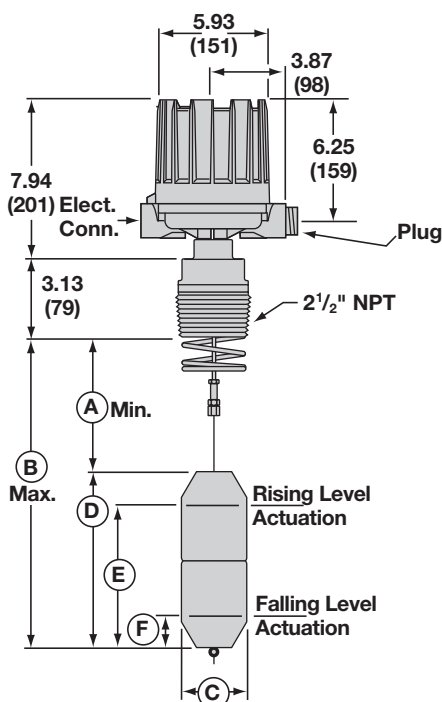
NEMA 4X/7/9, Group B: 1" NPT  
NEMA 1 Pneumatic: 1/4" NPT

#### A15 Standard actuating levels and liquid specific gravity

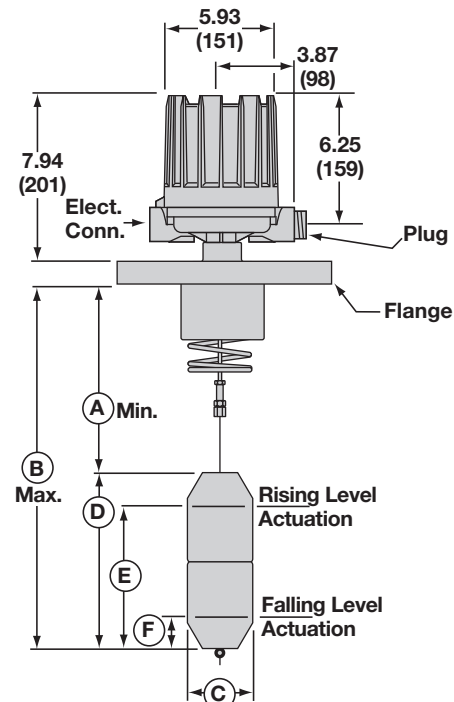
Displacer Type	Liquid Temp. °F	0.50		0.60		0.70		0.80		0.90		1.00	
		E	F	E	F	E	F	E	F	E	F	E	F
Porcelain	+100	—	—	5.10 (129)	2.10 (53)	4.50 (114)	1.70 (43)	3.90 (99)	1.70 (43)	3.50 (88)	1.50 (38)	3.20 (81)	1.40 (35)
	+200	—	—	5.60 (142)	2.60 (66)	4.90 (124)	2.10 (53)	4.30 (109)	2.10 (53)	3.80 (96)	1.80 (45)	3.50 (88)	1.70 (43)
	+300	—	—	—	—	5.20 (132)	2.40 (60)	4.50 (114)	2.30 (58)	4.10 (104)	2.10 (53)	3.70 (93)	1.90 (48)
	+400	—	—	—	—	5.60 (142)	2.80 (71)	4.80 (121)	2.60 (66)	4.30 (109)	2.30 (58)	3.90 (99)	2.10 (53)
	+500	—	—	—	—	—	—	5.10 (129)	2.90 (73)	4.60 (116)	2.60 (66)	4.20 (106)	2.40 (60)
Stainless Steel or Karbate	+100	5.40 (137)	2.00 (50)	4.50 (114)	1.60 (40)	3.90 (99)	1.40 (35)	3.40 (86)	1.20 (30)	3.00 (76)	1.10 (27)	2.70 (68)	1.00 (25)
	+200	6.00 (152)	2.60 (66)	5.00 (127)	2.10 (53)	4.30 (109)	1.80 (45)	3.70 (93)	1.60 (40)	3.30 (83)	1.40 (35)	3.00 (76)	1.30 (33)
	+300	6.40 (162)	3.00 (76)	5.30 (134)	2.40 (60)	4.60 (116)	2.10 (53)	4.00 (101)	1.80 (45)	3.60 (91)	1.70 (43)	3.20 (81)	1.50 (38)
Stainless Steel	+400	6.90 (175)	3.50 (88)	5.70 (144)	2.80 (71)	4.90 (124)	2.40 (60)	4.30 (109)	2.10 (53)	3.80 (96)	1.90 (48)	3.40 (86)	1.70 (43)
	+500	—	—	6.10 (154)	3.20 (81)	5.20 (132)	2.80 (71)	4.60 (116)	2.40 (60)	4.10 (104)	2.20 (55)	3.70 (93)	2.00 (50)

Note: All levels  $\pm 0.25"$  (6).

\*See pages 31 and 32 for Proof-er and/or Floating roof top switch dimensions.



**Model A15  
with Threaded Mounting**



**Model A15  
with Flanged Mounting**

## 4.3 Specifications

### 4.3.5 Model B10 Dimensional Data

Inches (mm)

#### Model B10

Displacer Type	Outline Dimensions			
	Threaded Mounting		Flanged Mounting	
	A	B	A	B
Porcelain	4.88 (123)	242.00 (6146)	6.88 (174)	244.00 (6197)
Stainless Steel or Karbate	4.75 (120)	242.00 (6146)	6.75 (171)	244.00 (6197)

#### Model B10 with displacer arrangements 1 and 2

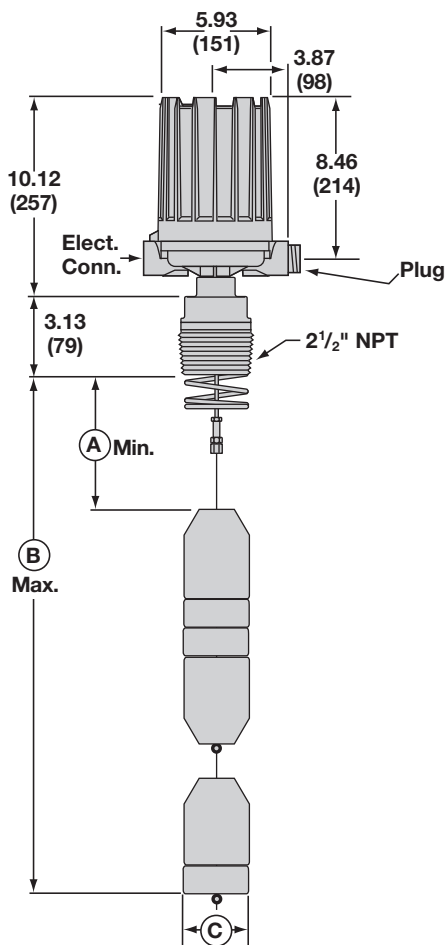
Displacer Type	C	D	E
Porcelain	2.56 (65)	10.04 (255)	5.02 (127)
Stainless Steel or Karbate	2.50 (63)	12.00 (304)	6.00 (152)

#### Model B10 with displacer arrangements 3, 4, and 5

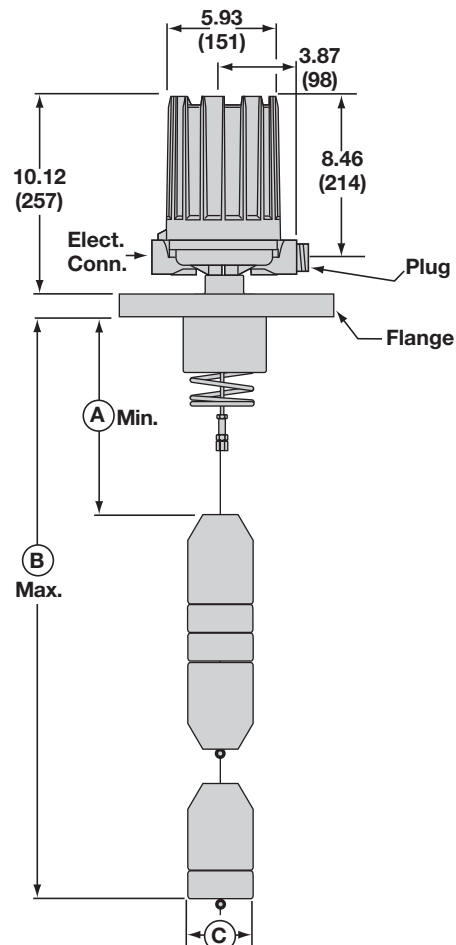
Displacer Type	C	D	E	F
Porcelain	2.56 (65)	5.02 (127)	5.02 (127)	5.02 (127)
Stainless Steel or Karbate	2.50 (63)	6.00 (152)	6.00 (152)	6.00 (152)

#### Electrical Connections

NEMA 4X/7/9  
Group B: 1" NPT



Model B10  
with Threaded Mounting



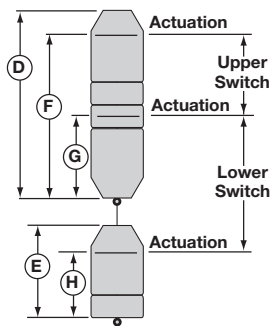
Model B10  
with Flanged Mounting



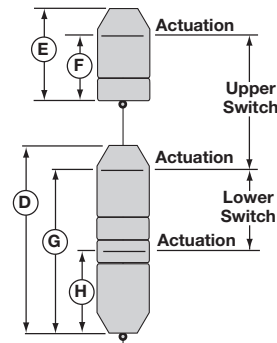
## 4.3 Specifications

### 4.3.6 Model B10 Actuating Levels

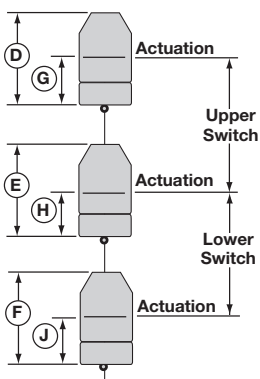
Inches (mm)



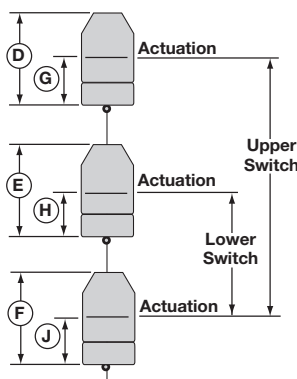
**Model B10**  
**Displacer Arrangement 1**



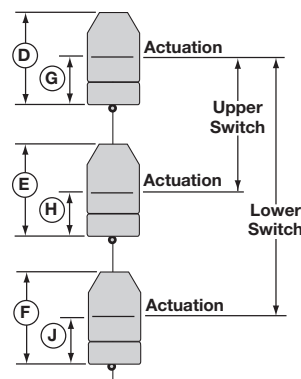
**Model B10**  
**Displacer Arrangement 2**



**Model B10**  
**Displacer Arrangement 3**



**Model B10**  
**Displacer Arrangement 4**



**Model B10**  
**Displacer Arrangement 5**

#### B10 Standard actuating levels and liquid specific gravity with displacer arrangement 1

Displacer Type	Liquid Temp. ° F	Level	0.60 – 0.64	0.65 – 0.71	0.72 – 0.73	0.74 – 0.82	0.83 – 0.92	0.93 – 1.00	1.01 – 1.07
Porcelain	+100	F	7.79 – 7.04 (197 – 178)	7.66 – 6.65 (194 – 168)	7.22 – 7.06 (133 – 179)	6.91 – 5.81 (175 – 147)	6.73 – 5.65 (180 – 143)	5.55 – 4.86 (140 – 123)	4.97 – 4.53 (126 – 115)
		G	2.62 – 2.19 (56 – 55)	2.88 – 2.28 (73 – 57)	2.91 – 2.81 (73 – 71)	2.71 – 2.03 (68 – 51)	2.99 – 2.28 (75 – 57)	2.21 – 1.76 (56 – 44)	1.90 – 1.63 (48 – 41)
		H	2.01 – 1.89 (51 – 48)	1.86 – 1.70 (47 – 43)	1.68 – 1.65 (42 – 41)	1.63 – 1.47 (41 – 37)	1.45 – 1.31 (36 – 33)	1.30 – 1.21 (33 – 30)	1.02 – 0.97 (25 – 24)
	+200	F	7.91 (200)	7.72 – 6.71 (196 – 170)	6.56 – 6.41 (166 – 162)	6.73 – 5.66 (170 – 143)	6.37 – 5.33 (161 – 135)	6.15 – 5.42 (156 – 137)	5.02 – 4.57 (127 – 116)
		G	3.06 (77)	2.95 – 2.34 (74 – 59)	2.25 – 2.16 (57 – 54)	2.54 – 1.87 (64 – 47)	2.63 – 1.95 (66 – 49)	2.81 – 2.32 (71 – 58)	1.94 – 1.67 (49 – 42)
		H	2.76 (70)	2.72 – 2.49 (69 – 63)	2.45 – 2.42 (62 – 61)	2.39 – 2.15 (60 – 54)	2.13 – 1.92 (54 – 48)	1.90 – 1.77 (48 – 44)	1.58 – 1.49 (40 – 37)
	+300	F	—	—	—	7.48 – 6.34 (189 – 161)	7.04 – 5.93 (178 – 150)	6.75 – 5.98 (171 – 151)	5.57 – 5.10 (141 – 129)
		G	—	—	—	3.29 – 2.55 (83 – 64)	3.30 – 2.56 (83 – 65)	3.41 – 2.87 (86 – 72)	2.50 – 2.19 (63 – 55)
		H	—	—	—	3.14 – 2.83 (79 – 71)	2.80 – 2.53 (71 – 64)	2.50 – 2.32 (63 – 58)	2.13 – 2.01 (54 – 51)
	+400	F	—	—	—	—	—	—	6.12 – 5.62 (155 – 142)
		G	—	—	—	—	—	—	3.05 – 2.72 (77 – 69)
		H	—	—	—	—	—	—	2.68 – 2.53 (68 – 64)

Note: All levels  $\pm 0.25^{\circ}$  (6).

## 4.3 Specifications

### 4.3.6 Model B10 Actuating Levels (cont.)

Inches (mm)

**B10 Standard actuating levels and liquid specific gravity with displacer arrangement 1**

Displacer Type	Liquid Temp. ° F	Level	1.08 – 1.12	1.13 – 1.17	1.18 – 1.27	1.28 – 1.30	1.31 – 1.39	1.40 – 1.50
Porcelain	+100	F	4.47 – 4.20 (113 – 106)	4.90 – 4.64 (124 – 117)	4.57 – 4.05 (116 – 102)	3.99 – 3.89 (101 – 98)	4.23 – 3.82 (107 – 97)	3.77 – 3.33 (95 – 84)
		G	1.59 – 1.43 (40 – 36)	2.16 – 1.99 (54 – 50)	1.94 – 1.60 (49 – 40)	1.57 – 1.50 (39 – 38)	1.86 – 1.59 (47 – 40)	1.56 – 1.26 (39 – 32)
		H	0.96 – 0.92 (24 – 23)	0.92 – 0.88 (23 – 22)	0.88 – 0.81 (22 – 20)	0.81 – 0.80 (20 – 20)	0.79 – 0.74 (20 – 18)	0.74 – 0.69 (18 – 17)
	+200	F	4.66 – 4.39 (118 – 111)	4.33 – 4.08 (109 – 103)	4.32 – 3.81 (109 – 96)	4.29 – 4.18 (108 – 106)	4.13 – 3.73 (104 – 94)	3.93 – 3.47 (99 – 88)
		G	1.79 – 1.62 (45 – 41)	1.58 – 1.43 (40 – 36)	1.69 – 1.36 (42 – 34)	1.87 – 1.80 (47 – 45)	1.76 – 1.49 (44 – 37)	1.71 – 1.40 (43 – 35)
		H	1.48 – 1.42 (37 – 36)	1.41 – 1.36 (35 – 34)	1.35 – 1.25 (34 – 31)	1.24 – 1.23 (31 – 31)	1.22 – 1.15 (30 – 29)	1.14 – 1.06 (28 – 26)
	+300	F	5.18 – 4.89 (131 – 124)	4.82 – 4.56 (122 – 115)	4.79 – 4.25 (121 – 107)	4.73 – 4.61 (120 – 117)	4.56 – 4.13 (115 – 104)	4.32 – 3.84 (109 – 97)
		G	2.31 – 2.12 (58 – 53)	2.08 – 1.91 (52 – 48)	2.16 – 1.80 (54 – 45)	2.31 – 2.23 (58 – 56)	2.19 – 1.90 (55 – 48)	2.11 – 1.78 (53 – 45)
		H	1.99 – 1.92 (50 – 48)	1.90 – 1.84 (48 – 46)	1.82 – 1.69 (45 – 42)	1.68 – 1.66 (42 – 42)	1.64 – 1.55 (41 – 39)	1.54 – 1.43 (39 – 36)
	+400	F	5.70 – 5.39 (144 – 136)	5.32 – 5.04 (135 – 128)	5.26 – 4.69 (133 – 119)	5.17 – 5.04 (131 – 128)	4.98 – 4.53 (126 – 115)	4.72 – 4.22 (119 – 107)
		G	2.82 – 2.62 (71 – 66)	2.57 – 2.39 (65 – 60)	2.63 – 2.24 (66 – 56)	2.74 – 2.66 (69 – 67)	2.61 – 2.30 (66 – 58)	2.51 – 2.15 (63 – 54)
		H	2.51 – 2.42 (63 – 61)	2.40 – 2.32 (60 – 58)	2.30 – 2.13 (58 – 54)	2.12 – 2.08 (53 – 52)	2.07 – 1.95 (52 – 49)	1.94 – 1.81 (49 – 45)
	+500	F	6.22 – 5.89 (157 – 149)	5.81 – 5.52 (147 – 140)	5.74 – 5.13 (145 – 130)	5.60 – 5.47 (142 – 138)	5.41 – 4.93 (137 – 125)	5.12 – 4.59 (130 – 116)
		G	3.34 – 3.12 (84 – 79)	3.07 – 2.86 (77 – 72)	3.11 – 2.68 (78 – 68)	3.18 – 3.09 (80 – 78)	3.04 – 2.70 (77 – 68)	2.91 – 2.52 (73 – 64)
		H	3.03 – 2.92 (76 – 74)	2.89 – 2.79 (73 – 70)	2.77 – 2.57 (70 – 65)	2.55 – 2.51 (64 – 63)	2.50 – 2.35 (63 – 59)	2.33 – 2.18 (59 – 55)

Note: All levels  $\pm 0.25"$  (6).

Displacer Type	Liquid Temp. ° F	Level	0.50 – 0.58	0.59 – 0.71	0.72 – 0.79	0.80 – 0.85	0.86 – 1.00	1.01 – 1.03
Stainless Steel and Karbate	+100	F	9.91 – 7.72 (251 – 196)	9.19 – 6.62 (233 – 168)	8.44 – 7.16 (214 – 181)	7.66 – 6.86 (194 – 174)	6.71 – 4.93 (170 – 125)	4.82 – 4.61 (122 – 117)
		G	3.46 – 2.16 (86 – 54)	3.72 – 2.08 (94 – 52)	3.96 – 3.07 (100 – 77)	3.63 – 3.07 (92 – 77)	2.96 – 1.71 (75 – 43)	1.63 – 1.48 (41 – 37)
		H	2.51 – 2.16 (63 – 54)	2.13 – 1.77 (54 – 44)	1.74 – 1.59 (44 – 40)	1.57 – 1.48 (39 – 37)	1.46 – 1.25 (37 – 31)	1.24 – 1.22 (31 – 30)
	+200	F	10.22 – 7.98 (259 – 202)	7.74 – 7.44 (196 – 188)	7.50 – 6.30 (190 – 160)	6.15 – 5.44 (156 – 138)	6.97 – 5.15 (177 – 130)	—
		G	3.76 – 2.42 (95 – 61)	2.27 – 1.89 (57 – 48)	3.02 – 2.22 (76 – 56)	2.12 – 1.64 (53 – 41)	3.22 – 1.93 (81 – 49)	—
		H	3.67 – 3.16 (93 – 80)	3.11 – 2.58 (78 – 65)	2.55 – 2.32 (64 – 58)	2.29 – 2.16 (58 – 54)	2.13 – 1.84 (54 – 46)	—
	+300	F	—	9.68 – 7.25 (245 – 184)	8.31 – 7.04 (211 – 178)	6.88 – 6.12 (174 – 155)	7.65 – 5.73 (194 – 145)	—
		G	—	4.30 – 2.70 (109 – 68)	3.83 – 2.96 (97 – 75)	2.84 – 2.32 (72 – 58)	3.89 – 2.51 (98 – 63)	—
		H	—	4.03 – 3.40 (102 – 86)	3.36 – 3.06 (85 – 77)	3.02 – 2.84 (76 – 72)	2.81 – 2.42 (71 – 61)	—

Note: All levels  $\pm 0.25"$  (6).

continued on next page

## 4.3 Specifications

### 4.3.6 Model B10 Actuating Levels (cont.)

Inches (mm)

#### B10 Standard actuating levels and liquid specific gravity with displacer arrangement 1 (cont.)

Displacer Type	Liquid Temp. ° F	Level	0.50 – 0.58	0.59 – 0.71	0.72 – 0.79	0.80 – 0.85	0.86 – 1.00	1.01 – 1.03
Stainless Steel	+400	F	—	—	9.11 – 7.77 (231 – 197)	7.60 – 6.80 (193 – 172)	8.32 – 6.32 (211 – 160)	—
		G	—	—	4.63 – 3.69 (117 – 93)	3.57 – 3.01 (90 – 76)	4.57 – 3.09 (116 – 78)	—
		H	—	—	4.16 – 3.79 (105 – 96)	3.75 – 3.53 (95 – 89)	3.48 – 3.00 (88 – 76)	—
	+500	F	—	—	—	—	9.00 – 6.90 (228 – 175)	—
		G	—	—	—	—	5.24 – 3.67 (133 – 93)	—
		H	—	—	—	—	4.16 – 3.58 (105 – 90)	—

Note: All levels ±0.25" (6).

#### B10 Standard actuating levels and liquid specific gravity with displacer arrangement 2

Displacer Type	Liquid Temp. ° F	Level	0.60 – 0.64	0.65 – 0.71	0.72 – 0.73	0.74 – 0.82	0.83 – 0.92	0.93 – 1.00	1.01 – 1.07
Porcelain	+100	F	2.77 – 2.01 (70 – 51)	2.63 – 1.62 (66 – 41)	2.67 – 2.51 (67 – 63)	2.58 – 1.42 (65 – 36)	3.16 – 1.94 (80 – 49)	1.82 – 1.04 (45 – 26)	1.69 – 1.23 (42 – 31)
		G	7.27 – 6.84 (184 – 173)	7.54 – 6.93 (191 – 176)	7.56 – 7.46 (192 – 189)	7.36 – 6.68 (186 – 169)	7.64 – 6.93 (194 – 176)	6.86 – 6.41 (174 – 162)	5.15 – 4.89 (130 – 124)
		H	2.67 – 2.53 (67 – 64)	3.29 – 3.05 (83 – 77)	3.73 – 3.68 (94 – 93)	3.64 – 3.32 (92 – 84)	4.32 – 3.93 (109 – 99)	3.90 – 3.65 (99 – 92)	2.42 – 2.31 (61 – 58)
	+200	F	3.15 (80)	2.96 – 1.93 (75 – 49)	1.77 – 1.62 (44 – 41)	2.64 – 1.47 (67 – 37)	2.79 – 1.61 (70 – 40)	2.79 – 1.94 (70 – 49)	1.56 – 1.11 (39 – 28)
		G	7.71 (195)	7.60 – 6.99 (193 – 177)	6.90 – 6.81 (175 – 172)	7.19 – 6.52 (182 – 165)	7.28 – 6.60 (184 – 167)	7.46 – 6.97 (189 – 177)	5.19 – 4.92 (131 – 124)
		H	3.40 (86)	3.36 – 3.10 (85 – 78)	3.07 – 3.03 (77 – 76)	3.46 – 3.16 (87 – 80)	3.96 – 3.61 (100 – 91)	4.50 – 4.21 (114 – 106)	2.46 – 2.35 (62 – 59)
	+300	F	—	—	—	3.39 – 2.15 (86 – 54)	3.47 – 2.22 (88 – 56)	3.39 – 2.50 (86 – 63)	2.11 – 1.63 (53 – 41)
		G	—	—	—	7.94 – 7.20 (201 – 182)	7.95 – 7.21 (201 – 183)	8.06 – 7.53 (204 – 191)	5.75 – 5.45 (146 – 138)
		H	—	—	—	4.21 – 3.84 (106 – 97)	4.63 – 4.21 (117 – 106)	5.10 – 4.77 (129 – 121)	3.02 – 2.87 (76 – 72)
	+400	F	—	—	—	—	—	—	2.67 – 2.15 (67 – 54)
		G	—	—	—	—	—	—	6.30 – 5.97 (160 – 151)
		H	—	—	—	—	—	—	3.57 – 3.39 (90 – 86)

Note: All levels ±0.25" (6).

## 4.3 Specifications

### 4.3.6 Model B10 Actuating Levels (cont.)

Inches (mm)

**B10 Standard actuating levels and liquid specific gravity with displacer arrangement 2 (cont.)**

Displacer Type	Liquid Temp. ° F	Level	1.08 – 1.12	1.13 – 1.17	1.18 – 1.27	1.28 – 1.30	1.31 – 1.39	1.40 – 1.50
Porcelain	+100	F	1.16 – 0.89 (29 – 22)	2.04 – 1.75 (51 – 44)	1.68 – 1.10 (42 – 27)	1.04 – 0.92 (26 – 23)	2.05 – 1.56 (52 – 39)	1.50 – 0.97 (38 – 24)
		G	4.84 – 4.68 (122 – 118)	5.41 – 5.24 (137 – 133)	5.20 – 4.85 (132 – 123)	4.82 – 4.75 (122 – 120)	5.11 – 4.84 (129 – 122)	4.81 – 4.51 (122 – 114)
		H	2.29 – 2.22 (58 – 56)	2.97 – 2.88 (75 – 73)	2.86 – 2.68 (72 – 68)	2.66 – 2.63 (67 – 66)	3.01 – 2.85 (76 – 72)	2.84 – 2.67 (72 – 67)
	+200	F	1.68 – 1.38 (42 – 35)	1.31 – 1.05 (33 – 26)	1.71 – 1.13 (43 – 28)	1.75 – 1.62 (44 – 41)	1.56 – 1.09 (39 – 27)	1.53 – 1.00 (38 – 25)
		G	5.04 – 4.88 (128 – 123)	4.84 – 4.68 (122 – 118)	4.94 – 4.62 (125 – 117)	5.12 – 5.05 (130 – 128)	5.01 – 4.75 (127 – 120)	4.96 – 4.65 (125 – 118)
		H	2.49 – 2.41 (63 – 61)	2.39 – 2.33 (60 – 59)	2.60 – 2.44 (66 – 61)	2.97 – 2.93 (73 – 70)	2.91 – 2.76 (73 – 70)	2.99 – 2.82 (75 – 77)
	+300	F	2.19 – 1.88 (55 – 47)	1.81 – 1.52 (45 – 38)	2.19 – 1.57 (55 – 39)	2.18 – 2.05 (50 – 37)	1.98 – 1.49 (50 – 37)	1.93 – 1.37 (49 – 34)
		G	5.56 – 5.37 (141 – 136)	5.33 – 5.16 (135 – 131)	5.41 – 5.06 (137 – 128)	5.56 – 5.48 (138 – 130)	5.44 – 5.15 (138 – 130)	5.36 – 5.03 (136 – 127)
		H	3.01 – 2.91 (76 – 73)	2.89 – 2.80 (73 – 71)	3.07 – 2.88 (77 – 73)	3.40 – 3.36 (84 – 80)	3.33 – 3.16 (84 – 80)	3.39 – 3.19 (86 – 81)
	+400	F	2.71 – 2.38 (68 – 60)	2.30 – 2.00 (58 – 50)	2.66 – 2.01 (67 – 51)	2.62 – 2.48 (61 – 48)	2.41 – 1.90 (61 – 48)	2.33 – 1.74 (59 – 44)
		G	6.08 – 5.87 (154 – 149)	5.82 – 5.64 (147 – 143)	5.89 – 5.49 (149 – 139)	5.99 – 5.91 (152 – 150)	5.87 – 5.55 (149 – 140)	5.76 – 5.40 (146 – 137)
		H	3.52 – 3.41 (89 – 86)	3.38 – 3.28 (85 – 83)	3.55 – 3.32 (90 – 84)	3.84 – 3.79 (97 – 96)	3.76 – 3.56 (95 – 90)	3.79 – 3.56 (96 – 90)
	+500	F	3.23 – 2.88 (82 – 73)	2.80 – 2.48 (71 – 62)	3.13 – 2.45 (79 – 62)	3.05 – 2.91 (77 – 73)	2.84 – 2.30 (72 – 58)	2.73 – 2.11 (69 – 53)
		G	6.59 – 6.37 (167 – 161)	6.32 – 6.12 (160 – 155)	6.36 – 5.93 (161 – 150)	6.43 – 6.34 (163 – 161)	6.29 – 5.95 (159 – 151)	6.16 – 5.77 (156 – 146)
		H	4.04 – 3.91 (102 – 99)	3.88 – 3.76 (98 – 95)	4.02 – 3.76 (102 – 95)	4.28 – 4.21 (108 – 106)	4.19 – 3.97 (106 – 100)	4.19 – 3.93 (106 – 99)

Note: All levels  $\pm 0.25"$  (6).

## 4.3 Specifications

### 4.3.6 Model B10 Actuating Levels (cont.)

Inches (mm)

#### B10 Standard actuating levels and liquid specific gravity with displacer arrangement 2

Displacer Type	Liquid Temp. ° F	Level	0.50 – 0.58	0.59 – 0.71	0.72 – 0.79	0.80 – 0.85	0.86 – 1.00	1.01 – 1.03
Stainless Steel and Karbate	+100	F	3.77 – 1.60 (95 – 40)	4.10 – 1.38 (104 – 35)	4.43 – 2.97 (112 – 75)	4.58 – 3.60 (24 – 91)	3.42 – 1.26 (86 – 31)	1.13 – 0.88 (28 – 22)
		G	9.46 – 8.16 (240 – 207)	9.72 – 8.08 (246 – 205)	9.96 – 9.07 (252 – 230)	9.63 – 9.07 (244 – 230)	8.96 – 7.71 (227 – 195)	7.63 – 7.48 (193 – 189)
		H	3.73 – 3.21 (94 – 81)	4.86 – 4.04 (123 – 102)	5.97 – 5.44 (151 – 138)	6.05 – 5.69 (153 – 144)	5.63 – 4.84 (143 – 122)	4.79 – 4.70 (121 – 119)
	+200	F	4.22 – 1.98 (107 – 50)	1.74 – 1.44 (44 – 36)	3.74 – 2.35 (94 – 59)	2.17 – 1.33 (55 – 33)	3.89 – 1.66 (98 – 42)	—
		G	9.76 – 8.42 (247 – 213)	8.27 – 6.88 (210 – 174)	9.02 – 8.22 (229 – 208)	8.12 – 7.64 (206 – 194)	9.22 – 7.93 (234 – 201)	—
		H	4.03 – 3.47 (102 – 88)	3.41 – 2.84 (86 – 62)	5.04 – 4.59 (128 – 116)	4.53 – 4.27 (115 – 108)	5.88 – 5.06 (149 – 128)	—
	+300	F	—	4.87 – 2.26 (123 – 57)	4.55 – 3.08 (115 – 78)	2.89 – 2.02 (73 – 51)	4.56 – 2.24 (115 – 56)	—
		G	—	10.30 – 8.70 (261 – 220)	9.83 – 8.96 (249 – 227)	8.84 – 8.32 (224 – 211)	9.89 – 8.51 (251 – 216)	—
		H	—	5.52 – 4.66 (140 – 118)	5.84 – 5.33 (148 – 135)	5.26 – 4.95 (133 – 125)	6.56 – 5.64 (166 – 131)	—
Stainless Steel	+400	F	—	—	5.35 – 3.82 (135 – 97)	3.62 – 2.70 (91 – 68)	5.24 – 2.82 (133 – 71)	—
		G	—	—	10.63 – 9.69 (270 – 246)	9.57 – 9.01 (243 – 228)	10.57 – 9.09 (183 – 157)	—
		H	—	—	6.65 – 6.06 (168 – 153)	5.99 – 5.63 (152 – 143)	7.24 – 6.22 (183 – 157)	—
	+500	F	—	—	—	—	5.91 – 3.41 (150 – 86)	—
		G	—	—	—	—	11.24 – 9.67 (285 – 245)	—
		H	—	—	—	—	7.91 – 6.80 (200 – 172)	—

Note: All levels ±0.25" (6).

#### B10 Standard actuating levels and liquid specific gravity with displacer arrangements 3, 4, and 5

Displacer Type	Liquid Temp. ° F	Level	0.60 – 0.64	0.65 – 0.71	0.72 – 0.73	0.74 – 0.82	0.83 – 0.92	0.93 – 1.00	1.01 – 1.07
Porcelain	+100	G	2.77 – 2.01 (70 – 51)	2.63 – 1.62 (66 – 41)	2.67 – 2.51 (67 – 63)	2.58 – 1.42 (65 – 36)	3.16 – 1.94 (80 – 49)	1.82 – 1.04 (45 – 26)	1.69 – 1.23 (42 – 31)
		H	2.24 – 1.81 (56 – 45)	2.51 – 1.90 (63 – 48)	2.53 – 2.43 (64 – 61)	2.34 – 1.66 (59 – 42)	2.62 – 1.91 (66 – 48)	1.84 – 1.38 (46 – 35)	1.53 – 1.26 (38 – 32)
		J	2.01 – 1.89 (51 – 48)	1.86 – 1.70 (47 – 43)	1.68 – 1.65 (42 – 41)	1.63 – 1.47 (41 – 37)	1.45 – 1.31 (36 – 33)	1.30 – 1.21 (33 – 30)	1.02 – .097 (25 – 24)
	+200	G	3.15 (80)	2.96 – 1.93 (75 – 49)	1.77 – 1.62 (44 – 41)	2.64 – 1.47 (67 – 37)	2.79 – 1.61 (70 – 40)	2.79 – 1.94 (70 – 49)	1.56 – 1.11 (39 – 28)
		H	2.69 (68)	2.57 – 1.96 (965 – 49)	1.87 – 1.78 (47 – 45)	2.16 – 1.50 (54 – 38)	2.25 – 1.58 (57 – 40)	2.44 – 1.94 (61 – 49)	1.40 – 1.14 (35 – 28)
		J	2.76 (70)	2.72 – 2.49 (69 – 63)	2.45 – 2.42 (62 – 61)	2.39 – 2.15 (60 – 54)	2.13 – 1.92 (54 – 48)	1.90 – 1.77 (48 – 44)	1.58 – 1.49 (40 – 37)
	+300	G	—	—	—	3.39 – 2.15 (86 – 54)	3.47 – 2.22 (88 – 56)	3.39 – 2.50 (86 – 63)	2.11 – 1.63 (53 – 41)
		H	—	—	—	2.92 – 2.18 (74 – 55)	2.93 – 2.18 (74 – 55)	3.04 – 2.50 (77 – 63)	1.95 – 1.66 (49 – 42)
		J	—	—	—	3.14 – 2.83 (79 – 71)	2.80 – 2.53 (71 – 64)	2.50 – 2.32 (63 – 58)	2.13 – 2.01 (54 – 51)
	+400	G	—	—	—	—	—	—	2.67 – 2.15 (67 – 54)
		H	—	—	—	—	—	—	2.68 – 2.34 (68 – 59)
		J	—	—	—	—	—	—	2.68 – 2.53 (68 – 64)

Note: All levels ±0.25" (6).

## 4.3 Specifications

### 4.3.6 Model B10 Actuating Levels (cont.)

Inches (mm)

B10 Standard actuating levels and liquid specific gravity with displacer arrangements 3, 4, and 5 (cont.)

Displacer Type	Liquid Temp. ° F	Level	1.08 – 1.12	1.13 – 1.17	1.18 – 1.27	1.28 – 1.30	1.31 – 1.39	1.40 – 1.50
Porcelain	+100	G	1.16 – 0.89 (29 – 22)	2.04 – 1.75 (51 – 44)	1.68 – 1.10 (42 – 27)	1.04 – 0.92 (26 – 23)	2.05 – 1.56 (52 – 39)	1.50 – 0.97 (38 – 24)
		H	1.22 – 1.06 (30 – 26)	1.78 – 1.61 (45 – 40)	1.57 – 1.23 (39 – 31)	1.19 – 1.12 (30 – 28)	1.49 – 1.21 (37 – 30)	1.18 – 0.89 (29 – 22)
		J	0.96 – 0.92 (24 – 23)	0.92 – 0.88 (23 – 22)	0.88 – 0.81 (22 – 20)	0.81 – 0.80 (20 – 20)	0.79 – 0.74 (20 – 18)	0.74 – 0.69 (18 – 17)
	+200	G	1.68 – 1.38 (42 – 35)	1.31 – 1.05 (33 – 26)	1.71 – 1.13 (43 – 28)	1.75 – 1.62 (44 – 41)	1.56 – 1.09 (39 – 27)	1.53 – 1.00 (38 – 25)
		H	1.42 – 1.25 (36 – 31)	1.21 – 1.06 (30 – 26)	1.31 – 0.99 (33 – 25)	1.50 – 1.42 (38 – 36)	1.39 – 1.12 (35 – 28)	1.33 – 1.03 (33 – 26)
		J	1.48 – 1.42 (37 – 36)	1.41 – 1.36 (35 – 34)	1.35 – 1.25 (34 – 31)	1.24 – 1.23 (31 – 31)	1.22 – 1.15 (30 – 29)	1.14 – 1.06 (28 – 26)
	+300	G	2.19 – 1.88 (55 – 47)	1.81 – 1.52 (45 – 38)	2.19 – 1.57 (55 – 39)	2.18 – 2.05 (50 – 37)	1.98 – 1.49 (50 – 37)	1.93 – 1.37 (49 – 34)
		H	1.93 – 1.75 (49 – 44)	1.70 – 1.53 (43 – 38)	1.79 – 1.43 (45 – 36)	1.93 – 1.85 (49 – 46)	1.81 – 1.52 (45 – 38)	1.73 – 1.40 (43 – 35)
		J	1.99 – 1.92 (50 – 48)	1.90 – 1.84 (48 – 46)	1.82 – 1.69 (45 – 42)	1.68 – 1.66 (42 – 42)	1.64 – 1.55 (41 – 39)	1.54 – 1.43 (39 – 36)
	+400	G	2.71 – 2.38 (68 – 60)	2.30 – 2.00 (58 – 50)	2.66 – 2.01 (67 – 51)	2.62 – 2.48 (61 – 48)	2.41 – 1.90 (61 – 48)	2.33 – 1.74 (59 – 44)
		H	2.45 – 2.25 (62 – 57)	2.20 – 2.01 (55 – 51)	2.26 – 1.87 (57 – 47)	2.37 – 2.28 (60 – 57)	2.24 – 1.92 (56 – 23)	2.13 – 1.77 (54 – 44)
		J	2.51 – 2.42 (63 – 61)	2.40 – 2.32 (60 – 58)	2.30 – 2.13 (58 – 54)	2.12 – 2.08 (53 – 52)	2.07 – 1.95 (52 – 49)	1.94 – 1.81 (49 – 45)
	+500	G	3.23 – 2.88 (82 – 73)	2.80 – 2.48 (71 – 62)	3.13 – 2.45 (79 – 62)	3.05 – 2.91 (77 – 73)	2.84 – 2.30 (72 – 58)	2.73 – 2.11 (69 – 53)
		H	2.97 – 2.75 (75 – 69)	2.69 – 2.49 (68 – 63)	2.73 – 2.31 (69 – 58)	2.80 – 2.71 (71 – 68)	2.67 – 2.33 (67 – 59)	2.53 – 2.15 (64 – 54)
		J	3.03 – 2.92 (76 – 74)	2.89 – 2.79 (73 – 70)	2.77 – 2.57 (70 – 65)	2.55 – 2.51 (64 – 63)	2.50 – 2.35 (63 – 59)	2.33 – 2.18 (59 – 55)

Note: All levels  $\pm 0.25$ " (6).

## 4.3 Specifications

### 4.3.6 Model B10 Actuating Levels (cont.)

Inches (mm)

**B10 Standard actuating levels and liquid specific gravity with displacer arrangements 3, 4, and 5**

Displacer Type	Liquid Temp. ° F	Level	0.50 – 0.58	0.59 – 0.71	0.72 – 0.79	0.80 – 0.85	0.86 – 1.00	1.01 – 1.03
Stainless Steel and Karbate	+100	G	3.77 – 1.60 (95 – 40)	4.10 – 1.38 (104 – 35)	4.43 – 2.97 (112 – 75)	4.58 – 3.60 (24 – 91)	3.42 – 1.26 (86 – 31)	1.13 – 0.88 (28 – 22)
		H	3.46 – 2.16 (87 – 54)	3.72 – 2.08 (94 – 52)	3.96 – 3.07 (100 – 77)	3.63 – 3.07 (92 – 77)	2.96 – 1.71 (75 – 43)	1.45 – 1.31 (36 – 33)
		J	2.51 – 2.16 (63 – 54)	2.13 – 1.77 (54 – 44)	1.74 – 1.59 (44 – 40)	1.57 – 1.48 (39 – 37)	1.46 – 1.25 (37 – 31)	1.24 – 1.22 (31 – 30)
	+200	G	4.22 – 1.98 (107 – 50)	1.74 – 1.44 (44 – 36)	3.74 – 2.35 (94 – 59)	2.17 – 1.33 (55 – 33)	3.89 – 1.66 (98 – 42)	—
		H	3.76 – 2.42 (95 – 61)	2.27 – 1.89 (57 – 48)	3.02 – 2.22 (76 – 56)	2.12 – 1.64 (53 – 41)	3.22 – 1.93 (81 – 49)	—
		J	3.67 – 3.16 (93 – 80)	3.11 – 2.58 (78 – 65)	2.55 – 2.32 (64 – 58)	2.29 – 2.16 (58 – 54)	2.13 – 1.84 (54 – 46)	—
	+300	G	—	4.87 – 2.26 (123 – 57)	4.55 – 3.08 (115 – 78)	2.89 – 2.02 (73 – 51)	4.56 – 2.24 (115 – 56)	—
		H	—	4.30 – 2.70 (109 – 68)	3.83 – 2.96 (97 – 75)	2.84 – 2.32 (72 – 58)	3.89 – 2.51 (98 – 63)	—
		J	—	4.03 – 3.40 (102 – 86)	3.36 – 3.06 (85 – 77)	3.02 – 2.84 (76 – 72)	2.81 – 2.42 (71 – 61)	—
Stainless Steel	+400	G	—	—	5.35 – 3.82 (135 – 97)	3.62 – 2.70 (91 – 68)	5.24 – 2.82 (133 – 71)	—
		H	—	—	4.63 – 3.69 (117 – 93)	3.57 – 3.01 (90 – 76)	4.57 – 3.09 (116 – 78)	—
		J	—	—	4.16 – 3.79 (105 – 96)	3.75 – 3.53 (95 – 89)	3.48 – 3.00 (88 – 76)	—
	+500	G	—	—	—	—	5.91 – 3.41 (150 – 86)	—
		H	—	—	—	—	5.24 – 3.67 (133 – 93)	—
		J	—	—	—	—	4.16 – 3.58 (105 – 90)	—

Note: All levels ±0.25" (6).

## 4.3 Specifications

### 4.3.7 Model B15 Dimensional Data

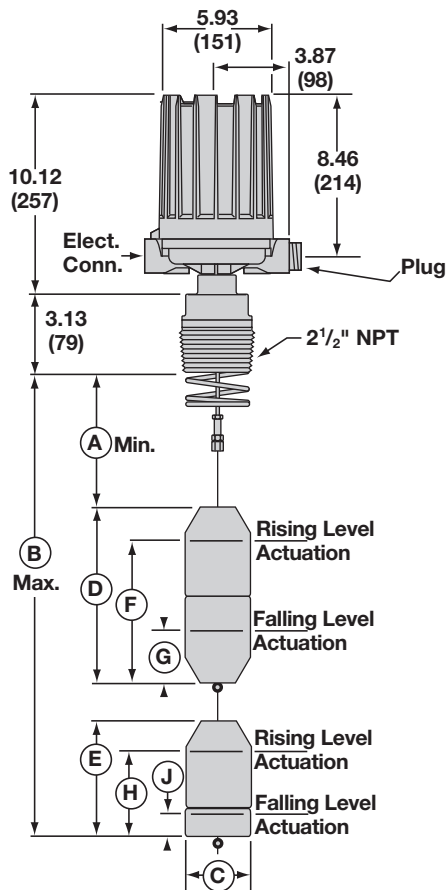
Inches (mm)

#### Model B15

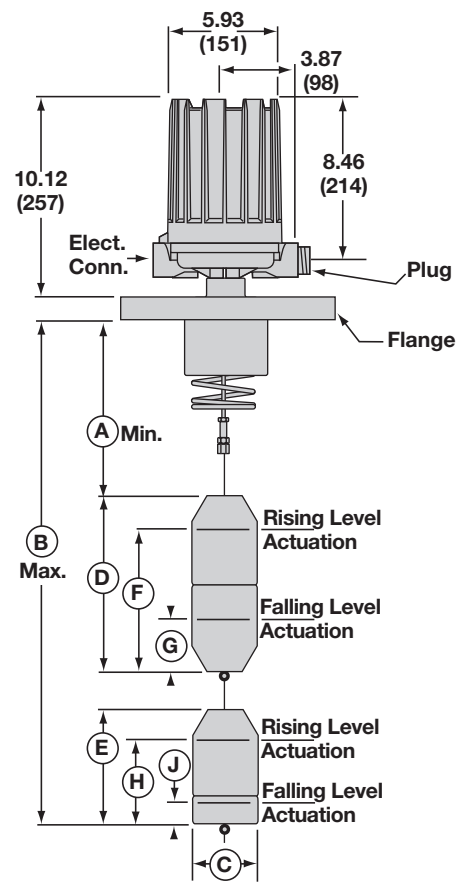
Displacer Type	Outline Dimensions			
	Threaded Mounting		Flanged Mounting	
	A	B	A	B
Porcelain	5.50 (139)	243.00 (6172)	7.50 (190)	245.00 (6223)
Stainless Steel or Karbate	5.88 (149)	243.00 (6172)	7.88 (200)	245.00 (6223)

Displacer Type	C	D	E
Porcelain	2.56 (65)	7.25 (184)	5.02 (127)
Stainless Steel or Karbate	2.50 (63)	10.50 (266)	6.00 (152)

Electrical Connections
NEMA 4X/7/9 Group B: 1" NPT



**Model B15**  
with Threaded Mounting



**Model B15**  
with Flanged Mounting



## 4.3 Specifications

### 4.3.8 Model B15 Actuating Levels\*

Inches (mm)

#### B15 Standard actuating levels and liquid specific gravity

Displacer Type	Liquid Temp. °F	0.70				0.80			
		F	G	H	J	F	G	H	J
Stainless Steel or Karbate	+100	9.50 (241)	5.00 (127)	4.90 (124)	1.30 (33)	7.60 (193)	3.70 (93)	4.30 (109)	1.10 (27)
	+200	—	—	—	—	8.20 (208)	4.30 (109)	5.00 (127)	1.80 (45)

Displacer Type	Liquid Temp. °F	0.95				1.00			
		F	G	H	J	F	G	H	J
Porcelain	+100	5.50 (139)	2.00 (50)	3.70 (93)	1.00 (25)	5.00 (127)	1.70 (43)	3.50 (88)	0.80 (20)
Stainless Steel	+100	5.50 (139)	2.00 (50)	3.70 (93)	1.00 (25)	4.90 (124)	1.70 (43)	3.40 (86)	0.90 (22)
	+200	6.00 (152)	2.70 (68)	4.20 (106)	1.50 (38)	5.40 (137)	2.20 (55)	4.00 (101)	1.50 (38)
	+300	6.40 (162)	3.10 (78)	4.70 (119)	2.00 (50)	5.70 (144)	2.50 (63)	4.40 (111)	1.90 (48)
	+400	—	—	—	—	6.10 (154)	2.90 (73)	4.90 (124)	2.40 (60)
Karbate	+100	5.50 (139)	2.00 (50)	3.70 (93)	1.00 (25)	4.90 (124)	1.70 (43)	3.40 (86)	0.90 (22)
	+200	6.00 (152)	2.70 (68)	4.20 (106)	1.50 (38)	5.40 (137)	2.20 (55)	4.00 (101)	1.50 (38)
	+300	6.40 (162)	3.10 (78)	4.70 (119)	2.00 (50)	5.70 (144)	2.50 (63)	4.40 (111)	1.90 (48)

Note: All levels  $\pm 0.25"$  (6).

\*See pages 31 and 32 for Proof-er and/or Floating roof top switch dimensions.

## 4.3 Specifications

### 4.3.9 Model C10 Dimensional Data

Inches (mm)

#### Model C10 with all displacer arrangements

Displacer Type	Outline Dimensions			
	Threaded Mounting		Flanged Mounting	
	A	B	A	B
Porcelain	6.38 (965)	243.00 (6172)	8.38 (212)	245.00 (6223)
Stainless Steel or Karbate	5.75 (146)	243.00 (6172)	7.75 (196)	245.00 (6223)

#### Model C10 with displacer arrangements A, B, and C

Displacer Type	C	D	E	F	G
Porcelain	2.56 (65)	6.42 (163)	5.02 (127)	5.02 (127)	3.62 (91)
Stainless Steel or Karbate	2.50 (63)	6.00 (152)	6.00 (152)	4.50 (114)	4.50 (114)

#### Model C10 with displacer arrangements D and F

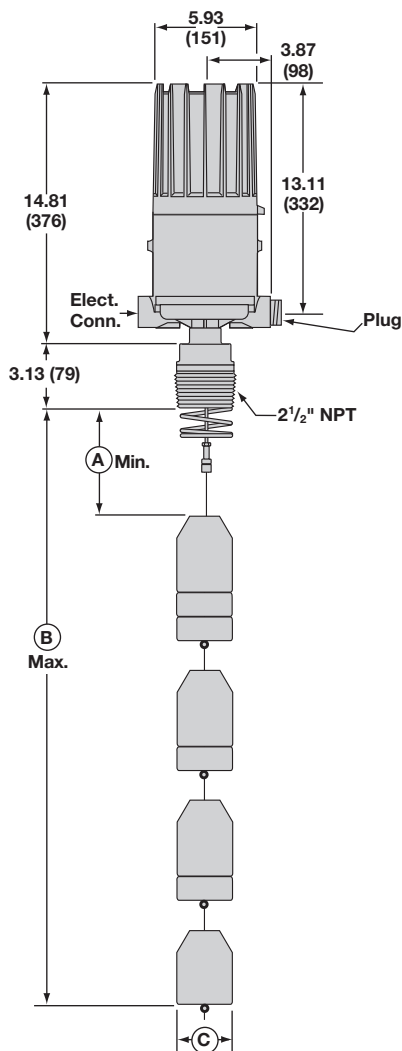
Displacer Type	C	D	E	F
Porcelain	2.56 (65)	14.44 (367)	5.02 (127)	3.62 (91)
Stainless Steel or Karbate	2.50 (63)	12.00 (304)	4.50 (114)	4.50 (114)

#### Model C10 with displacer arrangements E and G

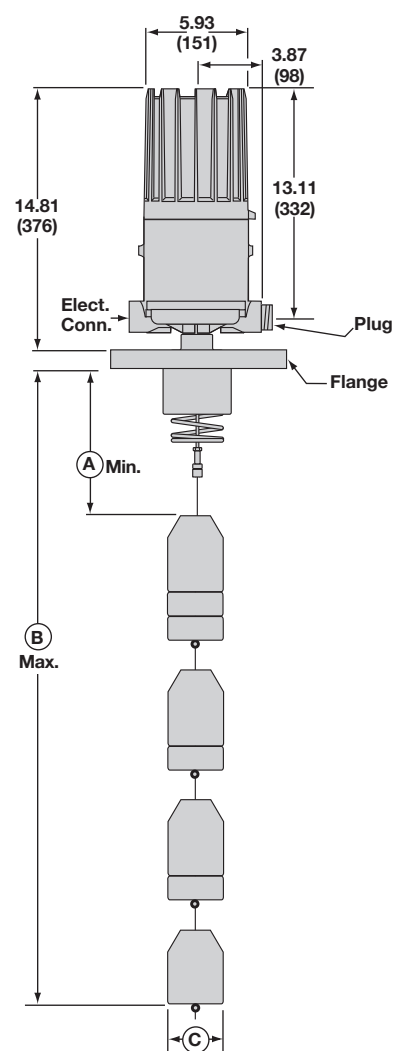
Displacer Type	C	D	E	F
Porcelain	2.56 (65)	6.42 (153)	5.02 (127)	8.65 (219)
Stainless Steel or Karbate	2.50 (63)	6.00 (152)	6.00 (152)	9.00 (228)

#### Electrical Connections

NEMA 4X/7/9  
Group B: 1" NPT



**Model C10**  
with Threaded Mounting

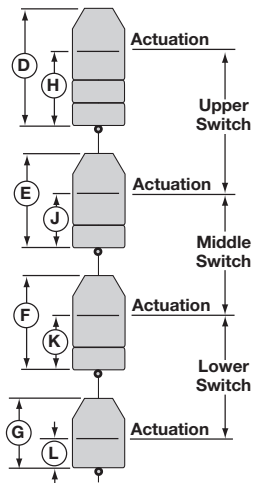


**Model C10**  
with Flanged Mounting

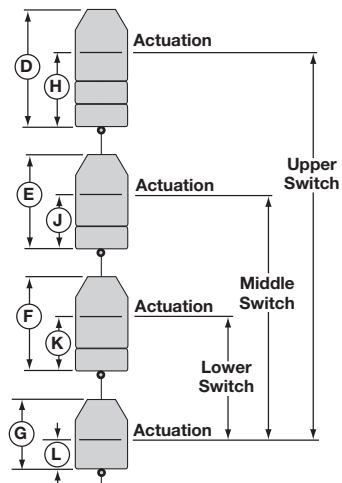
## 4.3 Specifications

### 4.3.10 Model C10 Actuating Levels

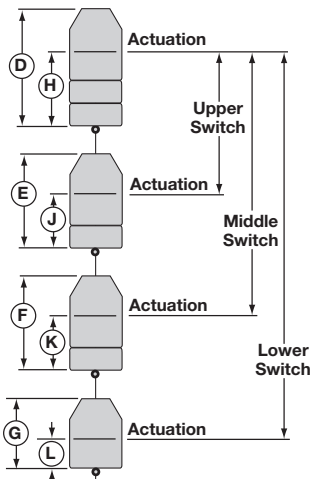
Inches (mm)



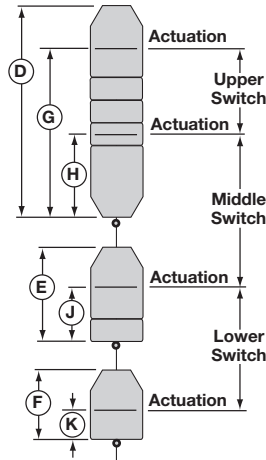
**Model C10**  
**Displacer Arrangement A**



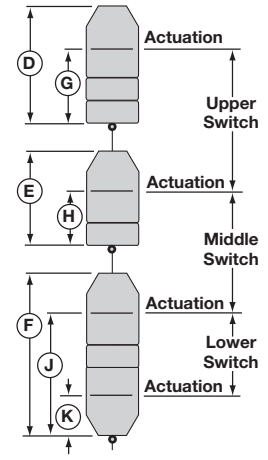
**Model C10**  
**Displacer Arrangement B**



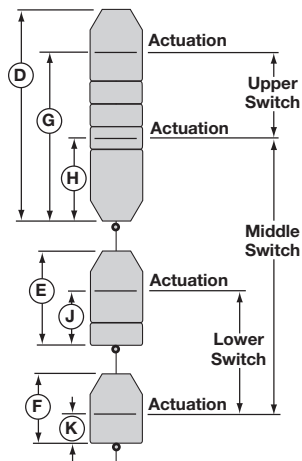
**Model C10**  
**Displacer Arrangement C**



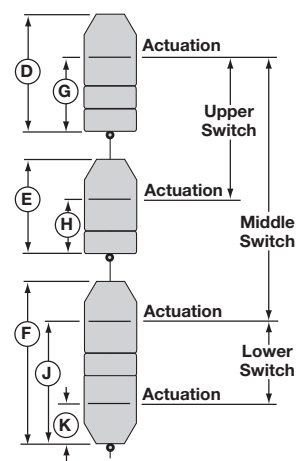
**Model C10**  
**Displacer Arrangement D**



**Model C10**  
**Displacer Arrangement E**



**Model C10**  
**Displacer Arrangement F**



**Model C10**  
**Displacer Arrangement G**

## 4.3 Specifications

### 4.3.10 Model C10 Actuating Levels (cont.)

Inches (mm)

#### C10 Standard actuating levels and liquid specific gravity with displacer arrangements A, B, and C

Displacer Type	Liquid Temp. °F	0.58				0.60				0.70				0.80			
		H	J	K	L	H	J	K	L	H	J	K	L	H	J	K	L
Porcelain	+100	—	—	—	—	—	—	—	—	2.50 (63)	2.20 (55)	2.20 (55)	2.00 (50)	2.30 (58)	2.00 (50)	1.90 (48)	1.70 (43)
Stainless Steel or Karbate	+100	4.50 (114)	3.70 (93)	3.20 (81)	2.30 (58)	3.80 (96)	3.20 (81)	3.00 (76)	2.20 (55)	4.20 (106)	3.80 (96)	2.10 (53)	1.90 (48)	1.80 (45)	2.20 (55)	1.30 (33)	1.70 (43)
	+200	—	—	—	—	—	—	—	—	—	—	—	—	3.20 (81)	2.90 (73)	2.50 (63)	2.30 (58)

Note: All levels ±0.25" (6).

Displacer Type	Liquid Temp. °F	0.90				1.00				1.10				1.20			
		H	J	K	L	H	J	K	L	H	J	K	L	H	J	K	L
Porcelain	+100	3.0 (76)	2.4 (61)	2.7 (69)	1.5 (38)	1.4 (36)	1.4 (36)	2.1 (53)	1.4 (36)	3.0 (76)	2.6 (66)	2.5 (64)	1.2 (30)	1.7 (43)	1.7 (43)	2.1 (53)	1.1 (28)
	+200	—	—	—	—	3.2 (81)	2.7 (69)	2.8 (71)	1.7 (43)	1.7 (43)	1.7 (43)	2.3 (58)	1.6 (41)	—	—	—	—
Stainless Steel or Karbate	+100	3.1 (79)	3.2 (81)	2.5 (64)	1.5 (38)	1.3 (33)	1.9 (48)	1.8 (46)	1.3 (33)	3.1 (79)	3.2 (81)	2.5 (64)	1.3 (33)	1.6 (41)	2.2 (56)	1.9 (48)	1.2 (30)
	+200	3.6 (91)	3.6 (91)	1.7 (43)	2.0 (51)	1.7 (43)	2.3 (58)	1.1 (28)	1.8 (46)	—	—	—	—	—	—	—	—
	+300	3.4 (86)	3.0 (76)	2.4 (61)	2.7 (69)	1.6 (41)	1.8 (46)	1.7 (43)	2.4 (61)	—	—	—	—	—	—	—	—

Note: All levels ±0.25" (6).

#### C10 Standard actuating levels and liquid specific gravity with displacer arrangements D and F

Displacer Type	Liquid Temp. °F	0.58				0.60				0.70				0.80			
		H	J	K	L	H	J	K	L	H	J	K	L	H	J	K	L
Porcelain	+100	—	—	—	—	—	—	—	—	7.50 (190)	2.60 (66)	2.20 (55)	2.00 (50)	6.90 (175)	2.40 (60)	1.90 (48)	1.70 (43)
Stainless Steel or Karbate	+100	9.90 (251)	3.70 (93)	3.20 (81)	2.30 (58)	9.20 (233)	3.20 (81)	3.00 (76)	2.20 (55)	8.90 (226)	3.80 (96)	2.10 (53)	1.90 (48)	6.70 (170)	2.20 (55)	1.30 (33)	1.70 (43)
	+200	—	—	—	—	—	—	—	—	—	—	—	—	7.40 (187)	2.90 (73)	2.50 (63)	2.30 (58)

Note: All levels ±0.25" (6).

Displacer Type	Liquid Temp. °F	0.90				1.00				1.10				1.20			
		H	J	K	L	H	J	K	L	H	J	K	L	H	J	K	L
Porcelain	+100	6.60 (167)	2.80 (71)	2.70 (68)	1.50 (38)	5.20 (132)	1.80 (45)	2.10 (53)	1.40 (35)	6.10 (154)	3.00 (76)	2.50 (63)	1.20 (30)	5.00 (127)	2.10 (53)	2.10 (53)	1.10 (27)
	+200	—	—	—	—	6.20 (157)	3.10 (78)	2.80 (71)	1.70 (43)	5.20 (132)	2.10 (53)	2.30 (58)	1.60 (40)	—	—	—	—
Stainless Steel or Karbate	+100	7.20 (182)	3.20 (81)	2.50 (63)	1.50 (38)	5.50 (139)	1.90 (48)	1.80 (45)	1.30 (33)	6.40 (162)	3.20 (81)	2.50 (63)	1.30 (33)	5.20 (132)	2.20 (55)	1.90 (48)	1.20 (30)
	+200	7.60 (193)	3.60 (91)	1.70 (43)	2.00 (50)	5.90 (149)	2.30 (58)	1.10 (27)	1.80 (45)	—	—	—	—	—	—	—	—
	+300	7.00 (177)	3.00 (76)	2.40 (60)	2.70 (68)	5.40 (137)	1.80 (45)	1.70 (43)	2.40 (60)	—	—	—	—	—	—	—	—

Note: All levels ±0.25" (6).

## 4.3 Specifications

### 4.3.10 Model C10 Actuating Levels (cont.)

Inches (mm)

#### C10 Standard actuating levels and liquid specific gravity with displacer arrangements E and G

Displacer Type	Liquid Temp. °F	0.58				0.60				0.70				0.80			
		H	J	K	L	H	J	K	L	H	J	K	L	H	J	K	L
Porcelain	+100	—	—	—	—	—	—	—	—	2.50 (63)	2.20 (55)	5.80 (147)	1.90 (48)	2.30 (58)	2.00 (50)	5.50 (139)	2.10 (53)
Stainless Steel or Korbate	+100	4.50 (114)	3.70 (93)	7.70 (195)	2.80 (71)	3.80 (96)	3.20 (81)	7.50 (190)	2.70 (68)	4.20 (106)	3.80 (96)	6.60 (167)	2.50 (63)	1.80 (45)	2.20 (55)	5.80 (147)	2.20 (55)
	+200	—	—	—	—	—	—	—	—	—	—	—	—	3.20 (81)	2.90 (73)	7.00 (177)	3.40 (86)

Note: All levels  $\pm 0.25$ " (6).

Displacer Type	Liquid Temp. °F	0.90				1.00				1.10				1.20			
		H	J	K	L	H	J	K	L	H	J	K	L	H	J	K	L
Porcelain	+100	3.00 (76)	2.40 (60)	6.30 (160)	3.20 (81)	1.40 (35)	1.40 (35)	5.70 (144)	1.90 (48)	3.00 (76)	2.60 (66)	6.10 (154)	3.60 (91)	1.70 (43)	1.70 (43)	5.70 (144)	3.40 (86)
	+200	—	—	—	—	3.20 (81)	2.70 (68)	6.40 (162)	3.60 (91)	1.70 (43)	1.70 (43)	5.90 (149)	3.40 (86)	—	—	—	—
Stainless Steel or Korbate	+100	3.10 (78)	3.20 (81)	7.00 (177)	3.80 (96)	1.30 (33)	1.90 (48)	6.30 (160)	3.40 (86)	3.10 (78)	3.20 (81)	7.00 (177)	4.40 (111)	1.60 (40)	2.20 (55)	6.40 (162)	4.00 (101)
	+200	3.60 (91)	3.60 (91)	6.20 (157)	3.00 (76)	1.70 (43)	2.30 (58)	5.60 (142)	2.70 (68)	—	—	—	—	—	—	—	—
	+300	3.40 (86)	3.00 (76)	6.90 (175)	3.70 (93)	1.60 (40)	1.80 (45)	6.20 (157)	3.30 (83)	—	—	—	—	—	—	—	—

Note: All levels  $\pm 0.25$ " (6).

## 4.3 Specifications

### 4.3.11 Model C15 Dimensional Data

Inches (mm)

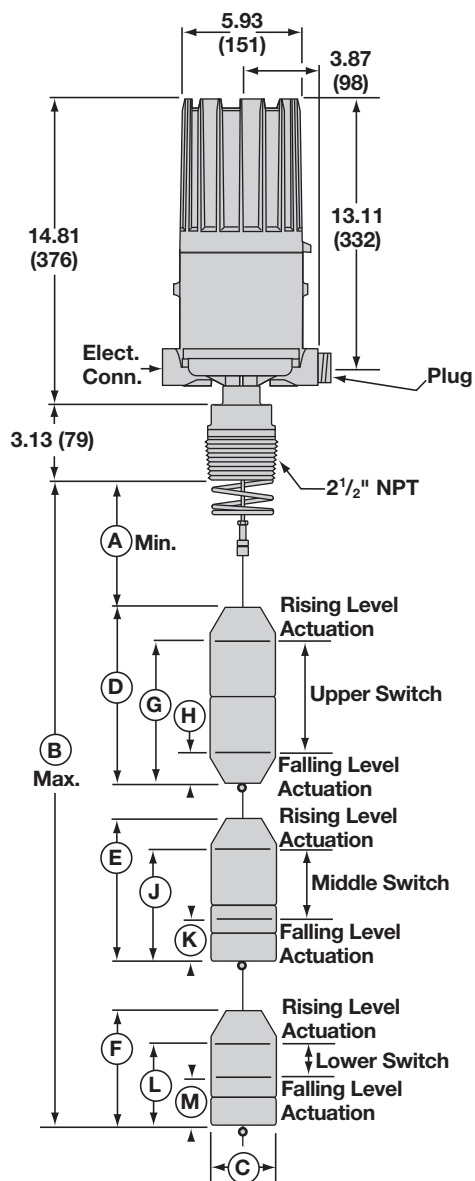
#### Model C15

Displacer Type	OUTLINE DIMENSIONS			
	Threaded Mounting		Flanged Mounting	
	A	B	A	B
Porcelain	7.75 (196)	245.00 (6223)	9.75 (247)	247.00 (6273)
Stainless Steel or Karbate	7.25 (184)	244.00 (6197)	9.25 (234)	246.00 (6248)

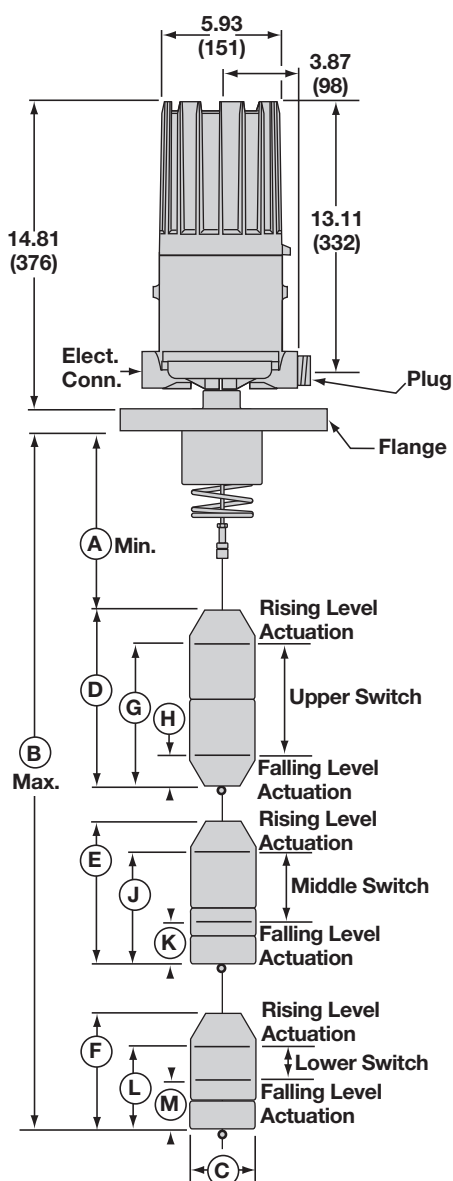
Displacer Type	C	D	E	F
Porcelain	2.56 (65)	7.25 (184)	6.42 (163)	5.02 (127)
Stainless Steel or Karbate	2.50 (63)	9.00 (228)	7.50 (190)	6.00 (152)

#### Electrical Connections

NEMA 4X/7/9  
Group B: 1" NPT



**Model C15**  
with Threaded Mounting



**Model C15**  
with Flanged Mounting

## 4.3 Specifications

### 4.3.12 Model C15 Actuating Levels

Inches (mm)

C15 Standard actuating levels and liquid specific gravity

Displacer Type	Liquid Temp. °F	0.65						0.70						0.80					
		G	H	J	K	L	M	G	H	J	K	L	M	G	H	J	K	L	M
Porcelain	0 to +130	—	—	—	—	—	—	—	—	—	—	—	—	6.20 (157)	1.40 (35)	5.30 (134)	1.00 (25)	3.80 (96)	0.90 (22)
Stainless Steel or Karbate	0 to +130	7.70 (195)	2.20 (55)	6.10 (154)	2.00 (50)	4.90 (124)	1.40 (35)	6.70 (170)	1.60 (40)	5.50 (139)	1.60 (40)	4.60 (116)	1.30 (33)	6.50 (165)	2.00 (50)	5.20 (132)	1.60 (40)	4.30 (109)	1.10 (27)

Note: All levels ±0.25" (6).

Displacer Type	Liquid Temp. °F	0.90						1.00						1.10					
		G	H	J	K	L	M	G	H	J	K	L	M	G	H	J	K	L	M
Porcelain	0 to +130	6.20 (157)	1.90 (48)	5.00 (127)	1.40 (35)	3.60 (91)	1.00 (25)	4.60 (116)	0.70 (17)	4.00 (101)	0.80 (20)	3.30 (83)	0.90 (22)	4.20 (106)	1.10 (27)	3.80 (96)	1.00 (25)	3.10 (78)	0.90 (22)
Stainless Steel or Karbate	0 to +130	6.60 (167)	2.60 (66)	5.20 (132)	1.80 (45)	4.00 (101)	1.20 (30)	4.60 (116)	1.00 (25)	4.00 (101)	1.00 (25)	3.60 (91)	1.10 (27)	—	—	—	—	—	—

Note: All levels ±0.25" (6).

Displacer Type	Liquid Temp. °F	1.20						1.25					
		G	H	J	K	L	M	G	H	J	K	L	M
Porcelain	0 to +130	4.50 (114)	1.60 (40)	3.70 (93)	1.10 (27)	2.90 (73)	0.90 (22)	3.90 (99)	1.10 (27)	3.30 (83)	0.90 (22)	2.80 (71)	0.80 (20)

Note: All levels ±0.25" (6).

## 4.3 Specifications

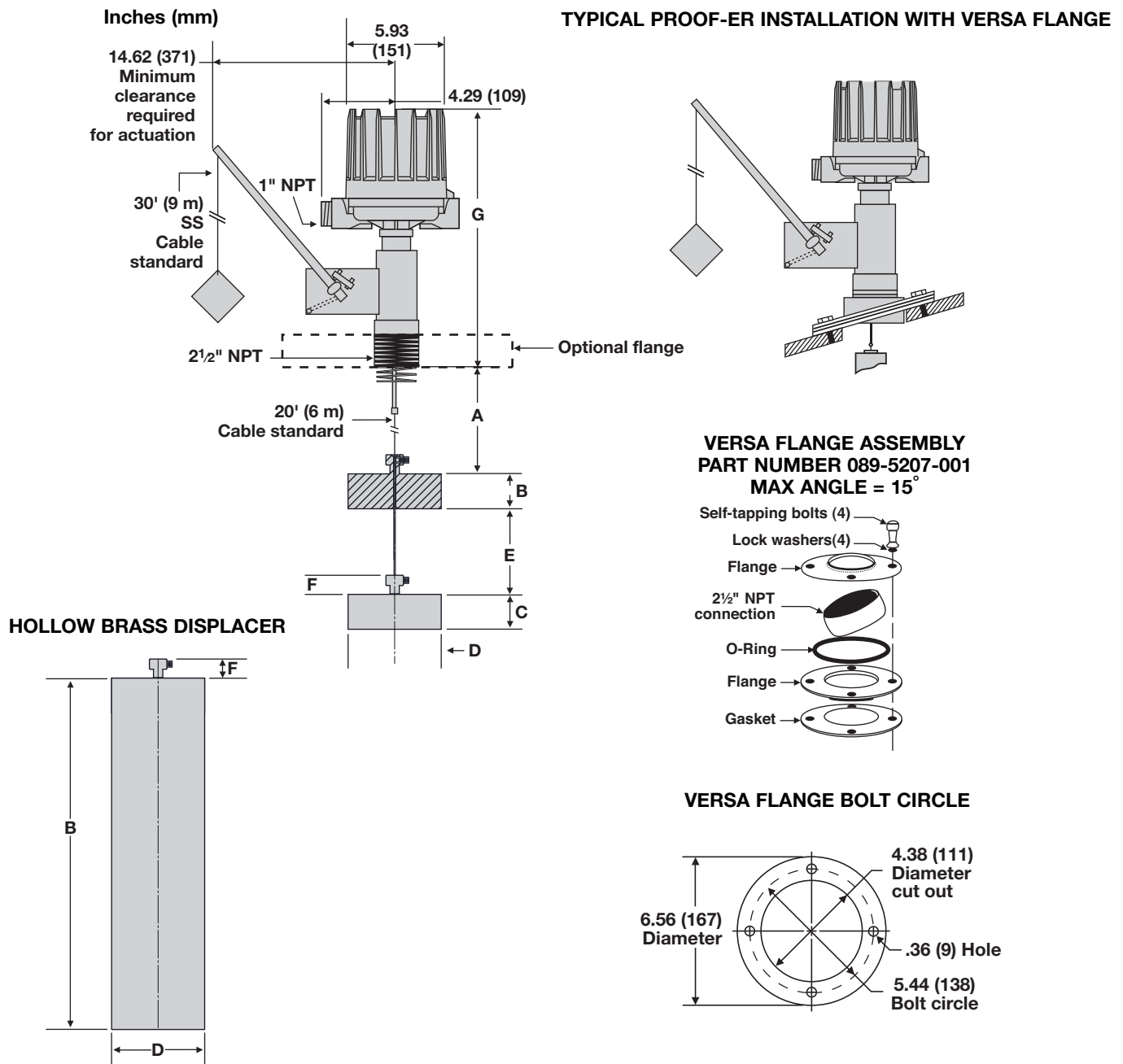
### 4.3.13 Proof-er Dimensional Data

Dimensional Chart inches (mm)

		A	B	C	D	E min	F	G	
A15	Threaded	5.62	n/a						15.93 (405)
	Flanged	7.62	n/a						17.62 (448)
	SS Chunk	n/a	1.50 (38)	n/a	3.00 (76)	n/a	0.82 (21)	n/a	
	Brass Chunk		1.50 (38)		2.88 (73)		0.82 (21)		
	Hollow Brass		9.00 (229)		2.50 (64)		0.92 (23)		
B15	Threaded	5.88	n/a						18.12 (460)
	Flanged	7.88	n/a						19.81 (503)
	SS Chunk	n/a	1.50 (38)	0.75 (19)	3.00 (76)	4.00 (102)	0.82 (21)	n/a	
	Brass Chunk		1.12 (28)	0.75 (19)	2.88 (73)		0.82 (21)		
	Hollow Brass		n/a						

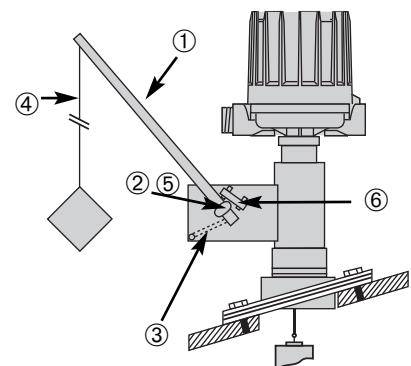
## 4.3 Specifications

### 4.3.13 Proof-er Dimensional Data



### 4.3.14 Proof-er Replacement Parts

		Proof-er Replacement Part Number	
Item	Description	Low Pressure	Medium Pressure
1	Handle	004-4011-001	004-0490-001
2	O-Ring	Not Required	012-2205-001
3	Spring	013-2502-001	
4	Cable Assembly	089-5807-001	
5	O-Ring Cover	Not Required	004-0489-001
6	Nut	010-2107-004	Not Required





## 4.4 Replacement Parts<sup>①</sup>

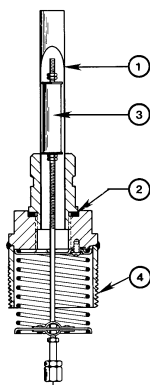
Item No.	Description		A10	A15	B10/B15	C10/C15
1	Enclosing Tube Kit <sup>②</sup>	Standard	089-5933-007	089-5933-001	089-5933-007	089-5959-003
		316 SS	089-5933-008	089-5933-002	089-5933-008	089-5959-020
2	E-Tube Gasket		012-1204-001			
3	Spring and Stem Kit <sup>③</sup>	Standard	089-5327-001	089-5325-001	n/a <sup>④</sup>	
		316 SS	089-5328-001	089-5326-001	n/a <sup>④</sup>	
4	Body Bushing		089-5707-001			
5	Flange and Spring Protector		Specify size and rating. Furnish serial number of control.			

① For models with proofer option or for floating roof detection, consult factory for these replacement parts.

② Enclosing Tube Kit includes E-Tube Gasket 012-1204-001.

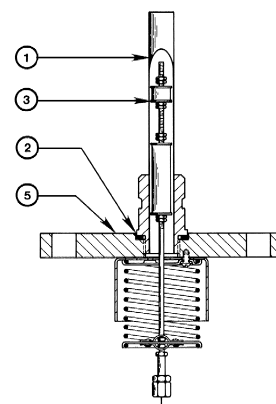
③ 316 SS Spring and Stem Kit includes 316 SS sheathed magnetic sleeve.

④ Unit must be returned to factory for repair and recalibration.



**Threaded Connection Model**  
(Typical Single Switch Model)

**Flanged Connection Model**  
(Typical Dual Switch Model)



**CAUTION:**

Location of magnetic sleeve must be maintained for proper switch actuation. Do NOT attempt to alter differential of control by repositioning jam nuts.

### 4.4.1 Displacer Replacement Parts

Displacer Material		A10	A15	B10	B15	C10	C15	
Porcelain <sup>⑤</sup>		089-6141-001	089-6142-001	089-6143-001	089-6144-001	089-6153-001	089-6156-001	
Karbate <sup>⑤</sup>		089-6145-001	089-6146-001	089-6147-001	089-6148-001	089-6154-001	089-6157-001	
Stainless Steel <sup>⑤</sup>		089-6149-001	089-6150-001	089-6151-001	089-6152-001	089-6155-001	089-6158-001	
Brass Chunk <sup>⑦</sup>		N/A	089-6177-004	N/A	089-6177-005	N/A	N/A	
Hollow Brass <sup>⑧</sup>		N/A	089-6177-001	N/A	N/A	N/A	N/A	
20 feet (6m) Cable	316 SS						089-5802-003 <sup>⑥</sup>	
with Displacer	Hastelloy						089-5803-003 <sup>⑥</sup>	
Clamps only	Monel						089-5804-003 <sup>⑥</sup>	

⑤ Kits contain 20 feet (6m) 316 SS cable.

⑥ For Model C10 with operating sequences A, B, or C order kits: 089-5802-004 (316 SS), 089-5803-004 (Hastelloy), or 089-5804-004 (Monel).

**NOTE:** Refer to pages 14, 15, 16, 24, 26 & 30 for dimensional specifications of displacers.

⑦ Brass chunk displacer kits may be used as replacements for lead chunk displacers.

⑧ Consult factory when changing from a brass chunk displacer to a hollow brass displacer.

## 4.5 Model Numbers

### 4.5.1 A10 & A15 Single Switch Models

#### PART NUMBER CODE AND SPECIFIC GRAVITY LIMITS\*

Part Number Code	Function	Liquid Temp.		Displacer Type		
		°F	°C	Porcelain	Stainless Steel	Karbate
A10	Wide Differential, Single Stage	100	38	0.60 to 1.20	0.60 to 1.20	0.60 to 1.20
		200	93	0.70 to 1.20	0.70 to 1.20	0.70 to 1.20
		300	149	0.80 to 1.20	0.80 to 1.20	0.80 to 1.20
		400	204	1.00 to 1.20	0.90 to 1.20	—
		500	260	1.10 to 1.20	1.00 to 1.20	—
A15	Narrow Differential, Single Stage	100	38	0.60 to 2.40	0.40 to 1.65	0.40 to 1.65
		200	93	0.62 to 2.40	0.40 to 1.65	0.45 to 1.65
		300	149	0.65 to 2.40	0.50 to 1.65	0.50 to 1.65
		400	204	0.70 to 2.40	0.55 to 1.65	—
		500	260	0.75 to 2.40	0.60 to 1.65	—

#### MATERIALS OF CONSTRUCTION

Code	Support Spring	Trim	E-Tube Mtg. Nut	Displacer Clamps/ Susp. Cable	Magnetic Sleeve	Process Connection
1	Inconel 600	300 Series SS	Carbon Steel	316 SS	400 Series SS	Carbon Steel
2	Inconel 600	316 SS	316 SS	316 SS	316 SS	Carbon Steel
4						316 SS
5	Inconel 600	300 Series SS	Carbon Steel	Monel	400 Series SS	Carbon Steel
6				Hastelloy		
M ① NACE Const.	Inconel X750	316 SS	316 SS	316 SS	316 SS	316 SS
N ① NACE Const.	Inconel X750	300 Series SS	316 SS	316 SS	316 SS	Carbon Steel

#### TANK CONNECTION

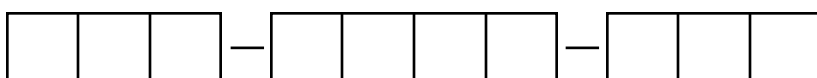
Tank Connection	Code
2½" NPT Threaded ②	E2
3" 150 lb. Flat Face Flange ③④⑩	G2
3" 150 lb. Raised Face Flange ⑤	G3
4" 150 lb. Flat Face Flange ③④⑩	H2
4" 150 lb. Raised Face Flange ⑤	H3
4" 300 lb. Raised Face Flange ⑤	H4
6" 150 lb. Flat Face Flange ③④⑩	K2
6" 150 lb. Raised Face Flange ⑤	K3
6" 300 lb. Raised Face Flange ⑤	K4

#### DISPLACER MATERIAL AND PROOF-ER OPTION

Proof-er** Type	Displacer			Floating Roof Weight ④	Liquid & Floating Roof Displacer
	Porcelain	316 SS	Karbate	Brass	Hollow Brass ③
Without Proof-er	A	B	C	P ③	R ③
Low Pressure ②	D ③	E ③	F ③	Q ③	T ③
Medium Pressure ②	G ③	H ③	J ③	—	—

\* Specific gravity limits do not apply to floating roof top units not to be used in liquid.

\*\* Proof-er option constructed of carbon steel material.



## 4.5 Model Numbers

### 4.5.1 A10 & A15 Single Switch Models (continued)

#### ELECTRIC SWITCH MECHANISM AND ENCLOSURE ⑥

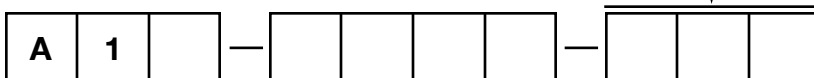
Switch Description	Max. ⑦ Process Temp. °F (°C)	One Set Point	A10 Codes			A15 Codes		
			Aluminum Polymer Coated NEMA 4X/7/9 ⑧					
			Class I,,Div. 1, Groups C & D	Class I,,Div. 1, Group B	ATEX	Class I,,Div. 1, Groups C & D	Class I,,Div. 1, Group B	ATEX
Series B Snap Switch	250 (121)	SPDT	BKB	BKK	BC9	BKQ	BKS	BA9
		DPDT	BNB	BNK	BF9	BNQ	BNS	BB9
Series C Snap Switch	450 (232)	SPDT	CKB	CKK	CC9	CKQ	CKS	CA9
		DPDT	CNB	CNK	CF9	CNQ	CNS	CB9
Series D Snap Switch For DC Current Applications	250 (121)	SPDT	DKB	DKK	DC9	DKQ	DKS	DA9
		DPDT	DNB	DNK	DF9	DNQ	DNS	DB9
Series F Hermetically Sealed Snap Switch	500 (260)	SPDT	FKB	FKK	FC9	FKQ	FKS	FA9
		DPDT	FNB	FNK	FF9	FNQ	FNS	FB9
Series HS Hermetically Sealed Snap Switch w/Wiring Leads	500 ⑨ (260)	SPDT	HMJ	HMK	—	HMC	HEK ⑩	—
		DPDT	HMS	HMT	—	HMF	HET ⑩	—
Series HS Hermetically Sealed Snap Switch w/Terminal Block	500 ⑨ (260)	SPDT	HM3	HM4	HA9	HM3 ⑪	HM4 ⑪	HA9
		DPDT	HM7	HM8	HB9	HM7 ⑪	HM8 ⑪	HB9
Series 8 Hermetically Sealed Snap Switch	500 (260)	SPDT	8KB	8KK	8C9	8KQ	8KS	8A9
		DPDT	8NB	8NK	8F9	8NQ	8NS	8B9

#### PNEUMATIC SWITCH MECHANISM AND ENCLOSURE

Switch Description	Maximum Supply Pressure		Maximum ⑦ Process Temperature		Bleed Orifice Diameter		A10 Codes	A15 Codes
	psig	bar	°F	°C	Inches	mm	NEMA 1	NEMA 1
Series J Bleed Type Pneumatic Switch	100	7	400	204	.063	1.6	JGF	JDE
	60	4	400	204	.094	2.3	JHF	JEE
Series K Non-Bleed Pneumatic Switch	100	7	400	204	—	—	KOF	KOE

- ① Not available with displacer material and proof-er option codes D, E, F, G, H, J, P, Q, R or T.
- ② Pressure/temperature ratings on page 13. Flanges are ASME type.
- ③ Not available with material of construction codes M and N.
- ④ Not available with material of construction code 4.
- ⑤ 316 SS flange is provided with material of construction code 4 and M.
- ⑥ Consult factory for NEMA 4X/7/9 cast iron housings.
- ⑦ Process temperature based on +100 °F (+38 °C) ambient.
- ⑧ Uncontrolled housing heater or drain available in NEMA 4X/7/9 enclosures. Consult factory for standard part numbers.

- ⑨ On steam applications, temperature down rated to +400 °F (+204 °C) process at +100 °F (+38 °C) ambient. Available with a 6" tall cover only.
- ⑩ CSA approval does not apply to these switch designations.
- ⑪ Available with a 6" tall cover only.
- ⑫ ASME B16.5 150# FF flanges are compatible with ASME B16.1 125# flanges.
- ⑬ Use on model A15 only. Minimum SG = 0.40@ +100 °F (+38 °C).
- ⑭ Model A15 only.



## 4.5 Model Numbers

### 4.5.2 B10 & B15 Dual Switch Models

Note: Each B10 instrument is factory calibrated to operate on a given specific gravity within the minimum and maximum values listed.

#### PART NUMBER CODE AND SPECIFIC GRAVITY LIMITS\*

Part Number Code	Function	Liquid Temp.		Displacer Type		
		°F	°C	Porcelain	Stainless Steel	Karbate
B10†	Wide Differential, Dual Stage	100	38	0.60 to 1.20	0.50 to 1.00	0.50 to 1.00
		200	93	0.64 to 1.50	0.50 to 1.00	0.50 to 1.00
		300	149	0.80 to 1.50	0.60 to 1.00	0.60 to 1.00
		400	204	1.00 to 1.50	0.72 to 1.00	—
		500	260	1.10 to 1.50	0.84 to 1.00	—
B15	Narrow Differential, Dual Stage	100	38	0.95 to 1.20	0.70 to 1.20	0.70 to 1.20
		200	93	1.10 to 1.20	0.80 to 1.20	0.80 to 1.20
		300	149	—	0.90 to 1.20	0.90 to 1.20
		400	204	—	1.00 to 1.20	—
		500	260	—	1.04 to 1.20	—

† When ordering B10 units, an operating sequence and operating specific gravity must be provided.

#### MATERIALS OF CONSTRUCTION

Code	Support Spring	Trim	E-Tube Mtg. Nut	Displacer Clamps/ Susp. Cable	Magnetic Sleeve	Process Connection
1	Inconel 600	300 Series SS	Carbon Steel	316 SS	400 Series SS	Carbon Steel
2	Inconel 600	316 SS	316 SS	316 SS	316 SS	Carbon Steel
4						316 SS
5	Inconel 600	300 Series SS	Carbon Steel	Monel	400 Series SS	Carbon Steel
6				Hastelloy		
M ① NACE Const.	Inconel X750	316 SS	316 SS	316 SS	316 SS	316 SS
N ① NACE Const.	Inconel X750	300 Series SS	316 SS	316 SS	316 SS	Carbon Steel

#### TANK CONSTRUCTION

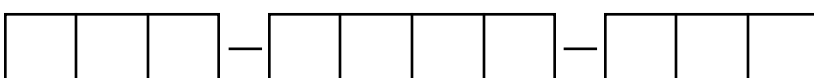
Tank Connection	Code
2½" NPT Threaded ②	E2
3" 150 lb. Flat Face Flange ③④⑩	G2
3" 150 lb. Raised Face Flange ⑤	G3
4" 150 lb. Flat Face Flange ③⑤⑩	H2
4" 150 lb. Raised Face Flange ⑤	H3
4" 300 lb. Raised Face Flange ⑤	H4
6" 150 lb. Flat Face Flange ③④⑩	K2
6" 150 lb. Raised Face Flange ⑤	K3
6" 300 lb. Raised Face Flange ⑤	K4

#### DISPLACER MATERIAL AND PROOF-ER OPTION

Proof-er** Type	Displacer Material			Floating Roof Weight Mat'l Model B15 Only
	Porcelain	316 SS	Karbate	Brass
Without Proof-er	A	B	C	P ③
Low Pressure ②	D ③	E ③	F ③	Q ③

\* Specific gravity limits do not apply to floating roof top units not to be used in liquid.

\*\* Proof-er option constructed of carbon steel material.



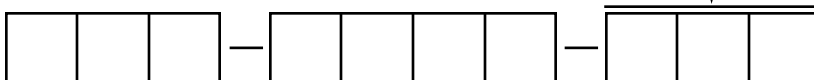
## 4.5 Model Numbers

### 4.5.2 B10 & B15 Dual Switch Models (continued)

#### ELECTRIC SWITCH MECHANISM AND ENCLOSURE <sup>⑦</sup>

Switch Description <sup>⑦</sup>	Max. <sup>⑧</sup> Process Temp. °F (°C)	Two Set Points	Switch Enclosure		
			NEMA 4X/7/9 <sup>⑨</sup>		
			Class I,,Div. 1, Groups C & D	Class I,,Div. 1, Group B	ATEX Ex II,2G EEx d IIC T6
Series B Snap Switch	250 (121)	SPDT	BLB	BLK	BD9
		DPDT	BOB	BOK	BG9
Series C Snap Switch	450 (232)	SPDT	CLB	CLK	CD9
		DPDT	COB	COK	CG9
Series D Snap Switch For DC Current Applications	250 (121)	SPDT	DLB	DLK	DD9
		DPDT	DOB	DOK	DG9
Series F Hermetically Sealed Snap Switch	500 (260)	SPDT	FLB	FLK	FD9
		DPDT	FOB	FOK	FG9
Series 8 Hermetically Sealed Snap Switch	500 (260)	SPDT	8LB	8LK	8D9
		DPDT	8OB	N/A	8G9

- ① Not available with displacer material and proof-er option codes D, E, F, P and Q.
- ② Pressure/temperature ratings on page 13. Flanges are ASME type.
- ③ Not available with material of construction codes M and N.
- ④ Not available with material of construction code 4.
- ⑤ 316 SS flange is provided with material of construction code 4 and M.
- ⑥ Consult factory for NEMA 4X/7/9 cast iron housings.
- ⑦ Pneumatic switch mechanisms and enclosures are unavailable for Models B10 and B15 switches.
- ⑧ Process temperature based on +100 °F (+38 °C) ambient.
- ⑨ Uncontrolled housing heater or drain available in NEMA 4X/7/9 enclosures. Consult factory for standard part numbers.
- ⑩ ASME B16.5 150# FF flanges are compatible with ASME B16.1 125# flanges.



## 4.5 Model Numbers

### 4.5.3 C10 & C15 Triple Switch Models

Note: Each C10 and C15 instrument is factory calibrated to operate for a given specific gravity within the minimum and maximum values listed.

#### PART NUMBER CODE AND SPECIFIC GRAVITY LIMITS

Part Number Code	Function	Liquid Temp.		Displacer Type		
		°F	°C	Porcelain	Stainless Steel	Karbate
C10†	Wide Differential, 3 switches	100	38	0.65 to 1.20	0.58 to 1.20	0.58 to 1.20
		200	93	0.95 to 1.10	0.76 to 1.00	0.76 to 1.00
		300	149	—	0.820 to 1.00	0.82 to 1.00
C15††	Narrow Differential, 3 switches	130	54	0.80 to 1.25	0.65 to 1.00	0.65 to 1.00

† When ordering C10 units, an operating sequence and operating specific gravity must be provided.

†† When ordering C15 units, an operating specific gravity must be provided.

#### MATERIALS OF CONSTRUCTION

Code	Support Spring	Trim	E-Tube Mtg. Nut	Displacer Clamps/Susp. Cable	Magnetic Sleeve	Process Connection
1	Inconel 600	300 Series SS	Carbon Steel	316 SS	400 Series SS	Carbon Steel
2	Inconel 600	316 SS	316 SS	316 SS	316 SS	Carbon Steel
4						316 SS
5	Inconel 600	300 Series SS	Carbon Steel	Monel	400 Series SS	Carbon Steel
6				Hastelloy		
M NACE Const.	Inconel X750	316 SS	316 SS	316 SS	316 SS	316 SS
N NACE Const.	Inconel X750	300 Series SS	316 SS	316 SS	316 SS	Carbon Steel

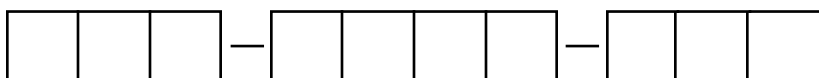
#### TANK CONNECTION AND DISPLACERS

Tank Connection ①	Displacer Material		
	Porcelain	316 SS	Karbate
2½" NPT Threaded	E2A	E2B	E2C
3" 150 lb. Flat Face Flange ②⑥	G2A	G2B	G2C
3" 150 lb. Raised Face Flange ③	G3A	G3B	G3C
4" 150 lb. Flat Face Flange ②⑥	H2A	H2B	H2C
4" 150 lb. Raised Face Flange ③	H3A	H3B	H3C
4" 300 lb. Raised Face Flange ⑧	H4A	H4B	H4C
6" 150 lb. Flat Face Flange ②⑥	K2A	K2B	K2C
6" 150 lb. Raised Face Flange ③	K3A	K3B	K3C
6" 300 lb. Raised Face Flange ③	K4A	K4B	K4C

#### ELECTRIC SWITCH MECHANISM AND ENCLOSURE ④

Switch Description	Process ⑤ Temp. Range °F (°C)	Three Set Points	Switch Enclosure	
			TYPE 4X/7/9 Aluminum Enclosure ⑦	
			Class I,,Div. 1, Groups C & D	Class I,,Div. 1, Group B
Series O Snap Switch	-40 to +300 (-40 to +149)	SPDT	OMB	OMN
		DPDT	OKB	OKN
Series Q Snap Switch	-40 to +250 (-40 to +121)	SPDT	QMB	QMN
		DPDT	QKB	QKN

- ① Pressure/temperature ratings on page 13. Flanges are ASME type.
- ② Not available with material of construction codes M, N and 4.
- ③ 316 SS flange is provided with material of construction code 4 and M.
- ④ Pneumatic switch mechanisms and enclosures are unavailable for Series C10 and C15 switches.
- ⑤ Process temperature based on +100 °F (+38 °C) ambient.
- ⑥ ASME B16.5 150# FF flanges are compatible with ASME B16.1 125# flanges.
- ⑦ Consult factory for TYPE 4X/7/9 cast iron housings.
- ⑧ Available only in carbon steel. Consult factory for 4" 300 lb. 316 SS flanged connection.



---

**NOTES**

### Service Policy

Owners of Magnetrol controls may request the return of a control or any part of a control for complete rebuilding or replacement. They will be rebuilt or replaced promptly. Controls returned under our service policy must be returned by Prepaid transportation. Magnetrol will repair or replace the control at no cost to the purchaser (or owner) other than transportation if:

1. Returned within the warranty period; and
2. The factory inspection finds the cause of the claim to be covered under the warranty.

If the trouble is the result of conditions beyond our control; or, is NOT covered by the warranty, there will be charges for labor and the parts required to rebuild or replace the equipment.

In some cases it may be expedient to ship replacement parts; or, in extreme cases a complete new control, to replace the original equipment before it is returned. If this is desired, notify the factory of both the model and serial numbers of the control to be replaced. In such cases, credit for the materials returned will be determined on the basis of the applicability of our warranty.

No claims for misapplication, labor, direct or consequential damage will be allowed.

### Return Material Procedure

So that we may efficiently process any materials that are returned, it is essential that a "Return Material Authorization" (RMA) number be obtained from the factory, prior to the material's return. This is available through Magnetrol's local representative or by contacting the factory. Please supply the following information:

1. Company Name
2. Description of Material
3. Serial Number
4. Reason for Return
5. Application

Any unit that was used in a process must be properly cleaned in accordance with OSHA standards, before it is returned to the factory.

A Material Safety Data Sheet (MSDS) must accompany material that was used in any media.

All shipments returned to the factory must be by prepaid transportation.

All replacements will be shipped F.O.B. factory.



705 Enterprise Street • Aurora, Illinois 60504-8149 • 630-969-4000  
info@magnetrol.com • www.magnetrol.com

Copyright © 2018 Magnetrol International, Incorporated

Monel® and Inconel® are registered trademarks of Special Metals Corporation (Formerly Inco Alloys International)  
Hastelloy® is a registered trademark of Haynes International, Inc.  
Karbate® is a registered trademark of National Carbon Company, Inc.

**BULLETIN: 45-610.28**  
**EFFECTIVE: February 2018**  
**SUPERSEDES: September 2017**