

Replacement and Calibration of Rosemount 2130 Electronics Cassettes



**NOTICE**

Refer to the Rosemount 2130 Reference Manual (Document Number 00809-0100-4130) for more instructions. Manuals are available electronically on www.rosemount.com.

**WARNING****Failure to follow these installation guidelines could result in death or serious injury**

- The Rosemount 2130 is a *liquid level switch*. It must be installed, connected, commissioned, operated, and maintained by suitably qualified personnel only, observing any national and local requirements that may apply
- Ensure the wiring is suitable for the electrical current and the insulation is suitable for the voltage, temperature, and environment
- Use the equipment only as specified. Failure to do so may impair the protection provided by the equipment
- Any substitution of non-recognized parts may jeopardize safety and is under no circumstances allowed

Explosions could result in death or serious injury

- Installation of the 2130 in a hazardous environment must be in accordance with the appropriate local, national, and international standards, codes, and practices. Please review the Product Certifications section for any restrictions associated with a safe installation
- Verify that the operating atmosphere of the 2130 is consistent with the appropriate hazardous locations certifications

External surface may be hot

- Care must be taken to avoid possible burns

Process leaks could result in death or serious injury

- Install and tighten process connectors before applying pressure
- Do not attempt to loosen or remove process connectors while the 2130 is in service

Electrical shock could cause death or serious injury

- If the liquid level switch is installed in a high voltage environment and a fault condition or installation error occurs, high voltage may be present on leads and terminals
- Use extreme caution when making contact with the leads and terminals
- Make sure that power to the 2130 is off while making connections

Replacement and calibration of electronic cassettes

When replacing a damaged or faulty cassette, it is necessary to calibrate the replacement cassette to the operating frequency of the fork assembly.

Replacement sequence

If this replacement is taking place in a hazardous area, only qualified personnel should perform the replacement. All work in hazardous areas must be carried out in accordance to national and local codes of practice. Refer to the Rosemount 2130 manual (00809-0100-4130) for product certifications and safety instructions for specific hazardous area installations.

Calibration of this device is complex and it may take several attempts before calibration is successful.

On Intrinsically Safe (I.S.) approved versions of the 2130, it is recommended that replacement and calibration be performed in a non-hazardous (safe) area.

Note

- In I.S. applications, NAMUR cassettes can only be replaced with NAMUR cassettes, and 8/16 mA cassettes can only be replaced by 8/16 mA cassettes
- Non-I.S. cassettes can be interchanged with other non-I.S. cassettes, but the new label must be fitted and the original part number transferred to the new label (see “[Electrical installation](#)” on page 6 for connections to the electronic cassettes)
- Before starting the replacement and calibration procedure, ensure that any controlled process will not be adversely affected

To replace the cassette, do the following:

1. Isolate and disconnect the power to the 2130, and insulate the ends of the wires. On a 2130 with a relay cassette, there may be more than one power source.
2. Remove the cover and disconnect the wires, noting any connections ([Figure 1](#)), the LED color (operating mode), and the exact mode switch position ([Figure 2](#)) on the cassette to be replaced.
3. Remove and retain the two fixing screws from the base of the cassette and unplug the cassette.
4. Plug in the replacement cassette, refit the screws, reconnect the wires, and set the mode switch to “Wet On” with a one second delay ([Figure 3](#)).
5. Reconnect the power to the 2130.
6. Proceed to “[Calibration sequence](#)” on page 5.

Figure 1. Top-down view of example cassette inside the housing

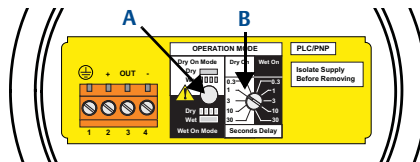

A. LED

B. Mode Switch and Time Delay

Figure 2. Mode switch and setting on the existing cassette

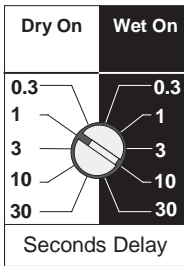

This is an example of how the existing cassette may look. Here, the switch is set to “Dry On” with a one second delay. Take note of the actual setting.

SETTING IS: _____

Figure 3. Mode switch setting on the replacement cassette

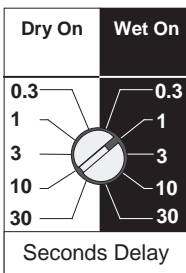

Set the mode switch of the new cassette to “Wet On” with a one second delay.

Figure 4. Magnetic test point

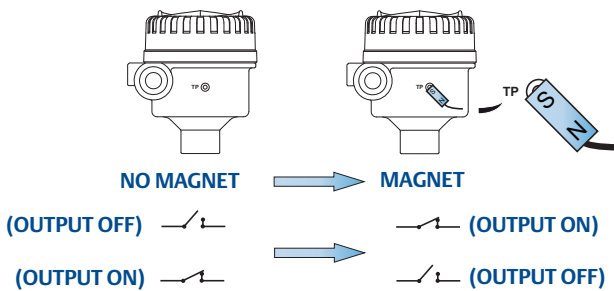



Calibration sequence

This section describes what is required for calibration. Calibration sequence steps 3 to 13 are *time dependent* and must be carried out within the noted times. The purpose of the time dependency and switching sequence is to prevent an accidental calibration from occurring.

To calibrate the cassette, do the following:

1. Ensure that the forks are dry, and the mode switch is set to “Wet On” with a one second time delay ([Figure 3](#)).
2. Check that the LED is flashing at a rate of one flash per second.
If it is on continuously, proceed to step 8.
3. Apply magnet to the test-point (as shown on [page 4](#)).
4. After a one second delay, the LED will be lit continuously.
5. Within three seconds rotate the mode switch two steps clockwise.
6. After a two second delay, the LED will go out.
7. Within three seconds, rotate the mode switch two steps counter-clockwise.
Proceed to step 13.
8. Apply magnet to test point (as shown on [page 4](#)).
9. After a one second delay, the LED will flash at a rate of one flash per second.
10. Within three seconds, rotate the mode switch two steps clockwise.
11. After a two second delay, the LED will go out (stop flashing).
12. Within three seconds, rotate the mode switch two steps counter-clockwise.
13. After a two second delay, the LED should flash twice per second.
14. If the LED is flashing twice per second, the calibration has occurred correctly. Remove the magnet from the test-point. After a one second delay, the unit will return to normal operation. Proceed to step 17.
15. If the LED is flashing once per second or it is on continuously, the calibration has failed. Remove the magnet from the test-point, wait ten seconds, and then repeat from step 2.
16. If the LED stays off after the two second delay of step 13, the sensor is not working correctly. Check that the sensor forks are clean and dry. Also, verify there is nothing jamming or touching the sensor. If no fault is found with the sensor, the entire unit should be returned for repair.
17. Set the mode switch to the original setting noted in [Figure 2](#) and wait five seconds.
18. Set the operating mode to self-check (yellow LED) or normal mode (red LED), as applicable to your installation.
Instructions are in “[Setting the operating mode](#)” on [page 12](#).
19. Replace the cover and check that the system works.

Electrical installation

-  Before use, check that suitable cable glands and blanking plugs are fitted and fully tightened.
-  Isolate supply before connecting the switch or removing the electronics.
-  The Protective Earth (PE) terminal must be connected to an external earthing system.

Direct load switching electronics cassette (two-wire, red label)

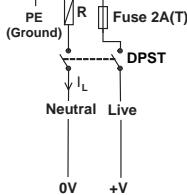
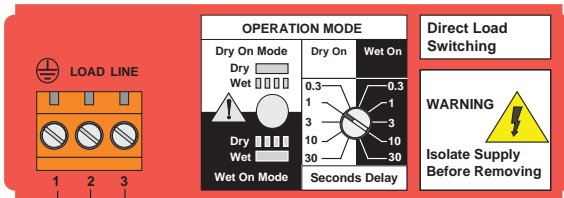

R = External load (must be fitted)

U = 20 - 264 V ~ (ac) (50/60Hz)

I_{OFF} < 4 mA at 20 °C (24 - 230 Vac)

I_{OFF} < 6 mA at -40 to 80 °C (20 - 264 Vac)

I_L = 20 - 500 mA

I_{PK} = 5 A, 40 ms (inrush)



U = 20 - 60 V --- (dc)

I_{OFF} < 4 mA

I_L = 20 - 500 mA

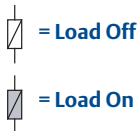
I_{PK} = 5 A, 40 ms (inrush)

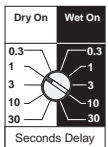
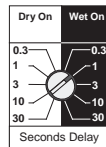
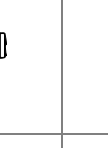

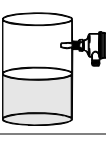
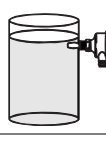
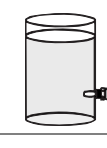
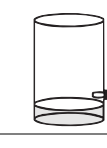
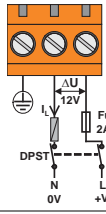
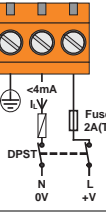
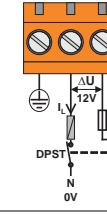
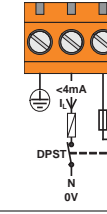
High level Dry = ON		Low level Wet = ON	
			
			
			
LED on continuously	LED flashes each second	LED on continuously	LED flashes each second

PNP/PLC electronics cassette (three-wire, yellow label)

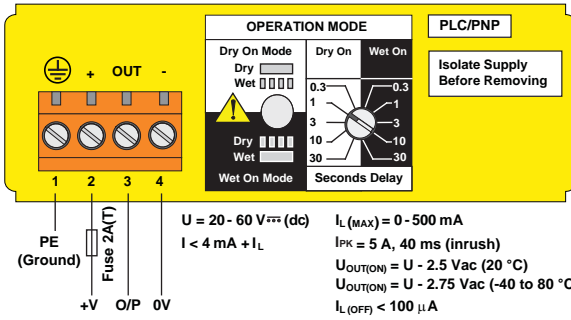

	High level Dry = ON		Low level Wet = ON	
PLC (positive input)				
	LED on continuously	LED flashes each second	LED on continuously	LED flashes each second

DPCO Relay cassette (Dark green label)

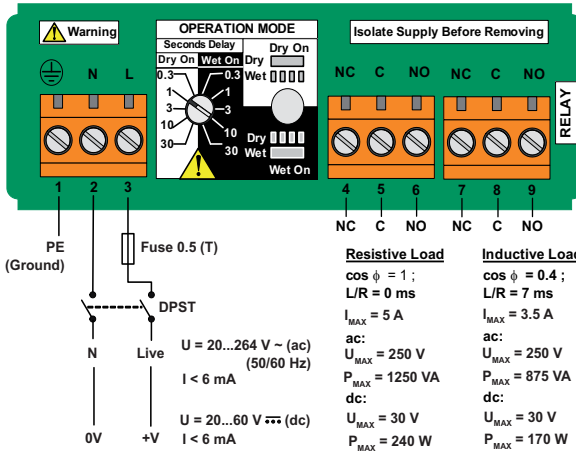

High level Dry = ON		Low level Wet = ON	
LED on continuously	LED flashes each second	LED on continuously	LED flashes each second

Fault and Alarm Relays (2 x SPCO) electronics cassette (light green label)

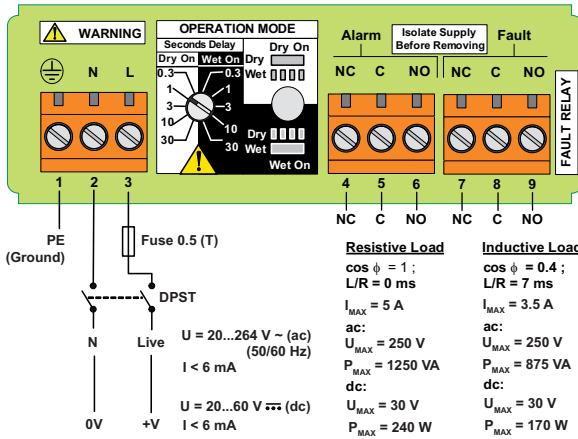

High level Dry = ON		Low level Wet = ON	
(No alarm) (No fault)	(Alarm) (No fault)	(No alarm) (No fault)	(Alarm) (No fault)
LED on continuously	LED flashes each second	LED on continuously	LED flashes each second

NAMUR electronics cassette (light blue label)

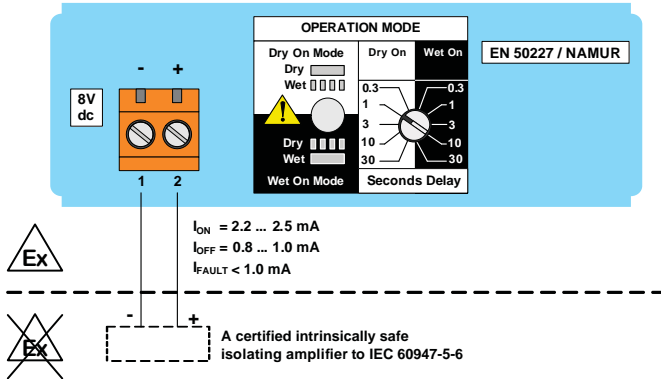

High level Dry = ON		Low level Wet = ON	
LED on continuously	LED flashes each second	LED on continuously	LED flashes each second

Note

- This cassette is suitable for Intrinsically Safe applications and requires a certified isolating barrier. See the Rosemount 2130 Reference Manual (00809-0100-4130) for Intrinsically Safe approvals
- This electronics cassette is also suitable for non-hazardous (safe) area applications. It can only be interchanged with the 8/16 mA cassette.
- Do not exceed 8 Vdc

8/16 mA electronics cassette (dark blue label)

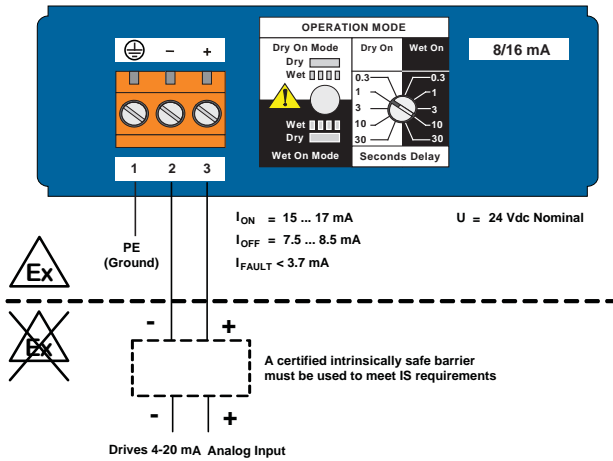

High level Dry = ON		Low level Wet = ON	
LED on continuously	LED flashes each second	LED on continuously	LED flashes each second

Note

- This cassette is suitable for Intrinsically Safe applications and requires a certified isolating barrier. See the Rosemount 2130 Reference Manual (00809-0100-4130) for Intrinsically Safe approvals
- This cassette is also suitable for non-hazardous (safe) area applications. It can only be interchanged with a NAMUR cassette

Setting the operating mode

Selecting the self-check operating mode

When the self-check mode is operating, the 'heartbeat' LED color is yellow.

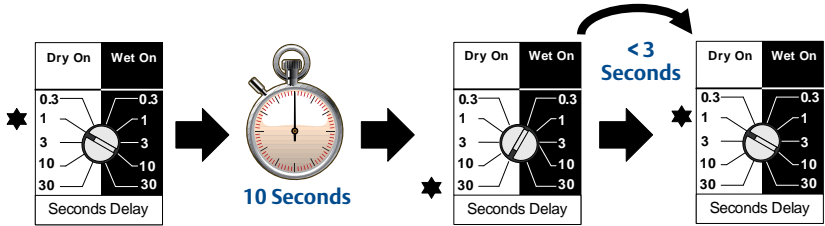

Selecting the normal operating mode

When the normal mode is operating, the 'heartbeat' LED color is red.

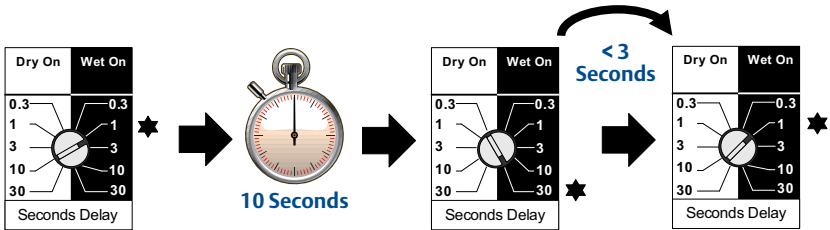

Troubleshooting

If there is a malfunction, see [Table 1](#) for information on possible causes.

Table 1. Troubleshooting chart

Fault	Symptom/Indication	Action/Solution
Does not switch	No LED; no power	Check the power supply; (check load on direct load switching electronics model)
	LED flashing	See "LED indication" on page 14
	Fork is damaged	Replace the 2130
	Thick encrustation on the fork	Clean the fork with care
	5 second delay when changing mode/delay	This is normal – wait 5 seconds
Incorrect switching	Dry = On, Wet = On set incorrectly	Set the correct mode on the electronics cassette
Faulty switching	Turbulence	Set a longer switching time delay
	Excessive electrical noise	Suppress the cause of the interference
	Cassette has been fitted from another Rosemount 2130	Fit the factory supplied cassette (page 3) and then calibrate (page 5)









LED indication

Table 2. LED colors

LED Colors	Operating Modes ¹	Description of Mode
Red	Normal	When the LED is red and flashing, it indicates the 2130 may be uncalibrated, successfully calibrated, has an electrical load problem, or has an internal PCB fault. See Table 3 for further information.
Yellow	Self-Check	When the LED is yellow and flashing, it indicates the same as Normal mode and that there could be external damage to forks, corroded forks, or internal sensor damage. See Table 3 for further information.

1. See "Setting the operating mode" on page 12.

Table 3. LED flash rate







LED Flash Rate	Switch Status
 Continuous	Output state is on
 1 every second	Output state is off
 1 every $\frac{1}{2}$ second and every third flash is missing	External damage to forks; corroded forks; internal wire damage; internal sensor damage ¹ (<i>Self-Check mode only</i>)
 1 every 2 seconds	Uncalibrated ²
 1 every 4 seconds	Load fault; load current too high; load short circuit
 2 times every second	Indication of successful calibration
 3 times every second	Internal PCB fault (microprocessor, ROM, or RAM)
 Off	Problem (e.g. supply)

1. See "Fault condition detected (self-check mode only)" on page 15.

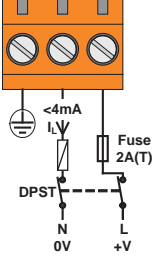
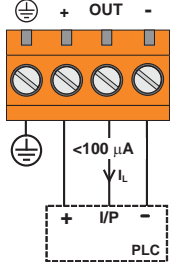
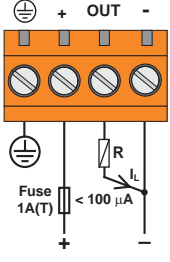
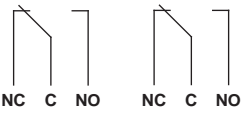
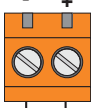
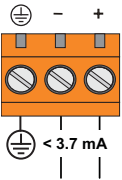
2. See "Calibration sequence" on page 5.

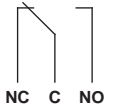
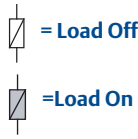
Fault condition detected (self-check mode only)

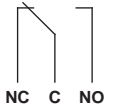
When a fault condition is detected in the self-check operating mode, the ‘heartbeat’ LED flashes once every half a second and every third flash is missed. The output from the Rosemount 2130 will then be as follows:

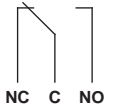
Direct Load	PLC	PNP dc		
 <p style="text-align: center;">(=Fault)</p>	 <p style="text-align: center;">(=Fault)</p>	 <p style="text-align: center;">(=Fault)</p>		
<p style="text-align: center;">DPCO Relay</p>  <p style="text-align: center;">(=Fault)</p>	<p style="text-align: center;">NAMUR</p>  <p style="text-align: center;">(=Fault)</p>	<p style="text-align: center;">8/16 mA</p>  <p style="text-align: center;">(=Fault)</p>		
Fault and Alarm (2 x SPCO) Relays				
<table style="width: 100%; border: none;"> <tr> <td style="text-align: center; width: 50%; border: none;"> <p>Alarm Relay</p>  <p style="text-align: center;">(=No alarm)</p> </td> <td style="text-align: center; width: 50%; border: none;"> <p>Fault Relay</p>  <p style="text-align: center;">(=Fault)</p> </td> </tr> </table> <div style="text-align: right; margin-top: 20px;">  <p>= Load Off</p> <p>= Load On</p> </div>			<p>Alarm Relay</p>  <p style="text-align: center;">(=No alarm)</p>	<p>Fault Relay</p>  <p style="text-align: center;">(=Fault)</p>
<p>Alarm Relay</p>  <p style="text-align: center;">(=No alarm)</p>	<p>Fault Relay</p>  <p style="text-align: center;">(=Fault)</p>			

Note

See “LED indication” on page 14 for causes of other LED flashing rates.

Rosemount Inc.
8200 Market Boulevard
Chanhassen, MN 55317, USA
T (US) (800) 999-9307
T (Intnl) (952) 906-8888
F (952) 906-8889

**Emerson Process Management
Latin America**
1300 Concord Terrace, Suite 400
Sunrise Florida 33323 USA
T + 1 954 846 5030

**Emerson Process Management
Asia Pacific Private Limited**
1 Pandan Crescent
Singapore 128461
T (65) 6777 8211
F (65) 6777 0947/65 6777 0743

**Emerson Process Management
GmbH & Co. OHG**
Argelsrieder Feld 3
82234 Wessling Germany
T 49 (8153) 9390, F49 (8153) 939172

**Beijing Rosemount Far East
Instrument Co., Limited**
No. 6 North Street, Hepingli,
Dong Cheng District
Beijing 100013, China
T (86) (10) 6428 2233
F (86) (10) 6422 8586

© 2013 Rosemount Inc. All rights reserved. All marks property of owner.
The Emerson logo is a trade mark and service mark of Emerson Electric Co
Rosemount and the Rosemount logotype are registered trademarks of Rosemount Inc.