

Tuffy® II Liquid Level Controls with Electric Switches

Installation and Operating Manual

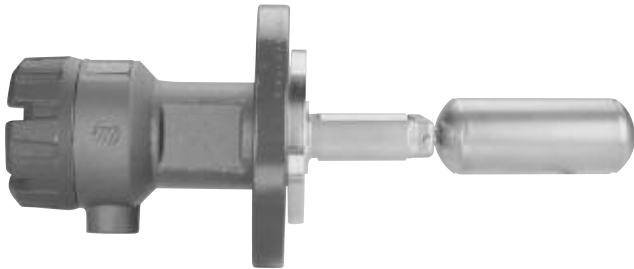

*Side
Mounted
Float Level
Switch*

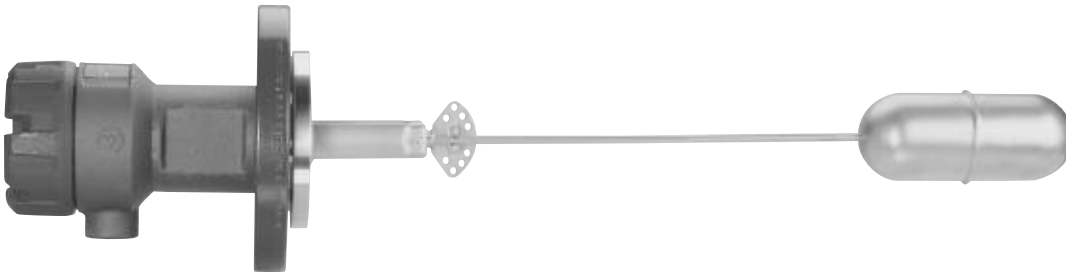
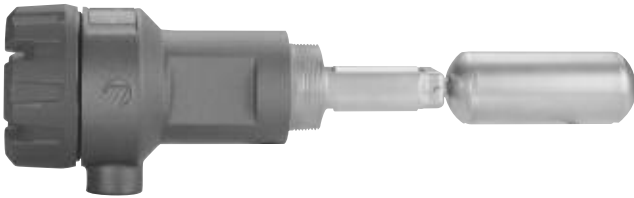

Read this Manual Before Installing

This manual provides information on the Tuffly® II Float Level Switch. It is important that all instructions are read carefully and followed in sequence. Detailed installation and wiring instructions are included in this manual.

Conventions Used in this Manual

Certain conventions are used in this manual to convey specific types of information. General technical material, support data, and safety information are presented in narrative form. The following styles are used for notes, cautions, and warnings.

Notes

Notes contain information that augments or clarifies an operating step. Notes do not normally contain actions. They follow the procedural steps to which they refer.

Cautions

Cautions alert the technician to special conditions that could injure personnel, damage equipment, or reduce a component's mechanical integrity. Cautions are also used to alert the technician to unsafe practices or the need for special protective equipment or specific materials. In this manual, a caution box indicates a potentially hazardous situation which, if not avoided, may result in minor or moderate injury.

Warnings

Warnings identify potentially dangerous situations or serious hazards. In this manual, a warning indicates an imminently hazardous situation which, if not avoided, could result in serious injury or death.

Safety Messages

Follow all standard industry procedures for servicing electrical equipment when working with or around high voltage. Always shut off the power supply before touching any components.

WARNING! Explosion hazard. Do not connect or disconnect equipment unless power has been switched off or the area is known to be non-hazardous.

Low Voltage Directive

For use in Installations Category II, Pollution Degree 2. If equipment is used in a manner not specified by the manufacturer, protection provided by equipment may be impaired.

Notice of Trademark, Copyright, and Limitations

Magnetrol® & Magnetrol® logotype, and Tuffly® are registered trademarks of Magnetrol® International, Incorporated.

Copyright © 2016 Magnetrol® International, Incorporated. All rights reserved.

Performance specifications are effective with date of issue and are subject to change without notice. Magnetrol® reserves the right to make changes to the product described in this manual at any time without notice. MAGNETROL makes no warranty with respect to the accuracy of the information in this manual.

Warranty

All MAGNETROL mechanical level and flow controls are warranted free of defects in materials or workmanship for five full years from the date of original factory shipment.

If returned within the warranty period; and, upon factory inspection of the control, the cause of the claim is determined to be covered under the warranty; then, MAGNETROL will repair or replace the control at no cost to the purchaser (or owner) other than transportation.

MAGNETROL shall not be liable for misapplication, labor claims, direct or consequential damage or expense arising from the installation or use of equipment. There are no other warranties expressed or implied, except special written warranties covering some MAGNETROL products.

Quality Assurance

The quality assurance system in place at MAGNETROL guarantees the highest level of quality throughout the company. MAGNETROL is committed to providing full customer satisfaction both in quality products and quality service.

The MAGNETROL quality assurance system is registered to ISO 9001 affirming its commitment to known international quality standards providing the strongest assurance of product/service quality available.





Tuffly® II Liquid Level Controls with Electric Switches

Table of Contents

1.0 Installation		
1.1 Unpacking	4	
1.2 Before You Begin	4	
1.2.1 Site Preparation	4	
1.2.2 Equipment and Tools.....	4	
1.3 Mounting	5	
1.3.1 Mounting an NPT Tuffly® II.....	5	
1.3.2 Mounting a Flanged Tuffly® II.....	5	
1.3.3 Mounting External Cage Tuffly® II.....	5	
1.4 Wiring.....	7	
1.5 Adjustable Differential.....	8	
1.6 Interface	9	
2.0 Reference Information		
2.1 Description	9	
2.2 Theory of Operation.....	10	
2.3 Troubleshooting.....	10	
2.3.1 External Causes	10	
2.3.2 Tuffly® II Causes.....	10	
2.4 Preventive Maintenance.....	12	
2.4.1 What to Do	12	
2.4.2 What to Avoid.....	13	
2.4.3 Switch Mechanism Replacement.....	13	
2.5 Agency Approvals	14	
2.6 Parts	14	
2.6.1 Replacement Parts	14	
2.6.2 Recommended Spare Parts.....	14	
2.7 Specifications.....	15	
2.7.1 Functional	15	
2.7.2 Performance.....	15	
2.7.3 Switch Temperature Ratings	16	
2.7.4 Physical.....	19	
2.8 Model Numbers	21	
2.8.1 Standard Narrow Differential Models.....	22	
2.8.2 Chamber Model Number	23	
2.8.3 Interface Models.....	24	
2.8.4 Adjustable Wide Differential Models.....	26	

1.0 Installation

This section provides detailed procedures for properly installing the Tuffly® II Liquid Level Switch.

Caution: If equipment is used in a manner not specified by manufacturer, protection provided by equipment may be impaired.

1.1 Unpacking

Unpack the instrument carefully. Inspect all units for damage. Report any concealed damage to the carrier within 24 hours. Ensure all components have been removed from the packing material. Check all the contents against the packing slip and report any discrepancies to the factory. Check the nameplate model number to ensure that it agrees with the packing slip and purchase order. Record the serial and model numbers for future reference when ordering parts.

Model Number

Serial Number

1.2 Before You Begin

1.2.1 Site Preparation

1. Ensure that the length and inside diameter of the mounting nozzle are sized correctly for the TUFFY II model and the required actuation levels. Maximum nozzle lengths for each model are specified in **Figure 1**.
2. Ensure that the mounting nozzle or coupling is within 3° of horizontal. If mounting the TUFFY in an external cage, ensure that the cage is mounted within 3° of horizontal and that the top/bottom piping is within 3° of vertical in all directions.
3. Ensure that the area is free of metallic particles which might be attracted to the magnet holder/counterbalance and interfere with the function of the TUFFY II.

1.2.2 Equipment and Tools

No special equipment or tools are required to install the TUFFY Liquid Level Switch. The following items are recommended:

- Wrenches, flange gaskets and flange bolting appropriate for process connection(s).
- Pipe wrench
- Level
- Flat head screwdriver

Tuffly® II Maximum Nozzle Lengths (distance from face of mounting flange to end of 3" sch 80 nozzle or the tip of the mounting threads to the end of 2" nozzle with ID same as 2" NPT)	
T31 or T35 with NPT connection	3.29"
T31, T32, T33, T34 or T35 with flanged connection	3.35"
T3B	5.80"
T3C	4.35"

Figure 1
Maximum nozzle length

1.3 Mounting

The TUFFY II Liquid Level Switch is available with a 2" NPT mounting bushing, a variety of flange mountings and external cages for mounting outside of the vessel.

Caution: This instrument is intended for use in Installation Category II, Pollution Degree 2.

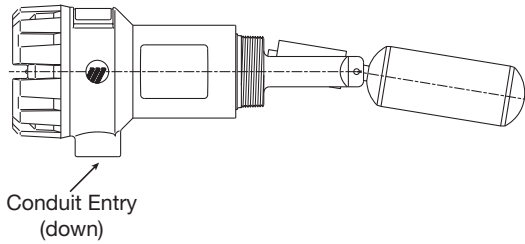

Figure 2
NPT Mounting Orientation

1.3.1 Mounting an NPT Tuffly® II

1. Apply either Teflon® tape or appropriate lubricant to the mounting threads to prevent galling.
2. Engage the 2" NPT by hand to avoid damaging threads.
3. Using a pipe wrench, rotate the unit clockwise until threads are tight in mounting. Ensure that the conduit entry points down. **See Figure 2.**

Caution: The TUFFY II must be installed with the conduit connection pointing downward to ensure correct switching action.

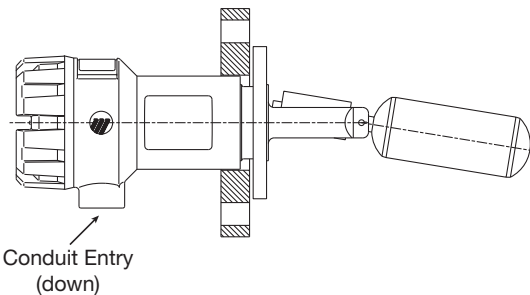

Figure 3
Flanged Mounting Orientation

1.3.2 Mounting a Flanged Tuffly® II

1. Have proper flange bolting and gasket on hand.
2. Cut and remove plastic shipping straps.
3. Carefully align TUFFY flange raised face (cladding) with the face of the vessel mounting flange. Slide the flange on the control to the vessel mounting flange and align bolt holes. Ensure that the conduit entry is pointing down. **See Figure 3.**
4. Ensure that the flange gasket is seated properly. Install flange bolts and nuts.
5. Tighten alternating flange bolts in a star pattern.

Caution: The TUFFY II must be installed with the conduit connection pointing downward to ensure correct switching action.

1.3.3 Mounting External Cage Tuffly® II

A typical TUFFY external cage installation is shown in **Figure 4**.

1. Install cage so that trappings are within 3° of vertical in all directions. Check installation with a level.
2. Mount cage as close to vessel as possible to provide more accurate level in cage. Long pipe runs may result in cooler, denser liquid than that in the vessel and cause inaccurate level in the TUFFY cage.

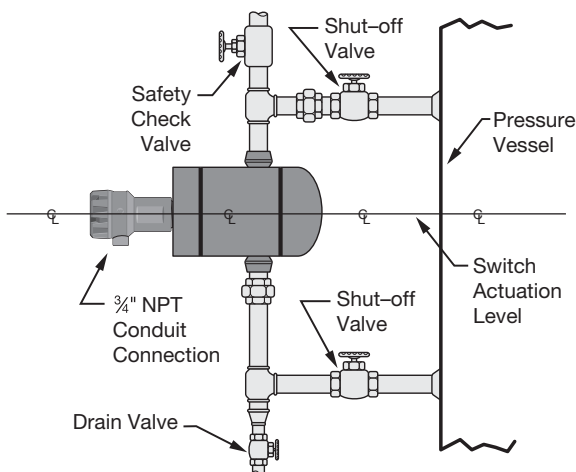

Figure 4
External Cage Mounting

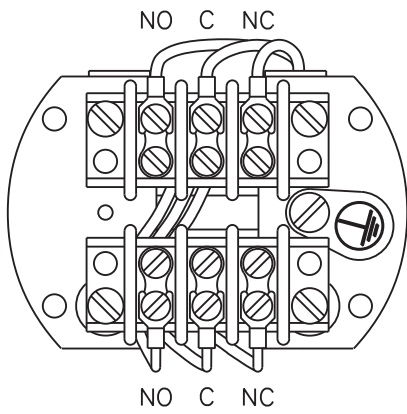

Figure 5
Terminal Connections
DPDT Dry Contact switch
with silver contacts

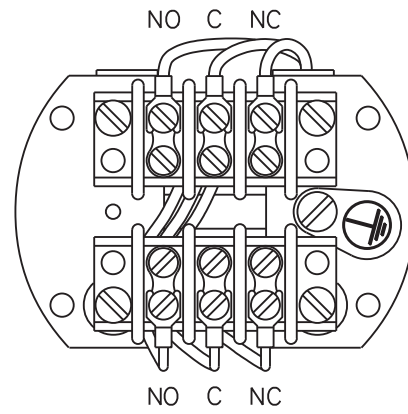

Figure 6
Terminal Connections
DPDT Dry Contact switch
with gold contacts

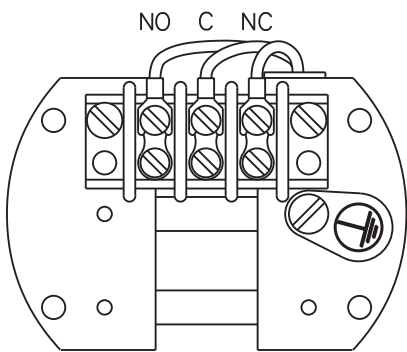

Figure 7
Terminal Connections
SPDT Dry Contact switch
with silver or gold contacts

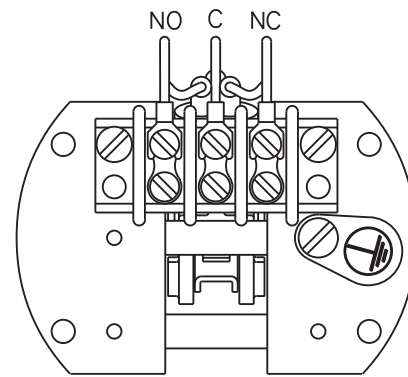

Figure 8
Terminal Connections SPDT HS switch
with silver or gold contacts

-
3. Use pipe of sufficient size and strength to support the control. Provide a hanger or stand to help support the weight of the cage if necessary.
 4. All piping should be straight and free of low spots or pockets. Lower liquid line should drain toward vessel and upper line toward control.
 5. Shut-off valves are recommended for installation between the vessel and the cage assembly.
 6. Once external cage is mounted, install TUFFY II into cage per *Section 1.3.1* or *Section 1.3.2* on page 5.

Caution: Operation of all buoyancy type level devices should be done in such a way as to minimize the action of dynamic forces on the float or displacer sensing element. Good practice for reducing the likelihood of damage to the control is to equalize pressure across the device very slowly.

1.4 Wiring

NOTE: A switch or circuit breaker shall be installed in close proximity to equipment and within easy reach of operator. It shall be marked as the disconnecting device for the equipment.

NOTE: For supply connections in installations with ambient temperature up to +158° F (+70° C), use wire with a minimum rating of +167° F (+75° C), as required by process conditions. Installations with ambient temperatures up to +176° F (+80° C) require wire with a minimum rating of +185° F (+85° C) as required by the process conditions. Use a minimum of 14 AWG wire for power and ground field wires.

On high temperature applications above +250° F (+120° C) process temperature, a suitable heat resistant covered wire should be used between the TUFFY II and the first junction box located in a cooler area. On non-hazardous applications, flexible conduit may be used between TUFFY II and the first junction box. Conduit should have sufficient slack to permit removal of the switch assembly.

1. Unscrew and remove switch cover.
2. Pull in supply wires and connect to the proper terminals, **Figure 5, 6, 7 & 8**. Please note that some switches are reverse acting. Be sure to connect to proper terminals according to wiring diagrams.

NOTE: Ensure that excess wire does not interfere with replacement of the switch cover or movement of the switch mechanism.

NOTE: The ground screw (green head) is located to the right of the switch. Housing must be grounded via protective ground screw in base of housing. Hazardous locations require a conduit seal within 18" (457 mm) of the conduit connection, and the conduit must be screwed into the housing a minimum of 5 times.

NOTE: For ATEX Flameproof Installations, the cable entry device must be certified in type protection flameproof enclosure “d”, suitable for the conditions of use and currently installed.

For ambient temperatures above +55° C, suitable heat resistant cables must be used.

3. Replace the switch cover.

NOTE: Hand-tighten cover. Then using a persuader, tighten ¼ turn more. This entire process should take approximately 6½ turns.

4. To prevent the entrance of air, seal housing at the conduit outlet with a suitable pipe compound.
5. Connect power supply to TUFFY and test switch action by varying level in vessel.

NOTE: If the switch mechanism fails to function properly, ensure that the conduit connection is vertically aligned and pointing down.

1.5 Adjustable Differential

The Adjustable Differential TUFFY II, model T3C, may be set in the field for one of a variety of level differentials. By specific placement of the stops in the holes of the adjustment plate, the level differential may be changed.

To determine the best placement of the stops for your application, refer to **Figures 9** and **10**. By subtracting the actuating level of the lower hole on the adjusting plate on falling level from the actuating level of the upper hole on the adjusting plate on rising level, the total level differential between the switch actuating and resetting can be calculated.

Example 1: To determine the level differential of a unit with a 7.50" stem and stops positioned in holes L & B, subtract the actuating level of stop position B with a 7.50" stem from the actuating level of stop position L.

$$6.01" - 4.51" = 1.50" \text{ level differential}$$

Example 2: The level differential of a unit with a 12.25" stem and stops positioned in holes C & G is as follows:

$$7.20" - (-8.06") = 15.26"$$

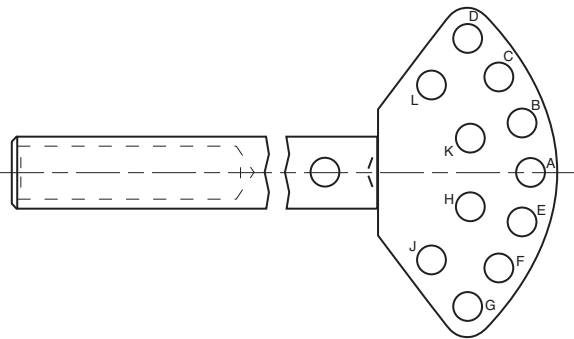

Figure 9
Adjustment Plate Stop Position

	Stem Length	Pin Position											
		A	B	C	D	E	F	G	H	J	K	L	
Rising	3.75	+0.16	+1.84	+3.54	+4.87	-1.47	n/a	n/a	-1.65	n/a	+1.52	+4.10	
	7.50	-0.12	+2.49	+5.14	+7.20	-2.65	n/a	n/a	-2.94	n/a	+1.99	+6.01	
	12.25	-0.43	+3.36	+7.20	+10.20	-4.12	n/a	n/a	-4.54	n/a	+2.62	+8.46	
Falling	3.75	+1.51	+3.14	n/a	n/a	-0.39	-1.87	-3.21	0.16	-2.44	+3.32	n/a	
	7.50	+1.98	+4.51	n/a	n/a	-0.99	-3.29	-5.37	-0.12	-4.16	+4.80	n/a	
	12.25	+2.61	+6.28	n/a	n/a	-1.69	-5.04	-8.06	-0.44	-6.31	+6.71	n/a	

Figure 10
Stop Position Actuation Levels
(Inches (± 0.25) at minimum S.G.)

Once the desired stop positions are determined, remove the cotter pins holding the stops in the adjusting plate holes. Move each stop to the desired location on the adjusting plate and replace the cotter pins. Ensure that the float stem is positioned between the two stops.

When determining stop positions, please note that some stop position combinations are impossible due to the diameter of the float stem. The following combinations are not possible: Stop positions A & B, A & E, A & H, A & K, B & C, B & K, C & D, C & K, C & L, D & L, E & F, E & H, F & H, F & J, F & G and G & J.

1.6 Interface

Each interface unit is calibrated at the factory by precise positioning of the calibration weight on the float stem. Do not attempt to adjust calibration in the field. Calibration weight should not be moved. If unit does not function properly in interface service, consult factory.

2.0 Reference Information

This section presents an overview of the operation of the TUFFY II Liquid Level Switches, including information on troubleshooting common problems, maintenance procedures, listings of agency approvals, lists of replacement and recommended spare parts, and detailed physical, functional, and performance specifications.

2.1 Description

The TUFFY II Liquid Level Switches are float actuated devices designed for horizontal mounting in a tank or vessel through threaded or flanged pipe connections. The compact size allows for installation in small vessels while its many features provide a variety of application uses. The single switch mechanism is available in SPDT or DPDT forms on units designed for fixed or adjustable, narrow or wide differential, interface service and offset levels. This manual covers TUFFY II level switches that have electric switches. For TUFFY with a pneumatic switch, see bulletin 44-606.

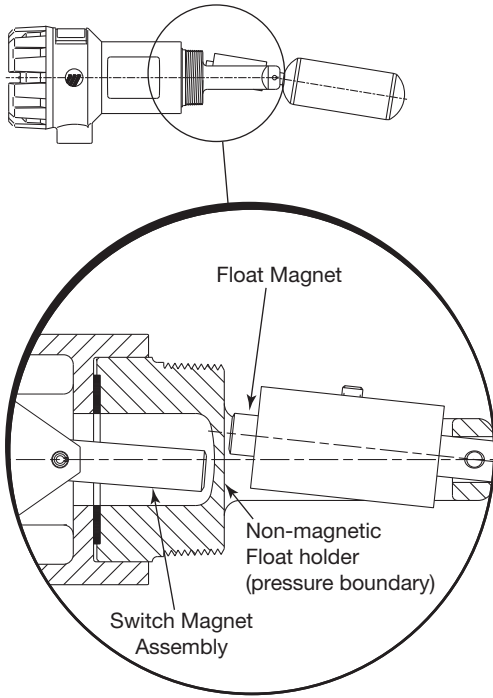

Figure 11
Magnet/Switch Action

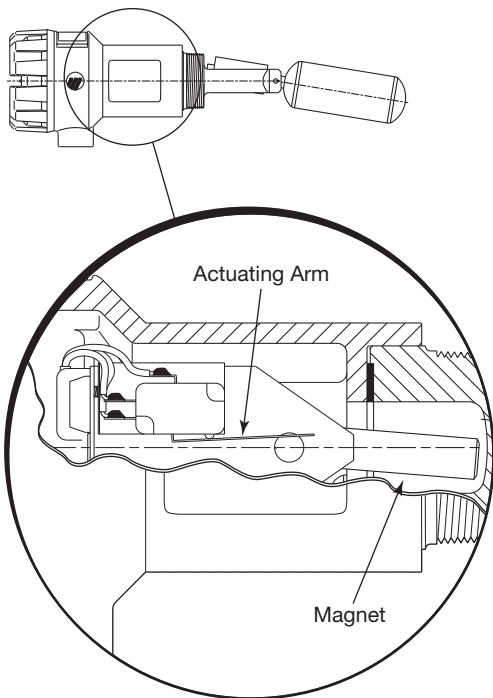

Figure 12
Switch Actuating Arm and Magnet Assembly

2.2 Theory of Operation

The TUFFY II achieves switching action through the use of a magnetic switch mechanism and a magnet attached to the float assembly. Separating the two magnets is a non-magnetic pressure barrier.

The float along with the float magnet moves as the liquid level changes. The float and switch magnets repel each other causing movement of the switch magnet assembly, tripping the switch and making or breaking an electrical circuit.

See Figure 11.

2.3 Troubleshooting

The TUFFY II Liquid Level Switch is designed and engineered for trouble-free operation. Common problems are discussed in terms of their symptoms and corrective actions as recommended.

2.3.1 External Causes

Usually the first indication of improper operation is failure of the controlled equipment to function; i.e., pump will not start (or stop), signal lamps fail to light, etc. When these symptoms occur, whether at the time of installation or during routine service thereafter, check for the following potential external causes first:

- Blown fuses
- Tripped reset button(s)
- Open power switch
- Faulty equipment controlled by level switch
- Defective wiring to level switch

2.3.2 Tuffy® II Causes

If a thorough inspection of these possible conditions fails to locate the cause of the problem, proceed to a check of the TUFFY II switch mechanism.

1. Disconnect power to the level switch.
2. Remove switch housing cover.
3. Disconnect power wiring from switch mechanism.
4. Examine the switch actuating arm and magnet assembly for evidence of binding or wiring interference. **See Figure 12.** The switch and magnet assembly must move throughout its entire range of motion without interference. If there is any binding, the ENTIRE switch mechanism (switch and magnet assembly) must be replaced.

-
5. If the switch mechanism does not move freely, use an electrical continuity checker to determine if the switch is electrically functional. Refer to **Figures 5, 6, 7 & 8** on page 6 for the appropriate wiring diagram. If the switch operates properly when moved mechanically but not when electrically activated, the switch must be replaced.
 6. If the switch functions properly both mechanically and electrically but does not activate when the float changes position, remove level switch from service. Check the float assembly for obstructions or accumulation of particles which may cause binding. If binding is present in the float assembly and cannot be cleared by normal cleaning procedures, the entire control must be replaced.
 7. If the complete TUFFY II level switch operates properly when removed from service, check to ensure that liquid is entering the tank or vessel. A closed valve or clogged pipeline may prevent movement of the liquid in the vessel.
 8. Check the float to make sure it is buoyant in the liquid (tank or vessel must have adequate level).
 9. If the float is determined to be filled with liquid or is collapsed, the entire level switch must be replaced. Do not attempt to repair the float.

If all the components of the level switch are in operating condition, the trouble is located external to the level switch. Repeat inspection of external conditions as described in *Section 2.3.1, External Causes*.

NOTE: When in doubt about the condition or performance of a TUFFY II control, consult the factory for further instructions.

2.4 Preventive Maintenance

Periodic inspections are a necessary means to keep your level control in good working order. This control is a safety device that protects the valuable equipment it serves. A systematic program of preventive maintenance should be implemented when the control is placed into service. If the following instructions are observed, your control will provide reliable protection of your equipment for many years.

2.4.1 What to Do

1. Keep control clean.

Be sure the switch housing cover is always in place. This cover is designed to keep dust and dirt from interfering with the switch mechanism operation. It also protects against damaging moisture and acts as a safety feature by keeping bare wires and terminals from being exposed. Should the housing cover become damaged or misplaced, obtain a replacement immediately.

2. Inspect switch mechanisms, terminals, and connections monthly.

TUFFY II level switches may at times be exposed to excessive heat or moisture. Under such conditions insulation on electrical wires may become brittle, eventually breaking or peeling away. The resulting bare wires can cause short circuits. Check wiring carefully and replace at the first sign of brittle insulation.

Vibration may sometimes cause terminal screws to loosen. Check all terminal connections to ensure that screws are tight. Check wiring carefully and repair or replace if necessary.

NOTE: It is recommended that spare switches, housing covers and O-rings be kept on hand at all times.

3. Inspect entire TUFFY II unit periodically.

A periodic cleaning of the float and counterweight assembly will ensure continued free movement of the mechanism.

2.4.2 What to Avoid

1. NEVER leave the switch housing cover off of the control longer than is necessary to make routine inspections.
2. NEVER place a jumper wire across terminals to “cut-out” the control. If a jumper is necessary for test purposes, ensure that it is removed before placing the control into service.
3. NEVER attempt to make adjustments to or replace switches without reading instructions carefully. When in doubt, consult the factory or your local representative.
4. NEVER use in systems containing iron particles. The magnet in the float assembly can attract the particles and become jammed.
5. NEVER put insulation over the switch housing.





2.4.3 Switch Mechanism Replacement

1. Have the proper replacement switch mechanism on hand. See *Section 2.6.1* on page 14 for replacement parts.
2. Remove housing cover.
3. Remove the four screws in the corners of the switch mounting bracket and remove switch mechanism and magnet assembly.
4. Place new mechanism into the housing.

NOTE: Looking into the switch housing with the conduit connection pointing downward, the correct orientation of the switch mechanism is with the green head ground screw on the right hand side of the enclosure.

5. Once it is properly placed, secure the mechanism into the housing by replacing the four screws in the corners of the mounting bracket.
6. By moving the level in the vessel or by moving the float by hand, ensure that the switch actuates properly.
7. Replace housing cover.

2.5 Agency Approvals

AGENCY	APPROVED MODEL	PROTECTION METHOD	AREA CLASSIFICATION
FM 	T3X-XXXX-XXA T3X-XXXX-XXB	Explosion Proof	Class I, Div 1; Groups B, C, D Class II, Div 1; Groups E, F, G Class III, Type 4X IP66
CSA 	T3X-XXXX-XXC T3X-XXXX-XXD	Explosion Proof	Class I, Div 1; Groups B, C, D Class II, Div 1; Groups E, F, G Class III, Div 1; Type 4X
ATEX 	T3X-XXXX-XX1 T3X-XXXX-XX2 T3X-XXXX-XX3 T3X-XXXX-XX4	Flame Proof Certificate ISSeP10ATEX032, applied standards EN60079-0:2009, EN60079-1:2007 and EN60079-26:2007	II 1/2 G Ex d II C T6 Ga/Gb IP66
	T3X-XXXX-XXM T3X-XXXX-XXN T3X-XXXX-XXP T3X-XXXX-XXR	Intrinsically Safe ① Certificate ISSeP00ATEX010X applied standards EN50014:1999, EN50020:1994 and EN50284:1999	II 1G EEx ia II C T6/T4 IP66
IEC	T3X-XXXX-XX1 T3X-XXXX-XX2 T3X-XXXX-XX3 T3X-XXXX-XX4	Flame Proof Certificate BK113.0006 applied standards IEC60079-0:2011, IEC60079-1:2007, IEC60079-26:2006	Exd IIC T6 Ga/Gb IP66
CE 	T3X-XXXX-XXX	Low Voltage Directives 2006/95/EC Per Horizontal Standard: EN 61010-1/1993 & Amendment No.	Installation Category II Pollution Degree 2

Special conditions for safe use:

- ① When the material is equipped with an aluminum enclosure, all precautions shall be taken to avoid all impacts or frictions which can result in the ignition of the potentially explosive atmosphere.

2.6 Parts

2.6.1 Replacement Parts

Switch Mechanisms	SPDT silver contacts	31-5144-001
	DPDT silver contacts	31-5146-001
	SPDT gold contacts	31-5144-002
	DPDT gold contacts	31-5146-002
	HS SPDT silver contacts	31-5145-001
	HS SPDT gold contacts	31-5145-002
Housing Cover	FM/CSA XP Cast Aluminum	089-6609-001
	FM/CSA XP Cast Iron	089-6609-002
	ATEX XP Cast Aluminum	089-6609-003
	ATEX XP Cast Iron	089-6609-004
	ATEX IS Cast Aluminum	089-6609-005
	ATEX IS Cast Iron	089-6609-006
Cover O-ring		12-2201-240

2.6.2 Recommended Spare Parts

Item	Description	Part Number
1	Switch Mechanism	See replacement parts chart.

2.7 Specifications

2.7.1 Functional

Output

Type	Switch closure, SPDT or DPDT
Ratings	Up to 10 amps @ 120 or 240 VAC, 50–60 Hz Up to 6 amps @ 24 VDC \equiv Up to 0.6 amps @ 120 VDC \equiv
Contacts	Silver, gold plated, hermetically sealed silver, hermetically sealed gold plated

Housing

Material	Polymer coated cast aluminum or cast iron
Cable entry	$\frac{3}{4}$ " NPT

Process Connections

Materials	Carbon Steel 316/316L stainless steel Hastelloy C 316/316L stainless steel clad carbon steel Hastelloy C clad carbon steel
Configurations	Tank 2" NPT, 3", 4", 5" & 6" ANSI Flange Chambered: 1" top-bottom NPT

Wetted parts

Float & Trim	316/316L stainless steel or Hastelloy C
--------------	---

Process Conditions

Process temperature range	-40° to +750° F (-40° to +400° C) with ambient temperature within range specified below
Maximum process pressure	2630 psig @ +100° F (181 bar @ +38° C)
Liquid specific gravity	0.40 or greater

Environmental

Ambient temperature range	0° to +100° F (-18° to +38° C) For ambient temperature outside this range, derate maximum process temperature per charts on pages 16–18.
---------------------------	---

2.7.2 Performance

Repeatability	± 0.25 " (± 6 mm)
---------------	----------------------------

2.7.3 Switch Temperature Ratings

Process Temp Range:

HS with silver contacts

HS with gold contacts

Snap with silver contacts

Snap with gold contacts

Cast Iron Housing

-65° to +750° F (-54° to +399° C)

-65° to +750° F (-54° to +399° C)

-40° to +750° F (-40° to +399° C)

-40° to +375° F (-40° to +190° C)

Cast Aluminum Housing

-65° to +650° F (-54° to +343° C)

-65° to +650° F (-54° to +343° C)

-40° to +650° F (-40° to +343° C)

-40° to +325° F (-40° to +162° C)

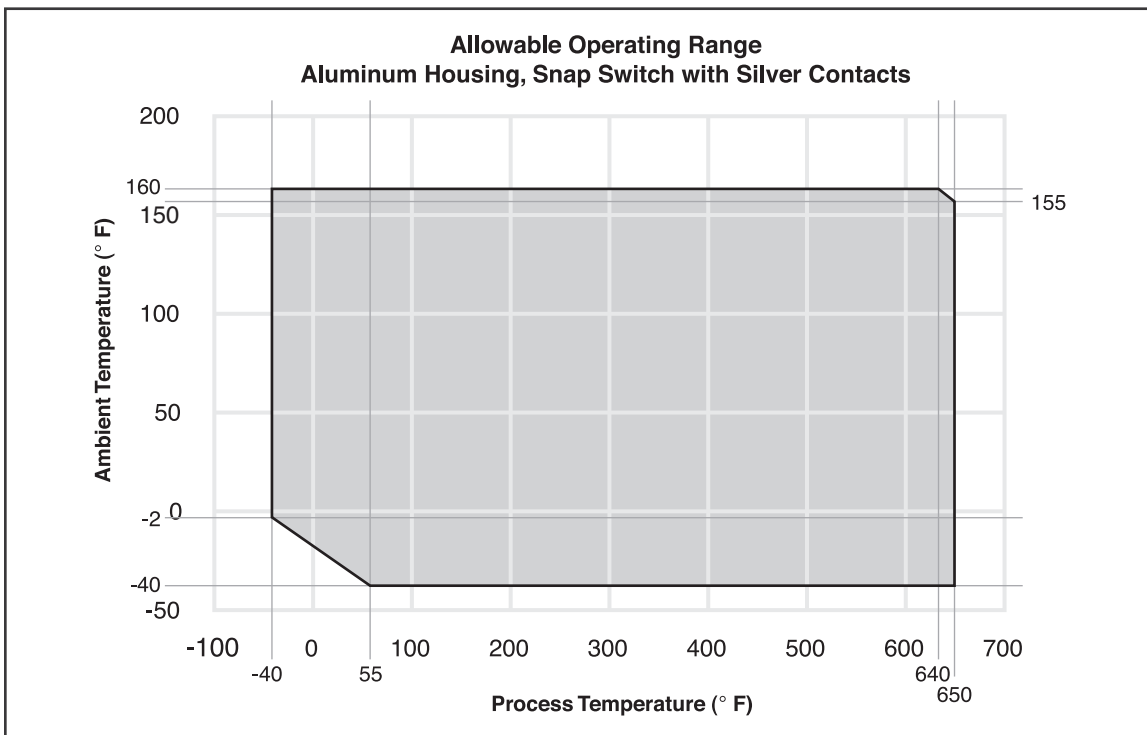
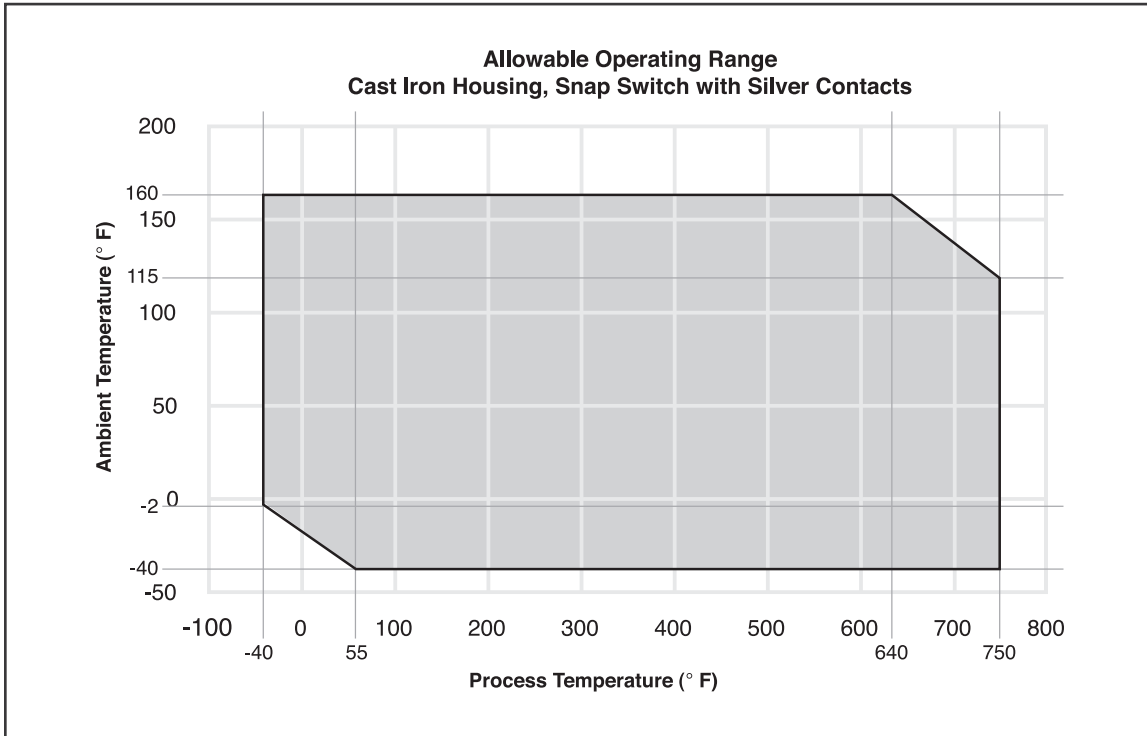

2.7.3 Switch Temperature Ratings (continued)

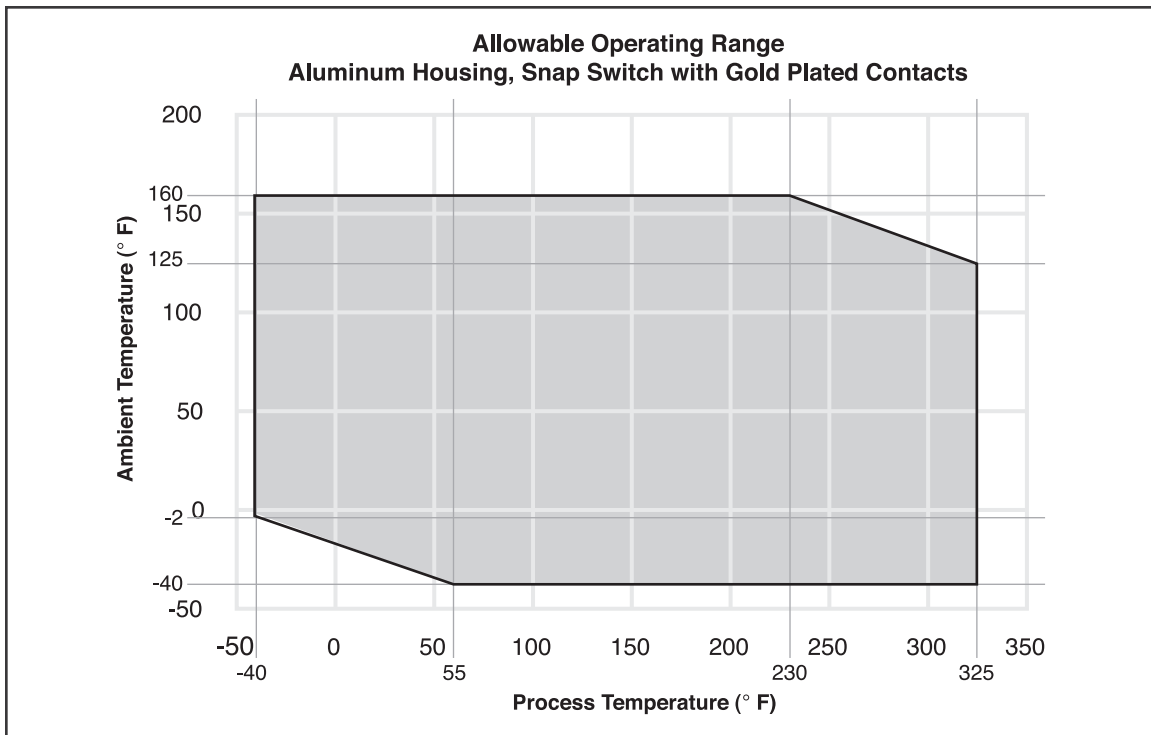
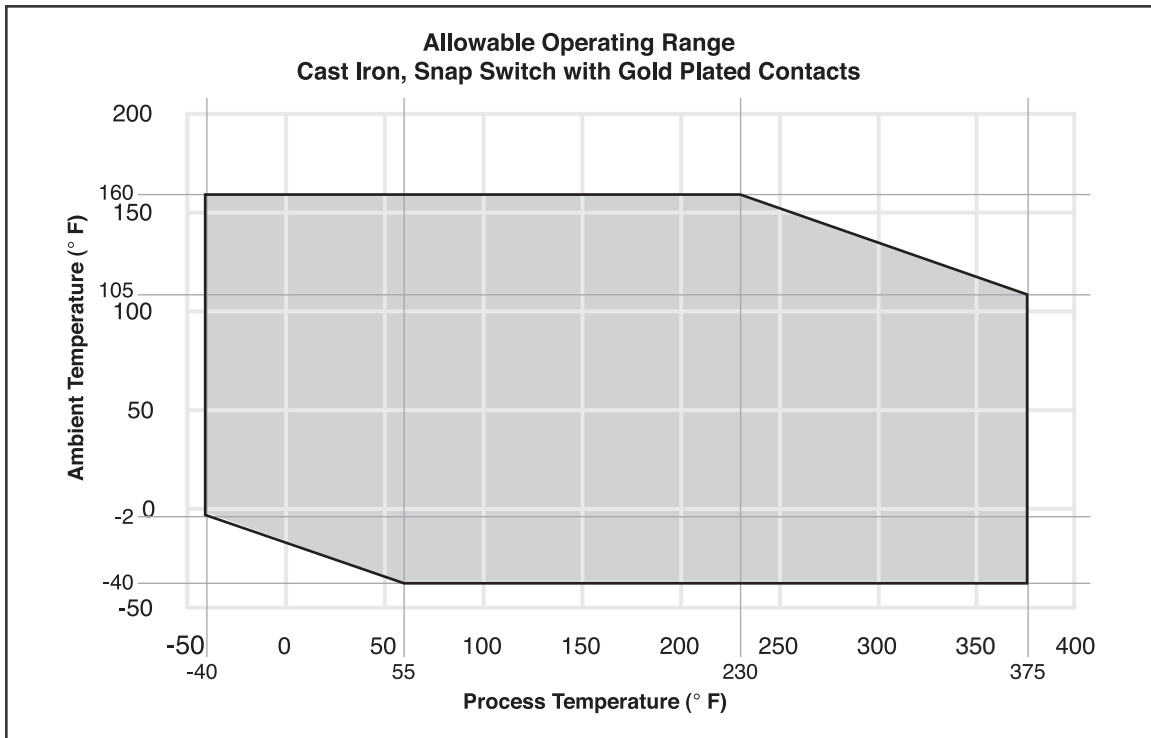

2.7.3 Switch Temperature Ratings (continued)

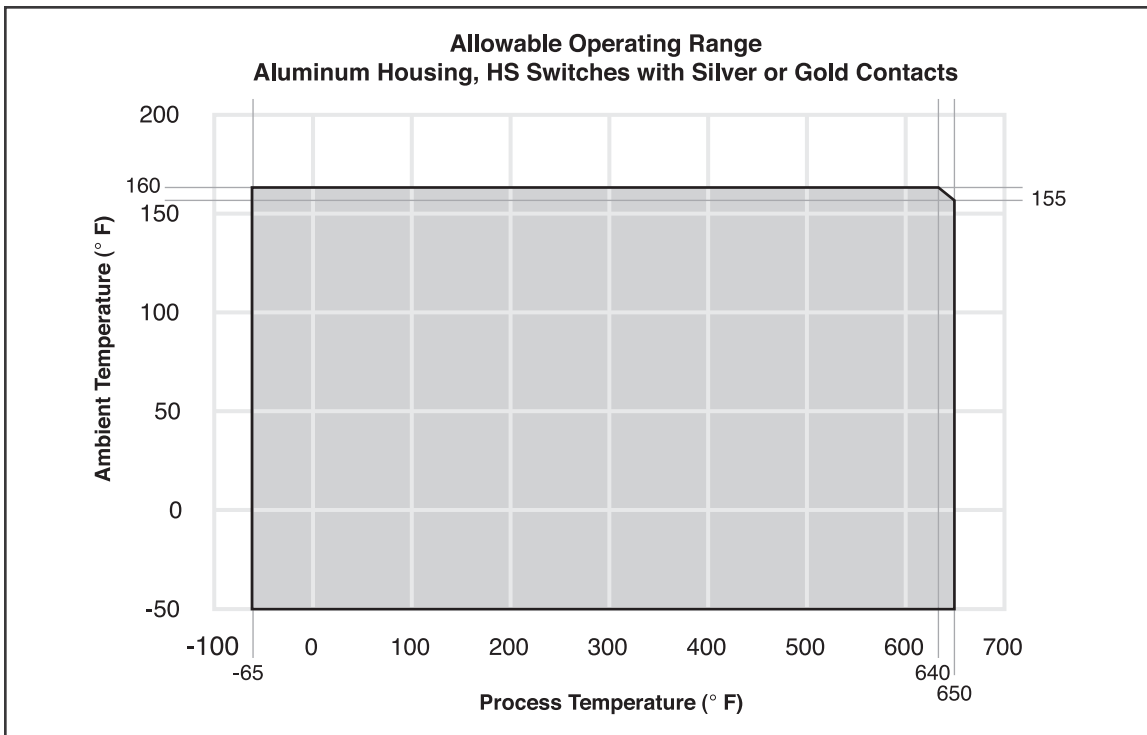
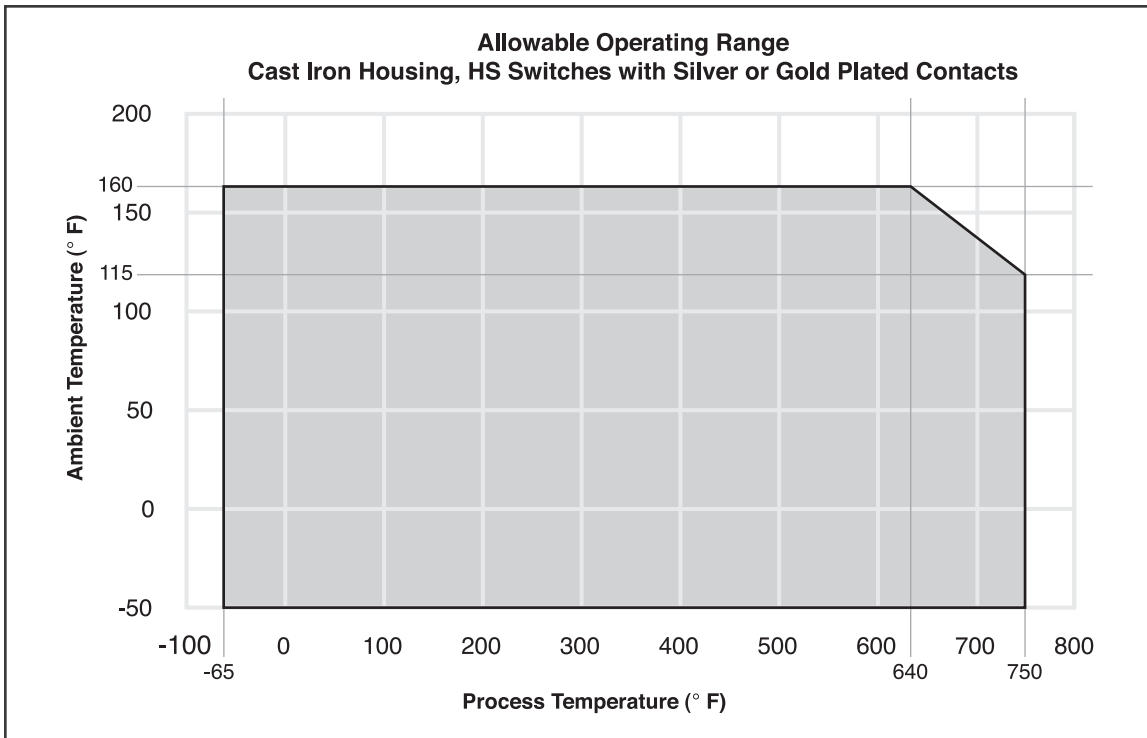

2.7.4 Physical

Dimensional Specifications – inches (mm)

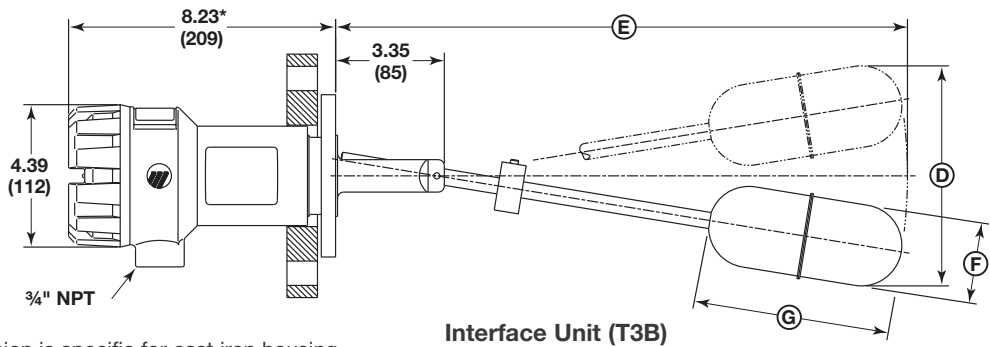
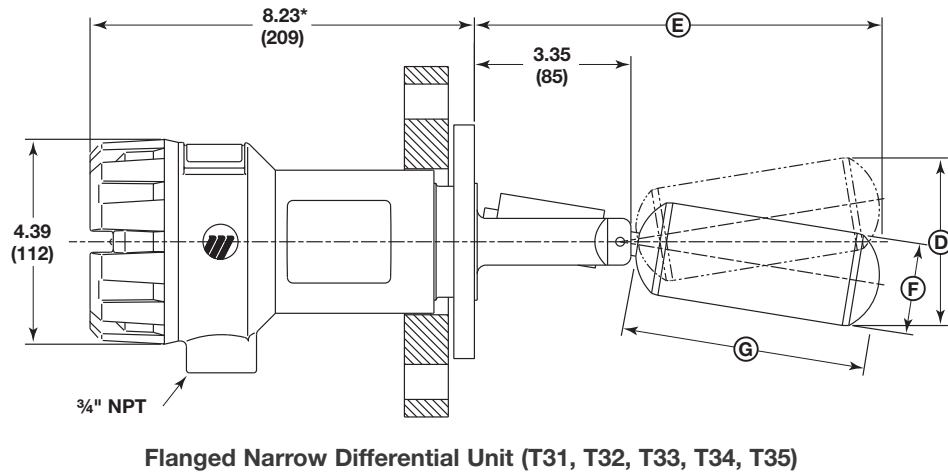
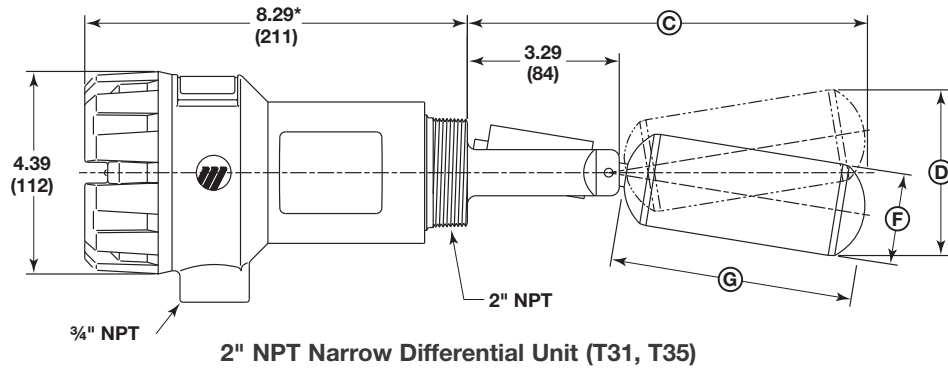

* This dimension is specific for cast iron housing.
Subtract 0.31" for aluminum housing.

Inches (mm)

Dimension	T31	T32	T33	T34	T35	T3B	T3C		
B	—	—	—	—	—	—	3.75 (95)	7.5 (190)	12.25 (311)
C	8.66 (220)	—	—	—	7.86 (199)	—	—	—	—
D	3.59 (91)	3.36 (85)	3.58 (91)	3.59 (91)	3.33 (85)	6.78 (172)	13.62 (346)	18.54 (471)	24.76 (629)
E	8.72 (221)	8.02 (204)	7.50 (190)	7.97 (202)	7.92 (201)	17.62 (448)	12.86 (327)	16.61 (422)	21.36 (543)
F	2.00 (51)	2.00 (51)	2.38 (60)	2.00 (51)	2.00 (51)	2.66 (68)	2.66 (68)		
G	5.25 (133)	4.55 (116)	4.00 (102)	4.50 (114)	4.45 (113)	6.00 (152)	6.00 (152)		
Maximum Nozzle Length	3.29 (84)	3.35 (85)	3.35 (85)	3.35 (85)	3.29 (84)	5.80 (147)	4.35 (110)		

2.7.4 Physical (continued)

Dimensional Specifications – inches (mm)

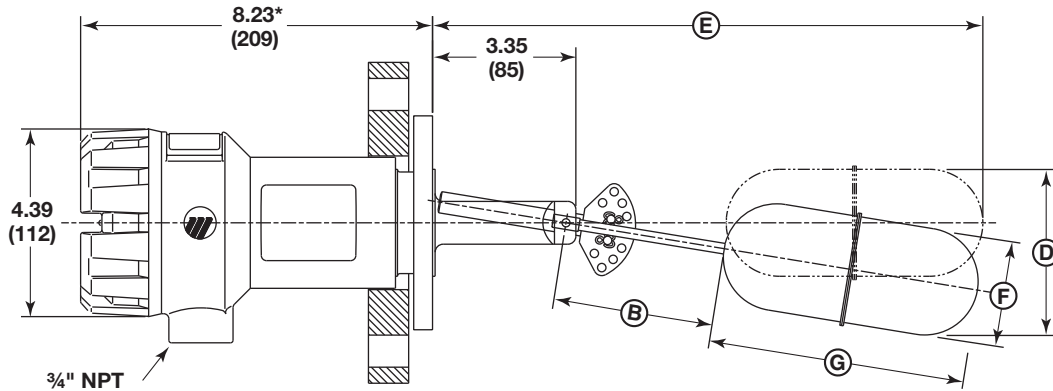

Adjustable Differential Unit (T3C)
 (See model number on page 26 for dimension B)

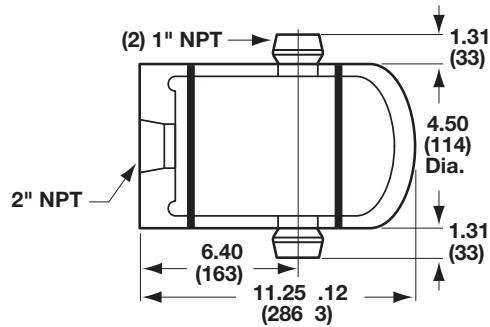

Tuffy® Chamber

* This dimension is specific for cast iron housing.
 Subtract 0.31" for aluminum housing.

2.8 Model Numbers

Narrow Differential: Switch differential of approximately 0.5" (1.7" on interface unit), for actuation of an alarm or system shutdown.

Interface Service: Switch to detect the interface between two liquids with SGUs that differ by at least 0.1.

Single Liquid: Switch to detect the top of layer of a single liquid with no other liquid above it.

Adjustable Differential: Wide switch differential from approximately 1.36" to 18.26" which may be adjusted in the field by repositioning pins on the adjustment plate.

Basic Model Flow Chart

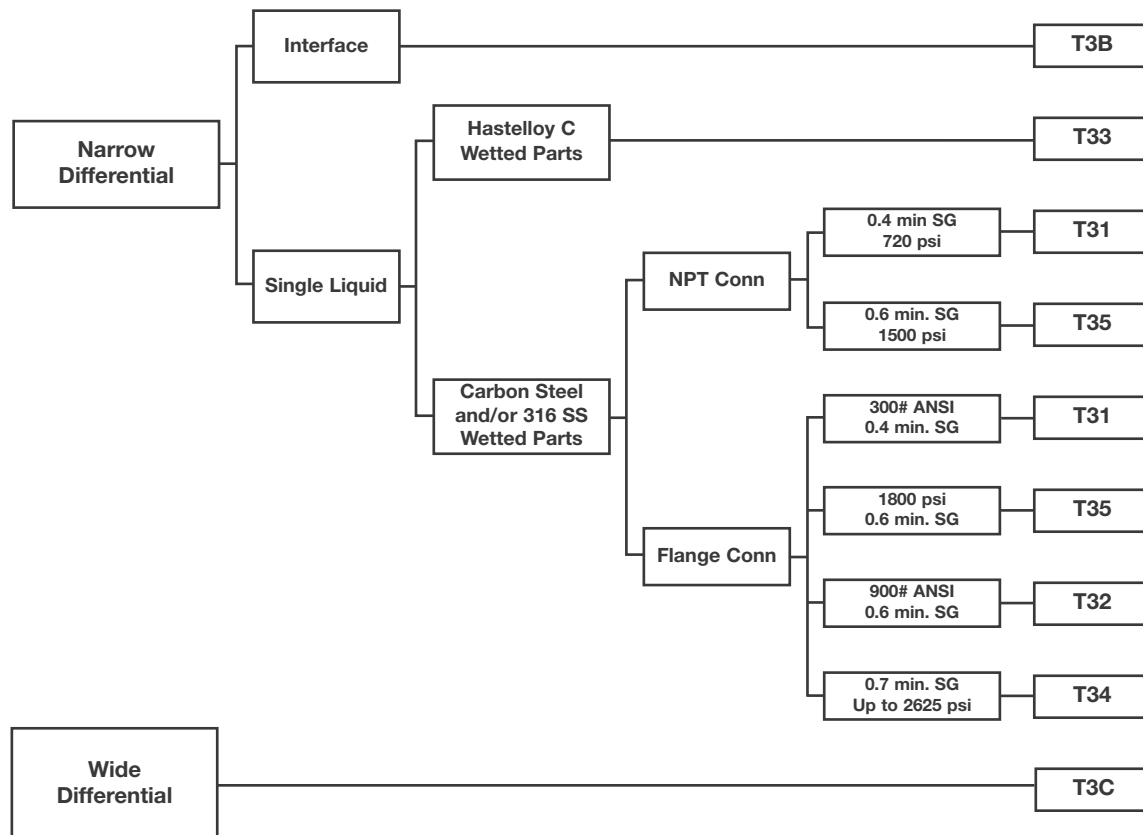

See following pages for complete model selection

2.8 Model Numbers

2.8.1 Standard Narrow Differential Models

BASIC MODEL NUMBER

T 3	TUFFY II Electric Liquid Level Switch
-----	---------------------------------------

FUNCTION/FLOAT

Code	Level Differential	SGU Min	Max. ① Pressure psig (bar)	Compatible Model Codes		
				Process Connection Size Codes	Process Connection Type Codes	Process Connection Material/Design Codes
1	Narrow (0.5")	0.40	750 (52)	All	N, A, B	A,B,E,F,J,K,N,P,1,2
2		0.60	2220 (153)	3, 4, 5, 6	A, B, C, D	A,B,E,F,J,K,N,P,1,2
3		0.65	750 (52)	3, 4, 5, 6	A, B	C,D,G,H,L,M,R,T
4		0.70	2630 (181)	4	E	A,B,E,F,J,K,N,P,1,2
5		0.60	1800 (124)	All	N, A, B, C	A,B,E,F,J,K,N,P,1,2

PROCESS CONNECTION SIZE

Code	Size	Compatible Model Codes		
		Function/Float Codes	Process Connection Type Codes	Process Connection Material/Design Codes
2	2"	1, 5	N	B, F, K, P
3	ANSI 3"	1, 2, 3, 5	A, B, C, D	All
4	ANSI 4"	1, 2, 3, 4, 5	A, B, C, D, E	All
5	ANSI 5"	1, 2, 3, 5	A, B	All
6	ANSI 6"	1, 2, 3, 5	A, B	All

PROCESS CONNECTION TYPE ①

Code	Type	Compatible Model Codes		
		Function/Float Codes	Process Connection Size Codes	Process Connection Material/Design Codes
N	NPT	1, 5	2	B, F, K, P
A	ANSI RF Flange, 150#	1, 2, 3, 5	3, 4, 5, 6	All
B	ANSI RF Flange, 300#	1, 2, 3, 5	3, 4, 5, 6	All
C	ANSI RF Flange, 600#	2, 5	3, 4	A, B, E, F, J, K, N, P, 1, 2
D	ANSI RF Flange, 900#	2, 5	3, 4	A, B, E, F, J, K, N, P, 1, 2
E	ANSI RF Flange, 1500#	4	4	A, B, E, F, J, K, N, P, 1, 2

PROCESS CONNECTION MATERIAL/DESIGN CODE

SWITCH TYPE

HOUSING MATERIAL/APPROVAL

See opposite page

① Rated pressure limited by maximum Float or Flange pressure, whichever is less.

T	3		0	0			
---	---	--	---	---	--	--	--

complete order code for
TUFFY II Float Level Switch

2.8 Model Numbers

2.8.1 Standard Narrow Differential Models (continued)

PROCESS CONNECTION MATERIAL/DESIGN CODE

Standard	ASME B31.1 & ASME B31.3	NACE	ASME B31.1, ASME B31.3 & NACE	Process Connection Material	Compatible Model Codes		
					Function/Float Codes	Process Connection Size Codes	Process Connection Type Codes
1	2	N/A	N/A	Carbon Steel Flange and cladding with 316/316L SS float holder & trim	1, 2, 4, 5	3, 4, 5, 6	A, B, C, D, E
A	E	J	N	Carbon Steel Flange with 316/316L SS process wetted face	1, 2, 4, 5	3, 4, 5, 6	A, B, C, D, E
B	F	K	P	All 316/316L Stainless Steel	1, 2, 4, 5	All	All
C	G	L	R	Carbon Steel Flange with Hastelloy C process wetted face	3	3, 4, 5, 6	A, B
D	H	M	T	All Hastelloy C	3	3, 4, 5, 6	A, B

SWITCH TYPE

Code	Contact Type and Material	Electric Switch Rating				Maximum Process Temperature ①②	
		VAC		VDC		Cast Iron Housing	Cast Alum. Housing
		120	240	24	120		
0	SPDT w/silver contacts	10.0	10.0	6.0	0.6	+750° F (+399° C)	650° F (+343° C)
1	DPDT (dual SPDT) w/silver contacts	10.0	10.0	6.0	0.6	+750° F (+399° C)	650° F (+343° C)
2	SPDT w/gold plated contacts	0.1	—	0.1	—	+375° F (+190° C)	325° F (+162° C)
3	DPDT (dual SPDT) w/gold plated contacts	0.1	—	0.1	—	+375° F (+190° C)	325° F (+162° C)
4	HS SPDT w/silver contacts	1.0	1.0	3.0	0.5	+750° F (+399° C)	650° F (+343° C)
6	HS SPDT w/gold plated contacts	0.5	0.5	0.5	0.5	+750° F (+399° C)	650° F (+343° C)

① Maximum process temperature is based on an ambient temperature between 0° and +100° F (-18° and +30° C). For ambients outside this range, see switch temperature charts on pages 16-18.

② See Switch Temperature Ranges on page 16 for minimum process temperatures.

HOUSING MATERIAL/APPROVAL

FM	CSA	ATEX Ex d	ATEX IS	IEC Ex d	
A	C	1	M	1	Cast Aluminum, 3/4" NPT Conduit Entry
B	D	2	N	2	Cast Iron, 3/4" NPT Conduit Entry
N/A		3	P	3	Cast Aluminum, M20 x 1.5 Conduit Entry
		4	R	4	Cast Iron, M20 x 1.5 Conduit Entry

--	--	--

2.8.2 Chamber Model Number

MATERIALS OF CONSTRUCTION/PRESSURE RATING

0-001	Carbon Steel	2200 psig @ +400° F (152 bar @ +204° C), 1400 psig @ +750° F (97 bar @ +399° C)
0-002	316 Stainless Steel	2500 psig @ +400° F (172 bar @ +204° C), 2013 psig @ +750° F (139 bar @ +399° C)
1-001	Carbon Steel	1200 psig @ +400° F (83 bar @ +204° C), 780 psig @ +750° F (54 bar @ +399° C)
1-002	316 Stainless Steel	1400 psig @ +400° F (97 bar @ +204° C), 1127 psig @ +750° F (78 bar @ +399° C)

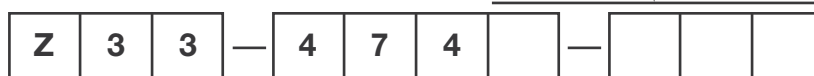

Note: Flanged chambers and process flanges available. Consult factory.

2.8 Model Numbers

2.8.3 Interface Models

Process Connection:	ANSI Flanges
Wetted Materials:	Carbon steel and/or 316/316L SS
Max. Float Pressure:	750 psi (52 bar) ①
Min. SG of Lower Liquid:	0.81
Min SG difference:	0.1
Level Differential:	1.72" (HL=0.82" LL=1.06")

BASIC MODEL NUMBER

T 3	TUFFY II Electric Liquid Level Switch
-----	---------------------------------------

FUNCTION/FLOAT

B	Interface Level
---	-----------------

LOWER FLUID SPECIFIC GRAVITY

0.81	0.82	0.83	0.84	0.85	0.86	0.87	0.88	0.89	0.90	Specific Gravity
A	B	C	D	E	F	G	H	J	K	Code
0.91	0.92	0.93	0.94	0.95	0.96	0.97	0.98	0.99	1.00	Specific Gravity
L	M	N	P	R	S	T	U	V	W	Code

PROCESS CONNECTION SIZE

3	ANSI 3"
4	ANSI 4"
5	ANSI 5"
6	ANSI 6"

PROCESS CONNECTION TYPE ①

A	ANSI RF Flange, 150#
B	ANSI RF Flange, 300#

① Rated pressure limited by maximum Float or Flange pressure, whichever is less.

PROCESS CONNECTION MATERIAL/DESIGN CODE
SWITCH TYPE
HOUSING MATERIAL/APPROVAL
 See opposite page

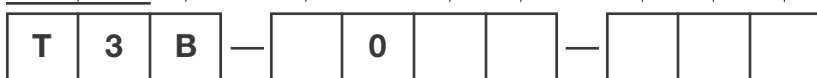

complete order code for
TUFFY II Float Level Switch

2.8 Model Numbers

2.8.3 Interface Models (continued)

PROCESS CONNECTION MATERIAL/DESIGN CODE

Standard	ASME B31.1 & ASME B31.3	NACE	ASME B31.1, ASME B31.3 & NACE	Process Connection Material
1	2	N/A	N/A	Carbon Steel Flange and cladding with 316/316L SS float holder & trim
A	E	J	N	Carbon Steel Flange with 316/316L SS process wetted face
B	F	K	P	All 316/316L Stainless Steel

SWITCH TYPE

Code	Contact Type and Material	Electric Switch Rating				Maximum Process Temperature ^{①②}	
		VAC		VDC		Cast Iron Housing	Cast Alum. Housing
		120	240	24	120		
0	SPDT w/silver contacts	10.0	10.0	6.0	0.6	+750°F (+399° C)	650°F (+343° C)
1	DPDT (dual SPDT) w/silver contacts	10.0	10.0	6.0	0.6	+750°F (+399° C)	650°F (+343° C)
2	SPDT w/gold plated contacts	0.1	—	0.1	—	+375°F (+190° C)	325°F (+162° C)
3	DPDT (dual SPDT) w/gold plated contacts	0.1	—	0.1	—	+375°F (+190° C)	325°F (+162° C)
4	HS SPDT w/silver contacts	1.0	1.0	3.0	0.5	+750°F (+399° C)	650°F (+343° C)
6	HS SPDT w/gold plated contacts	0.5	0.5	0.5	0.5	+750°F (+399° C)	650°F (+343° C)

① Maximum process temperature is based on an ambient temperature between 0° and +100° F (-18° and +30° C). For ambients outside this range, see switch temperature charts on pages 16–18.

② See Switch Temperature Ranges on page 16 for minimum process temperatures.

HOUSING MATERIAL/APPROVAL

FM	CSA	ATEX Ex d	ATEX IS	IEC Ex d	
A	C	1	M	1	Cast Aluminum, ¾" NPT Conduit Entry
B	D	2	N	2	Cast Iron, ¾" NPT Conduit Entry
N/A		3	P	3	Cast Aluminum, M20 × 1.5 Conduit Entry
		4	R	4	Cast Iron, M20 × 1.5 Conduit Entry

--	--	--

2.8 Model Numbers

2.8.4 Adjustable Wide Differential Models

Process Connection:	ANSI Flanges
Wetted Materials:	Carbon steel and/or 316/316L SS
Max. Float Pressure:	750 psi (51 bar) ①
Min SG:	0.78
Level Differential:	Adjustable from 1.36" to 18.26"

BASIC MODEL NUMBER

T 3	TUFFY II Electric Liquid Level Switch
-----	---------------------------------------

FUNCTION/FLOAT

C	Adjustable Differential Level
---	-------------------------------

STEM EXTENSION LENGTH "B" DIMENSION (See page 20)

4	3.75 inch (95 mm) stem extension
8	7.50 inch (190 mm) stem extension
C	12.25 inch (311 mm) stem extension

PROCESS CONNECTION SIZE

3	ANSI 3"
4	ANSI 4"
5	ANSI 5"
6	ANSI 6"

PROCESS CONNECTION TYPE ①

A	ANSI RF Flange, 150#
B	ANSI RF Flange, 300#

① Rated pressure limited by maximum Float or Flange pressure, whichever is less.

PROCESS CONNECTION MATERIAL/DESIGN CODE

SWITCH TYPE

HOUSING MATERIAL/APPROVAL

See opposite page



complete order code for
TUFFY II Float Level Switch

2.8 Model Numbers

2.8.4 Adjustable Wide Differential Models (continued)

PROCESS CONNECTION MATERIAL/DESIGN CODE

Standard	ASME B31.1 & ASME B31.3	NACE	ASME B31.1, ASME B31.3 & NACE	Process Connection Material
1	2	N/A	N/A	Carbon Steel Flange and cladding with 316/316L SS float holder & trim
A	E	J	N	Carbon Steel Flange with 316/316L SS process wetted face
B	F	K	P	All 316/316L Stainless Steel

SWITCH TYPE

Code	Contact Type and Material	Electric Switch Rating				Maximum Process Temperature ^{①②}	
		VAC		VDC		Cast Iron Housing	Cast Alum. Housing
		120	240	24	120		
0	SPDT w/silver contacts	10.0	10.0	6.0	0.6	+750°F (+399° C)	650°F (+343° C)
1	DPDT (dual SPDT) w/silver contacts	10.0	10.0	6.0	0.6	+750°F (+399° C)	650°F (+343° C)
2	SPDT w/gold plated contacts	0.1	—	0.1	—	+375°F (+190° C)	325°F (+162° C)
3	DPDT (dual SPDT) w/gold plated contacts	0.1	—	0.1	—	+375°F (+190° C)	325°F (+162° C)
4	HS SPDT w/silver contacts	1.0	1.0	3.0	0.5	+750°F (+399° C)	650°F (+343° C)
6	HS SPDT w/gold plated contacts	0.5	0.5	0.5	0.5	+750°F (+399° C)	650°F (+343° C)

① Maximum process temperature is based on an ambient temperature between 0° and +100° F (-18° and +30° C). For ambients outside this range, see switch temperature charts on pages 16–18.

② See Switch Temperature Ranges on page 16 for minimum process temperatures.

HOUSING MATERIAL/APPROVAL

FM	CSA	ATEX Ex d	ATEX IS	IEC Ex d	
A	C	1	M	1	Cast Aluminum, ¾" NPT Conduit Entry
B	D	2	N	2	Cast Iron, ¾" NPT Conduit Entry
N/A		3	P	3	Cast Aluminum, M20 × 1.5 Conduit Entry
		4	R	4	Cast Iron, M20 × 1.5 Conduit Entry

--	--	--

Service Policy

Owners of MAGNETROL may request the return of a control or any part of a control for complete rebuilding or replacement. They will be rebuilt or replaced promptly. Controls returned under our service policy must be returned by Prepaid transportation. MAGNETROL will repair or replace the control at no cost to the purchaser (or owner) other than transportation if:

1. Returned within the warranty period; and
2. The factory inspection finds the cause of the claim to be covered under the warranty.

If the trouble is the result of conditions beyond our control; or, is NOT covered by the warranty, there will be charges for labor and the parts required to rebuild or replace the equipment.

In some cases it may be expedient to ship replacement parts; or, in extreme cases a complete new control, to replace the original equipment before it is returned. If this is desired, notify the factory of both the model and serial numbers of the control to be replaced. In such cases, credit for the materials returned will be determined on the basis of the applicability of our warranty.

No claims for misapplication, labor, direct or consequential damage will be allowed.

Return Material Procedure

So that we may efficiently process any materials that are returned, it is essential that a "Return Material Authorization" (RMA) number be obtained from the factory, prior to the material's return. This is available through a MAGNETROL local representative or by contacting the factory. Please supply the following information:

1. Company Name
2. Description of Material
3. Serial Number
4. Reason for Return
5. Application

Any unit that was used in a process must be properly cleaned in accordance with OSHA standards, before it is returned to the factory.

A Material Safety Data Sheet (MSDS) must accompany material that was used in any media.

All shipments returned to the factory must be by prepaid transportation.

All replacements will be shipped F.O.B. factory.



705 Enterprise Street • Aurora, Illinois 60504-8149 • 630-969-4000 • Fax 630-969-9489
info@magnetrol.com • www.magnetrol.com

Copyright © 2016 Magnetrol International, Incorporated. All rights reserved. Printed in the USA.
Performance specifications are effective with date of issue and are subject to change without notice.

Magnetrol & Magnetrol logotype and Tuffy are registered trademarks of Magnetrol International, Incorporated.
Teflon is a registered trademark of DuPont.

BULLETIN: 44-607.13
EFFECTIVE: January 2016
SUPERSEDES: January 2014