



USER INSTRUCTIONS

DDC-100 Field Unit with Ethernet

FCD LMENIM2329-02 – 05/17

Installation
Operation
Maintenance



DDC-100 Field Unit Installation and Operation Manual

©2017 Copyright Limatorque. All rights reserved. Printed in the United States of America.

Disclaimer

This document is meant for use with Limatorque actuator Installation and Operation Manuals. No part of this book shall be reproduced, stored in a retrieval system, or transmitted by any means, electronic, mechanical, photocopying, recording, or otherwise without the written permission of Limatorque. While every precaution has been taken in the preparation of this book, the publisher assumes no responsibility for errors or omissions. Neither is any liability assumed for damages resulting from the use of the information contained herein.

This document is the proprietary information of Limatorque, furnished for customer use ONLY. No other uses are authorized without written permission from Limatorque.

Limatorque reserves the right to make changes, without notice, to this document and the product it describes. Limatorque shall not be liable for technical or editorial errors or omissions made herein; nor for incidental and consequential damages resulting from the furnishing, performance or use of this document.

The choice of system components is the responsibility of the buyer, and how they are used cannot be the liability of Limatorque. However, Limatorque's sales team and application engineers are always available to assist you in making your decision.

This manual contains information that is correct to the best of Limatorque's knowledge. It is intended to be a guide and should not be considered as a sole source of technical instruction, replacing good technical judgment, since all possible situations cannot be anticipated. If there is any doubt as to exact installation, configuration, and/or use, call Limatorque at (434) 528-4400. The latest revisions to this document are available at www.flowserve.com.

Contents

1 Introduction	5
1.1 Purpose	5
1.2 How to Use This Manual	5
1.3 User Safety	5
1.4 User Knowledge	6
1.5 DDC-100 System Capabilities and Features	6
1.6 General Specification	7
2 System Components	8
2.1 Introduction	8
2.2 Hardware	8
2.2.1 Limitorque Actuator	9
2.2.2 DDC–100 Field Unit	9
2.2.3 RS-485 to Ethernet Adapter	10
2.2.4 Host Controller	11
2.2.5 Master Station	12
2.2.6 Network Cable	13
2.3 Software	14
2.3.1 Modbus Protocol	14
2.3.2 Modbus Function Codes	15
2.3.3 Modbus Function Code 01 (Read Coil Status)	15
2.3.4 Modbus Function Code 02 (Read Input Status)	16
2.3.5 Modbus Function Code 03 (Read Holding Register)	18
2.3.6 Modbus Function Code 04 (Read Input Register)	22
2.3.7 Modbus Function Code 05 (Force Single Coil)	23
2.3.8 Modbus Function Code 06 (Preset Single Register)	24
2.3.9 Modbus Function Code 07 (Read Exception Status)	27
2.3.10 Modbus Function Code 08 (Diagnostics)	28
2.3.11 Modbus Function Code 15 (Force Multiple Coils)	29
2.3.12 Modbus Function Code 16 (Preset Multiple Registers)	30
2.3.13 Modbus Function Code 17 (Report Server ID)	31
2.3.14 Modbus Function Code 23 (Read/Write Multiple Registers)	33
3 Installation and Configuration	34
3.1 Site and Network Cable Preparation	34
3.1.1 Site Preparation	34
3.1.2 Network Cable Preparation	34
3.2 Installation Verification	44
3.2.1 Network Cabling Installation Verification	44
3.2.2 RS-485 to Ethernet Adapter Installation Verification	44
3.2.3 Field Unit Installation Verification	44
3.3 Field Unit Configuration	45
3.3.1 Configuring Field Unit Parameters	45
3.3.2 Configuring RS-485 to Ethernet Adapter Parameters	52
3.4 Configuration Confirmation	54
3.4.1 Checking Connections	54
3.4.2 View Settings	54
3.4.3 Checking the Normal Display	54
4 Associated Documents	55
5 Troubleshooting	56
6 How to Order Parts	58
Appendix A – Wiring Diagram	59
Appendix B – DDC Register Definitions	62
Appendix C – Device Identification Data	68
Appendix D – Typical DDC-100 Network Installation Assignments	71

Figures

Figure 1.1 – Typical DDC-100 system with or without a Master Station	6
Figure 2.1 – MX-05 actuator	8
Figure 2.2 - QX-1 actuator	9
Figure 2.3 - DDC-100 field unit	10
Figure 2.4 - RS-485 to Ethernet Adapter	10
Figure 2.5 - Typical direct-to-host arrangement	11
Figure 2.6 - Typical Master Station (rear view)	12
Figure 2.7 - Connection in redundant host loop topology	13
Figure 3.1 – RS-485 Network Connections	34
Figure 3.2 - Ethernet Network Connections	35
Figure 3.3 - Removing outer plastic jacket	35
Figure 3.4 - Separating cable parts	36
Figure 3.5 - Stripping conductors	36
Figure 3.6 - Applying heat shrink tubing	37
Figure 3.7 - Ring tongue connectors	37
Figure 3.8 - Connecting network cable to terminal block	38
Figure 3.9 - Redundant bi-directional loop topology	40
Figure 3.10 - Daisy chain topology	41
Figure 3.11 - Gateway configuration of RS-485 to Ethernet adapter	42
Figure 3.12 - Slave configuration of RS-485 to Ethernet adapter	43
Figure 3.13 - Jumper on RS-485 to Ethernet adapter	52
Figure 3.14 - Web interface login	52
Figure 3.15 - Web interface home screen	53
Figure 3.16 - Web interface Serial Settings setup	53
Figure 3.17 - Web interface Network setup	53
Figure 3.18 - Web interface Apply Settings	53
Figure 3.19 - Error messages	54
Figure A.1 (1 of 2) – Typical DDC-100 wiring diagram	59
Figure A.1 (2 of 2) – Typical DDC-100 wiring diagram	60
Figure A.2 - Terminal block	60

Tables

Table 2.1 – Modbus function codes supported	15
Table 2.2 – Coil Definitions	15
Table 2.3 – Status Bit Definitions	16
Table 2.3 – Status Bit Definitions (continued)	16
Table 2.4 – Register Definitions	19
Table 2.4 – Register Definitions (continued)	20
Table 2.4 – Register Definitions (continued)	21
Table 2.5 – DDC-100 coil assignments, Modbus 05 command usage for digital outputs	23
Table 2.6 – Register Commands	25
Table 2.7 – Diagnostic Codes	29
Table 3.3 – Network cable terminations	38
Table 3.4 – DDC digital input configurations (only one selection per row is permitted)	50
Table 3.5 – DDC digital inputs (cross-reference of various inputs)	50
Table 3.6 – Digital input voltages	50
Table 3.7 – DDC digital outputs S1-2 and R1-8	51

1 Introduction

1.1 Purpose

This manual explains how to install and operate the Flowserve Limitorque MX™/DDC-100 field unit and is to be used as an addendum to Bulletin FCD LMENIM2306, MX Electronic Actuator Installation and Operation Manual. Up to 250 actuators, each containing a DDC-100 field unit, may be connected by a single twisted-pair cable to form a DDC-100 network. This network permits the actuators to be operated by various control room devices such as a distributed control system (DCS), a programmable logic controller (PLC), or a personal computer (PC). The DDC-100 system communicates status and alarm data from each MX and valve.

1.2 How to Use this Manual

Each section provides the MX user with information on installing and operating the MX field unit.

Section 1 - Introduction

Details user safety and knowledge requirements, system capabilities, and features.

Section 2 - System Components

Focuses on the description of the DDC-100 system hardware and software components.

Section 3 - Installation and Configuration

Provides details for installing and configuring a field unit.

Section 4 - Associated Documents

Provides a list of documents on related subjects for additional DDC-100 system information.

Section 5 - Troubleshooting

Provides a set of procedures for troubleshooting operational issues.

Section 6 - How to Order Parts

Details process for ordering replacement parts.

Appendix A - Wiring Diagram

Details wiring connections.

Appendix B - DDC Register Definitions

Provides complete details regarding Modbus register contents.

Appendix C - Device Identification Data

Provides complete details regarding Report Server ID (FC 17) response frames.

Appendix D - Typical DDC-100 Network Installation Assignments

Details tasks and responsibilities involved with commissioning Limitorque DDC-100 field units.

1.3 User Safety

Safety notices in this manual detail precautions the user must take to reduce the risk of personal injury and damage to the equipment. The user must read and be familiar with these instructions before attempting installation, operation, or maintenance. Failure to observe these precautions could result in serious bodily injury, damage to the equipment, warranty void, or operational difficulty. User must follow local and state safety regulations.

Safety notices are presented in this manual in three forms:

 **WARNING:** Refers to personal safety. Alerts the user to potential danger. Failure to follow warning notices could result in personal injury or death.

 **CAUTION:** Directs the user's attention to general precautions that, if not followed, could result in personal injury and/or equipment damage.

NOTE: Highlights information critical to the user's understanding of the operator's installation and operation.

1.4 User Knowledge

It is recommended that the user read this manual in its entirety before the DDC-100 equipped actuator is installed and operated.

The user needs to have a fundamental knowledge of electronics and microprocessor concepts. An understanding of valve actuators and digital control systems is beneficial to the field unit user.

1.5 DDC-100 System Capabilities and Features

Limitorque's distributed digital control (DDC) valve control network supports up to 250 actuators over a single twisted-pair cable using Modbus™ protocol. MX actuators and other devices can be accessed from a control room for integration with a plant asset management (PAM) system, distributed control system (DCS), programmable logic controller (PLC), or personal computer (PC) based network. The DDC-100 system consists of a host system, controller, network, and field units. A typical DDC-100 system is shown in **Figure 1.1**.

Figure 1.1 – Typical DDC-100 system with or without a Master Station

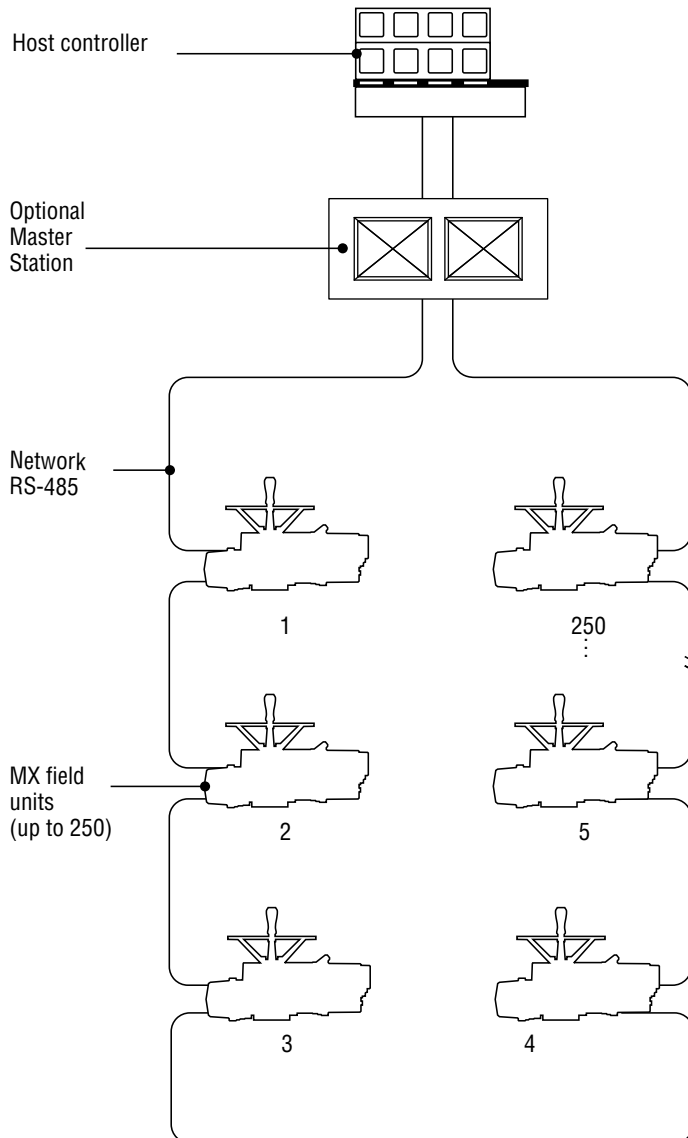

1.6 General Specifications

- **Direct-to-Host Specifications:**

- Direct connection to host controller
- Communicates using the Modbus protocol and RS-485 or Ethernet electrical standards
- Configurable bitmap
- High-level surge protection on network

- **Network Specifications:**

- Redundant bi-directional loop or daisy chain topology
- Modbus protocol over RS-485 or Ethernet
- High speed—up to 38.4 kbaud communications

- **Field Unit Specifications:**

- Accepts various movement commands (OPEN, STOP, CLOSE, MOVE-TO)
- Supports Emergency Shutdown (ESD) operations
- Actuator status and alarm messages
- Six digital inputs and two analog inputs for user (see **Table 2.2, Register Definitions**)
- Two surge-protected and mutually isolated communication channels
- Local control panel configuration
- Torque output (for reference only) and position feedback
- User's analog input feedback
- Nine digital outputs maximum (three standard/six optional)

- **Master Station (Optional) Specifications:**

- Supports all Limatorque DDC-100 field units (MX, L120, LY, QX, QXM, UEX)
- Monitors and controls up to 250 MOVs
- User-friendly touch panel operator interface:
 - Permits configuration and control of DDC-100 network
 - Configures communication to host or DCS (Distribution Control System)
 - Password protected
- Optional Hot Standby configuration:
 - Automatically assumes control on Primary Master Failure or on command from the DCS or touch panel
- Provides status of field units through continuous cyclical polling
- Modbus RTU and TCP/IP:
 - Addressable
 - RS-232/485/422
 - 10/100 baseT
- Built-in Web server for easy access to actuator and network diagnostics

2 System Components

2.1 Introduction

This section gives an overview of the components used in the DDC-100 system. The field unit is installed in each MX actuator. The network cable connects the field unit to the network via the actuator terminal block. The network cable is connected to a host controller or Master Station.

2.2 Hardware

NOTE: Recommended storage procedures are detailed in the Maintenance and Spare Parts Manuals. Failure to comply with recommended procedures will void the warranty. For longer-term storage, contact Flowserve for procedures and recommendations.

Figure 2.1 – MX-05 actuator

Piece	Description
1	Handwheel
2	Declutch Lever
3	Oil Fills (dotted arrow depicts fill on declutch side)
4	Controls Compartment (field unit location)
5	LCD Display
6	Control Knobs
7	Ground Lug
8	Thrust/Torque Base
9	Conduit Entries
10	Terminal Compartment
11	Motor
12	Nameplate

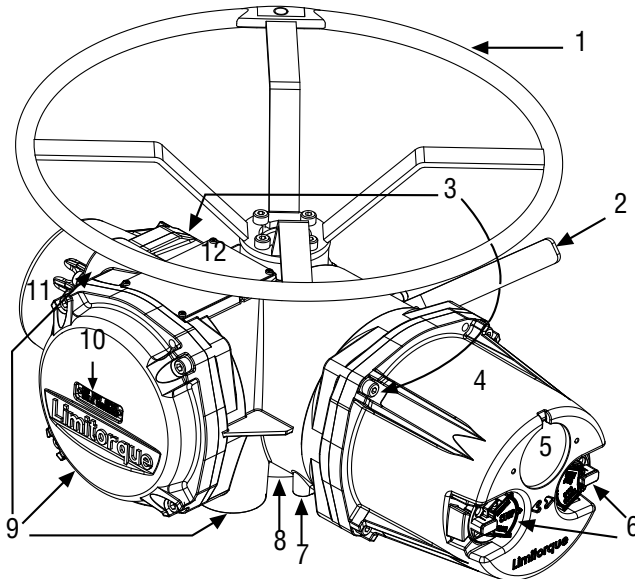
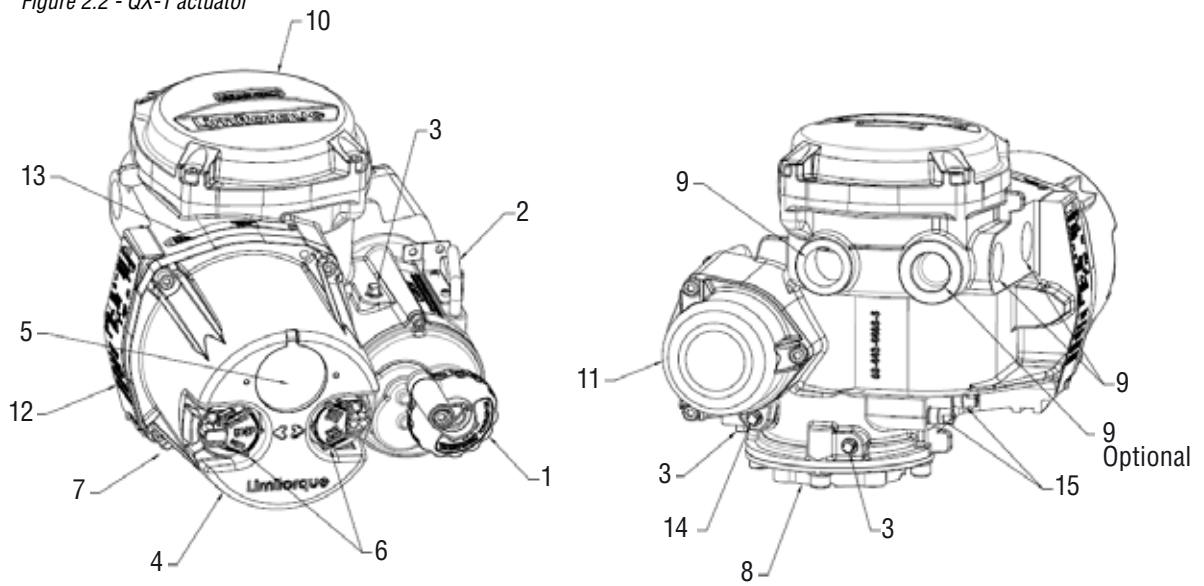

Figure 2.2 - QX-1 actuator



Piece	Description
1	Handwheel
2	Declutch lever (QX-05)
3	Oil fill
4	Controls cover
5	LCD

Piece	Description
6	Control knob
7	Ground lug
8	Baseplate
9	Conduit entry
10	Terminal compartment

Piece	Description
11	Motor
12	Certification nameplate
13	Tag nameplate
14	Oil plug
15	Stem stop nuts

2.2.1 Limatorque Actuator

There are several types of Limatorque actuators designed for operation of ON-OFF and modulating valve applications. The MX, MXa, QXM and UEX are multi-turn valve actuators; the QX is a quarter-turn (90 degree) valve actuator. These actuators control the opening and closing of valves. See **Figure 2.1**.

The common features of these actuators include:

- Non-intrusive setup
- Separately sealed terminal chamber
- Absolute encoder for valve position sensing (no battery required)
- 32-character graphical LCD display with 180° rotation
- Sophisticated electronic control, monitoring, and diagnostic capabilities with LimiGard™ technology

2.2.2 DDC–100 Field Unit

The DDC-100 field unit is installed in the actuator controls compartment. This unit permits the actuator to be controlled by a host controller or Master Station via the DDC-100 network. The field unit includes two high-level, surge-protected, and isolated network communication channels, configurable digital I/O, and configuration via LCD screen. The following commands and information may be transmitted over the DDC-100 network:

- OPEN, STOP, and CLOSE commands
- ESD and MOVE-TO position commands
- Actuator status and alarm messages
- Six digital inputs and two analog inputs for user (see **Table 2.2, Register Definitions**)
- Torque output (for reference only) and position feedback
- User's analog input feedback
- Nine digital outputs maximum (three standard/six optional)
- In-depth device identification information

Figure 2.3 - DDC -100 field unit

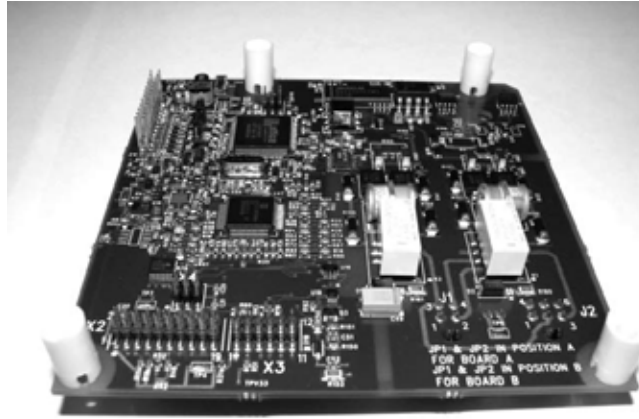

2.2.3 RS-485 to Ethernet Adapter

If the host controller intends to use Modbus TCP/IP for communication with field units a RS-485 to Ethernet adapter may be used in conjunction with Limitorque actuators to handle the physical layer translation.

Figure 2.4 - RS-485 to Ethernet adapter



The RS-485 to Ethernet adapter can be configured to support a variety of network arrangements. The topology of the user's Modbus network will determine how the adapter is deployed. The two most common uses are:

Gateway Device

- Serves as an interface between an Ethernet segment and RS-485 segment of the Modbus network.
- Useful for Modbus networks that still depend on RS-485 cabling.
- Can manage communications for multiple actuators (1 to 250 field units).

Slave Device

- Serves as an interface between an Ethernet segment and a single Limitorque actuator.
- Useful for Modbus networks that operate exclusively on Ethernet cabling.
- Is mounted inside the terminal block compartment of the Limitorque actuator.

The RS-485 to Ethernet adapter requires 24VDC power to operate. This power can be obtained from the Limitorque actuator (24VDC output) or provided by user equipment.

2.2.4 Host Controller

In the DDC-100 system, the network can be connected directly to a host controller without an interposing Master Station.

In this configuration, the host sends commands and messages directly to/from the field units. The gathered responses are stored in a data table in the host and are periodically updated by sequential polling of the field units. The host controls up to 250 field units. See **Section 3.1.2.2, Network Cable Connection to Host System or Master Station** for details regarding network wiring.

When a host controller is used to directly communicate with the field units (i.e., direct-to-host) it communicates using the Modbus protocol and either the RS-485 or Ethernet electrical standard. This host controller can be one of the following:

- Distributed control system (DCS)
- Programmable logic controller (PLC)
- Personal computer (PC)
- Plant Asset Management (PAM) system

Figure 2.5 – Typical direct-to-host arrangement

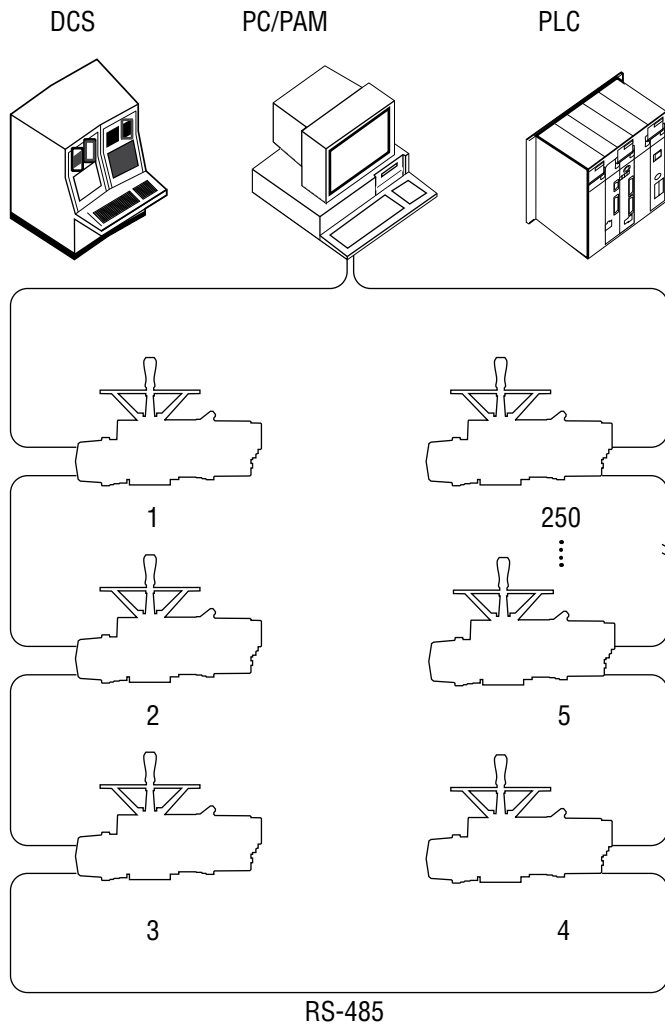

2.2.5 Master Station

A Master Station may be used in the DDC-100 system. Master Station's are normally located in the control room, and serve as the interface between the field units and the host controller. The following functions are provided:

- Continuous polling of actuator network
- Message routing to/from field units
- Data concentration
- Data logging

In this configuration, the Master Station receives commands from a host controller. The Master Station communicates with the host controller using the Modbus Protocol and either the RS-232/422/485 or Ethernet electrical standard. See **Bulletin FCD LMENIM5001, Master Station Installation and Operation Manual** for details regarding host communication with the Master Station.

The Master Station sends commands and messages to, and gathers responses from, the field units. The gathered responses are stored in a poll table in the Master Station and are periodically updated by sequential polling of the field units. The Master Station monitors and controls up to 250 field units. See **Section 3.1.2.2, Network Cable Connection to Host System or Master Station** for details regarding network wiring.

Figure 2.6 – Typical Master Station (rear view)

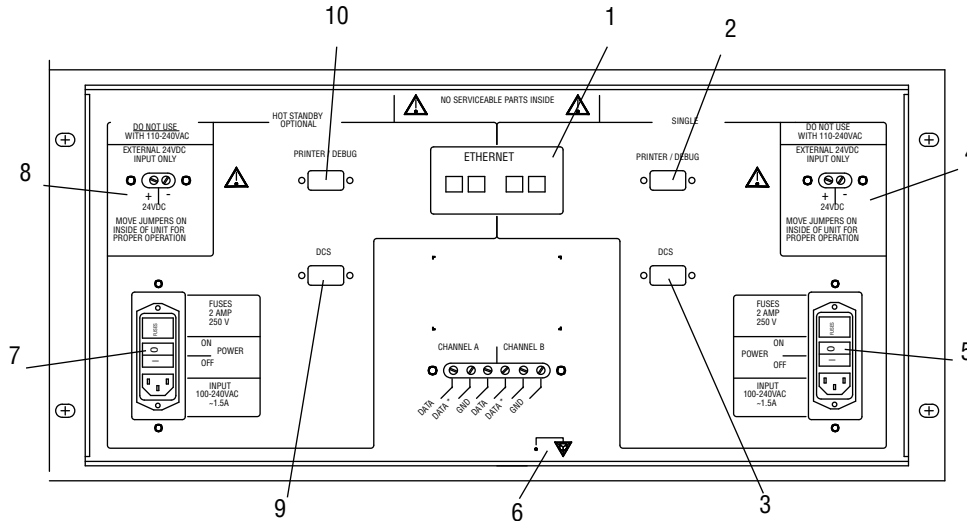

1. Ethernet ports
2. Printer/Debug port
3. DCS port
4. Auxiliary 24 VDC power connection
5. Main power switch and connector for 120-240 VAC
6. Electrostatic ground
7. Hot Standby unit main power switch and connector for 120-240 VAC
8. Hot Standby auxiliary 24 VDC power connection
9. Hot Standby DCS Port
10. Hot Standby Printer/Debug Port

2.2.6 Network Cable

The network consists of shielded cable that connects all field units and the host/Master Station. For RS-485 networks the cable is normally connected in a loop fashion so that any single break or short will not disable communication.

Figure 2.7 – Connection in redundant host loop topology

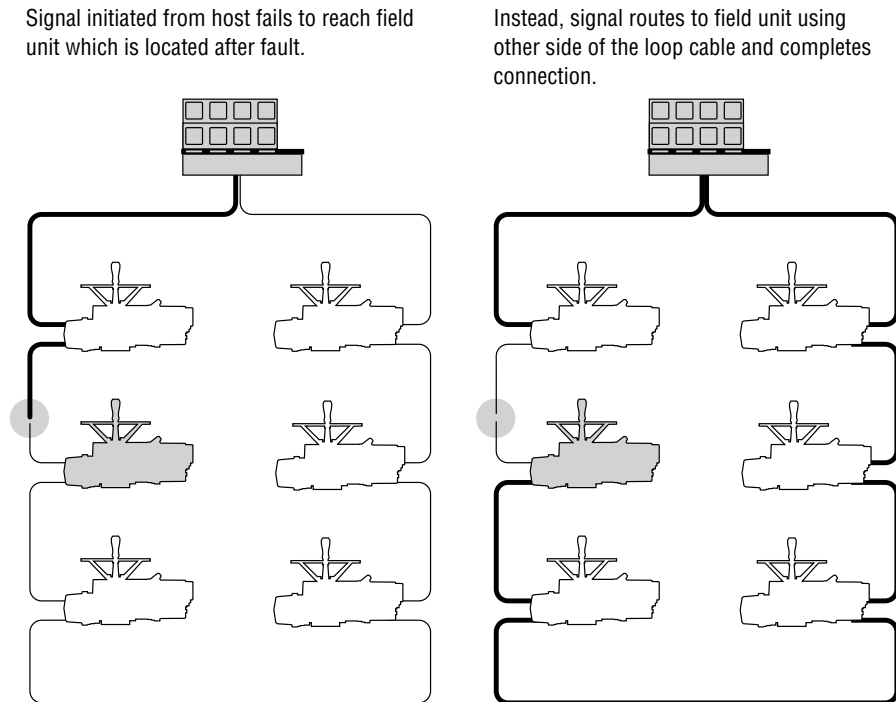

The network cable connects the field units to the host controller or Master Station. Belden 3074F, 3105A, or 9841 shielded, twisted-pair cable should be used for RS-485 wiring. Belden CAT5e shielded cable should be used for Ethernet wiring. The use of other cables may result in a reduction of internodal distances or increased error rate, and is the user's responsibility.

Belden 3074F Specifications

- Total cable length between repeaters or nodes with repeaters, up to 38.4 kbps: 5000 ft (1.52 km) For loop mode, this is the total length between operating field units. If a field unit loses power, then the relays internal to the field unit connect the A1 Channel to the A2 Channel, which effectively doubles the length of the cable (assuming a single field unit fails). To ensure operation within specifications in the event of power failure to field units, this consideration must be added. **Example:** To ensure operation within specification when any two consecutive field units lose power, the maximum length of cable, up to 38.4 kbps, should not exceed 5000 ft (1.52 km) per every four field units. See **Section 3.1.2.2, Network Cable Connection to Host Controller or Master Station** for details regarding network wiring.

Key Specifications

- Resistance/1000 ft = 18 AWG (7 x 26) 6.92 ohms each conductor (13.84 ohms for the pair)
- Capacitance/ft = 14 pF (conductor-to-conductor)
- Capacitance/ft = 14 pF (conductor-to-shield)

Belden 3105A Specifications

- Total cable length between repeaters or nodes with repeaters, up to 38.4 kbps: 4500 ft (1.37 km) For loop mode, this is the total length between operating field units. If a field unit loses power, then the relays internal to the field unit connect the A1 Channel to the A2 Channel, which effectively doubles the length of the cable (assuming a single field unit fails). To ensure operation within specifications in the event of power failure to field units, this consideration must be added. **Example:** To ensure operation within specification when any two consecutive field units lose power, the maximum length of cable, up to 38.4 kbps, should not exceed 4500 ft (1.37 km) per every four field units. See **Section 3.1.2.2, Network Cable Connection to Host Controller or Master Station** for details regarding network wiring.
 - Resistance/1000 ft = 22 AWG (7 x 30) 14.7 ohms each conductor (29.4 ohms for the pair)
 - Capacitance/ft = 11.0 pF (conductor-to-conductor)
 - Capacitance/ft = 20.0 pF (conductor-to-shield)

Belden 9841 Specifications

- Total cable length between repeaters or nodes with repeaters: up to 38.4 kbps: 3500 ft (1 km) For loop mode, this is the total length between operating field units. If a field unit loses power, then the relays internal to the field unit connect the A1 Channel to the A2 Channel, which effectively doubles the length of the cable (assuming a single field unit fails). To ensure operation within specifications in the event of power failure to field units, this consideration must be added. **Example:** To ensure operation within specification when any two consecutive field units lose power, the maximum length of cable, up to 38.4 kbps, should not exceed 3500 ft (1 km) per every four field units. See **Section 3.1.2.2, Network Cable Connection to Host Controller or Master Station** for details regarding network wiring.

Key Specifications

- Resistance/1000 ft = 24 AWG (7 x 32) 24 ohms each conductor (48 ohms for the pair)
- Capacitance/ft = 12.8 pF (conductor-to-conductor)
- Capacitance/ft = 23 pF (conductor-to-shield)

2.3 Software

2.3.1 Modbus Protocol

The Modbus protocol was developed by AEG Modicon® for communicating to various networked devices. The relationship between these devices and a central controller is called a master-slave relationship in which the master (host device) initiates all communication. The slave devices (DDC-100 field units in the actuators) respond to the queries from the master.

Modbus only permits one device to communicate at any given time (simultaneous communication is prohibited) to ensure process control integrity.

2.3.2 Modbus Function Codes

The controlling device (master) must conform to the Modbus protocol as defined in the Modbus-IDA Modbus Application Protocol Specification V1.1b3 (<http://www.Modbus-IDA.org>) . Flowserve actuators support the use of Modbus function codes 01 through 08, 15 through 17, and 23. These function codes are a subset of the complete protocol and are defined in **Table 2.1**.

Table 2.1 – Modbus function codes supported

Function Code	Name	Extended Bit/Register Addressing	Addressing Range
01	Read Coil Status	Bit	0,000 - 9,999
02	Read Discrete Inputs	Bit	10,000 - 19,999
03	Read Holding Register	Register	40,000 - 49,999
04	Read Input Register	Register	30,000 - 39,999
05	Force Single Coil	Bit	0,000 - 9,999
06	Preset Single Register	Register	40,000 - 49,999
07	Read Input Register	N/A	N/A
08	Diagnostics	N/A	N/A
15	Force Multiple Coils	Bit	0,000-9,999
16	Preset Multiple Registers	Register	40,000 - 49,999
17	Report Server ID	N/A	N/A
23	Read/Write Multiple Registers	Register	40,000 - 49,999

See Table 2.2 for a complete listing of DDC holding registers.

2.3.3 Modbus Function Code 01 (Read Coil Status)

This function code is used to read the coil status in the DDC-100 Field Unit. There are nine coils available to be read on DDC-100 Field Units as shown in **Table 2.2**. Coil 1 indicates CLOSE contactor and is interlocked with Coil 2, Coil 2 indicates OPEN contactor and is interlocked with Coil 1. When the I/O Module is used in non-MOV (motor-operated valve) mode, relays 1 through 6 or coils 3 through 8 are available for user configuration.

Table 2.2 – Coil Definitions

Coil Number	Bit Number	Function
1	00	Close/Stop
2	01	Open/Stop
3	02	S1 or R1 (Opt) Latched
4	03	S2 or R2 (Opt) Latched
5	04	R3 (Opt) Latched
6	05	R4 (Opt) Latched
7	06	R5 (Opt) Latched
8	07	R6 (Opt) Latched
9	08	R7 (Opt) Latched
10	09	R8 (Opt) Latched

Example

Poll field unit number 3 for 8 coils starting at coil 1.

Query: 0301000000083C2E

Response: 03010118503A

Message Breakdown

Query		Response	
03	Slave (Field Unit) Address	03	Slave (Field Unit) Address
01	Function	01	Function
00	Starting Address Hi	01	Byte Count
00	Starting Address Lo	18 ¹	Data (Coils 8 - 1)
00	No. of Points Hi	503A	Error Check (CRC)
08	No. of Points Lo		
3C2E	Error Check (CRC)		

Note 1: 18h equals 00011000 or coils 4 and 5 are ON.

2.3.4 Modbus Function Code 02 (Read Input Status)

This function code is used to read the discrete input status bits in the DDC-100 Field Unit. The use of this function code will provide the user with the input status bits that are used to develop holding registers 9 through 13. The status bit inputs are contained in locations 10129-10208 for each DDC-100 Field Unit and are defined in **Table 2.3**.

Table 2.3 – Status Bit Definitions

Bit Number	Modbus Bit Address	Bit Definition
129	128	Opened
130	129	Closed
131	130	Stopped in mid-travel
132	131	Opening
133	132	Closing
134	133	Valve jammed
135	134	Not in remote
136	135	Combined fault
137	136	Over-temperature fault
138	137	Knob in stop
139	138	Channel A fault
140	139	Channel B fault
141	140	Open torque switch fault
142	141	Close torque switch fault
143	142	Valve operated manually fault
144	143	Phase error
145	144	Open inhibit active
146	145	Close inhibit active
147	146	Not used
148	147	Not used
149	148	One or more phases is missing
150	149	Reverse phase sequence is occurring
151	150	ESD conflict
152	151	Inhibit conflict
153	152	Use in local/stop (input must be set for CSE and enabled)
154	153	Not used
155	154	Network emergency shutdown (ESD) is active
156	155	Local emergency shutdown is active

Table 2.3 – Status Bit Definitions (continued)

Bit Number	Modbus Bit Address	Bit Definition
157	156	Field unit microprocessor has reset since the last poll
158	157	In stop mode
159	158	Opening in local mode
160	159	Closing in local mode
161	160	Close contactor (interlocked)
162	161	Open contactor (interlocked)
163	162	S1 or R1 (opt)
164	163	S2 or R2 (opt)
165	164	R3 (opt)
166	165	R4 (opt)
167	166	R5 (opt)
168	167	R6 (opt)
169	168	R7 (opt)
170	169	Network relay
171	170	R8 (opt)
172	171	Not used
173-176	172-175	Mov series (0=UEC, 1=MX, 6=QX, 9=MXa, 10=UEX, 11=QXM)
177	176	Knob in remote
178	177	Thermal overload
179	178	Open torque switch
180	179	Open limit switch
181	180	Close torque switch
182	181	Close limit switch
183	182	Analog Input #2 lost
184	183	Quikpower board present
185	184	User Input 0
186	185	User Input 1
187	186	User Input 2
188	187	Remote stop input
189	188	Remote open input
190	189	Remote close input
191	190	User Input 6
192	191	User Input 7
193	192	Analog board 1 present
194	193	Analog board 2 present
195	194	Analog Input #0 lost
196	195	Analog Input #1 lost
197	196	Network Channels A & B timed out
198	197	Relay board R5-R8 present
199	198	DDC board present
200	199	Relay board R1-R4 and RM present
201	200	FF board present
202	201	PB PA board present
203	202	CSE assigned to User Input 2
204	203	DNET board present

Table 2.3 – Status Bit Definitions (continued)

Bit Number	Modbus Bit Address	Bit Definition
205	204	Lost phase
206	205	Reverse phase
207	206	User Input 8
208	207	PB DP board present

Example

Poll field unit number 22 for 16 inputs starting at input 129 with the actuator opening.

Query: 1602008000107B09

Response: 1602020108CDED

Message Breakdown

Query		Response	
16	Slave (Field Unit) Address	16	Slave (Field Unit) Address
02	Function	02	Function
00	Starting Address Hi	02	Byte Count
80	Starting Address Lo	01 ¹	Data (Inputs 10136 - 10129)
00	No. of Points Hi	08 ²	Data (Inputs 10144 - 10137)
10	No. of Points Lo	CDED	Error Check (CRC)
7B09	Error Check (CRC)		

Note 1: 01h equals 0000 0001 (actuator open input bit is ON).

Note 2: 08h equals 0000 1000 (actuator Channel B Fail bit is ON).

2.3.5 Modbus Function Code 03 (Read Holding Register)

This function code is used to read the contents of holding registers in the DDC-100 Field Unit. This function code is typically used during the network polling cycle. A network poll should consist of field unit registers 9 (Status) and 10 (Fault) at a minimum. Holding register 8 (Position) should also be polled when the actuator is configured for the analog feedback option or position control. See **Table 2.4** for a complete listing of the holding registers.

Table 2.4 – Register Definitions

Register #	Description	Meaning
1	Command	Command Value (Write-Only)
2	Argument	Argument Value (Write-Only)
3	Analog Output 1	Analog Output 1 Value (Default 0-100) ¹
4	Analog Output 2	Analog Output 2 Value (Default 0-100) ¹
5	Analog Input	Main Power (Volts)
6	Analog Input	Analog Input 1 Value (Default 0-100) ¹
7	Analog Input	Analog Input 2 Value (Default 0-100) ¹
8	Position	Valve Position, (Default 0-100) ¹
9	Status Register	16 Bits of field unit status: Bit 0 Opened Bit 1 Closed Bit 2 Stopped in Mid-Travel Bit 3 Opening Bit 4 Closing Bit 5 Valve jammed Bit 6 Not in Remote ² Bit 7 Combined fault ³ Bit 8 Over temperature fault Bit 9 Knob in Stop Bit 10 Network Channel A fault ⁴ (Terminals 5 and 4) Bit 11 Network Channel B fault ⁴ (Terminals 13 and 14) Bit 12 Open torque switch fault Bit 13 Close torque switch fault Bit 14 Valve operated manually Bit 15 Phase error

NOTE 1: Default value is scaled 0-100 of span. Changes made to “Analog Scale” affect analog registers (3, 4, 6, 7, 8, 15) and “move-to” commands. (0-100, 0-255, 0-4095).

NOTE 2: DDC actuators shipped after 2nd QTR, 1999, have the following definition of Register 9 Bit 6. When this bit has a value of 1 or true, the actuator is in LOCAL or STOP (unavailable for network control). The actuator selector switch in REMOTE (available for network control) is indicated by Register 12 Bit 0 having a value of 1 or true.

IMPORTANT: Verify host program when installing an DDC actuator shipped after 2nd QTR, 1999, on a network commissioned before 2nd QTR, 1999, for proper indication of selector switch values. Failure to verify proper selector switch indication at the host may cause unsafe conditions at the facility.

DDC actuators shipped prior to 2nd QTR, 1999, have the following definition for Register 9 Bit 6. When this bit has a value of 1 or true, the actuator selector switch is in LOCAL mode. This bit does not indicate STOP or REMOTE. The actuator selector switch in REMOTE (available for network control) is indicated by Register 12 Bit 0 having a value of 1 or true. Register 9 Bit 6 value 0 (zero) or false AND Register 12 Bit 0 value 0 (zero) or false indicates selector switch is in the STOP position.

NOTE 3: Combined Fault bit is high when Bit 5 or 8 or 9 or 15 or (Bits 10 and 11) is high.

NOTE 4: Channel A is physical connection A1. Channel B is physical connection A2. (See **Appendix A.**)

Table 2.4 – Register Definitions (continued)

Register #	Description	Meaning
10	Fault Register	Value of 16 Fault Indications Bit 0 Open inhibit active Bit 1 Close inhibit active Bit 2 Not Used Bit 3 Not Used Bit 4 One or more phases are missing Bit 5 Reverse phase sequence is occurring Bit 6 ESD conflict Bit 7 Inhibit conflict Bit 8 CSE in local/stop (input must be set for CSE and enabled) Bit 9 Not Used Bit 10 Network emergency shutdown is active Bit 11 Local emergency shutdown is active Bit 12 Field unit microprocessor has reset since the last poll Bit 13 In stop mode Bit 14 Opening in local mode Bit 15 Closing in local mode
11	Digital Outputs	Value of 16 Digital Outputs Bit 0 Close contactor (Interlocked) Bit 1 Open contactor (Interlocked) Bit 2 S1 or R1 (Opt) Bit 3 S2 or R2 (Opt) Bit 4 R3 (Opt) Bit 5 R4 (Opt) Bit 6 R5 (Opt) Bit 7 R6 (Opt) Bit 8 R7 (Opt) Bit 9 Network Relay Bit 10 R8 (Opt) Bit 11 Not Used Bit 12-15 MOV Series (0=UEC, 1=MX, 6=QX, 9=MXa, 10=UEX, 11=QXM)
12	Digital Inputs 1	Value of 16 Digital Inputs Bit 0 Knob in Remote Bit 1 Thermal Overload Bit 2 Open Torque Switch Bit 3 Open Limit Switch Bit 4 Close Torque Switch Bit 5 Close Limit Switch Bit 6 Analog Input 2 lost Bit 7 Quik board present Bit 8 User Input 0 (Default=ESD), Terminal 30 Bit 9 User Input 1 (Default=Open Inhibit), Terminal 34 Bit 10 User Input 2 (Default=Close Inhibit), Terminal 35 Bit 11 Remote Stop Input, Terminal 26 Bit 12 Remote Open Input, Terminal 25 Bit 13 Remote Close Input, Terminal 27 Bit 14 User Input 6 Bit 15 User Input 7

Table 2.4 – Register Definitions (continued)

Register #	Description	Meaning
13	Digital Inputs 2	Value of 16 Digital Inputs Bit 0 Analog board 1 present Bit 1 Analog board 2 present Bit 2 Analog Input 0 lost Bit 3 Analog Input 1 lost Bit 4 Network Channels A & B timed out Bit 5 Relay board R5-R8 present Bit 6 DDC board present Bit 7 Relay board R1-R4 and RM present Bit 8 Foundation Fieldbus board present Bit 9 Profibus PA board present Bit 10 CSE chosen for User Input 2 Bit 11 DeviceNet board present Bit 12 Phase lost Bit 13 Phase reverse Bit 14 User Input 8 Bit 15 Profibus DP board present
14	Timers and Analog Channels	Internal compartment temperature ⁵
15	Torque	Actuator Torque (Default=0-100) ¹
16	Current State	Bits 0-15 Not Used
17	Field Unit Holding Register	Special Applications Only
18	Field Unit Holding Register	Special Applications Only
19	Field Unit Holding Register	Special Applications Only
20	Field Unit Holding Register	Special Applications Only
21	Field Unit Holding Register	Special Applications Only
22	Field Unit Holding Register	Special Applications Only
23	Field Unit Holding Register	Special Applications Only
24-44	Reserved	Special Applications Only
45-47	Not Named	Special Applications Only
48	TP_START_POSITION	Special Applications Only
49	TP_STOP_POSITION	Special Applications Only
50	TP_SAMPLE	Special Applications Only
51	TP_MID_T_HIGH	Special Torque Applications Only
52	TP_MID_T_POS	Special Applications Only
53	TP_MID_T_AV_VAL	Special Torque Applications Only
54	TP_STOP_VAL	Special Applications Only
55	TP_BEFORE_MID_T_HIGH	Special Torque Applications Only
56	TP_AFTER_MID_T_HIGH	Special Torque Applications Only

NOTE 5: Range is +90°C to -55°C. High byte 00 indicates positive (+) and 01 indicates negative (-). Low byte indicates temperature value.

Example: 0x0019 = +25°C

0x011E = -30°C

Example

Poll field unit number 125 for 3 registers starting at register 8 with the actuator stopped between the limits and in local mode.

Query: 7D0300070003BFF6

Response: 7D0306003D084400003E07

Message Breakdown

Query		Response	
7D	Slave (Field Unit) Address	7D	Slave (Field Unit) Address
03	Function	03	Function
00	Starting Address Hi	06	Byte Count
07	Starting Address Lo	00	Data Hi (Register 40008)
00	No. of Points Hi	3D ¹	Data Lo (Register 40008)
03	No. of Points Lo	08	Data Hi (Register 40009)
BFF6	Error Check (CRC)	44 ²	Data Lo (Register 40009)
		00	Data Hi (Register 40010)
		00	Data Lo (Register 40010)
		3E07	Error Check (CRC)

Note 1: 003Dh equals 61 Decimal (actuator Analog Input 1 in percent format).

Note 2: 0844h equals 2116 Decimal or 0000 1000 0100 0100 Binary (actuator stopped between limits, local mode, and Channel B Fail bit is ON).

2.3.6 Modbus Function Code 04 (Read Input Register)

This function code is used to read the contents of input registers in the DDC-100 Field Unit. The typical use of this function code is to read the analog input registers. If the field unit is configured for scaled analog data, the register information will be returned as a percent from 0 to 100 (see NOTE below). The first analog input register (Analog 4) will start at register 30005 through (Analog 1) 30008.

NOTE: Limitorque field units can be configured to report analog data in several formats. See the appropriate field unit manual for details.

Example

Poll field unit number 70 for 4 registers starting at register 5 (Analog Input Registers 1-4).

(This example assumes that the field unit is configured for scaled analog data.)

Query: 460400040004BF7F

Response: 460408FFFFFFFFF002B001EDBA8

Message Breakdown

Query		Response	
46	Slave (Field Unit) Address	46	Slave (Field Unit) Address
04	Function	04	Function
00	Starting Address Hi	08	Byte Count
04	Starting Address Lo	FF	Data Hi (Register 40005)
00	No. of Points Hi	FF ¹	Data Lo (Register 40005)
04	No. of Points Lo	FF	Data Hi (Register 40006)
BF7F	Error Check (CRC)	FF ²	Data Lo (Register 40006)
		00	Data Hi (Register 40007)
		2B ³	Data Lo (Register 40007)
		00	Data Hi (Register 40008)
		1E ⁴	Data Lo (Register 40008)
		DBA8	Error Check (CRC)

Note 1: FFFFh equals 65535 Decimal (actuator Analog Input 4 value).
Note 2: FFFFh equals 65535 Decimal (actuator Analog Input 3 value).
Note 3: 002Bh equals 43 Decimal (actuator Analog Input 2 value).
Note 4: 001Eh equals 30 Decimal (actuator Analog Input 1 in percent format).

2.3.7 Modbus Function Code 05 (Force Single Coil)

This function code is used to force a single coil in the DDC-100 Field Unit. Forcing the individual coil either ON (1) or OFF (0) will energize or de-energize a coil (digital output) in the field unit. Coil 1 in the field unit closes the actuator and Coil 2 opens the actuator. If the actuator is opening or closing, changing the status of coil 1 or 2 from a value of 1 to 0 will stop the actuator (the coil will automatically be set to zero when the actuator reaches the full open or full close position).

Available digital outputs for DDC-100 Field Units are listed in **Table 2.5**. Each command should be issued only once for the desired field unit control. Repeated issuance of an acknowledged command will degrade network performance. The normal response to the (05) command is an echo of the command.

NOTE: DDC-100 Field Unit relays must be configured for network control in order to perform a force coil command.

Table 2.5 – Coil Definitions

Coil Number	Bit Number	Function
1	00	Close/Stop
2	01	Open/Stop
3	02	S1 or R1 (Opt) Latched
4	03	S2 or R2 (Opt) Latched
5	04	R3 (Opt) Latched
6	05	R4 (Opt) Latched
7	06	R5 (Opt) Latched
8	07	R6 (Opt) Latched
9	08	R7 (Opt) Latched
10	09	R8 (Opt) Latched

Example

Force coil 1 of field unit 49 ON. This will CLOSE the valve controlled by field unit 49.

Query: 31050000FF0089CA

Response: 31050000FF0089CA

Message Breakdown

Query		Response	
31	Slave (Field Unit) Address	31	Slave (Field Unit) Address
05	Function	05	Function
00	Coil Address Hi	00	Coil Address Hi
00 ¹	Coil Address Lo	00	Coil Address Lo
FF	Force Data Hi	FF	Force Data Hi
00 ²	Force Data Lo	00	Force Data Lo
89CA	Error Check (CRC)	89CA	Error Check (CRC)

Note 1: 0000h equals Coil Address 00000001 (field unit coil 1).

Note 2: FF00h requests the coil to be ON (0000h requests the coil to be OFF).

2.3.8 Modbus Function Code 06 (Preset Single Register)

This function code is used to preset a single register in the field unit. The function code is typically used to command the DDC-100 Field Unit by writing values to registers 1 (Command) and 2 (Argument). Defined command values may be used to open/stop/close the actuator, move the actuator to a preset position, activate/deactivate network ESD, reset the field unit, etc.

Modbus FC 06 is also used to command a modulating actuator to “move-to” a position of 0-100% of open. The field unit will compare the new position value with the current position and open or close the valve to meet the new position requirement. This is a two-step command: the first step is to write the desired position value to the field unit register 2, then write the value of 6656 to field unit register 1. This sequence of commands loads the desired position, then instructs the field unit to execute the command. Alternatively, the “move-to” command may be executed with a one-step command.

Modbus FC 06 command values for controlling the DDC-100 Field Unit are given in **Table 2.6**. Each command should be issued only one time for the desired field unit control. Repeated issuance of an acknowledged command will degrade network performance. The normal response to the (06) command is an echo of the command.

NOTE:

- 1) Only use values listed in **Table 2.6** For field unit register 1 (Command).
- 2) Field unit register 2 (Argument) should only be used for “move-to” position input.
- 3) The Host MUST issue “move-to” commands in the proper sequence. Failure to issue this two-step command in the correct sequence will result in the field unit waiting for the proper command sequence execution before performing the “move-to” function.
- 4) The “move-to” command should only be used with field units that include the position control option.
- 5) Do not write to field unit registers 5-16.

Table 2.6 – Register Commands

Host Commands to Field Unit Register 1	Value (Decimal)	Function
Null Command	0	No action
Open	256	Open actuator
Stop	512	Stop actuator
Close	768	Close actuator
Reset Field Unit	1024	Reset processor
Start Network ESD	1280	ESD initiate
Stop Network ESD	1536	ESD terminate
Engage Relay #1	2304	S1 or R1 (opt)
Engage Relay #2	2560	S2 or R2 (opt)
Engage Relay #3	2816	R3 (opt)
Engage Relay #4	3072	R4 (opt)
Engage Relay #5	3328	R5 (opt)
Engage Relay #6	3584	R6 (opt)
Engage Relay #7	3840	R7 (opt)
Disengage Relay #1	4352	S1 or R1 (opt)
Disengage Relay #2	4608	S2 or R2 (opt)
Disengage Relay #3	4864	R3 (opt)
Disengage Relay #4	5120	R4 (opt)
Disengage Relay #5	5376	R5 (opt)
Disengage Relay #6	5632	R6 (opt)
Disengage Relay #7	5888	R7 (opt)
Move-To (Enable)1	6656	Initiates “move-to”
Engage Relay #8	6912	R8 (opt)
Disengage Relay #8	7168	R8 (opt)

Note 1: This is a two-step command. A valid value must be written to Register 2 before issuing this command. (See Note 1 of Table 2.2.)

Other registers may also be preset to control or change other functions but care must always be taken to properly change these values. An improper value written to a register can cause undesirable actions from the DDC-100 Field Unit.

Example of Field Unit Command

Write the command to open an actuator (actuator open) to field unit number 179. This corresponds to writing the value 256 into field unit register 1.

Query: B306000001009388

Response: B306000001009388

Message Breakdown

Query		Response	
B3	Slave (Field Unit) Address	B3	Slave (Field Unit) Address
06	Function	06	Function
00	Register Address Hi	00	Register Address Hi
00'	Register Address Lo	00	Register Address Lo
01	Force Data Hi	01	Preset Data Hi
00 ²	Force Data Lo	00	Preset Data Lo
9388	Error Check (CRC)	9388	Error Check (CRC)

Note 1: 0000h equals Register Address 40001 (field unit register 1, command register).

Note 2: 0100h requests the register to be preset with 256 Decimal (engage open contactor).

Example of “Move-To” Command

Move an actuator at address 179 to 42% of open by first writing the value of 42 to the field unit register 2. After receiving a response from the field unit, write the value of 6656 to the field unit register 1. The actuator will then move to a position of 42% of open.

First Command

Query: B3060001002A4207

Response: B3060001002A4207

First Command Message Breakdown

Query		Response	
B3	Slave (Field Unit) Address	B3	Slave (Field Unit) Address
06	Function	06	Function
00	Register Address Hi	00	Register Address Hi
01 ¹	Register Address Lo	01	Register Address Lo
00	Force Data Hi	00	Preset Data Hi
2A ²	Force Data Lo	2A	Preset Data Lo
4207	Error Check (CRC)	4207	Error Check (CRC)

Note 1: 001h equals Register Address 40002 (field unit register 2, argument register).

Note 2: 002Ah equals 42.

Second Command

Query: B30600001A009978

Response: B30600001A009978

Second Command Message Breakdown

Query		Response	
B3	Slave (Field Unit) Address	B3	Slave (Field Unit) Address
06	Function	06	Function
00	Register Address Hi	00	Register Address Hi
00 ¹	Register Address Lo	00	Register Address Lo
1A	Force Data Hi	1A	Preset Data Hi
00 ²	Force Data Lo	00	Preset Data Lo
9978	Error Check (CRC)	9978	Error Check (CRC)

Note 1: 0000h equals Register Address 40001 (field unit register 1, command register).

Note 2: 1A00h equals 6656.

Example of Single Register Write “Move-To” Command

This command allows a Host to issue the “move-to” command with a single write utilizing Modbus FC 06. Register 1 will be used to complete this command.

Rules for utilizing this command:

- Field unit scaling must be configured for 0-100.
- To use the hexadecimal method of determining a single write “move-to” command, 0x4B is always placed into the Hi byte of register 1. The desired position value is always placed into the Lo byte of register 1.

- To move the actuator to a position of 50%, place the value 0x4B in the Hi byte and the value of 0x32 (50 decimal) into the Lo byte.

Hex format: 0x4B32

To use the decimal method of determining a single write “move-to” command, add the desired position value to 19200.

Desired position: 50%

19200 + 50 = 19250

Move an actuator at address 1 to 50% of open by writing the value of 19250 (0x4B32) to the field unit register 1. The actuator will then move to a position of 50% open.

Query: 010600004B323EEF

Response: 010600004B323EEF

Message Breakdown

Query		Response	
01	Slave (Field Unit) Address	01	Slave (Field Unit) Address
06	Function	06	Function
00	Starting Address Hi	00	Starting Address Hi
00	Starting Address Lo	00	Starting Address Lo
4B	Preset Data Hi	4B	Preset Data Hi
32	Preset Data Lo	32	Preset Data Lo
3EEF	Error Check (LRC or CRC)	3EEF	Error Check (LRC or CRC)

2.3.9 Modbus Function Code 07 (Read Exception Status)

This function code is used to detect if a change in status or fault data has occurred within the field unit. Using this function code as the primary method of communication with a field unit is commonly referred to as Poll By Exception mode. This mode of operation requires that the field unit first be configured to use Modbus FC 07.

Once Poll By Exception is enabled any combination of Registers 8, 9, 10, 12, and 13 within the field unit can be monitored for changes. A normal response to the (07) command will indicate whether or not a change within the monitored register range has occurred (00h = No, FFh = Yes). Note that the field unit will continue to report that a change has occurred until the entire range of monitored registers is read using Modbus FC 03.

Additionally, when Poll By Exception is enabled the field unit will not report DDC Comm Loss due to network inactivity. This modification is done in order to further support an event-based mode of operation.

Poll By Exception mode was first introduced to MX-DDC field units in Firmware 14/06.00. Therefore this version (or greater) must be present on the field unit in order to use Modbus FC 07.

Example

Poll field unit number 27 to determine if any change in the Poll By Exception monitored register set has occurred.

Query: 1B074A82

Response: 1B070003F7

Message Breakdown

Query		Response	
1B	Slave (Field Unit) Address	1B	Slave (Field Unit) Address
07	Function	07	Function
4A82	Error Check (LRC or CRC)	00	Exception Status
		03F7	Error Check (LRC or CRC)

Note 1: 00h means no change has occurred since last poll

2.3.10 Modbus Function Code 08 (Diagnostics)

This function code provides a series of tests for checking the communication system between the Host and field units (slaves), or for checking various error conditions within the field unit. This function code uses a two-byte subfunction code field in the query to define the type of test to be performed. The normal response to the (08) command echoes both the function code and subfunction code.

A listing of the supported diagnostic two-byte subfunction codes is given in **Table 2.7**.

Example

Request a loopback (return query data) from the field unit at network address 3.

Query: 030800000000E1E9

Response: 030800000000E1E9

Message Breakdown

Query		Response	
03	Slave (Field Unit) Address	03	Slave (Field Unit) Address
08	Function	08	Function
00	Subfunction Hi	00	Subfunction Hi
00	Subfunction Lo	00	Subfunction Lo
00	Data Hi	00	Data Hi
00	Data Lo	00	Data Lo
E1E9	Error Check (CRC)	E1E9	Error Check (CRC)

Table 2.7 – Diagnostic Codes

Code	Name
00	Return Query Data
01	Restart Communication Option
02	Return Diagnostic Register ¹
03	Change ASCII Input Delimiter
04	Force Listen-Only Mode
10 (0A Hex)	Clear Counters and Diagnostics Register
11 (0B Hex)	Return Bus Message Count
12 (0C Hex)	Return Bus Communication Error Count
13 (0D Hex)	Return Bus Exception Error Count
14 (0E Hex)	Return Slave Message Count

Note 1: Contains DDC-100 Field Unit diagnostic information. For engineering use only.

2.3.11 Modbus Function Code 15 (Force Multiple Coils)

This function code allows the user to force multiple coils with a single command and uses the same coil assignments as the function code 05.

It should be noted that the coils are operated from the lowest coil number to the highest. Forcing coil 1 or 2 OFF (0) is considered a stop command. Sending a 15 command to force two coils starting with coil 1, with coil 1 ON and coil 2 OFF, would result in the unit stopping since coil 2 is forced OFF after coil 1 is forced ON.

To prevent inadvertent Stop commands from being issued, it is recommended to force one coil at a time.

Available digital outputs for DDC-100 Field Units are listed in **Table 2.5**. Force multiple coil commands should be issued only once for the desired field unit control. Repeated issuance of an acknowledged command will degrade network performance. The normal response to the (15) command returns the slave address, function code, starting address, and quantity of coils forced.

Example of force coil command

Force coil 1 of field unit 1 ON. This will CLOSE the valve controlled by field unit 1.

Query: 010F000000010101EF57

Response: 010F00000001940B

Message Breakdown

Query		Response	
01	Slave Address	01	Slave Address
0F	Function	0F	Function
00	Coil Address Hi	00	Coil Address Hi
00	Coil Address Lo	00	Coil Address Lo
00	Quantity of Coils Hi	00	Quantity of Coils Hi
01	Quantity of Coils Lo	01	Quantity of Coils Lo
01	Byte Count	940B	Error Check (LRC or CRC)
01	Force Data Lo		
EF57	Error Check (LRC or CRC)		

*Note: 00000010101h equals Coil Address 00000001 (field unit coil 1)
000100010101h equals Coil Address 00000010 (field unit coil 2)*

2.3.12 Modbus Function Code 16 (Preset Multiple Registers)

This function code is used to preset single or multiple registers in the field unit and uses the same predetermined register values as the function code 06. This function code is typically used to command the DDC-100 Field Unit by writing values to registers 1 (Command) and 2 (Argument).

Modbus FC 16 command values for controlling the DDC-100 Field Unit are given in **Table 2.6**. Each command should be issued only one time for the desired field unit control. Repeated issuance of an acknowledged command will degrade network performance. The normal response to the (16) command returns the slave address, function code, starting address, and quantity of registers preset.

Example of Field Unit Command

Write the command to open an actuator (actuator open) to field unit number 1. This corresponds to writing the value 256 into field unit register 1.

Query: 011000000001020100A7C0

Response: 01100000000101C9

Message Breakdown

Query		Response	
01	Slave Address	01	Slave Address
10	Function	10	Function
00	Starting Address Hi	00	Starting Address Hi
00	Starting Address Lo	00	Starting Address Lo
00	Number of Registers Hi	00	Number of Registers Hi
01	Number of Registers Lo	01	Number of Registers Lo
02	Byte Count	01C9	Error Check (LRC or CRC)
01	Preset Data Hi		
00	Preset Data Lo		
A7C0	Error Check (LRC or CRC)		

Example of “Move-To” Command

Move an actuator at address 1 to 50% of open by presetting registers 1 with the value 6656 and register 2 (Argument) with the value 50 in a single write command. The actuator will receive this message and move to a position of 50% open.

Query: 011000000002041A0000327562

Response: 01100000000241C8

Message Breakdown

Query		Response	
01	Slave Address	01	Slave Address
10	Function	10	Function
00	Starting Address Hi	00	Starting Address Hi
00	Starting Address Lo	00	Starting Address Lo
00	No. of Registers Hi	00	No. of Registers Hi
02	No. of Registers Lo	02	No. of Registers Lo
04	Byte Count	41C8	Error Check (LRC or CRC)
1A	Preset Data Hi		
00	Preset Data Lo		
00	Preset Data Hi		
32	Preset Data Lo		
7562	Error Check (LRC or CRC)		

This function code may also utilize the Single Register write “move-to” command.

2.3.13 Modbus Function Code 17 (Report Server ID)

This function code is used to retrieve a collection of useful identification information from the field unit. Note that the size & contents of the normal response will vary depending on the actuator type being addressed. **Appendix C** contains an in-depth explanation of the identification information provided by the various Flowserve Limitorque actuator types.

The Report Server ID feature was first introduced to MX-DDC field units in Firmware 14/06.00. Therefore this version (or greater) must be present on the field unit in order to use Modbus FC 17.

Example

Poll field unit number 4 to obtain identification information from the field unit.

Query: 0411C37C

Response: 04113B00003038353938343630323031363031323031303232323590464C534D582D313233343536373820203364D30342E3031008F00920400166001000985

Message Breakdown (MX)

Query		Response	
04	Slave Address	04	Slave Address
11	Function	11	Function
C37C	Error Check (LRC or CRC)	3B	Byte Count
		00	Server ID
		00	Run Indication
		3038353938343630	QA Stamp
		3230313630313230	QA Date
		313032323235	QA Time
		90	MOV Type
		464C534D582D31323334353637382020	Tag Name
		31364D30342E3031	Main Board Application
		008F	Main Board Bootloader
		0092	Main Board CPLD
		04	Modbus DDC Version
		0016	Unit Size, Voltage, Frequency, and Starter Configuration
		60	Unit RPM
		0100	Capabilities
		0985	Error Check (LRC or CRC)

Note 1: Detailed description of MX ID data available in Appendix C.

Query: 0411C37C

Response: 04114C00003038353938343630323031363031323031303232323560464C5351582E3132333435363738202031365130342E303100910092054D432E30312E313542542E30312E30320101001801005400

Message Breakdown (QX & QXM)

Query		Response	
04	Slave Address	04	Slave Address
11	Function	11	Function
C37C	Error Check (LRC or CRC)	4C	Byte Count
		00	Server ID
		00	Run Indication
		3038353938343630	QA Stamp
		3230313630313230	QA Date
		313032323235	QA Time
		60	MOV Type
		464C5351582D31323334353637382020	Tag Name
		31365130342E3031	Main Board Application
		0091	Main Board Bootloader
		0092	Main Board CPLD
		05	Modbus DDC Version
		4D432E30312E3135	Motor Controller Application
		42542E30312E3032	Motor Controller Bootloader
		01	Encoder Firmware
		0100	Unit Size, Voltage, Frequency, and Starter Configuration
		18	Unit RPM
		0100	Capabilities
		5400	Error Check (LRC or CRC)

Note 1: Detailed description of QX & QXM ID data available in Appendix C.

2.3.14 Modbus Function Code 23 (Read/Write Multiple Registers)

This function code is used to consolidate a Preset Multiple Registers (FC 16) command and a Read Holding Register (FC 03) command into a single Modbus exchange with the field unit. Note that the order of operations followed by the field unit is to execute the write operation(s) first, then the read operation.

Consult the Read Holding Register (FC 03) and Preset Multiple Registers (FC 16) sections for additional details on how the write & read portions of this command are constructed & processed.

The Read/Write Multiple Registers feature was first introduced to MX-DDC field units in Firmware 14/06.00. Therefore this version (or greater) must be present on the field unit in order to use Modbus FC 23.

Example

Write the command to close an actuator to field unit number 108 and readback the status to confirm the actuator is moving in the close direction.

This corresponds to writing the value 768 into register 1 and reading back the contents of register 9.

Query: 6C1700080001000000010203004759

Response: 6C17020011D071

Message Breakdown

Query		Response	
6C	Slave Address	6C	Slave Address
17	Function	17	Function
00	Read Starting Address Hi	02	Read Byte Count
08	Read Starting Address Lo	00	Read Data Hi
00	No. of Read Registers Hi	11	Read Data Lo
01	No. of Read Registers Lo	D071	Error Check (LRC or CRC)
00	Write Starting Address Hi		
00	Write Starting Address Lo		
00	No. of Write Registers Hi		
01	No. of Write Registers Lo		
02	Write Byte Count		
03	Write Data Hi		
00	Write Data Lo		
4759	Error Check (LRC or CRC)		

Note 1: 0008h equals Register Address 40009 (field unit register 9, status register)

Note 2: 0000h equals Register Address 40001 (field unit register 1, command register)

Note 3: 0300h equals 768 Decimal (close actuator)

Note 4: 0011h equals 17 Decimal (actuator in remote mode, opened and closing)

3 Installation and Configuration

3.1 Site and Network Cable Preparation

3.1.1 Site Preparation

Prepare the site and associated equipment for operation of the DDC-100 controlled actuators as follows:

1. Prepare a detailed site plan consisting of the following:
 - Actuator locations, tag numbers, DDC addresses
 - Junction boxes, terminal strip locations, and tag numbers
2. Provide free access to the control panel and terminal block for setup, configuration, and troubleshooting.
3. Prepare cable and label all wires. See **Section 3.1.2, Network Cable Preparation.**
4. Install power and control wires in separate conduits. Shielding is not sufficient to prevent induction of stray voltages onto signal leads from the power lines.
5. Install and verify earth grounds.

NOTE: Limitorque defines an effective local earth ground as a low impedance (less than 5 ohms) path to:

- A ground electrode placed in close vicinity of the actuator that is free of ground loop currents. **OR**
- A safety ground that is free of ground loop currents running from the actuator back to the system ground electrode. If the signal wiring is run on aerial cable where it may be exposed to high-energy electrostatic discharge (such as lightning), a low impedance path to ground that is capable of high current must be provided a short distance from the actuator as described above. **OR**
- A power distribution grid identifying the impact of power isolation to a particular actuator or group of actuators should be provided.

3.1.2 Network Cable Preparation

3.1.2.1 Network Cable Connection to the Field Unit

The DDC-100 field unit is connected to the network via the terminal block. For RS-485 segments, the network cable is connected to the terminal block as shown in **Figure 3.1.**

Figure 3.1 – RS-485 Network Connections

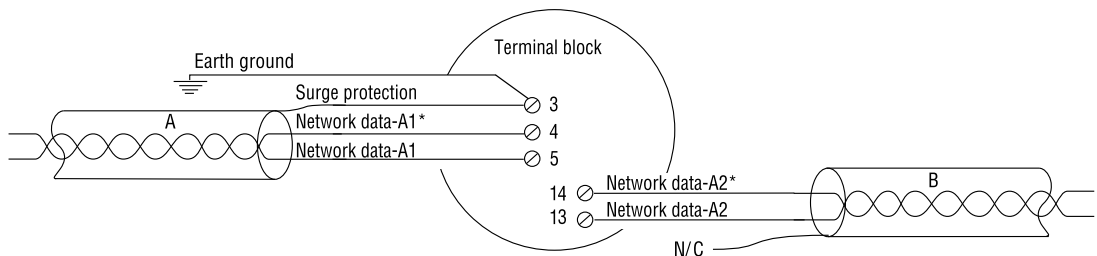

For Ethernet segments, the network cable is connected to the terminal block with the help of the RS-485 to Ethernet adapter as shown in **Figure 3.2.**

Figure 3.2 - Ethernet Network Connections

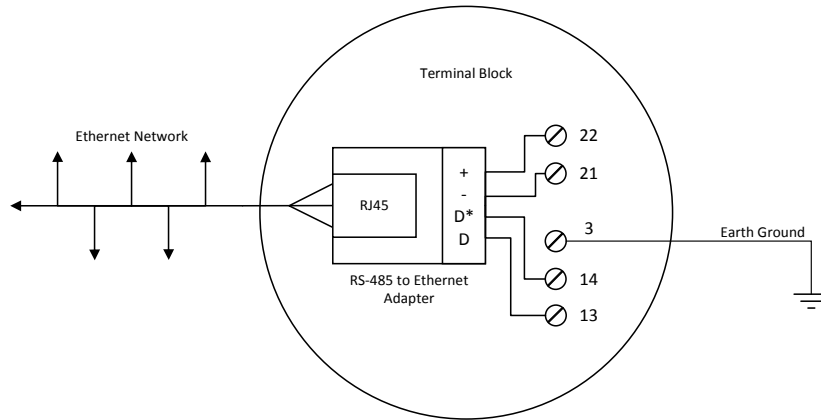

NOTE:

1. Shielded cables should be used.
2. Shields are connected to earth ground at one end only to avoid ground loops.
3. Clean earth-ground connection (less than 5 ohms) enhances noise rejection and provides a clear/safe path for surge currents.

Prepare the network cable for connection to the terminal block as follows.

▲ CAUTION: Strip stranded conductors carefully; do not damage the strands. This will weaken the conductor. Do not nick conductors or conductor insulation when stripping away the insulation. Nicking stresses the conductor and can cause the conductor to break. This type of damage may not be apparent and failure can occur later without warning.

NOTE: Multi-pair cables should provide shielding for each conductor pair.

NOTE: Excess cable should be cut, not coiled or looped, to prevent noise induction into the network and to reduce signal loss through unnecessarily long cable runs.

Cable Preparation

1. Remove two to three inches (5 to 8 cm) of the outer plastic jacket as shown in **Figure 3.3**.

Figure 3.3 – Removing outer plastic jacket



2. Separate the cable parts. Unbraid the shield and peel back the foil shield to the same point where the outer jacket was removed as shown in **Figure 3.4**.

Figure 3.4 – Separating cable parts

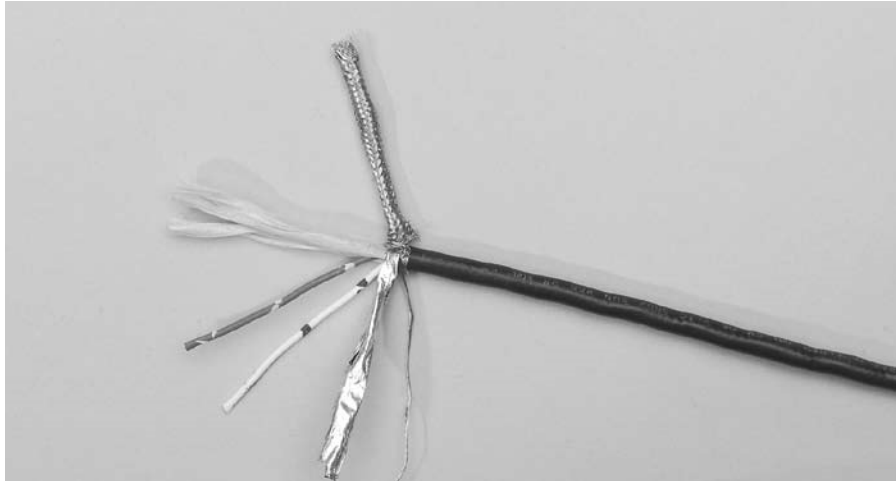

3. Cut away the braided shield and the foil shield. Strip the insulation from the conductors approximately 0.4 inch (1 cm) as shown in **Figure 3.5**.

Figure 3.5 – Stripping conductors

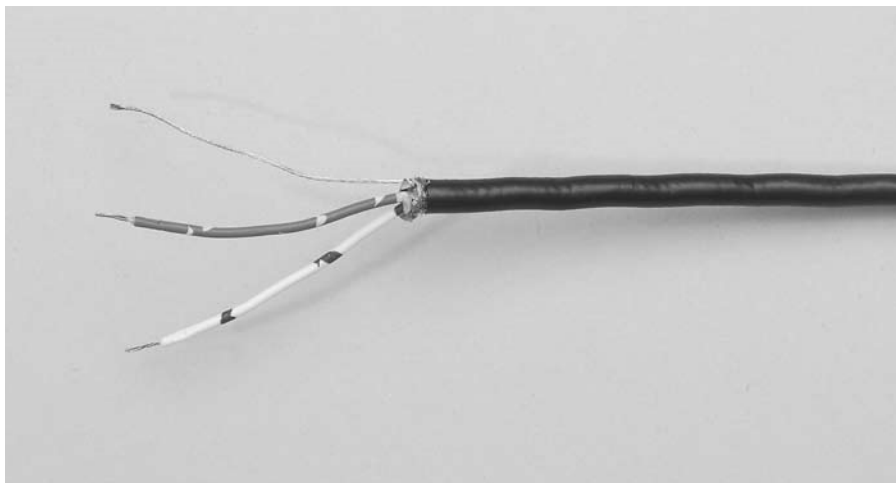

4. Apply heat shrink tubing to insulate the drain wire and to provide stress relief to the cable as shown in **Figure 3.6**.

Figure 3.6 – Applying heat shrink tubing



▲ CAUTION: Do not melt the insulation.

NOTE: Ungrounded drain wires should be cut even with the cable sheath. The braided shield and drain wire should have heat shrink tubing applied.

5. Install ring tongue connectors as shown in **Figure 3.7**.
Flowserve recommends the use of Thomas & Betts #RZ22-6 for optimum results.

Figure 3.7 – Ring tongue connectors

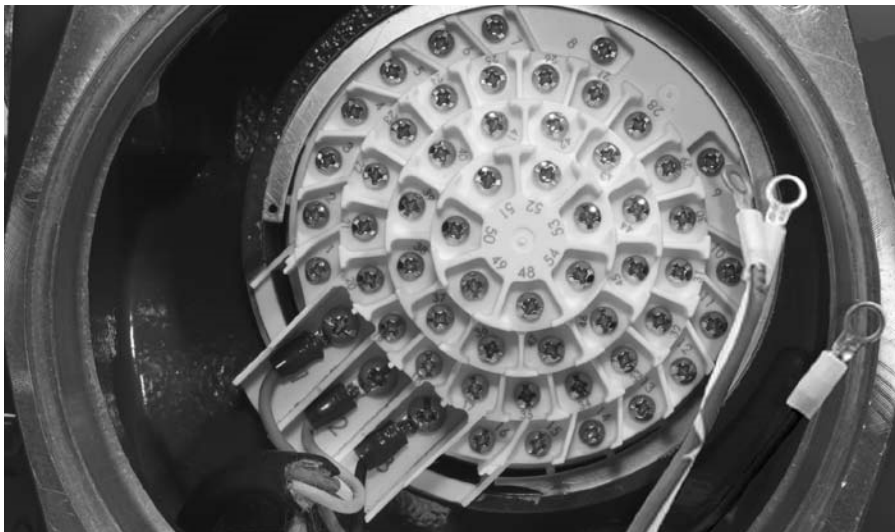

6. Connect the network cables to the terminal block as shown in **Figure 3.8**. **Table 3.3** defines each network cable termination. Refer to **Figures 3.9 and 3.10** for topology-specific wiring connections.

Table 3.3 – Network cable terminations

Terminal Block Number	Function
4	NETWORK (A2*)
5	NETWORK (A2)
14	NETWORK (A1*)
13	NETWORK (A1)
3	NETWORK SURGE (EGND)

NOTE: Ground each segment of the cabling at only one point to prevent ground loops, which can affect system performance. Verify the actuator is properly grounded.

7. Install jumper cable from terminal block pin 3 to earth ground or ground lug.

Figure 3.8 – Connecting network cable to terminal block

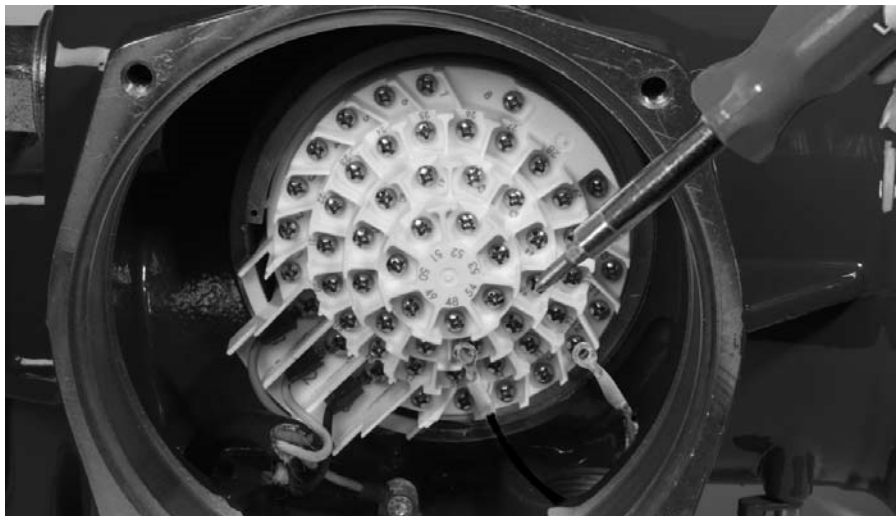

3.1.2.2 Network Cable Connection to Host Controller or Master Station

Two network topologies are commonly used and supported for Limitorque actuators:

- Redundant bi-directional loop (recommended)
- Daisy chain

Redundant Bi-Directional Loop

The redundant bi-directional loop topology requires two serial communication ports on the host device.

- Each field unit can be accessed by two host/master ports.
- The connections from the serial ports to the field units and connections between field units are made with shielded, twisted-pair cable in a loop configuration.
- A single line break or short can occur while maintaining communication to all field units.

The redundant bi-directional loop topology is wired as follows (see **Figure 3.9**):

1. Connect the host device port 1, through a signal converter if required, to the first field unit port A1 at terminal block numbers 14 and 13.
2. Connect the port A2 at terminal block numbers 4 and 5 to the next field unit's port A1.
3. Each subsequent field unit is connected in the same manner – receiving data through its port A1, then passing the data out through its port A2 to the next field unit.
4. The last field unit's port A2 is connected to the host device's port 2. The host device should be configured to ignore messages that it sends out when it returns to its other port.

The direction of data flow can be reversed because of the bi-directional capability of the serial ports.

- a. Communications can be initiated by connecting host port 2 to first field unit port A2.
- b. Port A1 of the first field unit is then connected to port A2 of the next field unit.
- c. Port A1 of the last field unit is then connected to host port 1.

In either direction, the signal is regenerated in each field unit to permit long-distance communication with reduced noise sensitivity and improved reliability.

Figure 3.9 – Redundant bi-directional loop topology

Legend

- MOV - Motor-operated valve
- 13 - Data A1
- 14 - Data A1*
- 5 - Data A2
- 4 - Data A2*
- 3 - Shield
- N/C - No connection

Data terminal is positive with respect to data* terminal

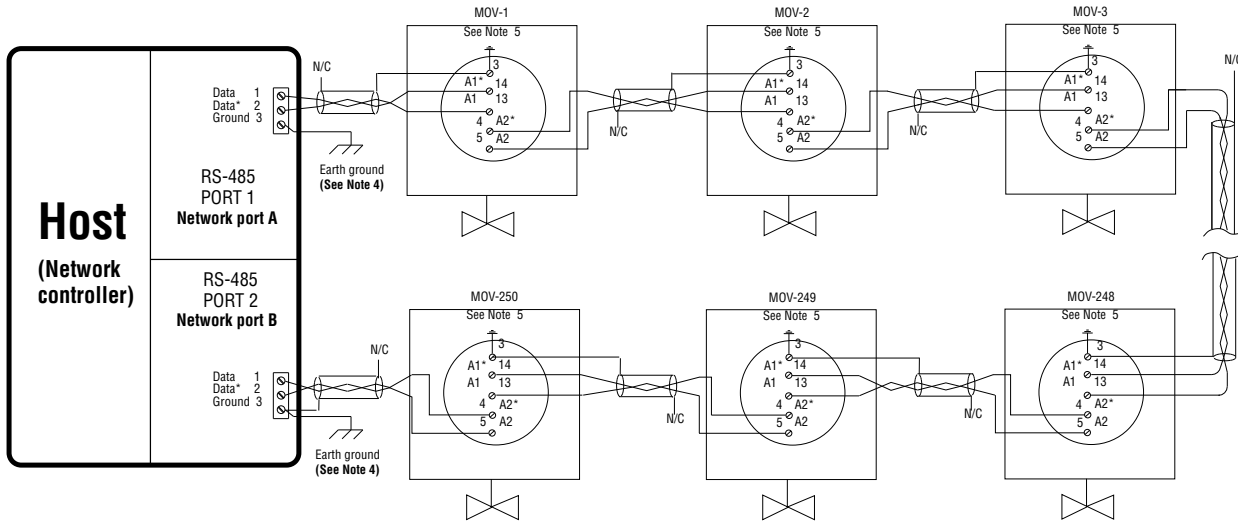

Notes:

1. Belden 3074F, 3105A, or 9841 shielded cable is recommended.
2. Correct polarity for field unit and network controller connection is necessary for proper operation.
3. Connections shown are typical. The number of MOVs shown may not indicate true system size.
4. ↗ Earth ground: ground rod
5. ↗ Earth ground: ground rod or lug in actuator if actuator is grounded.

Diagnostic note:

Polarity and level of the network's data connection can be checked by measuring voltage between data and data* terminals. This voltage should be greater than +200 mV DC with network controller (host) network ports disconnected. Data terminal is positive with respect to data* terminal.

Earth ground note:

If low impedance earth ground is not available at each actuator, contact engineering for alternative earth ground surge protection strategies.

Daisy Chain

The daisy chain topology is identical to the redundant loop topology with the following exception - only one end of the network is connected to the host device.

The daisy chain topology is wired as follows:

1. Connect the host port 1 to the first field unit port A1 at terminal block numbers 14 and 13.
2. Connect port A2 of this field unit at terminal block numbers 4 and 5 to port A1 of the next field unit.
3. Continue steps 1 and 2 until the last field unit is connected.

NOTE: If a stub cable is run from port A2 of the last field unit (terminal block numbers 4 and 5) to a planned field unit location, or the last field unit is disconnected, the open end of the cable must be terminated with a 120 ohm resistor to prevent unacceptable signal reflections. Termination impedance is supplied when the actuator field unit is the last unit.

The daisy chain topology utilizes the field unit repeater circuitry, and therefore supports the same number of field units and distances as the redundant bi-directional loop topology. However, the daisy chain topology is less reliable than the redundant bi-directional loop topology because the host can only reach the field units from one direction. If a data cable break occurs, communication will be lost to all nodes on the far side of the break.

Figure 3.10 – Daisy chain topology

Legend

- MOV - Motor-operated valve
- 13 - Data A1
- 14 - Data A1*
- 5 - Data A2
- 4 - Data A2*
- 3 - Shield
- N/C - No connection

Data terminal is positive with respect to data* terminal

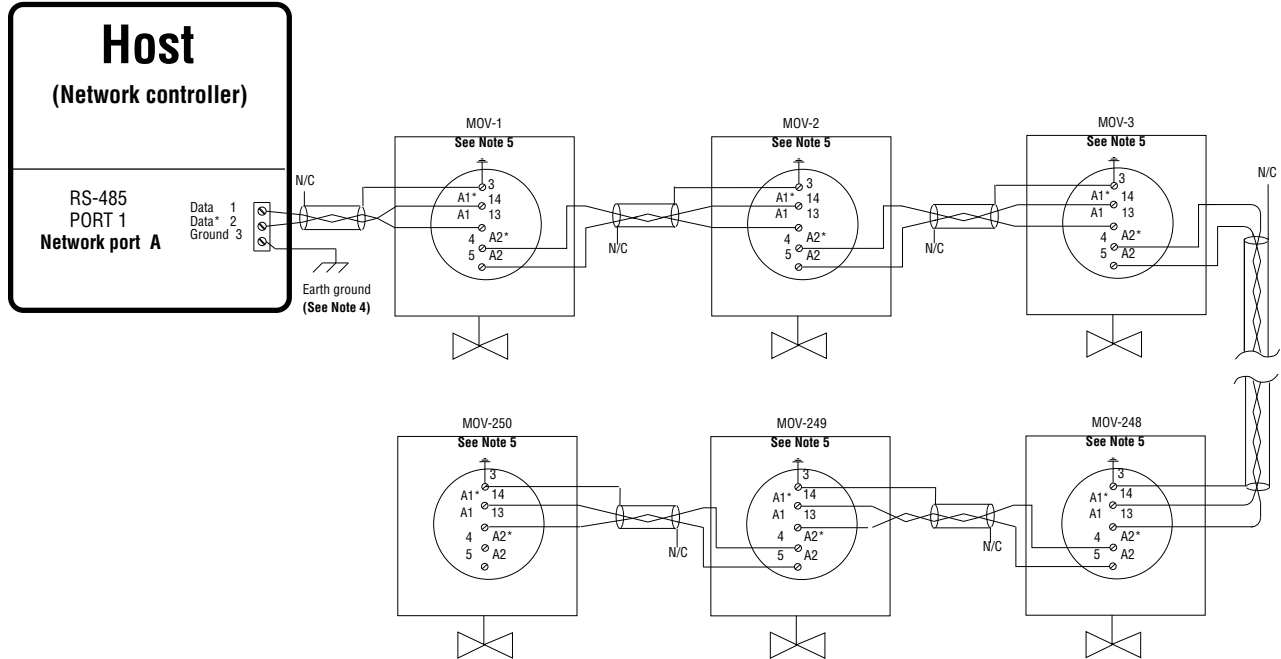

Notes:

1. Belden 3074F, 3105A, or 9841 shielded cable is recommended.
2. Correct polarity for field unit and network controller connection is necessary for proper operation.
3. Connections shown are typical. The number of MOVs shown may not indicate true system size.
4. ⚡ Earth ground: ground rod
5. ⚡ Earth ground: ground rod or lug in actuator if actuator is grounded.

Diagnostic note:

Polarity and level of the network's data connection can be checked by measuring voltage between data and data* terminals. This voltage should be greater than +200 mV DC with network controller (host) network ports disconnected. Data terminal is positive with respect to data* terminal.

Earth ground note:

If low impedance earth ground is not available at each actuator, contact engineering for alternative earth ground surge protection strategies.

RS-485 to Ethernet Adapter Configurations

For host systems that use Modbus TCP/IP communication there are two common methods of utilizing the RS-485 to Ethernet adapter to incorporate Limatorque actuators into the network.

Figure 3.11 - Gateway configuration for RS-485 to Ethernet Adapter

Legend

- MOV - Motor-operated valve
- 13 - Data A1
- 14 - Data A1*
- 5 - Data A2
- 4 - Data A2*
- 3 - Shield
- N/C - No connection

Data terminal is positive with respect to data* terminal

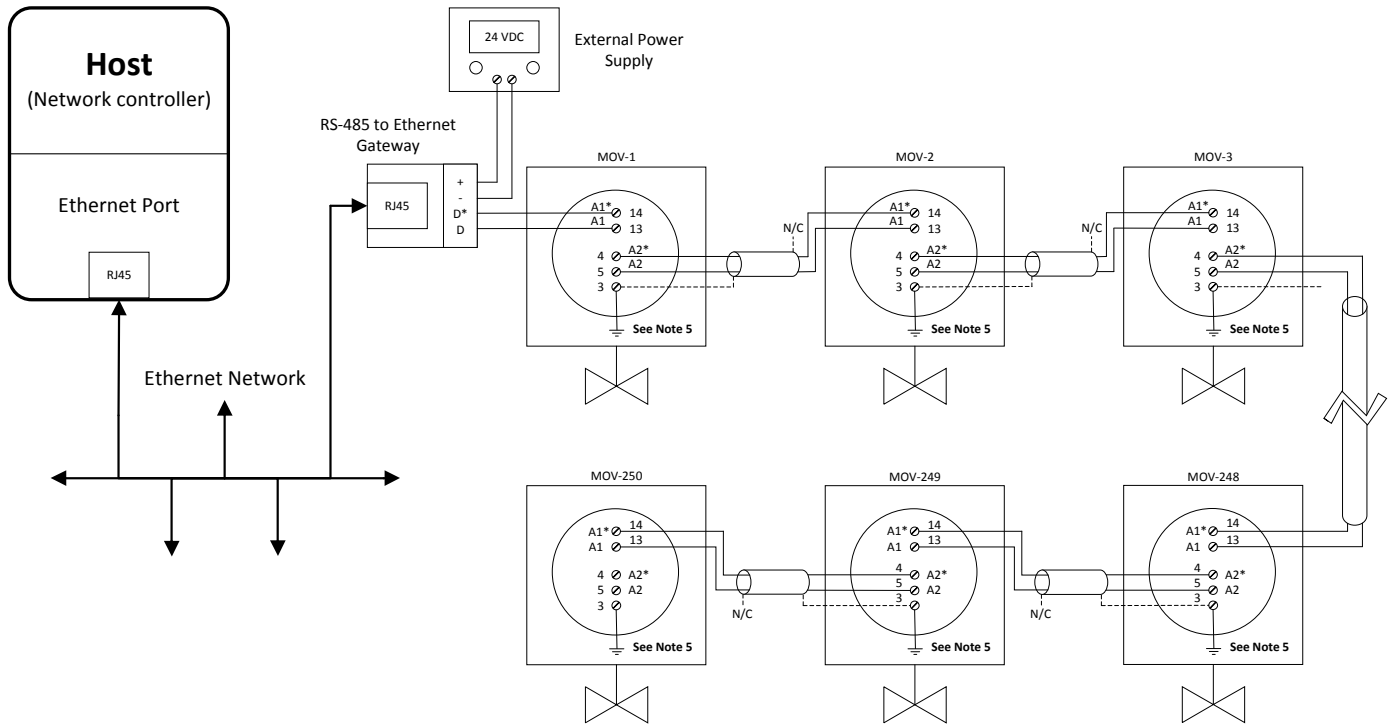

Notes:

1. Belden 3074F, 3105A, or 9841 shielded cable is recommended.
2. Correct polarity for field unit and network controller connection is necessary for proper operation.
3. Connections shown are typical. The number of MOVs shown may not indicate true system size.
4. ↗ Earth ground: ground rod
5. ↗ Earth ground: ground rod or lug in actuator if actuator is grounded.

Diagnostic note:

Polarity and level of the network's data connection can be checked by measuring voltage between data and data* terminals. This voltage should be greater than +200 mV DC with network controller (host) network ports disconnected. Data terminal is positive with respect to data* terminal.

Earth ground note:

If low impedance earth ground is not available at each actuator, contact engineering for alternative earth ground surge protection strategies.

Figure 3.12 - Slave configuration for RS-485 to Ethernet Adapter

Legend

- MOV - Motor-operated valve
- 13 - Data A1
- 14 - Data A1*
- 5 - Data A2
- 4 - Data A2*
- 3 - Shield
- N/C - No connection

Data terminal is positive with respect to data* terminal

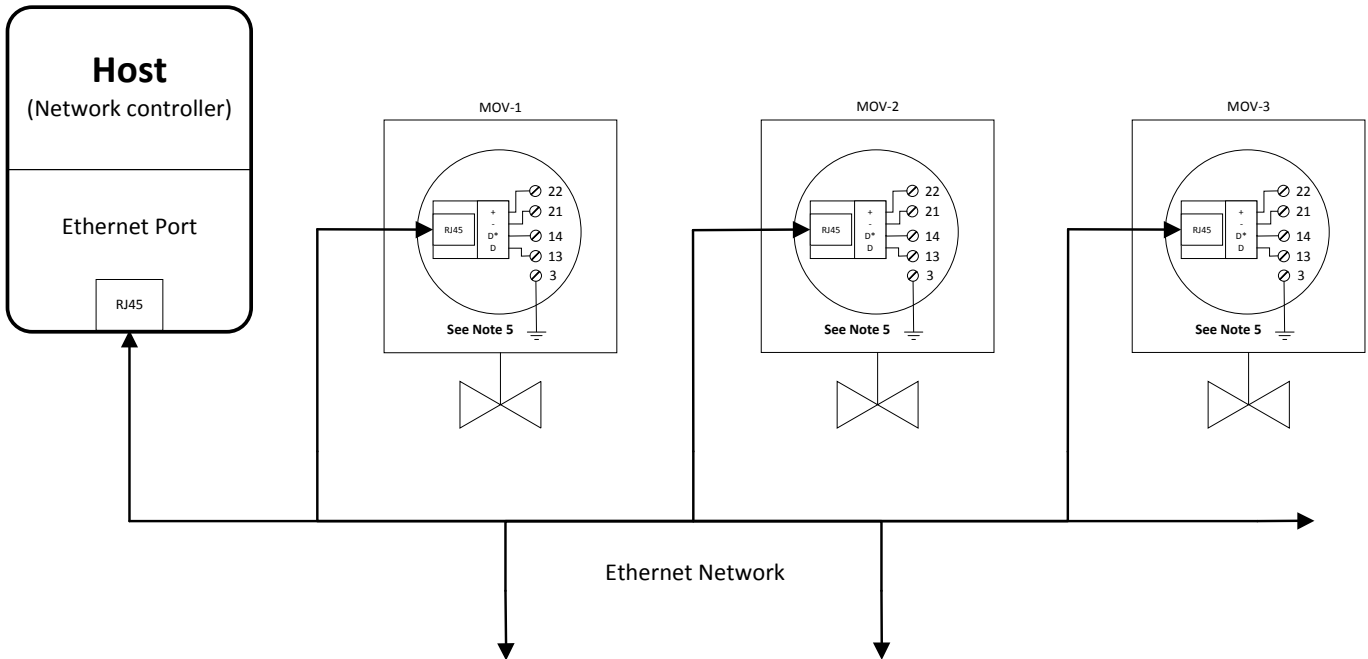

Notes:

1. Belden 3074F, 3105A, or 9841 shielded cable is recommended.
2. Correct polarity for field unit and network controller connection is necessary for proper operation.
3. Connections shown are typical. The number of MOVs shown may not indicate true system size.
4. ↗ Earth ground: ground rod
5. ↗ Earth ground: ground rod or lug in actuator if actuator is grounded.

Diagnostic note:

Polarity and level of the network's data connection can be checked by measuring voltage between data and data* terminals. This voltage should be greater than +200 mV DC with network controller (host) network ports disconnected. Data terminal is positive with respect to data* terminal.

Earth ground note:

If low impedance earth ground is not available at each actuator, contact engineering for alternative earth ground surge protection strategies.

3.2 Installation Verification

3.2.1 Network Cabling Installation Verification

After installation is complete and prior to operation, inspect the network cable and its connection to each field unit for the following:

NOTE: Units should be disconnected from power. Network should be disconnected from host.

1. There should be:
 - No nicks in the insulation—this can cause a short between conductors or to the grounded shield.
 - No cut strands in a stranded conductor—this can cause a poor connection and eventually an open circuit.
2. Verify that there is data wiring on each actuator per wiring diagram.
3. Cable armor should not be shorted to the cable shield/drain wire. Cable armor may not be at ground potential and could be subject to lightning surges.
4. The shield/drain wire should only be grounded at one end of each cable segment (the section between adjacent actuators or between the host system/Master Station and an actuator) to avoid ground loop problems.
5. The ground/earth connection should be at true ground potential and effective at all times. See No. 5 in **Section 3.1.1, Site Preparation**.

For RS-485 redundant bi-directional loops, use a voltmeter in the control room. Determine the following by measuring resistance of individual wires in the network cables:

NOTE: Power must be OFF on all field devices, and A1/A2 cables must be disconnected from the network host.

1. Data wire A1 to data wire A2 should be equal to the resistance value of network cable length/cable resistance per 1000 ft.
2. Data* wire A1 to data* wire A2 should be equal to the resistance value of network cable length/cable resistance per 1000 ft.
3. Confirm open circuit between data and data* cables.
4. Confirm open circuit between data, data*, and shield.
5. Confirm open circuit between shield and shield.

3.2.2 RS-485 to Ethernet Adapter Installation Verification

NOTE: Connect to 24 VDC and apply power.

Verify the adapter is installed as follows:

1. Confirm RS-485 and Ethernet cabling is properly installed.
2. Confirm adapter is active using the LEDs on the device (should be blinking).

3.2.3 Field Unit Installation Verification

NOTE: Connect to either 24 VDC power or mains and activate power.

Verify the field unit is installed as follows:

1. Enter the “**SETUP**” mode as detailed in **Bulletin LMENIM2306, MX Installation and Operation Manual**.
2. In the “**SETUP**” mode, use the black control knob to select “**YES**” to the main menu selection “**VIEW DIAGNOSTICS?**”
3. Select “**YES**” to the display “**VIEW HARDWARE STATUS?**”

4. Select “**YES**” to scroll through the menu selections. The LCD will read “**DDC (OK) – NEXT?**” if installed. **NOTE:** If the “**DDC (OK) – NEXT?**” does not appear, contact Flowserve for assistance.
5. To return to the normal display, use the red knob to select either “**LOCAL**” or “**REMOTE.**”

3.3 Field Unit Configuration

The actuator has been configured with all customer-specified parameters and no further calibration should be necessary. Only the address needs to be configured. If full valve data was not provided when ordering, or if changes are needed for parameters other than the DDC option, refer to Bulletin **LMENIM2306, MX Installation and Operation Manual**. If any changes to the DDC configuration are required, see **Section 3.3.1, Configuring Field Unit Parameters**.

3.3.1 Configuring Field Unit Parameters

The following instructions assume that all DDC parameters are set, except the address.

1. Enter the “**SETUP**” mode as detailed in Bulletin **LMENIM2306, MX Installation and Operation Manual**.
2. When LCD reads “**CHANGE SETTINGS?**”, use the black knob to select “**YES.**”
3. Enter the password (Default=100).
4. The LCD will display the “**CHANGE SETTINGS**” mode menu items. Select “**NO**” until screen displays “**CHANGE DDC?**” Select “**YES.**” LCD will display DDC menu items.
5. Select “**YES**” to each menu item until “**DDC ADDRESS OK?**” appears. Select “**NO**” if address displayed is not correct.
6. Enter an address from 1 to 250 by toggling “**NO**” until the correct address is displayed.
7. Return red selector switch to “**REMOTE**” or “**LOCAL**” to save address.

▲ CAUTION: The network address must be entered in accordance with the user address assignment sheet. This assignment sheet should correspond to the contract specifications. The same address must not be used anywhere else in the same network.

All DDC parameters have been factory-set in accordance with customer specifications or defaults. These parameters may be viewed or changed as described in **Bulletin LMENIM2306, MX Installation and Operation Manual**.

3.3.1.1 Viewing DDC Parameters

Enter the “**VIEW SETTINGS**” mode and “**VIEW DDC?**” as detailed in **Bulletin LMENIM2306, MX Installation and Operation Manual**. The display will show the state or value of the following menu items:

- | | |
|----------------------|---------------------------|
| • Status | • ESD Action |
| • Protocol | • FC 07 Config |
| • Parity & Stop Bits | • Combined Fault Warnings |
| • Baud Rate | • Proportional Band |
| • DDC Address | • Deadband |
| • Topology | • Comm Loss Action |
| • Analog Scale | • Comm Loss Delay |

NOTE: “**VIEW DDC?**” will not appear if the DDC-100 Network Board is not installed. If the “**VIEW DDC?**” does not appear, contact Limitorque.

3.3.1.2 Changing DDC Parameters

Enter the “**CHANGE SETTINGS**” mode and “**CHANGE DDC?**” as detailed in **Bulletin LMENIM2306, MX Installation and Operation Manual**. The following parameters may be changed:

- Status
- Protocol
- Parity & Stop Bits
- Baud Rate
- DDC Address
- Topology
- Analog Scale
- ESD Action
- FC 07 Config
- Combined Fault Warnings
- Proportional Band
- Deadband
- Comm Loss Action
- Comm Loss Delay

Each parameter is discussed below:

Status

This parameter activates or deactivates the Modbus interface on the field unit.

NOTE: When the field unit is installed at the factory, the default status is ON. If DDC status is OFF, the LCD screen will display “**XXX% OPEN, DDC OFF.**”

Use the black control knob to select “**NO**,” which toggles the Modbus interface OFF and ON.

Protocol

The protocol parameter selected depends on the system design. All field units and the host system/Master Station must have the same protocol.

Use the black control knob to select “**NO**”, which toggles the protocol setting. The protocol options are:

RTU

- Timing-based frame format for Modbus communication.
- Data is presented in hexadecimal.

ASCII

- Delimiter-based frame format for Modbus communication.
- Data is presented in ASCII characters

Select “**YES**” to choose the desired protocol. The default setting is RTU.

Parity & Stop Bits

The parity & stop bit parameters selected depend on the system design. All field units and the host system/Master Station must have the same parity and stop bits.

Using the black control knob, select “**NO**” until the desired parity & stop bit combination is displayed. The valid combinations are:

- NONE/1
- NONE/2
- EVEN/1 (stop bits not shown, forced to use 1)
- ODD/1 (stop bits not shown, forced to use 1)

Select “**YES**” to choose the desired parity & stop bit combination. The default setting is NONE/1.

Baud Rate

The baud rate parameter selected depends on the system design. All field units and the host system/ Master Station must have the same baud rate.

Using the black control knob, select “**NO**” until the desired baud rate is displayed. The baud rate options are:

- 1200
- 2400
- 4800
- 9600
- 19200
- 38400

Select “**YES**” to choose the desired baud rate. The default setting is 9600.

DDC Address

The network address must be entered in accordance with the Instrument Data Sheet, and care must be taken to ensure that the same address is not used anywhere else in the same network. Select “**NO**” for small incremental changes or hold it continuously in that position for larger changes until the required value is displayed. The address may be set at any value between 001 and 250.

⚠ **WARNING:** Each actuator must have a unique address.

Topology

The topology parameter selected depends on the system design. Regardless of which topology setting is used, the actuator field wiring is the same (refer to **Section 3.1.2.1, Network Cable Connection to Field Unit**).

Use the black control knob to select “**NO**”, which toggles the topology setting. The topology options are:

Repeater (Daisy Chain/Loop)

- Field unit connects both Channels A & B to terminal block (dual independent channels)
- Field unit acts as repeater device
- Internal bias & termination is enabled

Multidrop (Single Bus)

- Field unit connects only Channel A to terminal block (single shared channel)
- Field unit does not act as repeater device
- Internal bias & termination is disabled

Select “**YES**” to choose the desired topology. The default setting is Repeater.

Analog Scale

The values of external analog data received over the DDC network may be scaled as shown below to suit the users preference.

Using the black control knob, select “**NO**” until the required scale is displayed. The scale options are as follows:

- 0-100 of span
- 0-255 of span
- 0-4095 of span

The changing of the analog scale will affect all the values in registers 3, 4, 6, 7, 8, 15 and “move-to” commands. Scaling conventions must be consistent between the field unit and host device.

ESD Action

The ESD action parameter determines the action to be taken in the event that the actuator is commanded to initiate an emergency shutdown.

Using the black control knob, select “**NO**” until the desired action is displayed. The action options are:

- STOP
- OPEN
- CLOSE
- IGNORE
- POSITION (0-100%)

Select “**YES**” to choose the desired action. The default setting is IGNORE.

FC 07 Config

The FC 07 config section is used for those host systems that intend to use Poll By Exception (Modbus function code 07) for their process control. For details on how to use this feature, consult **Section 2.3.9, Modbus Function Code 07 (Read Exception Status)**.

Using the black control knob, select “**NO**” until the desired settings are displayed. The options are:

FC 07 Status

- Disables/enables Poll By Exception mode.
- OFF or ON

Register ‘X’ (repeated for Registers 8, 9, 10, 12, and 13)

- Disables/enables which Modbus registers are included in Poll By Exception monitoring.
- OFF or ON

Select “**YES**” to choose the desired settings. By default Poll By Exception mode is OFF.

Combined Fault Warnings

The combined fault warnings parameter can be used to expand the set of hardware faults that will trigger a Combined Fault event to include hardware warnings as well.

Use the black control knob to select “**NO**”, which toggles the combined fault setting ON or OFF. The default setting is OFF.

Proportional & Dead Band

The proportional and dead band parameters are utilized when “move-to” commands are used to drive the actuator to a specific position.

Using the black control knob, select “**NO**” until the desired settings are displayed. The options are:

Proportional Band

- Deviation from target position at which actuator will slow operation speed.
- Range is 1-100% in increments of 1%.

Dead Band

- Deviation from target position at which actuator will cease operation.
- Range is 1-50% in increments of 1%.

Select “**YES**” to choose the desired settings. The default settings are 5% for proportional band, 2% for dead band.

Comm Loss Action

The comm loss action parameter determines the action to be taken in the event that the actuator does not receive a valid Modbus request from the host system within the given delay period (comm loss delay parameter).

Using the black control knob, select “**NO**” until the desired action is displayed. The action options are:

- NONE
- OPEN
- CLOSE
- STOP
- POSITION (0-100%)

Select “**YES**” to choose the desired action. The default setting is NONE.

Comm Loss Delay

The comm loss delay parameter is used as the point of reference for tracking comm loss events on the field unit. This value represents how long the field unit will wait for a valid Modbus request from the host system before declaring a comm loss event.

Use the black control knob to select “**NO**”, which toggles the comm loss delay setting. The delay period may be set to any value between 1 and 120 seconds. Select “**YES**” to choose the desired delay setting. The default setting is 60 seconds.

Standard Digital Inputs (Register 12, Bits 08–13)

The field unit contains six digital inputs for monitoring the status of external contacts. The inputs may be powered one of two ways:

- From the actuator (24 VDC)
- From the customer’s source (24 VDC or 120 VAC)

NOTE: These digital inputs are meaningful only when DDC option is used.

The six standard digital inputs may be configured in a number of ways for monitor and/or control. (See **Table 3.4** and **Table 3.5**.) In any selected configuration, the inputs may be monitored via the DDC-100 network by reading the field unit holding registers 12 (Digital Inputs 1) and 13 (Digital Inputs 2).

The presence of voltage on a terminal will indicate a “TRUE” condition. The absence of voltage will indicate a “FALSE” condition.

Depending on configuration, the host may read the digital input to monitor field-installed devices connected to the DDC input OR may monitor the digital input to verify an actuator function in relation to a preselected condition (ESD, Hardwire Remote Control, Inhibits).

Table 3.4 – DDC digital input configurations (only one selection per row is permitted)

Digital Input Default	Digital Input	Digital Input Options
ESD	User Input 0	Open/Close Inhibit, Both Inhibits, User Defined
Open Inhibit	User Input 1	Open/Close Inhibit, Both Inhibits, User Defined
Close Inhibit	User Input 2	Open/Close Inhibit, Both Inhibits, User Defined, CSE Remote
Three-Wire Inching	User Input 3,4,5	Three-Wire Maintained, Four Wire

Table 3.5 – DDC digital inputs (cross-reference of various inputs)

Terminal #	Basic Function	Digital Input	True Value ¹	False Value	Register . Bit
30	ESD Input (default)	User Input 0	1	0	12 . 08
34	Open Inhibit (default)	User Input 1	1	0	12 . 09
35	Close Inhibit (default)	User Input 2	1	0	12 . 10
26	Stop PB Input	User Input 3	0	1	12 . 11
25	Open PB Input	User Input 4	1	0	12 . 12
27	Close PB Input	User Input 5	1	0	12 . 13

Note 1: True value indicates voltage present at terminal point.

Table 3.6 – Digital input voltages

Terminal #	Minimum "ON"	Maximum "OFF"	Maximum Load	Minimum Signal Duration
25	19.2 VAC/DC	5.0 VAC/DC	10 mA / 110 VAC	350 ms
			2 mA / 24 VDC	
26	19.2 VAC/DC	5.0 VAC/DC	10 mA / 110 VAC	350 ms
			2 mA / 24 VDC	
27	19.2 VAC/DC	5.0 VAC/DC	10 mA / 110 VAC	350 ms
			2 mA / 24 VDC	
30	19.2 VAC/DC	5.0 VAC/DC	10 mA / 110 VAC	350 ms
			2 mA / 24 VDC	
34	19.2 VAC/DC	5.0 VAC/DC	10 mA / 110 VAC	350 ms
			2 mA / 24 VDC	
35	19.2 VAC/DC	5.0 VAC/DC	10 mA / 110 VAC	350 ms
			2 mA / 24 VDC	

Digital Outputs (Register 11, Bits 02 & 03 [S]; Register 11, 02-08, 10 [R])

Four latching digital outputs are provided to control external equipment; S1a, S1b, S2a, S2b as standard. Two contacts may be individually configured for normally open, normally closed, or blinker operation. The remaining two contacts are complementary. These are normally configured to trip when the valve reaches the OPEN and CLOSED positions. However, the configuration may be changed to “**NETWORK CONTROLLED**,” in which case these contacts may be opened and closed over the network. Each of the digital outputs may be configured for one of the following functions:

- Closed
- Closing
- Mid-travel
- Open
- Opening
- Stopped
- Valve moving
- Local selected
- Local STOP/OFF
- Manual operation
- Valve jammed
- Remote selected
- Motor overtemp
- Overtorque
- Open torque switch
- Close torque switch
- ESD signal
- Open inhibit
- Close inhibit
- Lost phase
- No analog signal
- Hardware failure
- Network controlled
- CSE controlled.

See **LMENIM2306, MX Installation and Operation Manual**. Register 11 is used only for status (read-only).

When the optional relay board is supplied and the relays are enabled, up to eight latching relays may be monitored or controlled. (See **Table 3.7**).

NOTE: Digital outputs must have corresponding digital feedback (digital input) to verify digital output position.

Table 3.7 – DDC digital outputs S1-2 and R1-8

Digital Output	Terminals	Default Config.	Register . Bit
S1	44, 45 (N.O.) 48, 49 (N.C.)	Closed	11.02
S2	50, 51 (N.O.) 46, 47 (N.C.)	Open	11.03
R1 (opt.)	44,45	Closed	11.02
R2 (opt.)	46, 47	Open	11.03
R3 (opt.)	48,49	Closed	11.04
R4 (opt.)	50, 51	Open	11.05
R5 (opt.)	36, 37	Motor Overtemp	11.06
R6 (opt.)	38, 39	Remote Selected	11.07
R7 (opt.)	40, 41	Overtorque	11.08
R8 (opt.)	42, 43	Analog Input Lost	11.10

3.3.2 Configuring RS-485 to Ethernet Adapter Parameters

Make sure the jumpers on the RS-485 to Ethernet adapter are set correctly. The jumps between pins 1 & 2 and pins 4 & 5 on X1 should be made to support Modbus TCP/IP operation.

Figure 3.13 - Jumper on RS-485 to Ethernet adapter



Enter the configuration menu of the RS-485 to Ethernet adapter through the web (Ethernet) interface. The default TCP/IP address is 192.168.100.1. This TCP/IP address can be typed directly into a web browser to access the adapter. There is no default user name or password (can be added by the user later) so just click “**Log In**” to bypass the login dialog and arrive at the configuration home page.

Figure 3.14 - Web interface login

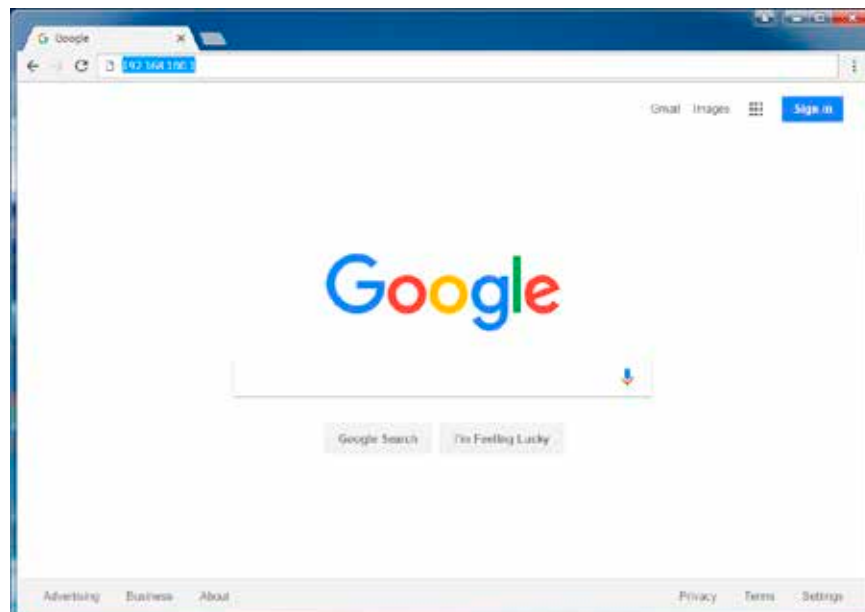

Navigate to the **“Serial Settings”** page using the menu bar on the left-hand side of the page. Using the controls provided, set the serial parameters of the adapter to match the Modbus network settings. The default serial settings are RS-485 2 wire interface, Modbus RTU protocol, 9600 baud, 8 data bits, no parity, 1 stop bit. The values of the timing parameters (character timeout, message timeout) are dependent on the network topology and should be tuned accordingly. Be sure to select the **“OK”** button to commit the changes.

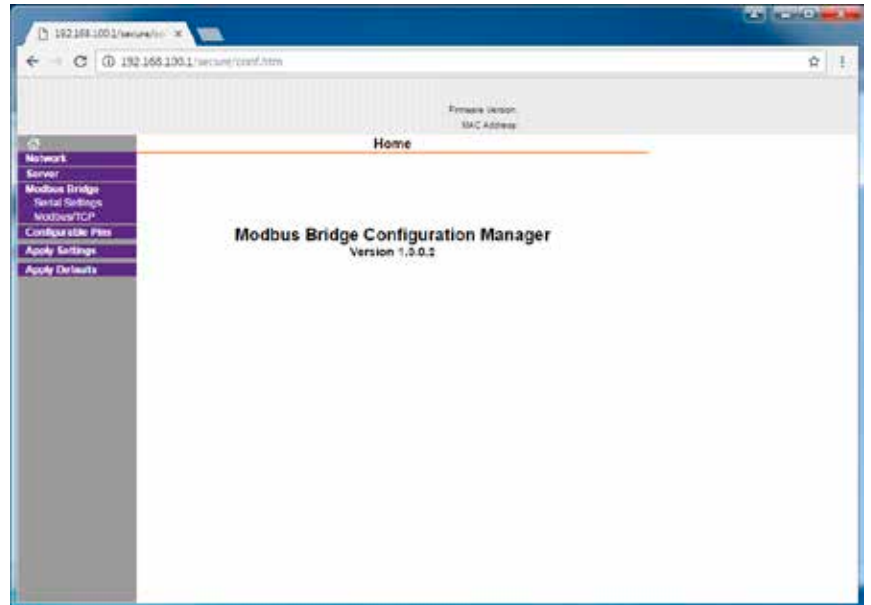

Figure 3.15 - Web interface home screen

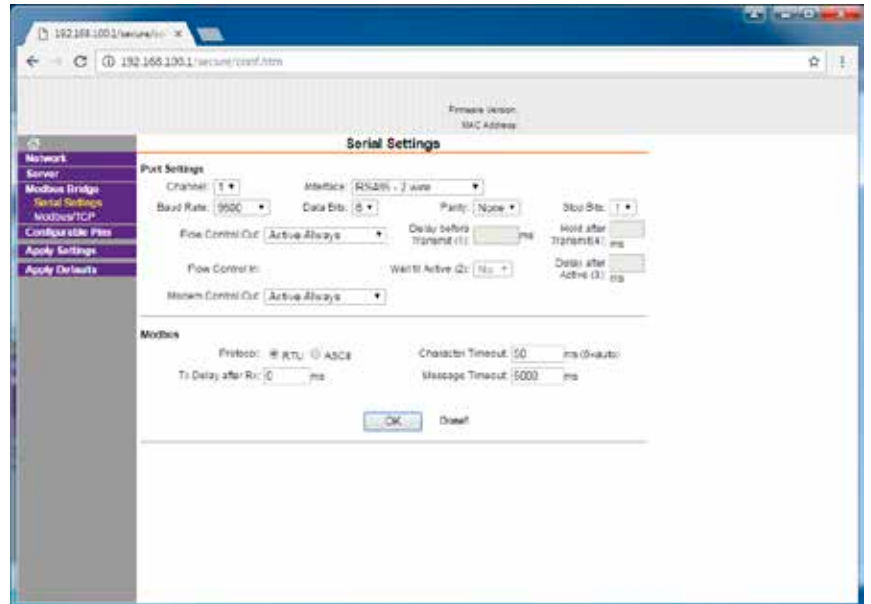

Figure 3.16 - Web interface Serial Settings setup

Navigate to the “**Network**” page using the menu bar on the left-hand side of the page. Using the controls provided, assign the desired TCP/IP address, subnet mask, and default gateway settings to the adapter. The default network settings are static IP configuration, 192.168.100.1 TCP/IP address, 255.255.255.0 subnet mask, 192.168.100.254 default gateway. The TCP/IP address can be set manually or retrieved automatically from a DHCP server. Be sure to select the “**OK**” button to commit the changes. When setup as a gateway device, the TCP/IP address will act as the shared point of contact for all actuators on the attached RS-485 bus. If setup as a slave device, the TCP/IP address will be unique to the actuator that the adapter is installed in.

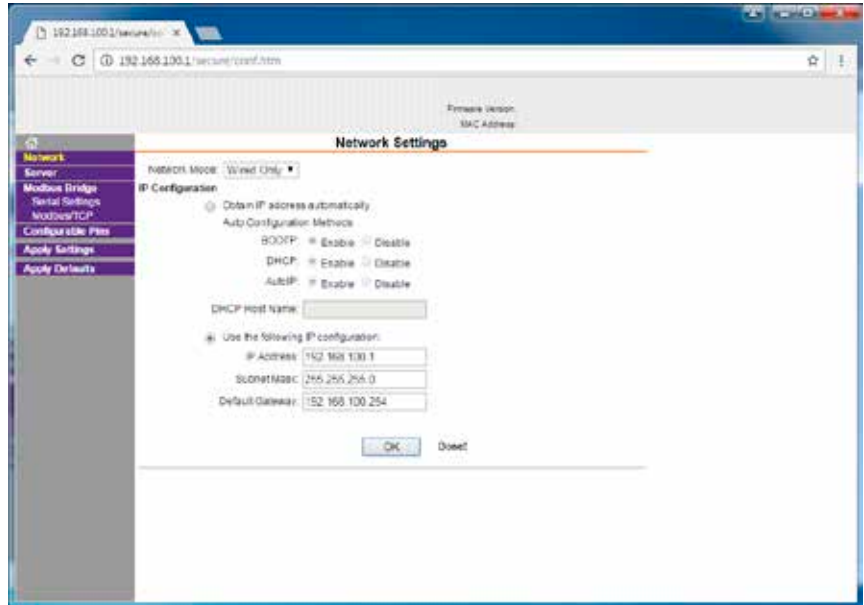

Figure 3.17 - Web interface Network setup

After reviewing all of the adapter settings for correctness, select the “**Apply Settings**” option from the menu bar on the left-hand side of the page. The adapter will require several seconds to commit the configuration to non-volatile memory and reboot.

Note that the Modbus address (range of 1-250) of the target actuator (as configured through the LCS) must be included within each Modbus TCP/IP request sent from the host.

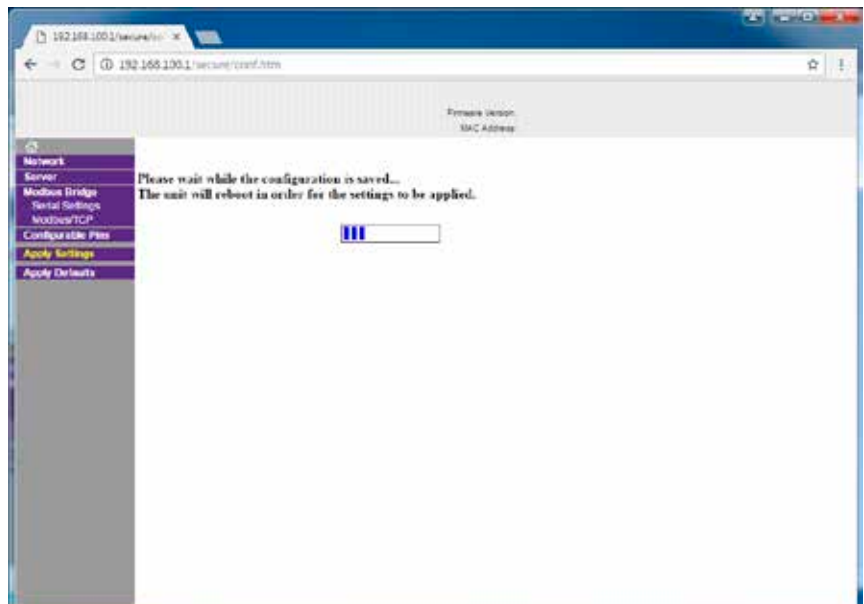

Figure 3.18 - Web interface Apply Settings

3.4 Configuration Confirmation

Field unit operation cannot be verified until the complete DDC-100 system is operational. However, routine checks can be performed to verify many functions.

3.4.1 Checking Connections

Verify that all connections, including data wires, shield ground, digital inputs (optional), digital outputs (optional), and analog inputs (optional) are in accordance with wiring diagrams and field unit diagrams in **Section 3.1.2, Network Cable Preparation**.

3.4.2 View Settings

Refer to **LMENIM2306, MX Installation and Operation Manual** to access the “**VIEW SETTINGS**” menu. Verify the settings as follows:

1. Confirm the DDC status is ON.
2. Confirm the address for each field unit is correct and unique.
3. Confirm the protocol, baud rate, parity & stop bits are correct.
4. If the relay contacts are to be used to control external equipment, verify that each of the digital outputs is set for “**NETWORK CONTROLLED**” in the “**VIEW STATUS AND ALARM CONTACTS**” menu (refer to **Table 3.7**).

3.4.3 Checking the Normal Display

Place the selector switch in “**LOCAL**” or “**REMOTE**” position. The valve position will be indicated at the top of the LCD. “**STATUS OK**” or “**DDC COMM LOSS**” should be indicated at the bottom of the LCD display.

- If “**STATUS OK**” is displayed, the field unit is communicating with the host/Master Station.
- If “**DDC COMM LOSS**” is displayed, no communication is occurring. This could be due to a number of factors, including problems with the host system (Master Station) and/or network. Check all local connections and configurations. Confirm that the host is connected, configured to match DDC parameters of field units, and operational. See also **Section 5, Troubleshooting**.

3.19 - Error messages

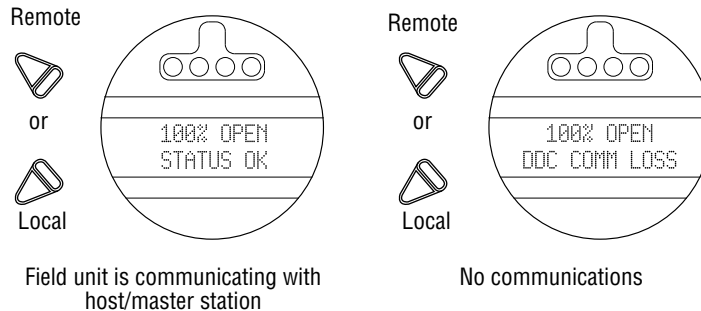

4 Associated Documents

MX Actuator	
Quick Start-Up Instructions (MX Actuators)	Limitorque Bulletin FCD LMENIM2310
MX Installation and Operation Manual	Limitorque Bulletin FCD LMENIM2306
MX Maintenance and Spare Parts Manual	Limitorque Bulletin FCD LMENIM2314
MX Dashboard Manual	Limitorque Bulletin FCD LMENIM2338

QX/QXM Actuators	
Quick Start-Up Instructions (QX Actuators)	Limitorque Bulletin FCD LMENIM3313
QX Installation and Operation Manual	Limitorque Bulletin FCD LMENIM3306
QX Maintenance and Spare Parts Manual	Limitorque Bulletin FCD LMENIM3314
QX Dashboard Manual	Limitorque Bulletin FCD LMENIM2338

Master Station	
Master Station Installation and Operation Manual	Limitorque Bulletin FCD LMENIM5001

5 Troubleshooting

1. Refer to **Appendix A, Wiring Diagram**.
 2. With power off and network disconnected, verify continuity between A1, A2 and A1*, A2*.
 3. With power applied and network disconnected, verify 0.2 to 0.45 VDC between A1, A1* and A2, A2*.
 4. Confirm that a jumper cable is installed between the grounding lug and terminal 3.
 5. Verify proper setup for DDC.
 - ESD must be configured for desired function and properly wired.
 - OPEN INHIBIT must be configured for desired function and properly wired.
 - CLOSE INHIBIT must be configured for desired function and properly wired.
 - Remote four-wire control is not selected if not in use, or properly wired if selected.
 6. Confirm there are no duplicate DDC addresses.
 7. Confirm that each network segment is grounded at one end only.
 8. Confirm protocol, baud rate, parity & stop bits match for all devices on the network.
- Example: Field Unit 1 - 9600, Modbus, RTU, 8,1,N
 Field Unit 2 - 9600, Modbus, ASCII, 8,1,N
 Confirm error and correct
 Field Unit N - 9600, Modbus, RTU, 8,1,N
9. Confirm that host controller allows sufficient timeout periods (at least 200 ms).
 Confirm that host controller allows at least one message retry before declaring loss of communication.
 10. Main power supply must be within +/-10% of nominal unit power rating at all times. Refer to nameplate for voltage.
 11. UPS of 24 VDC must be within +/-10% at all times.
 12. Workmanship:
 - The MX is non-intrusive which facilitates ease of configuration without removal of the controls cover. Removal of the controls cover without permission from Flowserve can void the warranty.
 - Practice all plant and safety codes and standards. Failure to follow instructions can result in personal injury and/or property damage.
 - Do NOT remove covers of Division 1 units with power applied to prevent the possible ignition of hazardous atmospheres.
 - All servicing should be performed by qualified technicians. Dangerous voltages may be present on the circuit boards and terminations.
 - Use extreme caution when working around power input cables. These cables have potentially lethal voltages on them.
 - Replace fuses only with specified parts for continued safe operation.
 - Have qualified personnel verify all wiring and connections against vendor drawings prior to energizing the equipment. Incorrect wiring and/or connections can result in equipment damage.

NOTE: Removal of control cover and replacement of control boards must be performed by authorized Flowserve Limitorque service personnel only. Consult a Flowserve Limitorque service coordinator at (434) 528-4400.

▲ CAUTION: There is potential to cause electrostatic damage to electronic components. Before handling electronic components, ensure that you are discharged of static electricity by briefly touching a grounded metal object.

The circuit boards in the DDC-100 contain components that are subject to damage from electrostatic discharge (static electricity). The following precautions and procedures are recommended when handling circuit boards and components. Failure to observe these practices when handling and shipping circuit board products may void your warranty.

- Keep plastics and other materials prone to the buildup of electrostatic charges (static electricity) away from boards, components, and work area.
- Avoid synthetic or wool clothing; wear cotton or cotton blend materials. Keep components and circuit boards away from clothing and hair.
- Discharge static electricity on your body by touching and momentarily holding a grounded metal object before handling electronic components. This is especially important after walking across carpeted areas.
- Handle components in the field as little as necessary.
- Handle components only by the edges, and avoid contact with leads, circuits, or connectors.
- Do not touch the surface of the printed circuit board, the connectors, or the components with conductive devices or with your hands.
- Always place the component or board into an anti-static protective bag for transportation or storage.
- Transport all static-sensitive components only in static-shielding carriers or packages. Place static awareness labels on all components to prevent removal from static-shielding container during transit.
- Handle all static-sensitive components at a static-safe work area including floor mat, wrist strap, air ionizer, ground cord, and conductive table mat.
- Do not subject components to sliding movements over any surface, at any time.

6

How to Order Parts

To order parts or obtain further information about your Flowserve Limitorque DDC-100 field unit, contact your local Flowserve distributor sales office, or:

Flowserve Corporation

Limitorque Actuation Systems
5114 Woodall Road
P.O. Box 11318
Lynchburg, VA 24506-1318

Phone (434) 528-4400

Fax (434) 845-9736

To find the Flowserve Limitorque distributor or sales office near you, go to <http://www.flowserve.com>.

All inquiries or orders must be accompanied by the following information supplied on the actuator nameplate:

1. Unit size
2. Order number
3. Serial number

A

Appendix – Wiring Diagram

Figure A.1 (1 of 2) – Typical DDC-100 wiring diagram

TYPE	TAPS	APPL. VOLTAGES	TYPE	TAPS	APPL. VOLTAGES	TYPE	TAPS	APPL. VOLTAGES
1	106 V	110 V	2	226 V	226 V, 260 V, 240 V	3	212 V	220 V
	115 V	115 V, 120 V		366 V	380 V		505 V	525 V
	200 V	208 V		392 V	400 V, 415 V		530 V	550 V
	220 V	220 V		450 V	440 V, 460 V, 480 V		572 V	575 V, 600 V

NOTE: (SEE INSTALLATION & OPERATION MANUAL FOR DETAILS – LMENIM2306)

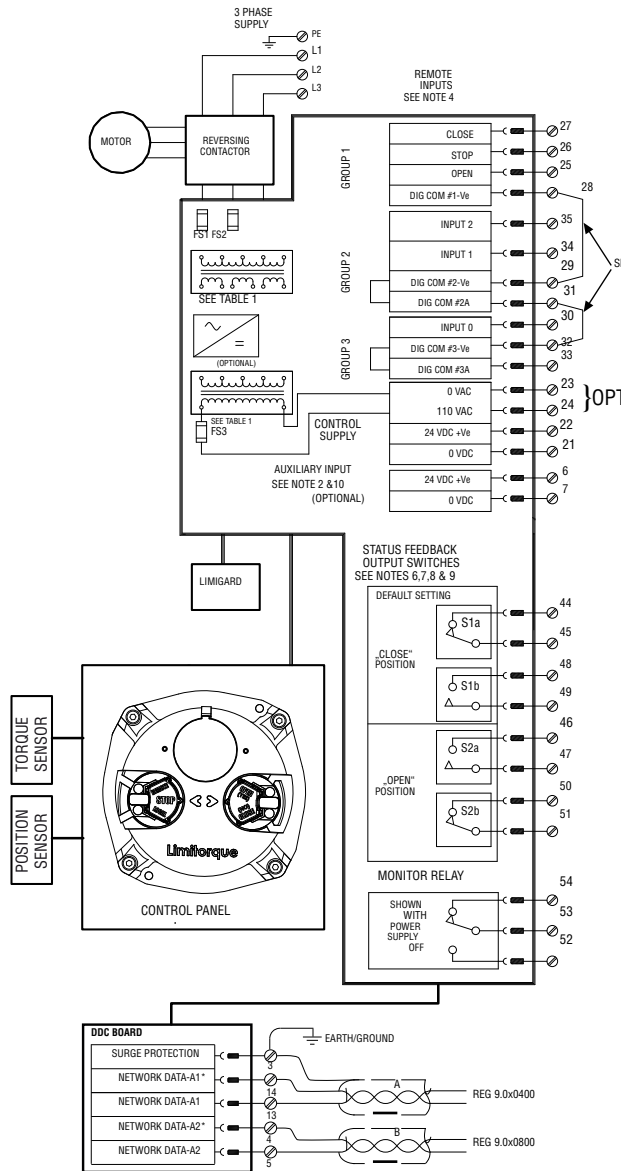

- FUSES**
 - FS1 (PRIMARY) } 600 VAC, 1 A, 200 kA Int RATING, FAST ACTING 10.3 x 38.1 mm TUBE.
 - FS2 (PRIMARY) }
 - FS3 (SECONDARY) - 0.1 A, 250 V, TIME DELAY, 5 x 20 mm, GLASS TUBE
- AUXILIARY INPUT (OPTIONAL W/ BACKUP POWER BOARD) BACK-UP**

24 VDC UPS POWER MAY BE CONNECTED TO TERMINALS 6 AND 7. MAXIMUM CURRENT DRAW IS 1 AMP. THIS POWERS ALL CONTROLS FOR LOCAL INDICATION AND CONFIGURATION. REVERSING CONTACTOR WILL NOT BE POWERED. CUSTOMER MUST SUPPLY EXTERNAL FUSE AS REQUIRED BY LOCAL ELECTRICAL CODES.
- MAXIMUM EXTERNAL LOAD TERMINALS 21 AND 22 (24 VDC) - 5 W MAX. EXT. LOAD**

TERMINALS 23 AND 24 (OPT. 110 VAC) - 20 W MAX EXT. LOAD, 15 VA
- REMOTE INPUTS**

SIGNAL THRESHOLD - MINIMUM „ON“ 19.2 VAC/VDC
 MAXIMUM „OFF“ 5.0 VAC/VDC
 MAX LOAD - 10 mA / 110 VAC
 2 mA / 24 VDC
 REQUIRED CONTROL SIGNAL DURATION = 350 ms MIN.

INPUTS 0,1,2 ARE FIELD CONFIGURABLE FOR CLOSE/OPEN INHIBIT, REDUNDANT OPEN, CLOSE, STOP [LIMIGARD] USER INPUT OR ESD. IN ADDITION, INPUT 0 MAY BE CONFIGURED FOR CLOSE; INPUT 1 MAY BE CONFIGURED FOR STOP; INPUT 2 MAY BE CONFIGURED FOR CSE. REMOTE SELECTION INDICATION: DEFAULT INPUT CONFIGURATION: INPUT 0 - ESD, INPUT 1 - OPEN INHIBIT, INPUT 2 - CLOSE INHIBIT
- REMOTE INPUT JUMPERS**

JUMPERS ARE USER WIRED TO CONNECT DIG COMMONS #1, 2 & 3 (AS NEEDED).
- STATUS FEEDBACK OUTPUT SWITCHES THE ACTUATOR STATUS CONTACTS (S1 & S2) MAY BE INDIVIDUALLY CONFIGURED AS NORMALLY OPEN OR NORMALLY CLOSED LATCHED CONTACTS, OR AS BLINKER CONTACTS, TO INDICATE ONE OF THE FUNCTIONS LISTED BELOW:**

CLOSE	VALVE JAMMED
CLOSING	MOTOR OVERTEMP
MID-TRAVEL	OVERTORQUE
OPENING	OPEN TORQUE SW
OPEN	CLOSE TORQUE SW
STOPPED	CLOSE INHIBIT
VALVE MOVING	OPEN INHIBIT
LOCAL SELECTED	ESD SIGNAL
LOCAL STOP/OFF	ANALOG IP LOST
MANUAL OVERRIDE	LOST PHASE
REMOTE SELECTED	LIMIGARD ACTIVE
CSE CONTROL	HARDWARE FAILURE
	NETWORK CONTROLLED
- CONTACT RATINGS**

S1, S2 - 0.5 A @ 125 VAC, 2 A @ 30 VDC (RESISTIVE)
 MONITOR - 0.5 A @ 125 VAC, 2 A @ 30 VDC (RESISTIVE)
- EXACT END POSITION INDICATION ON TORQUE-SEATED VALVES THE LCD AND „S“ CONTACTS, CONFIGURED AS END OF TRAVEL LIMITS, AUTOMATICALLY PROVIDE EXACT END OF POSITION INDICATION.**
- DEFAULT [S] SETTING**

THE DEFAULT OPERATING CONFIGURATION FOR THE „S“ OUTPUTS ARE SHOWN IN THE TABLE BELOW. THE CONTACT STATES SHOWN IN THE SCHEMATIC REPRESENT A FULLY CLOSED VALVE.

DIGITAL OUTPUTS
 THE DIGITAL OUTPUTS (S) MAY BE INDIVIDUALLY CONFIGURED AS OPEN OR CLOSE LATCHED, OR AS BLINKER CONTACTS. S1a, S1b, S2a, S2b, MAY ALSO BE "DDC CONTROLLED" FROM MASTER STATION.

OUTPUT SWITCH	VALVE POSITION		FUNCTION
	FULL CLOSE	FULL OPEN	
S1a	—	—	CLOSE LIMIT
S1b	—	—	
S2a	—	—	OPEN LIMIT
S2b	—	—	

LEGEND
 — — — OPEN CONTACT
 — — — CLOSED CONTACT

S1a & S1b HAVE COMPLEMENTARY LOGIC
 S2a & S2b HAVE COMPLEMENTARY LOGIC

Figure A.1 (2 of 2) – Typical DDC-100 wiring diagram

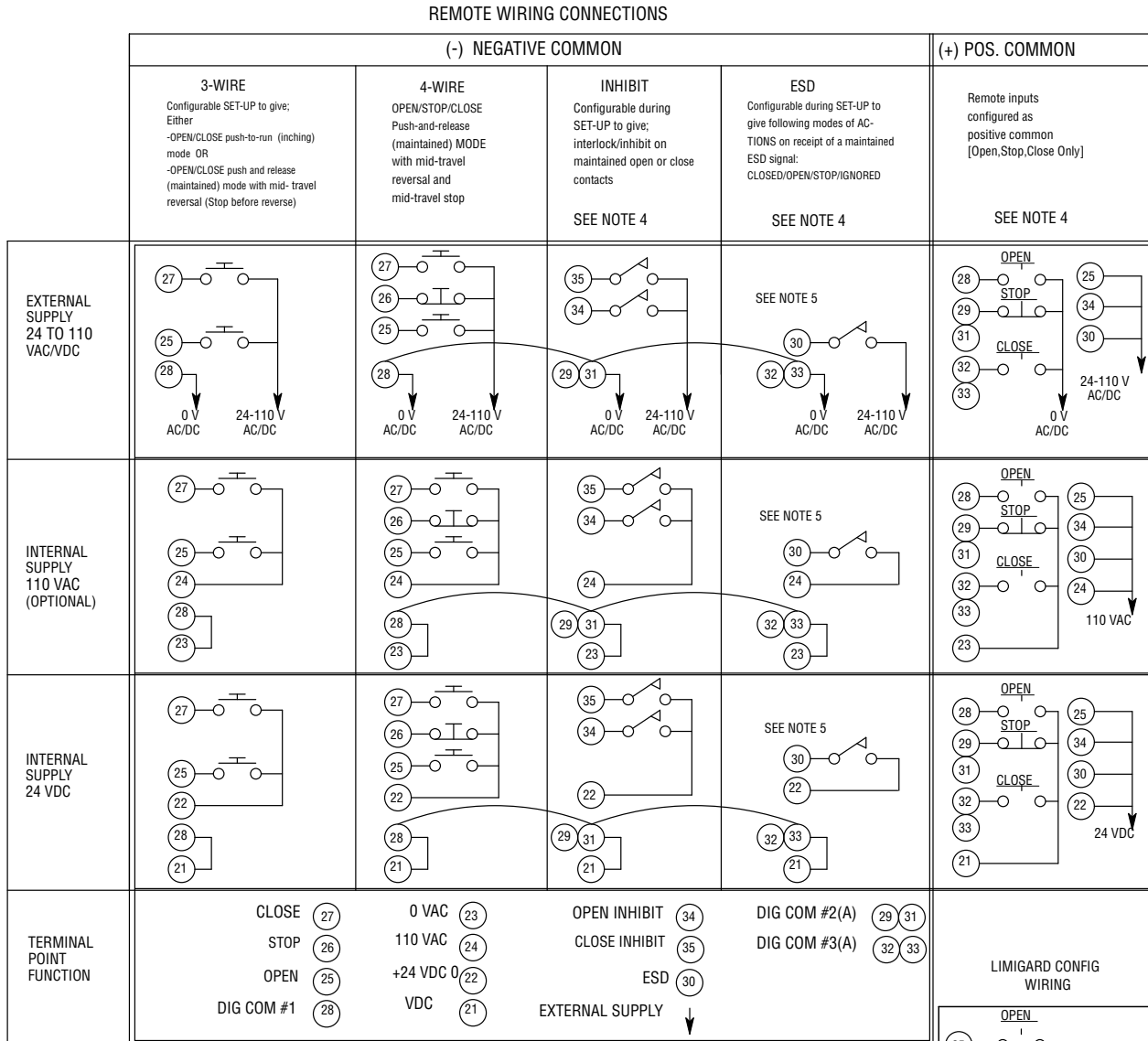

- NOTES:**
- THE 3 REMOTE WIRING GROUPS ARE ELECTRICALLY ISOLATED INTERNALLY. SINGLE OR MULTIPLE POWER SOURCES MAY BE SELECTED TO INDIVIDUALLY POWER EACH GROUP. IF MULTIPLE SOURCES ARE USED, ENSURE THAT POLARITIES ARE CORRECT.
 - ONLY A SINGLE POWER SOURCE MAY POWER ANY ONE GROUP.
 - COMMONS MAY BE CONNECTED TOGETHER AS NEEDED.
 - REMOTE INPUTS SIGNAL THRESHOLD
MINIMUM "ON" 19.2 VAC/DC
MAXIMUM "OFF" 5.0 VAC/DC
MAX LOAD - 10 mA / 110 VAC
2 mA / 24 VDC
 - COMMAND PRIORITY
MODUTRONIC COMMAND WILL OVERRIDE 3 AND 4 WIRE COMMANDS.
INHIBIT AND ESD SIGNALS WILL OVERRIDE MODUTRONIC COMMANDS.

Figure A.2 - Terminal block

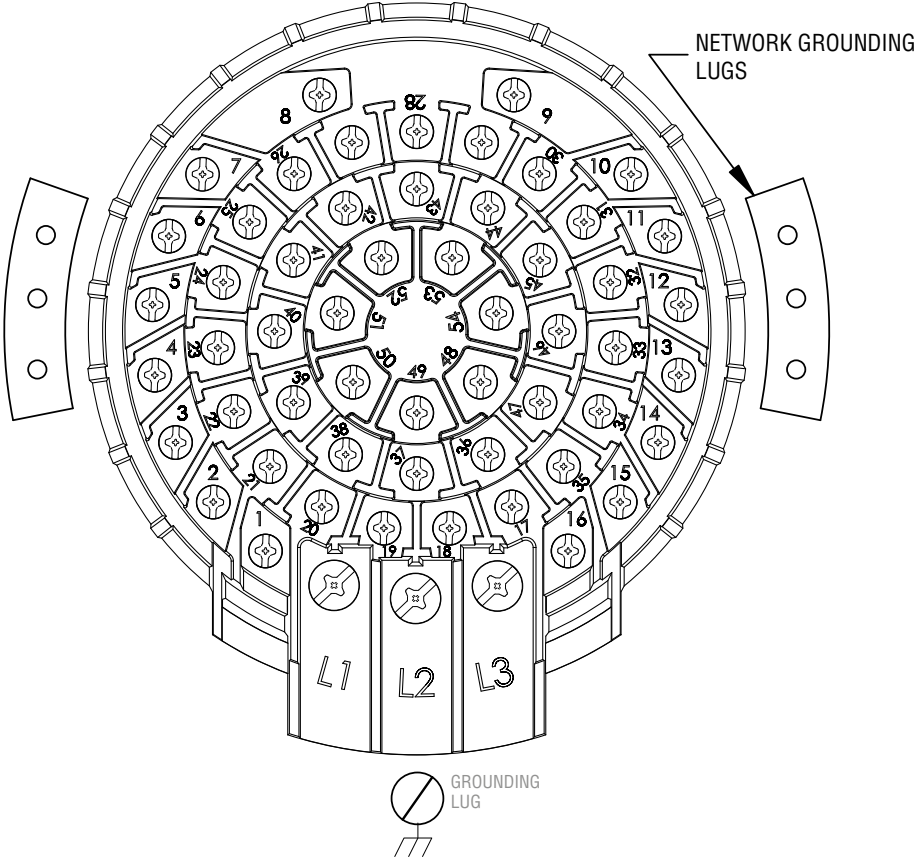

B Appendix – DDC Register Definitions

Register 1

Command register. Write-only. 16-bit unsigned value. Control register for input of predetermined actuator control values. Typical values equate to Open, Stop, Close, “Move-To”, etc.

Register 2

Argument register. Write-only. 16-bit unsigned value. Control register for input of variable data used for predefined actuator control scenarios. Typical usage is for input of desired valve position when used with the “move-to” command.

Register 3

Analog Out 1. Read-only. 16-bit unsigned value. This option may be configured for APT or ATT and MUST be present and enabled for a value to be displayed in this register. Reports the a 4-20 mA / 0-20 mA / 0-10 VDC / 2-10 VDC / 1-5 VDC / 0-5 VDC output signal value as configured in 0-100 increments of span. May be adjusted to different scaling of 0-255 or 0-4095. The analog output signal is referenced at terminal points 18 and 17 (common).

Scaling chosen through **Analog Scale** parameter within the DDC configuration (see **Section 3.3.1.2 Changing DDC Parameters**).

Register 4

Analog Out 2 value. Read-only. 16-bit unsigned value. This option may be configured for APT or ATT and MUST be present and enabled for a value to be displayed in this register. Reports a 4-20 mA / 0-20 mA / 0-10 VDC / 2-10 VDC / 1-5 VDC / 0-5 VDC output signal value as configured in 0-100 increments of span. May be adjusted to different scalings of 0-255 or 0-4095. The analog output signal is referenced at terminal points 16 and 1 (common).

Scaling chosen through **Analog Scale** parameter within the DDC configuration (see **Section 3.3.1.2 Changing DDC Parameters**).

Register 5

Indicates measured voltage of three-phase power. 16-bit unsigned value. Provides information for diagnostic purposes.

Register 6

Analog Input 1. Read-only. 16-bit unsigned value. May be configured to record a 4-20 mA or 0-20 mA signal. Default scale is 0-100 increments of span. May be adjusted to different scaling of 0-255 or 0-4095. Referenced as terminals 12 and 17 (common).

Scaling chosen through **Analog Scale** parameter within the DDC configuration (see **Section 3.3.1.2 Changing DDC Parameters**).

Register 7

Analog Input 2. Read-only. 16-bit unsigned value. May be configured to record a 4-20 mA or 0-20 mA signal. Default scale is 0-100 increments of span. May be adjusted to different scaling of 0-255 or 0-4095. Referenced as terminals 2 and 1 (common).

Scaling chosen through **Analog Scale** parameter within the DDC configuration (see **Section 3.3.1.2 Changing DDC Parameters**).

Register 8

Position register. Read-only. 16-bit unsigned value. Default scale is 0-100 increments of open. May be adjusted to different scaling of 0-255 or 0-4095.

Scaling chosen through **Analog Scale** parameter within the DDC configuration (see **Section 3.3.1.2 Changing DDC Parameters**).

Register 9

Status register. Read-only. 16-bit unsigned value. Contains most desired indications of field unit status. This register is a MUST in controlling a field unit.

Bit 00 Open – Valve is fully opened. This bit is ORd with bits 01, 02, 03, 04. Value of 1=True, Value of 0=False.

Bit 01 Close – Valve is fully closed. This bit is ORd with bits 00, 02, 03, 04. Value of 1=True, Value of 0=False.

Bit 02 Stopped in Mid-Travel - Valve stopped in mid-travel. This bit indicates neither the Open or Close Limit Switch is engaged. This bit is ORd with bits 00, 01, 03, 04. Value of 1=True, Value of 0=False.

Bit 03 Opening – Valve traveling in the Open direction. This bit is ORd with bits 00, 01, 02, 04. Value of 1=True, Value of 0=False.

Bit 04 Closing – Valve traveling in the Close direction. This bit is ORd with bits 00, 01, 02, 03. Value of 1=True, Value of 0=False.

Bit 05 Valve Jammed – Valve is jammed. This bit indicates the valve was traveling or attempting to travel in either the Open or Close direction and has tripped the torque switch. This bit is ONLY active should the actuator be commanded to move locally or remotely and an overtorque condition occurs. Value of 1=True, Value of 0=False.

Bit 06 Not in Remote – Monitors the actuator LCS. Indicates the LCS has been switched to the Local or Stop position. The host will not be able to control the actuator. Value of 1=True, Value of 0=False.

Bit 07 Combined Fault – The combined fault bit indicates there is a severe problem with the field unit. When this bit is TRUE, the actuator must be considered “OFFLINE.” This bit indicates a fault when both bits (10 and 11) are TRUE or bit 5 or bit 8, or bit 9, or bit 15 is TRUE. Value of 1=True, Value of 0=False.

Bit 08 Thermal Overload Fault – Indicates the motor has overheated and the thermistor has opened. This unit is unable to operate and time is required for the motor to cool and reset the thermistor. Value of 1=True, Value of 0=False.

Bit 09 Knob in Stop - Monitors the actuator LCS. Indicates the LCS has been switched to the Stop position. The host will not be able to control the actuator. Value of 1=True, Value of 0=False.

Bit 10 Channel A Fail – Indicates field unit has stopped communicating on network Channel A (A1). Monitors communication on terminal points 13 and 14. Value of 1=True, Value of 0=False.

Bit 11 Channel B Fail – Indicates field unit has stopped communicating on network Channel B (A2). Monitors communication on terminal points 5 and 4. Value of 1=True, Value of 0=False.

Bit 12 Open Torque Switch Fault – Indicates an overtorque condition while traveling in the open direction. The actuator will not move in the open direction again unless the actuator is first moved toward the close position. Torque switch is not set when a normal torque out occurs at the torque limit. Value of 1=True, Value of 0=False.

Bit 13 Close Torque Switch Fault – Indicates an overtorque condition while traveling in the close direction. The actuator will not move in the close direction again unless the actuator is first moved toward the open position. Torque switch is not set when a normal torque out occurs at the torque limit. Value of 1=True, Value of 0=False.

Bit 14 Valve Manually Moved – Indicates the valve position has been changed by stroking the valve with the actuator handwheel (actuator drive sleeve has rotated without motorized operation). Value of 1=True, Value of 0=False.

Bit 15 Phase Error – Indicates loss of phase for the 3-phase power. Value of 1=True, Value of 0=False.

Register 10

Fault register. Read-only. 16-bit unsigned value. Contains additional field unit status. This register is optional for controlling a field unit.

Bit 00 Open Inhibit Active – Indicates field unit has been issued an open inhibit command. Value of 1=True, Value of 0=False.

Bit 01 Close Inhibit Active – Indicates field unit has been issued a close inhibit command. Value of 1=True, Value of 0=False.

Bit 02 Not Used

Bit 03 Not Used

Bit 04 Phase(s) Missing Fault – Indicates one or more phase(s) is absent for the three-phase power. Value of 1=True, Value of 0=False.

Bit 05 Phase Reversed Fault – Indicates field unit has noticed incorrect phase rotation of the incoming power. Value of 1=True, Value of 0=False.

Bit 06 ESD Conflict – Indicates ESD mismatch has occurred. Event with highest configured priority will be initiated. Value of 1=True, Value of 0=False.

Bit 07 Inhibit Conflict – Indicates inhibit mismatch has occurred. Value of 1=True, Value of 0=False.

Bit 08 CSE in Local / Stop – Indicates remote control station is in Local or Stop. Input must be set for CSE and also enabled. Value of 1=True, Value of 0=False.

Bit 09 Not Used

Bit 10 Network ESD is ON – Indicates field unit has been issued a network ESD command. The field unit will command the actuator to operate to the preconfigured position (Open, Close, Stop, Ignore, Position). The network ESD command must be terminated to reset this bit. Value of 1=True, Value of 0=False.

Bit 11 Local ESD is ON – Indicates field unit has been issued a local ESD command. The field unit will command the actuator to operate to the preconfigured position (Open, Close, Stop, Ignore, Position). The local ESD command must be terminated to reset this bit. Value of 1=True, Value of 0=False.

Bit 12 Unit Reset Since Last Poll – Indicates field unit has reset since the last network poll. This bit is latched until read by the host controller. Value of 1=True, Value of 0=False.

Bit 13 In Stop Mode – Monitors the actuator LCS. Indicates the actuator LCS has been switched to the Stop position. The host will not have control of the actuator. Value of 1=True, Value of 0=False.

Bit 14 Opening in Local Mode – Monitors the actuator LCS. Indicates the actuator LCS has been switched to the Local position AND the actuator is being opened via the LCS. The host will not have control of the actuator. Value of 1=True, Value of 0=False.

Bit 15 Closing in Local Mode – Monitors the actuator LCS. Indicates the actuator LCS has been switched to the Local position AND the actuator is being closed via the LCS. The host will not have control of the actuator. Value of 1=True, Value of 0=False.

Register 11

Digital Outputs register. Read-only. 16-bit unsigned value. Contains additional field unit status. This register is optional for controlling a field unit.

Bit 00 Close – Indicates field unit close contactor is engaged and the valve is moving in the close direction. This bit is ORd with Register 11, bit 01. Value of 1=True, Value of 0=False.

Bit 01 Open – Indicates field unit open contactor is engaged and the valve is moving in the open direction. This bit is ORd with Register 11, bit 00. Value of 1=True, Value of 0=False.

Bit 02 Digital Output S1 or R1 – Indicates field unit S1 Relay or R1 Relay (supplied w/ optional relay board) has been energized. S1 is a latched relay w/ two complementary contacts (S1a and S1b), while R1 is an optional latched relay w/ one contact (R1). This relay is configurable to operate under many conditions including network control. Verify current configuration via the LCS. These latched digital output contacts are referenced as terminal points 44 and 45 (S1a / R1), and 48 and 49 (S1b).

Bit 03 Digital Output S2 or R2 – Indicates field unit S2 Relay or R2 Relay (supplied w/ optional relay board) has been energized. S2 is a latched relay w/ two complementary contacts (S2a and S2b), while R2 is an optional latched relay w/ one contact (R2). This relay is configurable to operate under many conditions including network control. Verify current configuration via the LCS. These latched digital output contacts are referenced as terminal points 46 and 47 (S2a), 50 and 51 (S2b), and 48 and 49 (R2).

Bit 04 Digital Output R3 – Optional relay board required. Indicates the optional field unit R3 Relay has been energized. This relay is configurable to operate under many conditions including network control. Verify current configuration via the LCS. This latched digital output contact is referenced as terminal points 46 and 47.

Bit 05 Digital Output R4 – Optional relay board required. Indicates the optional field unit R4 Relay has been energized. This relay is configurable to operate under many conditions including network control. Verify current configuration via the LCS. This latched digital output contact is referenced as terminal points 50 and 51.

Bit 06 Digital Output R5 – Optional relay board required. Indicates the optional field unit R5 Relay has been energized. This relay is configurable to operate under many conditions including network control. Verify current configuration via the LCS. This latched digital output contact is referenced as terminal points 36 and 37.

Bit 07 Digital Output R6 – Optional relay board required. Indicates the optional field unit R6 Relay has been energized. This relay is configurable to operate under many conditions including network control. Verify current configuration via the LCS. This latched digital output contact is referenced as terminal points 38 and 39.

Bit 08 Digital Output R7 – Optional relay board required. Indicates the optional field unit R7 Relay has been energized. This relay is configurable to operate under many conditions including network control. Verify current configuration via the LCS. This latched digital output contact is referenced as terminal points 40 and 41.

Bit 09 Network Bypass Relay – Indicates the network bypass relay is energized. Should this relay be de-energized, the actuator will fail to communicate with the host. Value of 1=True, Value of 0=False.

Bit 10 Digital Output R8 – Optional relay board required. Indicates the optional field unit R8 Relay has been energized. This relay is configurable to operate under many conditions including network control. Verify current configuration via the LCS. This latched digital output contact is referenced as terminal points 40 and 41.

Bit 11 Not Used

Bit 12-15 MOV Series Identification - Indicates the actuator type. Value of 0=UEC, Value of 1=MX, Value of 6=QX, Value of 9=MXa, Value of 10=UEX, Value of 11=QXM.

Register 12

Digital Inputs 1 register. Read-only. 16-bit unsigned value. Contains field unit status and digital input status.

Bit 00 Knob in Remote – Monitors the actuator LCS. Indicates the LCS has been switched to the Remote position. The host is in control of the actuator. Value of 1=True, Value of 0=False.

Bit 01 Thermal Overload Fault – Indicates the motor has overheated and the thermistor has opened. This unit is unable to operate and time is required for the motor to cool and reset the thermistor. Value of 1=True, Value of 0=False.

Bit 02 Open Torque Switch – Indicates an overtorque condition while traveling in the open direction. This condition will also be true if the actuator is 100% open and torque-seated. Value of 1=True, Value of 0=False.

Bit 03 Open Limit Switch – Open limit switch is engaged. Valve is fully opened. Value of 1=True, Value of 0=False.

Bit 04 Close Torque Switch – Indicates an overtorque condition while traveling in the close direction. This condition will also be true if the actuator is 0% open and torque-seated. Value of 1=True, Value of 0=False.

Bit 05 Close Limit Switch – Close limit switch is engaged. Valve is fully closed. Value of 1=True, Value of 0=False.

Bit 06 Analog Input 2 Lost – Indicates optional analog input 2 is not receiving a 4-20mA signal. Referenced as Terminals 2 and 1 (common). Value of 1=True, Value of 0=False.

Bit 07 Quik Board Present – Indicates optional backup power board is present. Value of 1=True, Value of 0=False.

Bit 08 User Input 0 – User Input 0 setting is configurable (factory default is ESD). Referenced as Terminal 30. Connect with 120 VAC or 24 VDC. Minimum ON voltage 19.2 VAC/DC; maximum OFF voltage 5.0 VAC/DC. Value of 1=True/ON, Value of 0=False/OFF.

Bit 09 User Input 1 – User Input 1 setting is configurable (factory default is Open Inhibit). Referenced as Terminal 34. Connect with 120 VAC or 24 VDC. Minimum ON voltage 19.2 VAC/DC; maximum OFF voltage 5.0 VAC/DC. Value of 1=True/ON, Value of 0=False/OFF.

Bit 10 User Input 2 – User Input 2 setting is configurable (factory default is Close Inhibit). Referenced as Terminal 35. Connect with 120 VAC or 24 VDC. Minimum ON voltage 19.2 VAC/DC; maximum OFF voltage 5.0 VAC/DC. Value of 1=True/ON, Value of 0=False/OFF.

Bit 11 Remote Stop Input – Referenced as Terminal 26. Connect with 120 VAC or 24 VDC. Minimum ON voltage 19.2 VAC/DC; maximum OFF voltage 5.0 VAC/DC. Value of 1=False/OFF, Value of 0=True/ON.

Bit 12 Remote Open Input – Referenced as Terminal 25. Connect with 120 VAC or 24 VDC. Minimum ON voltage 19.2 VAC/DC; maximum OFF voltage 5.0 VAC/DC. Value of 1=True/ON, Value of 0=False/OFF.

Bit 13 Remote Close Input – Referenced as Terminal 27. Connect with 120 VAC or 24 VDC. Minimum ON voltage 19.2 VAC/DC; maximum OFF voltage 5.0 VAC/DC. Value of 1=True/ON, Value of 0=False/OFF.

Bits 14 User Input 6 – User Input 6 setting is configurable. Connect with 120 VAC or 24 VDC. Minimum ON voltage 19.2 VAC/DC; maximum OFF voltage 5.0 VAC/DC. Value of 1=True/ON, Value of 0=False/OFF.

Bits 15 Bit 15 User Input 7 – User Input 7 setting is configurable. Connect with 120 VAC or 24 VDC. Minimum ON voltage 19.2 VAC/DC; maximum OFF voltage 5.0 VAC/DC. Value of 1=True/ON, Value of 0=False/OFF.

Register 13

Digital Inputs 2 register. Read-only. 16-bit unsigned value. Contains field unit status and digital input status.

Bit 00 Analog Board 1 Present - Indicates optional analog board #1 is present . Value of 1=True, Value of 0=False.

Bit 01 Analog Board 2 Present - Indicates optional analog board #2 is present. Value of 1=True, Value of 0=False.

Bit 02 Analog Input 0 Lost - Indicates optional analog input 0 is not receiving a 4-20 mA signal. Referenced as Terminals 20 and 19 (common). Value of 1=True, Value of 0=False.

Bit 03 Analog Input 1 Lost - Indicates optional analog input 1 is not receiving a 4-20 mA signal. Referenced as Terminals 12 and 17 (common). Value of 1=True, Value of 0=False.

Bit 04 Network Channel A & B Lost - Indicates field unit has stopped communicating on network Channel A (Register 9 bit 10) AND has stopped communicating on network Channel B (Register 9 Bit 11). The bit is ONLY available via the local serial port. Value of 1=True, Value of 0=False.

Bit 05 Relay Board R5-R8 Present - Indicates optional relay board is present. Value of 1=True, Value of 0=False.

Bit 06 DDC Board Present - Indicates presence of optional DDC-100 board. This board allows the actuator to be configured for use on the DDC-100 network. Value of 1=True, Value of 0=False.

Bit 07 I/O Relay Board R1-R4 & RM Present - Indicates presence of optional relay board. This board provides R1-R4 Relays and RM monitor relay. Value of 1=True, Value of 0=False.

Bit 08 Foundation Fieldbus Board Present - Indicates presence of optional Foundation Fieldbus board. This board allows the actuator to be configured for use on a Foundation Fieldbus network. Value of 1=True, Value of 0=False.

Bit 09 Profibus PA Board Present - Indicates presence of optional Profibus PA board. This board allows the actuator to be configured for use on a Profibus PA network. Value of 1=True, Value of 0=False.

Bit 10 User Input 2 Configured For CSE - Indicates that user input 2 is configured for CSE Remote Selected indication. This allows the remote control station to operate the actuator. Value of 1=True, Value of 0=False.

Bit 11 DeviceNet Board Present - Indicates presence of optional DeviceNet board. This board allows the actuator to be configured for use on a DeviceNet network. Value of 1=True, Value of 0=False.

Bit 12 Phase Lost - Indicates field unit has noticed a phase(s) is absent for the three-phase power. Value of 1=True, Value of 0=False.

Bit 13 Phase Reverse - Indicates field unit has noticed a three-phase rotation is incorrect. The field unit will operate the actuator in the proper direction to prevent damage to the valve. Value of 1=True, Value of 0=False.

Bit 14 User Input 8 - User Input 8 setting is configurable. Connect with 120 VAC or 24 VDC. Minimum ON voltage 19.2 VAC/DC; maximum OFF voltage 5.0 VAC/DC. Value of 1=True/ON, Value of 0=False/OFF.

Bit 15 Profibus DP Board Present - Indicates presence of optional Profibus DP board. This board allows the actuator to be configured for use on a Profibus DP network. Value of 1=True, Value of 0=False.

Register 14

Internal Temperature register. Read-only. 16-bit unsigned value. Contains field unit compartment temperature. Range is +90°C to -55°C. High byte 00 indicates positive (+) and 01 indicates negative (-). Low byte indicates temperature value.

Example: 0x0019 = +25°C
0x011E = -30°C

Register 15

Torque register. Read-only. 16-bit unsigned value. Default scale is 0-100 increments of open. May be adjusted to different scaling of 0-255 or 0-4095.

Scaling chosen through **Analog Scale** parameter within the DDC configuration (see **Section 3.3.1.2 Changing DDC Parameters**).

C

Appendix – Device Identification Data

MX Actuator ID Information

Response Frame		
Field Name	Size (Bytes)	Value (Hex)
Function Code	1	0x11
Byte Count	1	0x3B
Server ID	1	0x00
Run Indication	1	0x00
QA Stamp	8	ASCII String Format = 'XXXXXXXX'
QA Date	8	ASCII String Format = 'XXXXXXXX'
QA Time	6	ASCII String Format = 'XXXXXX'
MOV Type	1	0x00 = MX THT/UEC-3 0x10 = MX SMT 0x60 = QX 0x90 = MXa 0xA0 = UEX 0xB0 = QXM
Tag Name	16	ASCII String Format = 'XXXXXXXXXXXXXXXXXX'
Main Board Application	8	ASCII String Format = 'XXMXX.XX'
Main Board Bootloader	2	USIGN16 Format = '0XXXX'
Main Board CPLD	2	USIGN16 Format = '0XXXX'
Modbus DDC Version	1	USIGN8 Format = '0xXX'
Unit Size, Voltage, Frequency, and Starter Configuration	2	Unit Voltage (Lowest Nibble)
		0XXX0 = 110V 0XXX1 = 208V
		0XXX2 = 230V 0XXX3 = 380V
		0XXX4 = 400V 0XXX5 = 415V
		0XXX6 = 460V 0XXX7 = 525V
		0XXX8 = 575V 0XXX9 = 515V
		Unit Size (2nd Lowest Nibble)
		0XX0X = MX(a)-05 0XX1X = MX(a)-10
		0XX2X = MX(a)-20 0XX3X = MX(a)-40
		0XX4X = MX(a)-85 0XX5X = MX(a)-140
		0XX6X = MX(a)-150
		Unit Frequency (2nd Highest Nibble)
		0X0XX = 60Hz 0X1XX = 50Hz
		Unit Starter (Highest Nibble)
		0XXXX = EM 08XXX = SSMR
		Unit RPM

MX Actuator ID Information (cont.)

Response Frame		
Field Name	Size (Bytes)	Value (Hex)
Capabilities	2	Option Boards (LH = Present)
		0XXX4 = Analog 1 (AO)
		0XXX8 = Analog 2 (AO)
		0XX4X = R5-R8 Relays
		0XX8X = R1-R4 Relays
		0X1XX = Modbus DDC
		08XXX = Custom Discrete Inputs
		Other Options (LH = Available)
		0XX1X = 2-Speed Timers
		0XX2X = Modutronic (mA In)

QX & QXM Actuator ID Information

Response Frame		
Field Name	Size (Bytes)	Value (Hex)
Function Code	1	0x11
Byte Count	1	0x4C
Server ID	1	0x00
Run Indication	1	0x00
QA Stamp	8	ASCII String
		Format = 'XXXXXXXX'
QA Date	8	ASCII String
		Format = 'XXXXXXXX'
QA Time	6	ASCII String
		Format = 'XXXXXX'
MOV Type	1	0x00 = MX THT/UEC-3
		0x10 = MX SMT
		0x60 = QX
		0x90 = MXa
		0xA0 = UEX
		0xB0 = QXM
Tag Name	16	ASCII String
		Format = 'XXXXXXXXXXXXXXXXXX'
Main Board Application	8	ASCII String
		Format = 'XXXXXXXX'
Main Board Bootloader	2	USIGN16
		Format = '0XXXX'
Main Board CPLD	2	USIGN16
		Format = '0XXXX'
Modbus DDC Version	1	USIGN8
		Format = '0xXX'
Motor Controller Application	8	ASCII String
		Format = 'XXXXXXXX'
Motor Controller Bootloader	8	ASCII String
		Format = 'XXXXXXXX'

QX & QXM Actuator ID Information (cont.)

Response Frame		
Field Name	Size (Bytes)	Value (Hex)
Encoder Firmware	1	USIGN8 Format = '0xXX'
Unit Size, Voltage, and Frequency	2	Unit Voltage (Lowest Nibble)
		0xXXX0 = 110V 0xXXX1 = 208V
		0xXXX2 = 230V 0xXXX3 = 380V
		0xXXX4 = 400V 0xXXX5 = 415V
		0xXXX6 = 460V 0xXXX7 = 525V
		0xXXX8 = 575V 0xXXX9 = 515V
		0XXXXA = 24VDC
		Unit Size (Highest Byte)
		0x0XXX = QX-1 0x1XXX = QX-2
		0x2XXX = QX-3 0x3XXX = QX-4
		0x4XXX = QX-5
		0x5XXX = QXM-1 (6 ½ Turns)
		0x6XXX = QXM-2 (6 ½ Turns)
		0x7XXX = QXM-3 (6 ½ Turns)
		0x8XXX = QXM-4 (6 ½ Turns)
		0x9XXX = QXM-5 (6 ½ Turns)
		0xA0XX = QXM-1 (20 Turns)
		0xB0XX = QXM-1 (20 Turns)
		0xC0XX = QXM-1 (20 Turns)
		0xD0XX = QXM-1 (20 Turns)
		0xE0XX = QXM-1 (20 Turns)
0xF0XX = QXM-1H (6 ½ Turns)		
0x10XX = QXM-1L (6 ½ Turns)		
0x11XX = QXM-1H (20 Turns)		
0x12XX = QXM-1L (20 Turns)		
Unit Frequency (Highest Bit)		
0x0XXX = 60Hz 0x1XXX = 50Hz		
Unit RPM	1	USIGN8 Format = '0xXX'
Capabilities	2	Option Boards (LH = Present)
		0XXXX4 = Analog 1 (AO)
		0XXXX8 = Analog 2 (AO)
		0XX4X = R5-R8 Relays
		0XX8X = R1-R4 Relays
		0X1XX = Modbus DDC
		08XXX = Custom Discrete Inputs
		Other Options (LH = Available)
		0XX1X = 2-Speed Timers
0XX2X = Modutronic (mA In)		

D Appendix – Typical DDC-100 Network Installation Assignments

Various project suppliers play important roles in the design, purchase, installation, and commissioning of a plant control system. A typical assignment of roles for the installation of a DDC-100 Network with its valve controllers is presented in this section. This material is presented for guidance only and is not necessarily representative of a particular installation.

Project supplier responsibilities

S.I. (System Integrator) Responsible for developing code to operate the plant per the specification. This includes the interface between the DDC-100 Network and the Host. The System Integrator may be a third-party programmer or a site engineer responsible for computer programming.

Engineer (Project Engineer) Responsible for developing the site layout, specifications, and requirements for the project.

Contractor Responsible for site project development. The contractor is the site coordinator responsible for completing the upgrade or new facility installation per the specification. This may be a third-party (independent) contractor or a site maintenance group.

Flowserve Limitorque Valve actuator manufacturer. Supplier of the valve actuators per the specification.

OEM (Valve Original Equipment Manufacturer) Valve manufacturer responsible for providing valves per specification to contractor or job site. The valve OEM may also provide the Limitorque actuators as a part of its scope of supply.

Fourth-Party Hardware/Software Supplier of hardware and/or software packages needed to complete system integrator's scope of supply. Equipment typically includes: PLC racks, components, personal computers, Graphical User Interfaces, etc.

System Integrator Tasks

Specification	Engineer	S.I	Detail functionality of system
Schedule	Contractor	S.I.	Production Schedule
Manuals	Limatorque	S.I.	Manuals for DDC-100 Operation: <ul style="list-style-type: none"> • LMAIM4019 Direct-to-Host Programming Guide • LMENIM2329 DDC-100 Field Unit IOM Manual
Hardware for system development	Contractor	S.I.	DDC-100 Field Units, signal converters
Fourth-Party Hardware/Software	Component supplier	S.I.	Modbus interface modules, Modbus drivers, non-Limatorque converters, or surge suppression
Actuator	Contractor	S.I.	Availability of DDC-100 Field Unit for testing developed application software
Site Preparation	Contractor	S.I.	Complete actuator or field unit installation. Provide actual (as installed) site loop diagram to System Integrator
Operational System	S.I.	Contractor	Software only (code) or Hardware and Software (hardware and code)
Documentation	S.I.	Contractor	System Operation and Maintenance Manuals, Operational characteristics of system, Network Addresses to equipment tag names

Engineer Tasks

Deliverable	From	To	Comments
Specification	End-user	Engineer	Site and system requirements
Schedule	End-user	Engineer	Production Schedule. Completion dates
Sales Support	Limatorque	Engineer	Information on Limatorque products
Manuals	Limatorque	Engineer	Manuals for DDC-100 Operation: <ul style="list-style-type: none"> • LMAIM4019 Direct-to-Host Programming Guide • LMENIM2329 DDC-100 Field Unit IOM Manual
Project Specification	Engineer	Contractor, S/I, OEM, Limatorque	Provide operational specifications for all equipment and service providers
Project Responsibility	Engineer	Contractor	Define which supplier is responsible for each portion of project
P&ID	Engineer	Contractor	Detailed layout and instructions for building site. Information should include actuator tag names, required data points from actuator, field unit, and field wiring
Site Electrical and electronics	Engineer	Contractor	Detail site electrical requirements, cable type, layout, and locations. Voltages available for equipment
Loop Drawings	Engineer	Contractor	Detail cable routings from Host to each field device. This defines how the network cable is to run throughout the facility

Contractor Tasks

Deliverable	From	To	Comments
Specifications	Engineer	Contractor	Complete P&IDs for site
Schedule	Engineer	Contractor	Time line complete w/milestones
Project Responsibilities	Engineer	Contractor	Define which supplier is responsible for each portion of project
P&ID	Engineer	Contractor	Detailed layout and instructions for building site. Information should include actuator tag names, required data points from actuator, field unit, and field wiring
Site Electrical and electronics	Engineer	Contractor	Detail site electrical requirements, cable type, layout, and locations. Voltages available for equipment
Loop Drawings	Engineer	Contractor	Detail cable routings from Host to each field device. This defines how the network cable is to run throughout the facility
Schedule	Contractor	Limitorque	Provide material delivery dates for hardware. Schedule Flowserve Limitorque Controls Service Technician for actuator commissioning (when requested according to purchase order)
Hardware	Limitorque, OEM	Contractor	Provide Motor-Operated Valves, signal converters (if supplied), valves, mounting adapters, etc.
Manuals	Limitorque	Contractor	Product Bulletins for Actuators: LMAIM4019 Direct-to-Host Programming Guide LMENIM2329 DDC-100 Field Unit IOM Manual
Operational System	S.I.	Contractor	Develop and test programming for DCS system
Documents	S.I.	Contractor	Documentation of program operational characteristics, equipment used, and Operation and Maintenance Manuals for equipment
Schedule	Contractor	S.I.	Provide delivery dates for commissioning control system. Include dates for testing, documentation, and turnover to site personnel
Hardware for system development	Contractor	S.I.	Hardware may include: DDC-100 Field Units, signal converters
Actuator	Contractor	S.I.	Availability of DDC-100 Field Unit for testing developed application software
Site Preparation	Contractor	S.I.	Complete actuator or field unit installation. Provide actual (as installed)
Site Preparation	Contractor	Limitorque	Install specified equipment, cables for power and network communication. Verify all network and power cables are properly routed, terminated, and documented prior to commissioning of DDC-100 Network. The contractor should provide detail on network routing from Host system to each field unit. Verify all field units are properly grounded
Field Unit Startup	Limitorque	Contractor	According to purchase order requirements, when scheduled

Limitorque Tasks

Deliverable	From	To	Comments
Specifications	Engineer	Limitorque	Provide specification on Motor-Operated Valves, other DDC-100 Field Units (I/O Modules). Provide P&IDs
Schedule	Contractor	Limitorque	Provide material delivery dates for hardware. Schedule Flowserve Limitorque Controls Service Technician for actuator commissioning
Site Preparation	Contractor	Limitorque	Install specified equipment, cables for power, and network communication. Verify all network and power cables are properly routed, terminated, and documented prior to commissioning of DDC-100 Network. The contractor should provide detail on network routing from Host system to each field unit. Verify all field units are properly grounded
Operational	S.I.	Limitorque	Provide unique field unit requirements to Controls Service Technician Requirements prior to start of field unit commissioning process. Include: ESD requirements, open/close service or position control (“move-to”), digital inputs/ outputs, analog inputs
Tag List	S.I.	Limitorque	Provide a tag list detailing valve tag name to network address. This will allow the Limitorque Controls Service Technician (when requested according to purchase order) to properly address the actuators to the developed Host software
Sales Support	Limitorque	Engineer	Information on Limitorque products
Manuals	Limitorque	S.I. Engineer Contractor	Product Bulletins for Actuators: LMAIM4019 Direct-to-Host Programming Guide LMENIM2329 DDC-100 Field Unit IOM Manual
Hardware	Limitorque	Contractor	Provide Motor-Operated Valves, signal converters (if supplied), OEM valves, mounting adapters, etc.
Field Unit Startup	Limitorque	Contractor	According to purchase order requirements, when scheduled



Flowserve Corporation
Flow Control

United States

Flowserve Limitorque
5114 Woodall Road
P.O. Box 11318
Lynchburg, VA 24506-1318
Phone: 434-528-4400
Facsimile: 434-845-9736

Italy

Flowserve Limitorque
Via Rio Vallone 17
20883 Mezzago (MB), Italy
Phone: +39-039-62060-1
Facsimile: +39-039-62060-213

Japan

Limitorque – Nippon Gear Co., Ltd.
NOF Bldg. 9th Floor
1-11-11, Kita-Saiwai, Nishi-Ku
Yokohama (220-0004)
Japan
Phone: 81-45-326-2065
Facsimile: 81-45-320-5962

Singapore

Flowserve Limitorque
12, Tuas Avenue 20
Singapore 638824
Phone: 65-6868-4628
Facsimile: 65-6862-4940

China

Limitorque Beijing, Pte., Ltd.
RM A1/A2
22/F, East Area, Hanwei Plaza
No. 7 Guanghua Road, Chaoyang District
Beijing 100004, Peoples Republic of China
Phone: 86-10-5921-0606
Facsimile: 86-10-6561-2702

India

Flowserve Limitorque
Office A, 7th Floor, Plot No. 32 A&B
Ambit IT Park, Ambit IT Park Road
Ambattur Industrial Estate,
Chennai - 600058
Phone: 91-44-2432-8755
91-44-2432-4801
Facsimile: 91-44-2432-8754

To find your local Flowserve representative,
visit www.flowserve.com/limitorque
or call USA 1 800 225 6989

FCD LMENIM2329-02 AQ - 05/17 Printed in USA.

Flowserve Corporation has established industry leadership in the design and manufacture of its products. When properly selected, this Flowserve product is designed to perform its intended function safely during its useful life. However, the purchaser or user of Flowserve products should be aware that Flowserve products might be used in numerous applications under a wide variety of industrial service conditions. Although Flowserve can (and often does) provide general guidelines, it cannot provide specific data and warnings for all possible applications. The purchaser/user must therefore assume the ultimate responsibility for the proper sizing and selection, installation, operation, and maintenance of Flowserve products. The purchaser/user should read and understand the Installation Operation Maintenance (IOM) instructions included with the product, and train its employees and contractors in the safe use of Flowserve products in connection with the specific application.

While the information and specifications contained in this literature are believed to be accurate, they are supplied for informative purposes only and should not be considered certified or as a guarantee of satisfactory results by reliance thereon. Nothing contained herein is to be construed as a warranty or guarantee, express or implied, regarding any matter with respect to this product. Because Flowserve is continually improving and upgrading its product design, the specifications, dimensions and information contained herein are subject to change without notice. Should any question arise concerning these provisions, the purchaser/user should contact Flowserve Corporation at any one of its worldwide operations or offices.

© 2011 Flowserve Corporation, Irving, Texas, USA. Flowserve is a registered trademark of Flowserve Corporation.