

Rosemount™ 848T FOUNDATION™ Fieldbus High Density Temperature Transmitter

Device Revision 8 - Requires New DD/CFF
Revision



Contents

About this guide.....	3
Mount the transmitter.....	5
Wire and apply power.....	9
Verify the tag.....	16
Verify the transmitter configuration.....	17
Product certifications.....	18
Declaration of conformity.....	33
China RoHS.....	35

1 About this guide

This guide provides basic guidelines for the Rosemount 848T Temperature Transmitter. It does not provide instructions for detailed configuration, diagnostics, maintenance, service, troubleshooting. Refer to the Rosemount 848T [Reference Manual](#) for more instruction. The manual and this guide are also available electronically on [Emerson.com/Rosemount](https://www.emerson.com/Rosemount)

⚠ WARNING

Explosions could result in death or serious injury.

Installation of this transmitter in an explosive environment must be in accordance with the appropriate local, national, and international standards, codes, and practices. Review the approvals section of this manual for any restrictions associated with a safe installation.

- Before connecting a Field Communicator in an explosive atmosphere, make sure the instruments in the loop are installed in accordance with intrinsically safe or non-incendive field wiring practices.

Electrical shock can result in death or serious injury.

- Avoid contact with the leads and terminals. High voltage that may be present on leads can cause electrical shock.

Physical access

- Unauthorized personnel may potentially cause significant damage to and/or misconfiguration of end users' equipment. This could be intentional or unintentional and needs to be protected against.
- Physical security is an important part of any security program and fundamental to protecting your system. Restrict physical access by unauthorized personnel to protect end users' assets. This is true for all systems used within the facility.

⚠ CAUTION

This device complies with Part 15 of the FCC Rules. Operation is subject to the following conditions:

- This device may not cause harmful interference.
- This device must accept any interference received, including interference that may cause undesired operation.
- This device must be installed to ensure a minimum antenna separation distance of 7.9 in. (20 cm) from all persons.

NOTICE

Battery hazards remain when cells are discharged.

The power module may be replaced in a hazardous area. The power module has surface resistivity greater than one gigaohm and must be properly installed in the wireless device enclosure. Care must be taken during transportation to and from the point of installation to prevent electrostatic charge build-up.

Shipping considerations for wireless products.

- The unit was shipped to you without the power module installed. Remove the power module prior to shipping.
 - Each power module contains two “C” size primary lithium batteries. Primary lithium batteries are regulated in transportation by the U. S. Department of Transportation, and are also covered by IATA (International Air Transport Association), ICAO (International Civil Aviation Organization), and ARD (European Ground Transportation of Dangerous Goods). It is the responsibility of the shipper to ensure compliance with these or any other local requirements. Consult current regulations and requirements before shipping.
-

2 Mount the transmitter

2.1 Mount to a DIN rail without a junction box

Procedure

1. Pull up the DIN rail mounting clip located on the top back side of the transmitter.
2. Hinge the DIN rail into the slots on the bottom of the transmitter.
3. Tilt the Rosemount 848T and place onto the DIN rail.
4. Release the mounting clip.

Figure 2-1: Mounting the Rosemount 848T to a DIN Rail

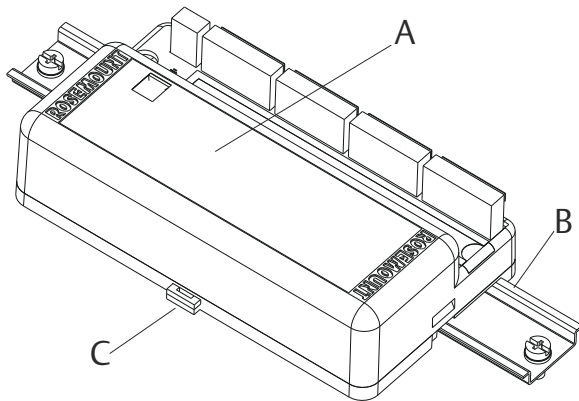

- A. Rosemount 848T without installed enclosure
B. DIN rail
C. DIN rail mounting clip
-

2.2 Mount to a panel with a junction box

Figure 2-2: Aluminum/Plastic Junction Box

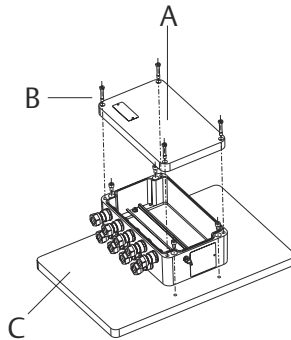

- A. Aluminum or plastic junction box
 - B. Mounting screws (4)⁽¹⁾
 - C. Panel
-

Figure 2-3: Stainless Steel Junction Box

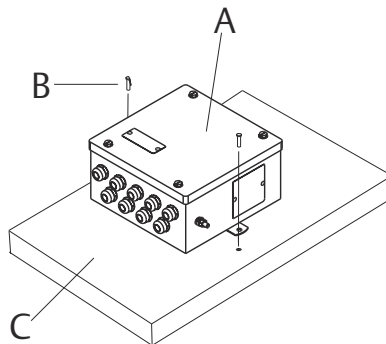

- A. Stainless steel junction box
 - B. Mounting screws (2)⁽¹⁾
 - C. Panel
-

⁽¹⁾ Mount using four $\frac{1}{4}$ -20 x 1.25-in. screws.

2.3 Mount to a 2-in. pipe stand

Prerequisites

Use the optional mounting bracket (option code B6) to attach the Rosemount 848T to a 2-in. pipe stand when using a junction box.

Figure 2-4: Aluminum/Plastic Junction Box

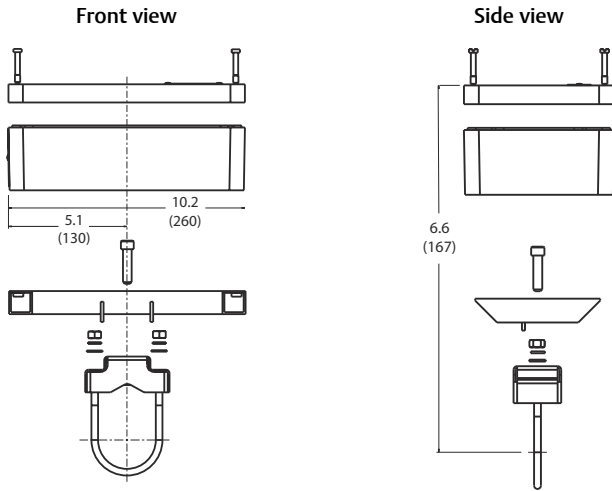

Figure 2-5: Stainless Steel Junction Box

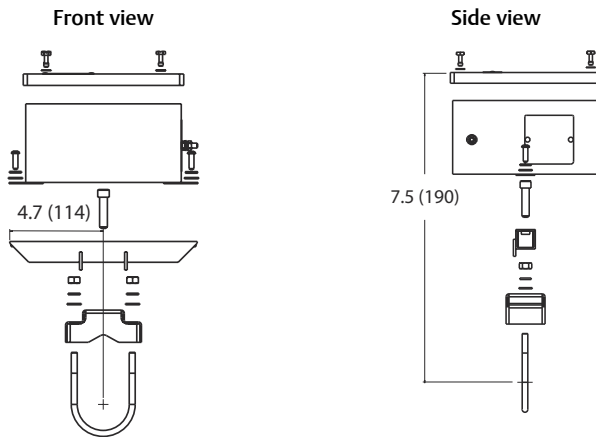
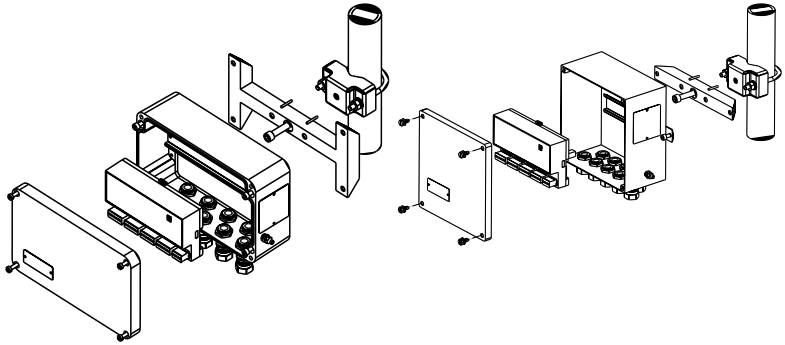

Figure 2-6: Mounted on a Vertical Pipe

Aluminum/plastic junction box

Stainless steel junction box



3 Wire and apply power

3.1 Using cable glands

Figure 3-1: Cable Gland

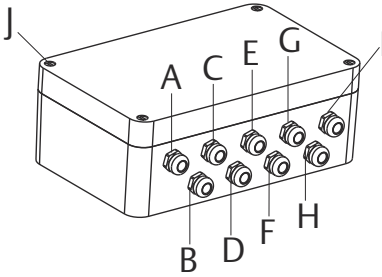

- A. Sensor 1
 - B. Sensor 2
 - C. Sensor 3
 - D. Sensor 4
 - E. Sensor 5
 - F. Sensor 6
 - G. Sensor 7
 - H. Sensor 8
 - I. Power/signal
 - J. Cover screw
-

Procedure

1. Remove the four cover screws to remove the junction box cover.
2. Run the sensor and power/signal wires through the appropriate pre-installed cable glands.
3. Install the sensor wires into the correct screw terminals.
4. Attach the FOUNDATION Fieldbus wires to the screw terminals.
5. Replace the FOUNDATION Fieldbus cover and tighten all cover screws.

3.2 Using conduit entries

Figure 3-2: Conduit Entries

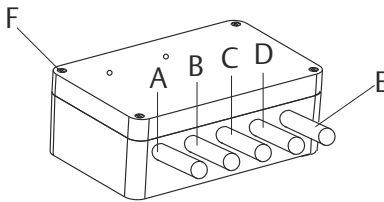

- A. Sensor 1 and 2
- B. Sensor 3 and 4
- C. Sensor 5 and 6
- D. Sensor 7 and 8
- E. Power/signal
- F. Cover screw

Procedure

1. Unscrew the four cover screws to remove the junction box cover.
2. Remove the five conduit plugs and install the user-supplied conduit fittings.
3. Run pairs of sensor wires through each conduit fitting.
4. Install the sensor wires into the correct screw terminals.
5. Attach the FOUNDATION Fieldbus wires to the screw terminals.
6. Replace the enclosure cover and tighten all cover screws.

3.3 Sensor wiring and power supply

- Compatible with eight independently configurable channels including combinations of 2- and 3-wire RTDs, thermocouples, mV, ohm, and mA sensors.
- All sensor and power terminals are rated to 42.4 Vdc.
- FOUNDATION Fieldbus network powered with a terminal voltage of 9.0–32.0 Vdc and 22 mA maximum current draw.
- For best network performance twisted, shielded pair cabling should be used. Proper gage wire should be selected to maintain the 9.0 Vdc minimum.

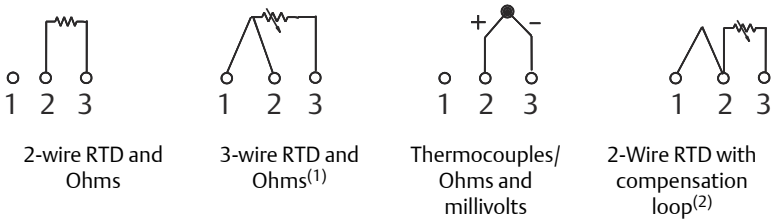
Figure 3-3: Sensor Wiring Diagrams

- (1) Emerson provides 4-wire sensors for all single-element RTDs. Use these RTDs in 3-wire configurations by clipping the fourth lead or leaving it disconnected and insulated with electrical tape.
 - (2) The transmitter must be configured for a 3-wire RTD in order to recognize an RTD with a compensation loop.
-

The wiring of 3-wire RTDs for this unit is different than some earlier Rosemount 848T models. Pay careful attention to the wiring diagram on the label, especially if this unit is replacing an older unit.

3.4 Wiring analog inputs

Figure 3-4: Rosemount 848T Analog Input Wiring Diagram

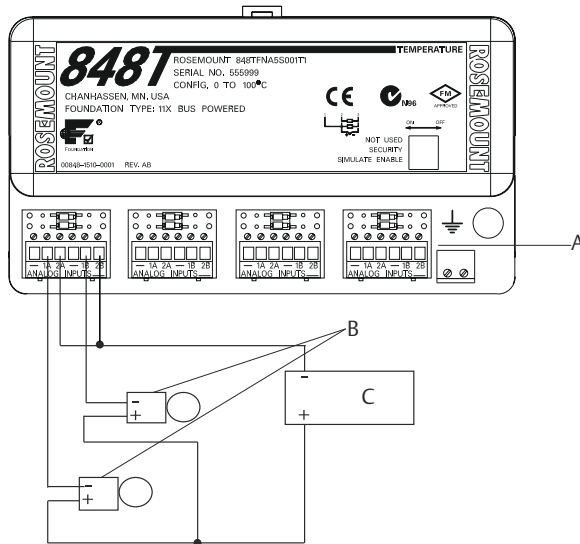

- A. Analog input connectors
- B. Analog transmitters
- C. Power supply

3.5 Typical configuration for FOUNDATION Fieldbus networking

Note

Each segment in a FOUNDATION Fieldbus trunk must be terminated at both ends.

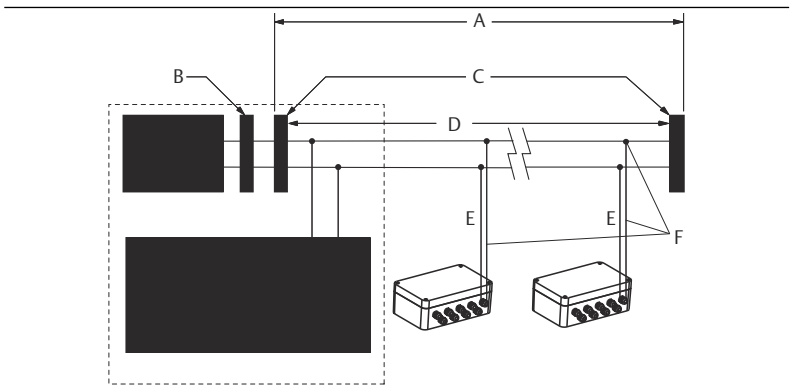

- A. 6234 ft. (1900 m) max (depending upon cable characteristics)
- B. Integrated power conditioner and filter
- C. Terminators
- D. Trunk
- E. Sput
- F. Signal wiring

3.5.1 Ground the transmitter

Proper ground is crucial to reliable temperature readings.

3.5.2 Ungrounded thermocouple, mV, and RTD/Ohm inputs Option 1

Procedure

1. Connect FOUNDATION Fieldbus signal wiring shield to the sensor wiring shield(s).
2. Ensure the shields are tied together and electrically isolated from the transmitter enclosure.
3. Only ground the shield at the power supply end.
4. Ensure that the sensor shield(s) is electrically isolated from the surrounding grounded fixtures.

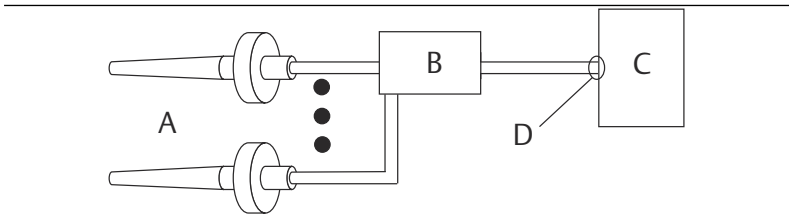

- A. Sensor wires
- B. Rosemount 848T
- C. Power supply
- D. Shield ground point

Option 2

Procedure

1. Connect sensor wiring shield(s) to the transmitter enclosure (only if the enclosure is grounded).
2. Ensure the sensor shield(s) is electrically isolated from surrounding fixtures that may be grounded.
3. Ground FOUNDATION Fieldbus signal wiring shield at the power supply end.

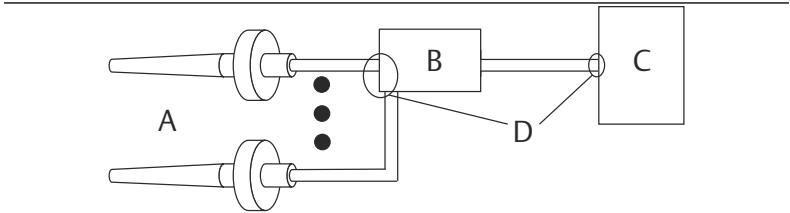

- A. Sensor wires
- B. Rosemount™ 848T
- C. Power supply
- D. Shield ground point

3.5.3 Grounded thermocouple inputs

Procedure

1. Ground sensor wiring shield(s) at the sensor.
2. Ensure the sensor wiring and FOUNDATION Fieldbus signal wiring shields are electrically isolated from the transmitter enclosure.
3. Do not connect the FOUNDATION Fieldbus signal wiring shield to the sensor wiring shield(s).

4. Ground FOUNDATION Fieldbus signal wiring shield at the power supply end.

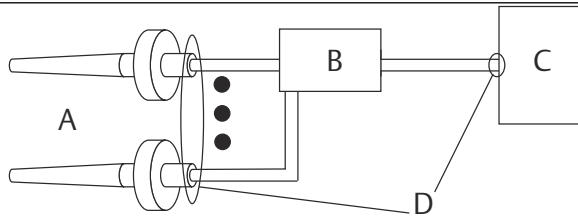

- A. Sensor wires
- B. Rosemount 848T
- C. Power supply
- D. Shield ground point

3.6 Analog device inputs

Procedure

1. Ground analog signal wire at the power supply of the analog devices.
2. Ensure the analog signal wire and the FOUNDATION Fieldbus signal wire shields are electrically isolated from the transmitter enclosure.
3. Do not connect the analog signal wire shield to the FOUNDATION Fieldbus signal wire shield.

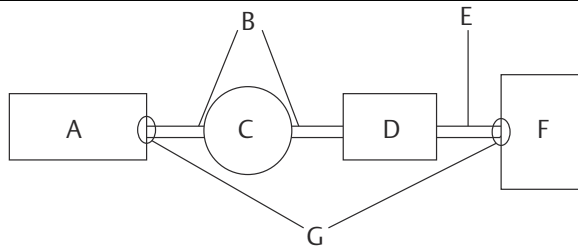

- A. Analog device power supply
- B. 4–20 mA loop
- C. Analog device
- D. Rosemount 848T
- E. FOUNDATION Fieldbus
- F. Power supply
- G. Shield ground points

3.6.1 Transmitter enclosure (optional)

Ground in accordance with local electrical requirements.

4 Verify the tag

The Rosemount 848T has a removable commissioning tag that contains both the Device ID (the unique code that identifies a particular device in the absence of a device tag) and a space to record the device tag (the operational identification for the device as defined by the Piping and Instrumentation Diagram [P&ID]).

When commissioning more than one device on a FOUNDATION Fieldbus segment, it can be difficult to identify which device is at a particular location. The removable tag aids in this process by linking the Device ID to physical location. The installer should note the physical location of the transmitter on both the upper and lower location of the commissioning tag. The bottom portion should be torn off for each device on the segment and used for commissioning the segment in the control system.



5 Verify the transmitter configuration

Each FOUNDATION Fieldbus host or configuration tool has a different way of displaying and performing configurations. Some use Device Descriptions (DD) or DD wizards for configuration and to display data consistently across platforms. There is no requirement that a host or configuration tool support these features.

The following is the minimum configuration requirement for a temperature measurement. This guide is designed for systems not using DD wizards. For a complete list of parameters and configuration information refer to the Rosemount 848T [Reference Manual](#).

6 Product certifications

Rev 3.8

European Directive Information

A copy of the EU Declaration of Conformity can be found at the end of the Quick Start Guide. The most recent revision of the EU Declaration of Conformity can be found at Emerson.com/Rosemount.

Ordinary Location Certification from FM Approvals

As standard, the transmitter has been examined and tested to determine that the design meets the basic electrical, mechanical, and fire protection requirements by FM Approvals, a nationally recognized test laboratory (NRTL) as accredited by the Federal Occupational Safety and Health Administration (OSHA).

North America

The US National Electrical Code™ (NEC) and the Canadian Electrical Code (CEC) permit the use of Division marked equipment in Zones and Zone marked equipment in Divisions. The markings must be suitable for the area classification, gas, and temperature class. This information is clearly defined in the respective codes.

6.1 U.S.A

6.1.1 I5 FM Intrinsically Safe and Nonincendive

Certificate 3011568

Standards FM Class 3600:1998, FM Class 3610:2010, FM Class 3611:2004, FM Class 3810:2005, ANSI/ISA 60079-0:2009, ANSI/ISA 60079-11:2009, NEMA 250:1991, IEC 60529:2011

Markings IS CL I, DIV 1, GP A, B, C, D; T4($-50\text{ °C} \leq T_a \leq +60\text{ °C}$); NI CL I, DIV 2, GP A, B, C, D; T4A($-50\text{ °C} \leq T_a \leq +85\text{ °C}$); T5($-50\text{ °C} \leq T_a \leq +70\text{ °C}$) when installed per Rosemount drawing 00848-4404.

Note

Transmitters marked with Nonincendive CL I, DV 2 can be installed in Division 2 locations using general Division 2 wiring methods or Nonincendive Field Wiring (NIFW). See Drawing 00848-4404.

6.1.2 IE FM FISCO

Certificate 3011568

Standards FM Class 3600:1998, FM Class 3610:2010, FM Class 3611:2004, FM Class 3810:2005, ANSI/ISA 60079-0:2009, ANSI/ISA 60079-11:2009, NEMA 250:1991, IEC 60529:2011

Markings IS CL I, DIV 1, GP A, B, C, D; T4($-50\text{ }^{\circ}\text{C} \leq T_a \leq +60\text{ }^{\circ}\text{C}$); NI CL I, DIV 2, GP A, B, C, D; T4A($-50\text{ }^{\circ}\text{C} \leq T_a \leq +85\text{ }^{\circ}\text{C}$); T5($-50\text{ }^{\circ}\text{C} \leq T_a \leq +70\text{ }^{\circ}\text{C}$) when installed per Rosemount drawing 00848-4404.

6.1.3 N5 Nonincendive and Dust-Ignitionproof

Certificate 3011568

Standards FM Class 3600:1998, FM Class 3611:2004, FM Class 3810:2005, ANSI/ISA 60079-0:2009, NEMA 250:1991, IEC 60529:2011

Markings NI CL I, DIV 2, GP A, B, C, D; DIP CL II/III, DIV 1, GP E, F, G; T4A($-50\text{ }^{\circ}\text{C} \leq T_a \leq +85\text{ }^{\circ}\text{C}$); T5($-50\text{ }^{\circ}\text{C} \leq T_a \leq +70\text{ }^{\circ}\text{C}$) when installed per Rosemount drawing 00848-4404; Type 4X

6.1.4 NK Nonincendive

Certificate 3011568

Standards FM Class 3600:1998, FM Class 3611:2004, FM Class 3810:2005, ANSI/ISA 60079-0:2009, NEMA 250:1991, IEC 60529:2001

Markings NI CL I, DIV 2, GP A, B, C, D; T4A($-50\text{ }^{\circ}\text{C} \leq T_a \leq +85\text{ }^{\circ}\text{C}$); T5($-50\text{ }^{\circ}\text{C} \leq T_a \leq +70\text{ }^{\circ}\text{C}$) when installed per Rosemount drawing 00848-4404

Note

Only the N5 and NK are valid with the S002 option.

Table 6-1: MAI Block Parameters

Fieldbus (input)	FISCO (input)	Nonincendive (input)	Sensor field terminal (output)
$V_{MAX} = 30\text{ V}$	$V_{MAX} = 17.5$	$V_{MAX} = 42.4$	$V_{OC} = 12.5\text{ V}$
$I_{MAX} = 300\text{ mA}$	$I_{MAX} = 380\text{ mA}$	$C_i = 2.1\text{ nF}$	$I_{SC} = 4.8\text{ mA}$
$P_i = 1.3\text{ W}$	$P_i = 5.32\text{ W}$	$L_i = 0$	$P_O = 15\text{ mW}$
$C_i = 2.1\text{ nF}$	$C_i = 2.1\text{ nF}$	N/A	$C_A = 1.2\text{ }\mu\text{F}$
$L_i = 0$	$L_i = 0$	N/A	$L_A = 1\text{ H}$

6.2 Canada

6.2.1 E6 CSA Explosionproof, Dust-Ignitionproof, Division 2 (JX3 Enclosure Required)

Certificate 1261865

Standards CAN/CSA C22.2 No. 0-M91 (R2001), CSA Std. C22.2 No. 25.1966, CSA Std. C22.2 No. 30-M1986, CAN/CSA C22.2 No. 94-M91, CSA Std. C22.2 No. 142-M1987, CSA Std. C22.2 No. 213-M1987, CSA Std. C22.2 No. 60529:05

Markings Explosionproof for Class I, Division 1, Groups B, C, and D; T4(-40 °C ≤ T_a ≤ +40 °C) when installed per Rosemount drawing 00848-1041; Dust-Ignitionproof for Class II, Division 1, Groups E, F, and G; Class III; Class I, Division 2, Groups A, B, C, and D; T3C(-50 °C ≤ T_a ≤ +60 °C) when installed per Rosemount drawing 00848-4405; Conduit Seal Required

6.2.2 I6 CSA Intrinsically Safe and Division 2

Certificate 1261865

Standards CAN/CSA C22.2 No. 0-M91 (R2001), CAN/CSA C22.2 No. 94-M91, CSA Std. C22.2 No. 142-M1987, CSA Std. C22.2 No. 157-92, CSA Std. C22.2 No. 213-M1987, CSA Std. C22.2 No. 60529:05

Markings Intrinsically Safe for Class I, Division 1, Groups A, B, C, and D; T3C(-50 °C ≤ T_a ≤ +60 °C) when installed per Rosemount drawing 00848-4405; Class I, Division 2, Groups A, B, C, D; T3C(-50 °C ≤ T_a ≤ +60 °C) when installed per Rosemount drawing 00848-4405

6.2.3 IF CSA FISCO

Certificate 1261865

Standards CAN/CSA C22.2 No. 0-M91 (R2001), CAN/CSA C22.2 No. 94-M91, CSA Std. C22.2 No. 142-M1987, CSA Std. C22.2 No. 157-92, CSA Std. C22.2 No. 213-M1987, CSA Std. C22.2 No. 60529:05

Markings Intrinsically Safe for Class I, Division 1, Groups A, B, C, and D; T3C(-50 °C ≤ T_a ≤ +60 °C) when installed per Rosemount drawing 00848-4405; Class I, Division 2, Groups A, B, C, D; T3C(-50 °C ≤ T_a ≤ +60 °C) when installed per Rosemount drawing 00848-4405

6.2.4 N6 CSA Division 2 and Dust-Ignitionproof (enclosure required)

Certificate 1261865

Standards CAN/CSA C22.2 No. 0-M91 (R2001), CSA Std. C22.2 No. 30-M1986, CAN/CSA C22.2 No. 94-M91, CSA Std. C22.2 No. 142-M1987, CSA Std. C22.2 No. 213-M1987, CSA Std. C22.2 No. 60529:05

Markings Class I, Division 2, Groups A, B, C, and D; T3C($-50\text{ }^{\circ}\text{C} \leq T_a \leq +60\text{ }^{\circ}\text{C}$) when installed per Rosemount drawing 00848-4405; Dust-Ignitionproof for Class II, Division 1, Groups E, F, and G; Class III; Conduit Seal Required

6.3 Europe

6.3.1 I1 ATEX Intrinsic Safety

Certificate Baseefa09ATEX0093X

Standards EN IEC 60079-0:2018, EN 60079-11:2012

Markings  II 1 G Ex ia IIC T4 Ga ($-50\text{ }^{\circ}\text{C} \leq T_a \leq +60\text{ }^{\circ}\text{C}$) when installed per drawing 00848-4406

Special Conditions for Safe Use (X):

1. The equipment must be installed in an enclosure that provides a degree of protection of at least IP20. Non-metallic enclosures must be suitable to prevent electrostatic hazards and light alloy or zirconium enclosures must be protected from impact and friction when installed.
2. The equipment is not capable of withstanding the 500 V insulation test required by EN 60079-11:2011, clause 6.3.13. This must be taken into account when installing the equipment.

Fieldbus (input)	Sensor field terminal (output)
$U_i = 30\text{ V}$	$U_o = 12.5\text{ V}$
$I_i = 300\text{ mA}$	$I_o = 4.8\text{ mA}$
$P_i = 1.3\text{ W}$	$P_o = 15\text{ mW}$
$C_i = 2.1\text{ nF}$	$C_o = 1.2\text{ }\mu\text{F}$
$L_i = 0$	$L_o = 1\text{ H}$

6.3.2 IA ATEX FISCO Intrinsic Safety

Certificate Baseefa09ATEX0093X

Standards EN IEC 60079-0:2018, EN 60079-11:2012

Markings  II 1 G Ex ia IIC T4 Ga ($-50\text{ °C} \leq T_a \leq +60\text{ °C}$) when installed per drawing 00848-4406

Special Conditions for Safe Use (X):

1. The equipment must be installed in an enclosure that provides a degree of protection of at least IP20. Non-metallic enclosures must be suitable to prevent electrostatic hazards and light alloy or zirconium enclosures must be protected from impact and friction when installed.
2. The equipment is not capable of withstanding the 500 V insulation test required by EN 60079-11:2011, clause 6.3.13. This must be taken into account when installing the equipment.

FISCO (input)	Sensor field terminal (output)
$U_i = 17.5\text{ V}$	$U_o = 12.5\text{ V}$
$I_i = 380\text{ mA}$	$I_o = 4.8\text{ mA}$
$P_i = 5.32\text{ W}$	$P_o = 15\text{ mW}$
$C_i = 2.1\text{ nF}$	$C_o = 1.2\text{ }\mu\text{F}$
$L_i = 0$	$L_o = 1\text{ H}$

6.3.3 N1 ATEX Zone 2 (with enclosure)

Certificate Baseefa09ATEX0095X

Standards EN IEC 60079-0:2018, EN 60079-7:2015 + A1:2018, EN 60079-15:2010

Markings  II 3G Ex nA IIC T5 Gc ($-40\text{ °C} \leq T_a \leq +65\text{ °C}$), Ex ec IIC T5 Gc ($-40\text{ °C} \leq T_a \leq +65\text{ °C}$)

Special Conditions for Safe Use (X):

1. The equipment must only be installed in an area of pollution degree 2 or better, as defined in IEC 60664-1.
2. Provision must be made, external to the equipment, to ensure the rated voltage of the equipment supply is not exceeded by transient disturbances of more than 40 percent.

- The electrical circuit is connected directly to earth; this must be taken into account when installing the apparatus.

6.3.4 NC ATEX Zone 2 Component (without enclosure)

Certificate Baseefa09ATEX0094U

Standards EN IEC 60079-0:2018, EN 60079-7:2015 + A1:2018, EN 60079-15:2010

Markings  II 3G Ex nA IIC T4 Gc (-50 °C ≤ T_a ≤ +85 °C) or Ex nA IIC T5 Gc (-50 °C ≤ T_a ≤ +70 °C), Ex ec IIC T4 Gc (-50 °C ≤ T_a ≤ +85 °C) or Ex ec IIC T5 Gc (-50 °C ≤ T_a ≤ +70 °C)

Schedule of Limitations (U):

- The equipment must only be installed in an area of pollution degree 2 or better, as defined in IEC 60664-1, and in an enclosure that provides a degree of protection of at least IP54 in accordance with EN 60079-0.
- Provision must be made, external to the component, to ensure the rated voltage of the component supply is not exceeded by transient disturbances of more than 40 percent.
- The electrical circuit is connected directly to earth; this must be taken into account when installing the apparatus.

6.4 International

6.4.1 I7 IECEx Intrinsic Safety

Certificate IECEx BAS 09.0030X

Standards IEC 60079-0:2017, IEC 60079-11:2011

Markings Ex ia IIC T4 Ga (-50 °C ≤ T_a ≤ +60 °C)

Special Conditions for Safe Use (X):

- The apparatus must be installed in an enclosure that provides a degree of protection of at least IP20. Non-metallic enclosures must be suitable to prevent electrostatic hazards and light alloy or zirconium enclosures must be protected from impact and friction when installed.
- The apparatus is not capable of withstanding the 500 V insulation test required by IEC 60079-11:2011, clause 6.3.13. This must be taken into account when installing the apparatus.

6.4.2 IG IECEx FISCO Intrinsic Safety

Certificate	IECEx BAS 09.0030X
Standards	IEC 60079-0:2017, IEC 60079-11:2011
Markings	Ex ia IIC T4 Ga (-50 °C ≤ T _a ≤ +60 °C)

Special Conditions for Safe Use (X):

1. The equipment must be installed in an enclosure that provides a degree of protection of at least IP20. Non-metallic enclosures must be suitable to prevent electrostatic hazards and light alloy or zirconium enclosures must be protected from impact and friction when installed.
2. The equipment is not capable of withstanding the 500 V insulation test required by EN 60079-11:2012, clause 6.3.13. This must be taken into account when installing the equipment.

FISCO (input)	Sensor field terminal (output)
U _i = 17.5 V	U _o = 12.5 V
I _i = 380 mA	I _o = 4.8 mA
P _i = 5.32 W	P _o = 15 mW
C _i = 2.1 nF	C _o = 1.2 μF
L _i = 0	L _o = 1 H

6.4.3 N7 IECEx Type n (with enclosure)

Certificate:	IECEx BAS 09.0032X
Standards:	IEC 60079-0:2017, IEC 60079-7:2017, IEC 60079-15:2010
Markings:	Ex nA IIC T5 Gc (-40 °C ≤ T _a ≤ +65 °C), Ex ec IIC T5 Gc (-40 °C ≤ T _a ≤ +65 °C)

Special Conditions for Safe Use (X):

1. The equipment must only be installed and used in an area of pollution degree 2 or better, as defined in IEC 60664-1.
2. Provision must be made, external to the apparatus, to ensure the rated voltage of the apparatus supply is not exceeded by transient disturbances of more than 40 percent.
3. The electrical circuit is connected directly to earth. This must be taken into account when installing the apparatus.

6.4.4 NJ IECEx Type n (without enclosure)

Certificate: IECEx BAS 09.0031U

Standards: IEC 60079-0:2017, IEC 60079-7:2017, IEC 60079-15:2010

Markings: Ex nA IIC T4 Gc(-50 °C ≤ T_a ≤ +85 °C), Ex nA IIC T5 Gc (-50 °C ≤ T_a ≤ +70 °C), Ex ec IIC T4 Gc(-50 °C ≤ T_a ≤ +85 °C), Ex ec IIC T5 Gc (-50 °C ≤ T_a ≤ +70 °C)

Schedule of Limitations (U):

1. The component must be only installed and used in an area of pollution degree 2 or better, as defined in IEC 60664-1, and in an enclosure that provides a degree of protection of at least IP54 in accordance with IEC 60079-0
2. Provision must be made, external to the component, to ensure the rated voltage of the component supply is not exceeded by transient disturbances of more than 40 percent.
3. The electrical circuit is connected directly to earth; this must be taken into account when installing the apparatus.

6.5 Brazil

6.5.1 I2 INMETRO Intrinsic Safety

Certificate UL-BR 16.0086X

Standards ABNT NBR IEC 60079-0:2008 + Errata 1:2011 ABNT NBR IEC 60079-11:2009

Markings Ex ia IIC T4(-50 °C ≤ T_a ≤ +60 °C)

Special Conditions for Safe Use (X):

1. The apparatus must be installed in an enclosure that provides a degree of protection of at least IP20. Non-metallic enclosures must be suitable to prevent electrostatic hazards (see manufacturer's instructions manual) and light alloy or zirconium enclosures must be protected from impact and friction when installed.
2. The apparatus is not capable of withstanding the 500 V isolation test required by ABNT NBR IEC 60079-11. This must be taken into account when installing the apparatus --- see manufacturer's instructions manual.

Fieldbus (input)	Sensor field terminal (output)
U _i = 30 V	U _O = 12.5 V
I _i = 300 mA	I _O = 4.8 mA

Fieldbus (input)	Sensor field terminal (output)
$P_i = 1.3 \text{ W}$	$P_o = 15 \text{ mW}$
$C_i = 2.1 \text{ nF}$	$C_o = 1.2 \text{ }\mu\text{F}$
$L_i = 0$	$L_o = 1 \text{ H}$

6.5.2 IB INMETRO Intrinsic Safety

Certificate UL-BR 16.0086X

Standards ABNT NBR IEC 60079-0:2008 + Errata 1:2011, ABNT NBR IEC 60079-11:2009

Markings Ex ia IIC T4(-50 °C ≤ T_a ≤ +60 °C)

Special Conditions for Safe Use (X):

1. The apparatus must be installed in an enclosure that provides a degree of protection of at least IP20. Non-metallic enclosures must be suitable to prevent electrostatic hazards (see manufacturer's instructions manual) and light alloy or zirconium enclosures must be protected from impact and friction when installed.
2. The apparatus is not capable of withstanding the 500 V isolation test required by ABNT NBR IEC 60079-11. This must be taken into account when installing the apparatus --- see manufacturer's instruction manual.

FISCO (input)	Sensor field terminal (output)
$U_i = 17.5 \text{ V}$	$U_o = 12.5 \text{ V}$
$I_i = 380 \text{ mA}$	$I_o = 4.8 \text{ mA}$
$P_i = 5.32 \text{ W}$	$P_o = 15 \text{ mW}$
$C_i = 2.1 \text{ nF}$	$C_o = 1.2 \text{ }\mu\text{F}$
$L_i = 0$	$L_o = 1 \text{ H}$

6.6 China

6.6.1 I3 NEPSI Intrinsic Safety

Certificate GYJ16.1205X

Standards GB3836.1-2010, GB3836.4-2010, GB3836.20-2010

Markings Ex ia IIC T4/T5 Ga

产品安全使用特殊条件：

产品防爆合格证后缀“X”代表产品安全使用有特殊条件：

输出为 FOUNDATION Fieldbus 时：

1. 温度变送器须安装于外壳防护等级不低于国家标准 GB4208-2008 规定的 IP20 的壳体中，方可用于爆炸性危险场所，金属壳体须符合国家标准 GB3836.1-2010 第 8 条的规定，非金属壳体须符合 GB3836.1-2010 第 7.4 条的规定。
2. 此设备不能承受 GB3836.4-2010 标准中第 6.3.12 条规定的 500V 交流有效值试验电压的介电强度试验。

输出为 Wireless 时：

1. 天线的表面电阻大于 $1\text{ G}\Omega$ ，不允许用溶剂清洗或用干布擦拭，以避免电荷积聚。
2. 电源模块表面电阻大于 $1\text{ G}\Omega$ ，必须置于无线设备外壳内使用，现场安装及运输过程中避免电荷积聚。
3. 产品需使用厂家提供的由 2 块 Tadiran TL-5920 Lithium Thionyl-Chloride 原电池组成的电池组。

产品使用注意事项：

1. 产品环境温度为：

输出代码	温度组别	环境温度
F	T4	$50\text{ }^{\circ}\text{C} \leq \text{Ta} \leq + 60\text{ }^{\circ}\text{C}$
W	T4	$-60\text{ }^{\circ}\text{C} \leq \text{Ta} \leq + 70\text{ }^{\circ}\text{C}$
	T5	$-60\text{ }^{\circ}\text{C} \leq \text{Ta} \leq + 40\text{ }^{\circ}\text{C}$

2. 参数：

供电端 (1-2)

输出代码	最高输入电压	最大输入电流	最大输入功率	最大内部等效参数	
	U_i (V)	I_i (mA)	P_i (mW)	C_i (μF)	L_i (H)
F	30	300	1.3	2.1	0
F (FISCO)	17.5	380	5.32	2.1	0

注 1：上表中非 FISCO 参数必须来自于使用电阻限流的线性输出。

注 2：本安电气参数符合 GB3836.19-2010 对 FISCO 现场仪表的参数要求。当其连接符合 FISCO 模型的电路板时，其本安参数及内部最大等效参数见上表。

传感器端：

输出代码	端子	最高输出电压	最大输出电流	最大输出功率	最大外部等效参数	
		U _o (V)	I _o (mA)	P _o (mW)	C _o (μH)	L _o (H)
F	1-8	12.5	4.8	15	1.2	1
F (FISCO)	1-20	6.6	3.2	5.3	22	1

- 输出代码为 F 时，该产品必须与已通过防爆认证的关联设备配套共同组成本防爆系统方可使用于爆炸性气体环境。其系统接线必须同时遵守本产品 and 所配关联设备的使用说明书要求，接线端子不得接错。
- 该产品于关联设备的连接电缆应为带绝缘护套的屏蔽电缆，其屏蔽层应为安全接地。
- 用户不得自行更换该产品的零部件，应会同产品制造商共同解决运行中出现的故障，以杜绝损坏现象的发生。产品的安装、使用和维修应同时遵守产品使用说明书、GB3836.13-2013“爆炸性环境 第 13 部分：设备的修理、检修、修复和改造”、GB3836.15-2000“爆炸性气体环境用电气设备 第 15 部分：危险场所电气安装（煤矿除外）”、GB3836.16-2006“爆炸性气体环境用电气设备 第 16 部分：电气装置的检查和维护（煤矿除外）”、GB3836.18-2010“爆炸性环境 第 18 部分：本质安全系统”和 GB50257-2014“电气装置安装工程爆炸和火灾危险环境电力装置施工及验收规范”的有关规定。

6.6.2 N3 NEPSI Type n

Certificate	Gyj17.1008U
Standards	GB3836.1-2010, GB3836.8-2014
Markings	Ex nA nL IIC T4/T5 Gc

产品安全使用特殊条件：

- 设备不能承受 GB3836.8-2014 标准中第 6.5.1 条规定的 500V 耐压试验，安装时必须考虑在内。
- 此设备必须安装于具有不低于 IP54 外壳防护等级的 Ex 元件外壳，外壳应符合 GB3836.1-2010 和 GB3836.8-2014 标准对外壳材料和环境的相关要求。
- 在此设备外部应采取措​​施以防额定电压因瞬态干扰而超过 40%。

产品使用注意事项：

- 产品使用环境温度范围：

温度组别	环境温度
T4	$-50^{\circ}\text{C} \leq T_a \leq +85^{\circ}\text{C}$
T5	$-50^{\circ}\text{C} \leq T_a \leq +70^{\circ}\text{C}$

2. 最高工作电压：42.4V。
3. 用户不得自行更换该产品的零部件，应会同产品制造商共同解决运行中出现的故障，以杜绝损坏现象的发生。
4. 产品的安装、使用和维护应同时遵守产品使用说明书、GB3836.13-2013“爆炸性环境 第 13 部分：设备的修理、检修、修复和改造”、GB3836.15-2000“爆炸性气体环境用电气设备 第 15 部分：危险场所电气安装（煤矿除外）”、GB3836.16-2006“爆炸性气体环境用电气设备 第 16 部分：电气装置的检查和维护（煤矿除外）”、B50257-2014“电气装置安装工程爆炸和火灾危险环境电力装置施工及验收规范”的有关规定。

6.7 Japan

6.7.1 I4 TIIS FISCO Intrinsic Safety (ia)

Certificate	TC19713
Markings	ia IIC T4

6.7.2 TIIS Wi-HART Intrinsic Safety (ia)

Certificate	TC19154
Markings	ia IIC T4

6.7.3 H4 TIIS FISCO Intrinsic Safety (ib)

Certificate	TC20737
Markings	ia IIC T4

6.8 Korea

6.8.1 IP Korea Intrinsic Safety

Certificate	10-KB4BO-0088X
Markings	Ex ia IIC T4 ($-50^{\circ}\text{C} \leq T_a \leq +60^{\circ}\text{C}$)

6.9 EAC - Belarus, Kazakhstan, Russia

6.9.1 IM Technical Regulation Customs Union (EAC) Intrinsic Safety

Markings [FOUNDATION Fieldbus]: 0Ex ia IIC T4 Ga X, T4(-50 °C ≤ T_a ≤ +60 °C)

See certificate for entity parameters.

Special Condition for Safe Use (X):

See certificate for special conditions.

6.9.2 IN Technical Regulation Customs Union (EAC) FISCO

Markings: [FISCO]: 0Ex ia IIC T4 Ga X, T4(-50 °C ≤ T_a ≤ +60 °C)

See certificate for entity parameters.

Special Condition for Safe Use (X):

See certificate for special conditions.

6.10 Combinations

KG Combination of I1/IA, I5/IE, I6/IF, and I7/IG

6.11 Conduit Plugs and Adapters

ATEX Flameproof and Increased Safety

Certificate FM13ATEX0076X

Standards EN 60079-0:2012, EN 60079-1:2007, IEC 60079-7:2007

Markings:  2 G Ex de IIC Gb

Special Conditions for Safe Use (X):

1. When the thread adapter or blanking plug is used with an enclosure in type of protection increased safety “e” the entry thread shall be suitably sealed in order to maintain the ingress protection rating (IP) of the enclosure.
2. The blanking plug shall not be used with an adapter.
3. Blanking Plug and Threaded Adapter shall be either NPT or Metric thread forms. G½ and PG 13.5 thread forms are only acceptable for existing (legacy) equipment installations.

IECEx Flameproof and Increased Safety

Certificate IECEx FMG 13.0032X

Standards IEC 60079-0:2011, IEC 60079-1:2007, IEC 60079-7:2006-2007

Markings Ex de IIC Gb

Special Conditions for Safe Use (X):

1. When the thread adapter or blanking plug is used with an enclosure in type of protection increased safety “e” the entry thread shall be suitably sealed in order to maintain the ingress protection rating (IP) of the enclosure.
2. The blanking plug shall not be used with an adapter.
3. Blanking Plug and Threaded Adapter shall be either NPT or Metric thread forms. G½ and PG 13.5 thread forms are only acceptable for existing (legacy) equipment installations.

Table 6-2: Conduit Plug Thread Sizes

Thread	Identification mark
M20 x 1.5	M20
½–14 NPT	½ NPT
G½	G½

Table 6-3: Thread Adapter Thread Sizes

Male thread	Identification mark
M20 x 1.5–6H	M20
½–14 NPT	½–14 NPT
¾–14 NPT	¾–14 NPT
Female thread	Identification mark
M20 x 1.5–6H	M20
½–14 NPT	½–14 NPT
PG 13.5	PG 13.5

6.12 Additional certifications

6.12.1 SBS American Bureau of Shipping (ABS) Type Approval

Certificate 16-HS1553096-PDA

ABS Rules 2013 Steel Vessels Rules 1-1-4/7.7, 1-1-Appendix 3, 4-8-3/1.7, 4-8-3/13.1

6.12.2 SBV Bureau Veritas (BV) Type Approval

Certificate 26325 BV

Requirements Bureau Veritas Rules for the Classification of Steel Ships

Application Class notations: AUT-UMS, AUT-CCS, AUT-PORT and AUT-IMS

6.12.3 SDN Det Norske Veritas (DNV) Type Approval

Certificate TAA00000K8

Intended Use Det Norske Veritas' Rules for Classification of Ships, High Speed & Light Craft and Det Norske Veritas' Offshore Standards

Application

Location classes	
Temperature	D
Humidity	B
Vibration	A
EMC	A
Enclosure	B/IP66: AI C/IP66: SST

6.12.4 SLL Lloyds Register (LR) Type Approval

Certificate 11/60002

Application Environmental categories ENV1, ENV2, ENV3, and ENV5

7 Declaration of conformity

	
<h2 style="margin: 0;">EU Declaration of Conformity</h2> <p style="margin: 0;">No: RMD 1047 Rev. M</p> <hr style="border: 1px solid black;"/>	
<p>We,</p> <p style="margin-left: 40px;">Rosemount, Inc. 8200 Market Boulevard Chanhassen, MN 55317-9685 USA</p>	
<p>declare under our sole responsibility that the product,</p> <p style="text-align: center;">Rosemount™ Model 848T Temperature Transmitter</p> <p>manufactured by,</p> <p style="margin-left: 40px;">Rosemount, Inc. 8200 Market Boulevard Chanhassen, MN 55317-9685 USA</p>	
<p>to which this declaration relates, is in conformity with the provisions of the European Union Directives, including the latest amendments, as shown in the attached schedule.</p> <p>Assumption of conformity is based on the application of the harmonized standards and, when applicable or required, a European Union notified body certification, as shown in the attached schedule.</p>	
 <hr style="border: 0.5px solid black;"/> <p>(signature)</p>	<p>Vice President of Global Quality</p> <hr style="border: 0.5px solid black;"/> <p>(function)</p>
<p>Chris LaPoint</p> <hr style="border: 0.5px solid black;"/> <p>(name)</p>	<p>1-Feb-19; Shakopee, MN USA</p> <hr style="border: 0.5px solid black;"/> <p>(date of issue & place)</p>
<p>Page 1 of 2</p>	



EU Declaration of Conformity

No: RMD 1047 Rev. M

EMC Directive (2014/30/EU)

Harmonized Standards: EN 61326-1:2013, EN 61326-2-3: 2013

ATEX Directive (2014/34/EU)

Baseefa 09ATEX0093X – Intrinsically Safe Certificate

Equipment Group II, Category 1 G (Ex ia IIC T4 Ga)

Harmonized Standards:

EN IEC 60079-0: 2018; EN 60079-11: 2012

ATEX Notified Bodies for EC Type Examination Certificate

SGS FIMCO OY [Notified Body Number: 0598]

P.O. Box 30 (Särkiniementie 3)

00211 HELSINKI

Finland

ATEX Notified Body for Quality Assurance

SGS FIMCO OY [Notified Body Number: 0598]

P.O. Box 30 (Särkiniementie 3)

00211 HELSINKI

Finland

8 China RoHS

含有 China RoHS 管控物质超过最大浓度限值的部件型号列表 848T
List of 848T Parts with China RoHS Concentration above MCVs

部件名称 Part Name	有害物质 / Hazardous Substances					
	铅 Lead (Pb)	汞 Mercury (Hg)	镉 Cadmium (Cd)	六价铬 Hexavalent Chromium (Cr +6)	多溴联苯 Polybrominated biphenyls (PBB)	多溴联苯醚 Polybrominated diphenyl ethers (PBDE)
电子组件 Electronics Assembly	X	O	O	O	O	O
壳体组件 Housing Assembly	O	O	O	X	O	O
传感器组件 Sensor Assembly	X	O	O	O	O	O

本表格系依据 SJ/T11364 的规定而制作。

This table is proposed in accordance with the provision of SJ/T11364.

O: 意为该部件的所有均质材料中该有害物质的含量均低于 GB/T 26572 所规定的限量要求。

O: Indicate that said hazardous substance in all of the homogeneous materials for this part is below the limit requirement of GB/T 26572.



X: 意为在该部件所使用的的所有均质材料里，至少有一类均质材料中该有害物质的含量高于 GB/T 26572 所规定的限量要求。

X: Indicate that said hazardous substance contained in at least one of the homogeneous materials used for this part is above the limit requirement of GB/T 26572.

部件名称 Part Name	组装备件说明 Spare Parts Descriptions for Assemblies
电子组件 Electronics Assembly	端子块组件 Terminal Block Assemblies
壳体组件 Housing Assembly	电子外壳 Electrical Housing



Global Headquarters

Emerson Automation Solutions
6021 Innovation Blvd.
Shakopee, MN 55379, USA
 +1 800 999 9307 or +1 952 906 8888
 +1 952 204 8889
 RFQ.RMD-RCC@Emerson.com

North America Regional Office

Emerson Automation Solutions
8200 Market Blvd.
Chanhassen, MN 55317, USA
 +1 800 999 9307 or +1 952 906 8888
 +1 952 204 8889
 RMT-NA.RCCRFQ@Emerson.com



Latin America Regional Office

Emerson Automation Solutions
1300 Concord Terrace, Suite 400
Sunrise, FL 33323, USA
 +1 954 846 5030
 +1 954 846 5121
 RFQ.RMD-RCC@Emerson.com

Europe Regional Office

Emerson Automation Solutions Europe
GmbH
Neuhofstrasse 19a P.O. Box 1046
CH 6340 Baar
Switzerland
 +41 (0) 41 768 6111
 +41 (0) 41 768 6300
 RFQ.RMD-RCC@Emerson.com

Asia Pacific Regional Office

Emerson Automation Solutions
1 Pandan Crescent
Singapore 128461
 +65 6777 8211
 +65 6777 0947
 Enquiries@AP.Emerson.com

Middle East and Africa Regional Office

Emerson Automation Solutions
Emerson FZE P.O. Box 17033
Jebel Ali Free Zone - South 2
Dubai, United Arab Emirates
 +971 4 8118100
 +971 4 8865465
 RFQ.RMTMEA@Emerson.com

 [Linkedin.com/company/Emerson-Automation-Solutions](https://www.linkedin.com/company/Emerson-Automation-Solutions)

 [Twitter.com/Rosemount_News](https://twitter.com/Rosemount_News)

 [Facebook.com/Rosemount](https://www.facebook.com/Rosemount)

 [Youtube.com/user/RosemountMeasurement](https://www.youtube.com/user/RosemountMeasurement)

©2020 Emerson. All rights reserved.

Emerson Terms and Conditions of Sale are available upon request. The Emerson logo is a trademark and service mark of Emerson Electric Co. Rosemount is a mark of one of the Emerson family of companies. All other marks are the property of their respective owners.