

# Fisher™ EHD, EHS, and EHT Valves NPS 1-1/2x1 through NPS 8x6

## Contents

- Introduction ..... 1
- Scope of Manual ..... 1
- Description ..... 2
- Specifications ..... 3
- Educational Services ..... 3
- Installation ..... 4
- Maintenance ..... 6
- Packing Lubrication ..... 7
- Packing Maintenance ..... 7
- Replacing Packing ..... 8
- Trim Removal ..... 12
- Valve Plug Maintenance ..... 14
- Lapping Seats ..... 15
- Trim Replacement ..... 16
- Retrofit: Installing C-seal Trim ..... 21
- Replacement of Installed C-seal Trim ..... 24
- Trim Removal (C-seal Constructions) ..... 24
- Lapping Metal Seats (C-seal Constructions) .. 26
- Remachining Metal Seats (C-seal Constructions) ..... 26
- Trim Replacement (C-seal Constructions) ... 26
- Parts Ordering ..... 28
- Parts Kits ..... 28
- Parts List ..... 29

Figure 1. Fisher EH Valve with 657 Actuator



## Introduction

### Scope of Manual

This instruction manual includes installation, maintenance, and parts information for the Fisher EHD, EHS, and EHT control valves in NPS 1-1/2 x 1 through NPS 8x6. Refer to separate manuals for instructions covering the actuator, positioner, ENVIRO-SEAL™ packing, HIGH-SEAL packing, and accessories.

Do not install, operate, or maintain EHD, EHS, or EHT valves without being fully trained and qualified in valve, actuator, and accessory installation, operation, and maintenance. To avoid personal injury or property damage, it is important to carefully read, understand, and follow all the contents of this manual, including all safety cautions and warnings. If you have any questions about these instructions, contact your [Emerson sales office](#) or Local Business Partner before proceeding.

Unless otherwise noted, all NACE references are to NACE MR0175-2002.

Table 1. Specifications

<p><b>End Connection Styles</b></p> <p><b>Buttwelding:</b> All available ASME B16.25 schedules that are compatible with ASME B16.34 pressure/temperature ratings</p> <p><b>Flanged:</b> CL2500 ■ ring-type joint (RTJ) or ■ raised-face (RF) flanges according to ASME B16.5</p> <p><b>Socket Welding:</b> Consistent with ASME B16.11</p> <p><b>Maximum Inlet Pressure<sup>(1)</sup></b></p> <p><b>Buttwelding:</b> Consistent with CL2500 pressure-temperature ratings per ASME B16.34</p> <p><b>Flanged:</b> Consistent with CL2500 pressure-temperature ratings per ASME B16.34</p> <p><b>Socket Welding:</b> Consistent with CL2500 pressure-temperature ratings per ASME B16.34</p> <p><b>Shutoff Classifications</b></p> <p>See table 2</p> <p><b>C-seal trim:</b> High-temperature, Class V.</p> <p>See table 3</p> <p><b>TSO (Tight Shutoff) trim:</b> See tables 4 and 5</p>	<p><b>Flow Characteristic</b></p> <p><b>Standard Cage:</b> ■ Equal percentage, ■ modified equal percentage<sup>(2)</sup>, ■ or linear</p> <p><b>Cavitrol™ III or Whisper Trim™ III Cage:</b> Linear</p> <p><b>Flow Direction</b></p> <p><b>EHD or EHT:</b> Flow down, except with either a Whisper Trim III cage or a valve plug with diverter cone, both of which are flow up</p> <p><b>EHS:</b> Flow up, except flow down with Cavitrol III cage</p> <p><b>Approximate Weights (Valve Body and Bonnet Assemblies)</b></p> <p>See table 6</p> <p><b>Additional Specifications</b></p> <p>For specifications such as materials, valve plug travels, and port, yoke boss, and stem diameters, see the Parts List section</p>
--	---

1. The pressure or temperature limits in this manual and any applicable standard limitations should not be exceeded.

2. Modified equal percentage characteristic is equal-percentage for the first 90% of travel, then quick-opening for additional capacity.

Table 2. Shutoff Classifications per ANSI/FCI 70-2 and IEC 60534-4

Valve	Valve Size, NPS	ANSI/FCI Leakage Class
EHD	3x2	II
	3, 4x3, 4, 6x4	II—Standard
		III—Optional <sup>(1)</sup>
	6, 8x6	III—Standard
IV—Optional <sup>(1)</sup>		
EHS w/Cavitrol III, or EHT w/Cavitrol III	All	V <sup>(1)</sup>
EHS, EHT, EHS w/Micro-Form or EHS w/Micro Flute	All	IV—Standard
		V—Optional <sup>(1)</sup>
EHT w/ PEEK Anti-Extrusion Rings	3 to 6	V to 600°F (316°C)

1. O-ring seat ring construction recommended for this shutoff classification; for temperatures below 232°C (450°F) only.

## Description

The EHD, EHS, and EHT high-pressure globe valves (figure 1) have metal seats, cage guiding, and push-down-to-close valve plug action. The EHD and EHT valves use balanced valve plugs.

The EHS valve uses an unbalanced valve plug. To provide a seal between the cage and a balanced valve plug, the EHD valve plug uses piston rings; the EHT valve plug uses a pressure-assisted seal ring. A Whisper Trim cage can be used with an EHD, EHS, or EHT valve plug. A Cavitrol III cage can be used with an EHS or EHT valve plug.

C-seal trim is available for EHD valves, CL2500, in sizes 4, 6, 6x4, and 8x6.

With C-seal trim, a balanced valve can achieve high-temperature, Class V shutoff. Because the C-seal plug seal is formed from metal (N07718 nickel alloy) rather than an elastomer, a valve equipped with the C-seal trim can be

applied in processes with a fluid temperature of up to 593°C (1100°F), provided other material limits are not exceeded. Contact your [Emerson sales office](#) or Local Business Partner for information.

## Specifications

Specifications for the EHD, EHS, and EHT valves are shown in table 1.

## Educational Services

For information on available courses for the Fisher EH valve, as well as a variety of other products, contact:

Emerson Automation Solutions  
 Educational Services - Registration  
 Phone: 1-641-754-3771 or 1-800-338-8158  
 E-mail: [education@emerson.com](mailto:education@emerson.com)  
[emerson.com/fishervalvetraining](http://emerson.com/fishervalvetraining)

Table 3. Additional Shutoff Classification per ANSI/FCI 70-2 and IEC 60534-4

Valve (Class)	Valve Size, NPS	Port Diameter, Inches	Cage Style	ANSI/FCI Leakage Class
EHD (CL2500)	4 6x4	2.875	Equal Percentage, Modified Equal Percentage, Linear (std. cage), Linear (Whisper III, A1, B3, C3) Linear (Cavitrol III, 2-stage)	V (for port diameters from 2.875 through 7-inch with optional C-seal trim)
	6 8x6	4.375	Equal Percentage, Modified Equal Percentage, Linear (std. cage), Linear (Whisper III, A1, B3, C3, D3)	
	6 8x6	4.375	Linear (Cavitrol III, 2- and 3-stage)	

Table 4. TSO (Tight Shutoff) Leakage Class per ANSI/FCI 70-2 and IEC 60534-4

Leakage Class	Maximum Leakage	Test Medium	Test Pressure	ANSI/FCI Leakage Class
TSO (Tight Shutoff)	Valves with TSO trim are factory tested to a more stringent Emerson Automation Solutions test requirement of no leakage at time of shipment.	Water	Service ΔP <sup>(1)</sup>	V

1. Specify service ΔP when ordering.

Table 5. TSO Shutoff Availability

VALVE	CONSTRUCTION	LEAKAGE CLASS	
		Standard	Optional
EHS, EHT	Cavitrol III trim. Replaceable, protected soft seat	TSO	---

Table 6. Approximate Weights (Valve Body and Bonnet Assemblies)

VALVE SIZE, NPS	CL2500			
	Kilograms		Pounds	
	Flg	SWE & BWE	Flg	SWE & BWE
1-1/2 x 1	---	46	---	101
2x1	78	47	173	104
3x2	161	94	355	207
3	223	163	492	359
4x3	265	162	585	357
4	338	243	745	536
6x4	526	257	1160	567
6	785	544	1731	1199
8x6	955	558	2106	1231

## Installation

### **⚠ WARNING**

Always wear protective gloves, clothing, and eyewear when performing any installation operations to avoid personal injury.

To avoid personal injury or property damage resulting from the sudden release of pressure, do not install the valve assembly where service conditions could exceed the limits given in this manual or on the appropriate nameplates. Use pressure-relieving devices as required by government or accepted industry codes and good engineering practices.

Check with your process or safety engineer for any additional measures that must be taken to protect against process media.

If installing into an existing application, also refer to the WARNING at the beginning of the Maintenance section in this instruction manual.

### **CAUTION**

Responsibility for the safety of process media and compatibility of valve materials with process media rests solely with the purchaser and end-user. The valve configuration and construction materials meet particular pressure, temperature, pressure drop, and controlled fluid conditions specified in the customer's order. Because some body/trim material combinations are limited in their pressure drop and temperature range capabilities (especially due to differences in thermal expansion rates), do not apply any other conditions to the valve without first contacting your [Emerson sales office](#) or Local Business Partner.

### **CAUTION**

If hoisting the valve, use a nylon sling to protect the painted surfaces. Carefully position the sling to prevent damage to the tubing or any accessories. Use adequately sized hoists and chains or slings to handle the valve and take precautions to prevent personnel from being injured in case the hoist or rigging slips unexpectedly. Refer to table 6 for valve assembly weights.

### **⚠ WARNING**

Personal injury could result from packing leakage. Valve packing was tightened prior to shipment; however some readjustment will be required to meet specific service conditions. Check with your process or safety engineer for any additional measures that must be taken to protect against process media.

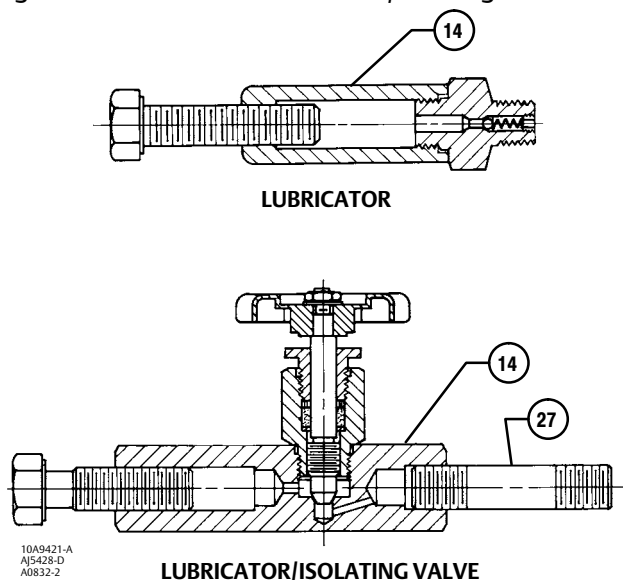
1. Before installing the valve, inspect it to ensure that the valve body cavity is free of foreign material.
2. Clean out all pipelines to remove scale, welding slag, and other foreign materials before installing the valve.

#### **Note**

If the valve being installed has small internal flow passages, such as with Whisper Trim III or Cavitrol III cages, consideration should be given to installing an upstream strainer to prevent the lodging of particles in these passages. This is especially important if the pipeline cannot be thoroughly cleaned or if the flowing medium is not clean.

3. The control valve must be installed with the actuator vertical above the valve body for proper operation. Flow through the valve must be in the direction indicated by the flow arrow (key 15, figure 18, 19, or 20) on the valve body.
4. Use accepted piping and welding practices when installing the valve in the line. For welding end valve bodies, completely disassemble the valve removing all trim parts before welding the valve body in the line. For flanged valve bodies, use suitable gaskets between the valve body flanges and pipeline flanges.

Figure 2. Lubricator and Lubricator/Isolating Valve



**CAUTION**

Depending on valve body materials used, post-weld heat treating might be needed. Post-weld heat treatment can damage internal elastomeric, plastic, and metal parts. Shrink-fit pieces and threaded connections might loosen.

If post-weld heat treating is needed, remove all trim parts to avoid any damage to internal elastomeric, plastic, and metal parts. Contact your [Emerson sales office](#) or Local Business Partner for additional information.

5. Install a three-valve bypass around the valve if continuous operation is required during maintenance.
6. If the actuator and valve body are shipped separately, refer to the actuator mounting procedure in the appropriate actuator instruction manual.
7. If the valve was shipped without packing installed in the packing box, install the packing before putting the valve into service. Refer to instructions given in the Packing Maintenance procedure.

Valves with ENVIRO-SEAL live-loaded packing or HIGH-SEAL Heavy-Duty live-loaded packing will not require this initial re-adjustment. See the Fisher instruction manuals titled ENVIRO-SEAL Packing System for Sliding-Stem Valves ([D101642X012](#)) or HIGH-SEAL Live-Loaded Packing System ([D101453X012](#)) (as appropriate) for packing instructions. If you wish to convert your present packing arrangement to ENVIRO-SEAL packing, refer to the retrofit kits listed in the parts kit sub-section near the end of this manual.

## Maintenance

Valve parts are subject to normal wear and must be inspected and replaced as necessary. Inspection and maintenance frequency depends on the severity of service conditions. This section includes instructions for packing lubrication, packing maintenance, adding packing rings, replacing packing, trim removal, valve plug maintenance, lapping seats, and trim replacement. All maintenance operations can be performed with the valve in the line.

### ⚠ WARNING

**Avoid personal injury from sudden release of process pressure. Before performing any maintenance operations:**

- Do not remove the actuator from the valve while the valve is still pressurized.
- Always wear protective gloves, clothing, and eyewear when performing any maintenance operations to avoid personal injury.
- Disconnect any operating lines providing air pressure, electric power, or a control signal to the actuator. Be sure the actuator cannot suddenly open or close the valve.
- Use bypass valves or completely shut off the process to isolate the valve from process pressure. Relieve process pressure on both sides of the valve. Drain the process media from both sides of the valve.
- Vent the power actuator loading pressure and relieve any actuator spring precompression.
- Use lock-out procedures to be sure that the above measures stay in effect while you work on the equipment.
- The valve packing box may contain process fluids that are pressurized, *even when the valve has been removed from the pipeline*. Process fluids may spray out under pressure when removing the packing hardware or packing rings, or when loosening the packing box pipe plug.
- Check with your process or safety engineer for any additional measures that must be taken to protect against process media.

Table 7. Recommended Torque for Packing Flange Nuts

STEM DIAMETER		VALVE BODY RATING(1)	TORQUE			
			N•m		Lbf•Ft	
mm	Inches		Min	Max	Min	Max
12.7	1/2	CL1500	15	22	11	16
		CL2500	18	24	13	18
19.1	3/4	CL1500	34	50	25	37
		CL2500	41	61	30	45
25.4	1	CL1500	52	77	38	57
		CL2500	61	91	45	67
31.8	1-1/4	CL1500	68	102	50	75
		CL2500	81	122	60	90

1. Includes intermediate class ratings.

### Note

Whenever a gasket seal is disturbed by removing or shifting gasketed parts, a new gasket should be installed upon reassembly. This is necessary to ensure a good gasket seal.

### Note

If the valve has ENVIRO-SEAL live-loaded packing installed (figure 3), see the Fisher instruction manual entitled ENVIRO-SEAL Packing System for Sliding-Stem Valves ([D101642X012](#)) for packing instructions.

If the valve has HIGH-SEAL heavy-duty live-loaded packing installed, see Fisher instruction manual entitled HIGH-SEAL Live-Loaded Packing System ([D101453X012](#)) for packing instructions.

**⚠ WARNING**

Personal injury could result from packing leakage. Valve packing was tightened prior to shipment; however some readjustment will be required to meet specific service conditions. Check with your process or safety engineer for any additional measures that must be taken to protect against process media.

## Packing Lubrication

**CAUTION**

Do not lubricate graphite packing. Graphite packing is self-lubricated. Additional lubrication may result in slip-stick movement of the valve.

**⚠ WARNING**

To avoid personal injury or property damage resulting from fire or explosion, do not lubricate packing used in oxygen service or in processes with temperatures over 260°C (500°F).

A lubricator or lubricator/isolating valve (figure 2) is recommended for PTFE-composition packing. The lubricator or lubricator/isolating valve is installed in place of the pipe plug (key 14, figure 16). It is recommended that a good quality silicon-base lubricant be used. To operate the lubricator, simply turn the cap screw clockwise to force lubricant into the packing box. The lubricator/isolating valve operates the same way except the isolating valve must first be opened and then closed after lubrication is completed.

## Packing Maintenance

If there is undesirable packing leakage in spring-loaded PTFE V-ring packing (figure 4), tighten the packing flange nuts (key 5, figure 16) until the shoulder on the packing follower (key 13, figure 16) contacts the bonnet (key 1, figure 16). If leakage continues, replace the packing by following the numbered steps presented in the Replacing Packing procedure.

**CAUTION**

When tightening packing flange nuts, do not exceed the maximum recommended torque in table 7 or excessive friction may result, resulting in keeping the valve from stroking fully and not attaining proper seat load.

If there is undesirable packing leakage with other than spring-loaded PTFE V-ring packing, first try to limit the leakage and establish a stem seal by tightening the packing flange nuts (key 5, figure 16) to at least the minimum recommended torque in table 7. However, do not exceed the maximum recommended torque in table 7 or excessive friction may result. If leakage continues, replace the packing by following the numbered steps presented in the Replacing Packing procedure.

If the packing is relatively new and tight on the valve plug stem, and if tightening the packing flange nuts does not stop the leakage, it is possible that the stem is worn or nicked so that a seal cannot be made. The surface finish of a stem is critical for making a good packing seal. If the leakage comes from the outside diameter of the packing, it is possible that the leakage is caused by nicks or scratches around the packing box wall. While replacing the packing according to the Replacing Packing procedure, inspect the valve plug stem and packing box wall for nicks or scratches.

## Replacing Packing

Key numbers referred to in this procedure are shown in figure 16 unless otherwise indicated.

1. Isolate the control valve from the line pressure, release pressure from both sides of the valve body, and drain the process media from both sides of the valve.

Remove the cap screws in the stem connector, and separate the two halves of the stem connector. Then exhaust all actuator pressure, if any was applied, and disconnect the actuator supply and any leakoff piping.

2. Remove either the yoke locknut (key 15) or the hex nuts (key 26), and remove the actuator from the bonnet (key 1).
3. Loosen the packing flange nuts (key 5) so that the packing is not tight on the valve plug stem (key 4, figure 18, 19, or 20). Remove any travel indicator disk and stem locknuts from the valve plug stem threads.

Table 8. Torque for Body-to-Bonnet Bolting Using Anti-Seize Lubricant(1)

VALVE SIZE, NPS	VALVE BODY RATING	TORQUE			
		N•m		Lbf•Ft	
		B7, B16, BD and 660 Studs	B8 and B8M Studs	B7, B16, BD and 660 Studs	B8 and B8M Studs
1, 1-1/2 x 1, 2x1	CL1500	163	122	120	90
	CL2500	258	195	190	140
2, 3x2	CL1500	258	195	190	140
	CL2500	380	285	280	210
3, 4x3	CL1500	556	420	410	310
	CL2500	786	597	580	440
4, 6x4	CL1500	786	597	580	440
	CL2500	1058	800	780	590
6, 8x6	CL1500	1383	1044	1020	770
	CL2500	2807	2102	2070	1550

1. For other materials, contact your [Emerson sales office](#) or Local Business Partner for torques.

## CAUTION

When lifting the bonnet (key 1), be sure that the valve plug and stem assembly (keys 3 and 4, figure 18, 19, or 20) remains on the seat ring (key 6, figure 18, 19, or 20). This avoids damage to the seating surfaces as a result of the assembly dropping from the bonnet after being lifted part way out. The parts are also easier to handle separately.

Use care to avoid damaging gasket sealing surfaces.

The EHD piston rings (key 8, figure 18) are brittle and in two halves. Avoid damaging the piston rings by dropping or rough handling.

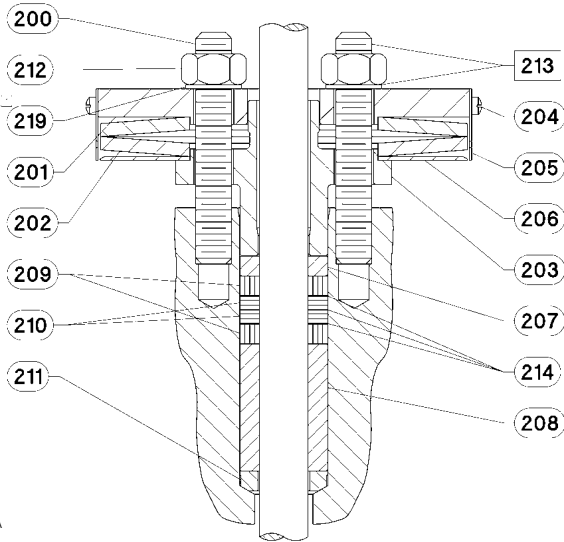
## WARNING

If the cage adheres to the bonnet as the bonnet is lifted, secure the cage to the bonnet so that it will not cause personal injury or equipment damage should it fall unexpectedly.

4. Unscrew the hex nuts (key 14, figure 18, 19, or 20) and carefully lift the bonnet off the valve stem. If present, remove the Belleville washers (key 33, figure 17) and flat washers (key 29, figure 18, 19, 17, or 20). If the valve plug and stem assembly starts to lift with the bonnet, use a brass or lead hammer on the end of the stem and tap it back down. Set the bonnet on a cardboard or wooden surface to prevent damage to the bonnet gasket surface.
5. Remove the valve plug (key 3, figure 18, 19, or 20), the cage (key 2, figure 18, 19, or 20), and the top and bottom cage gaskets (key 11, figure 18, 19, or 20).

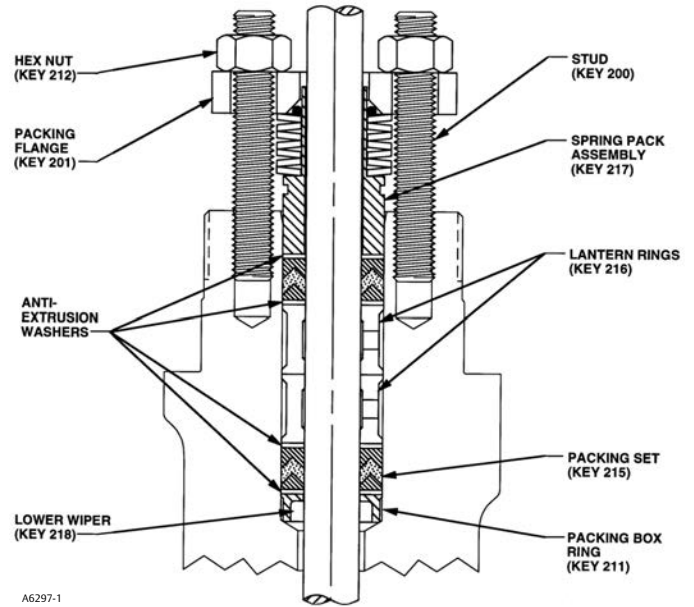


Figure 3. Live-Loaded Packing



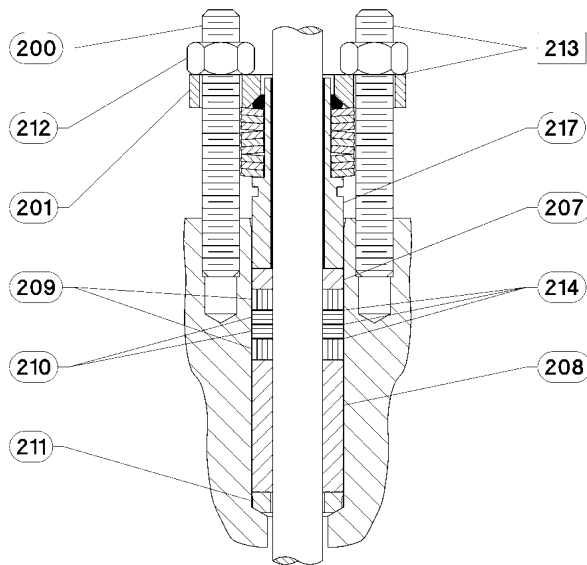
3984153-A

Typical HIGH-SEAL ULF Packing System



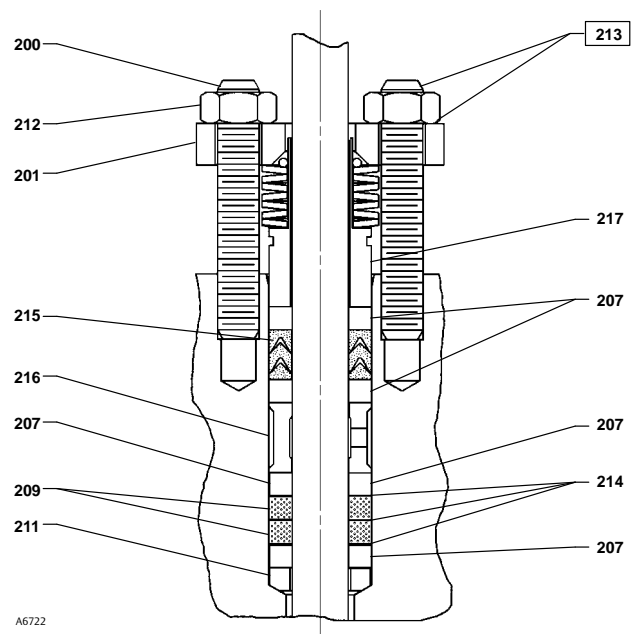
A6297-1

Typical ENVIRO-SEAL Packing System  
with PTFE Packing



3984612/A

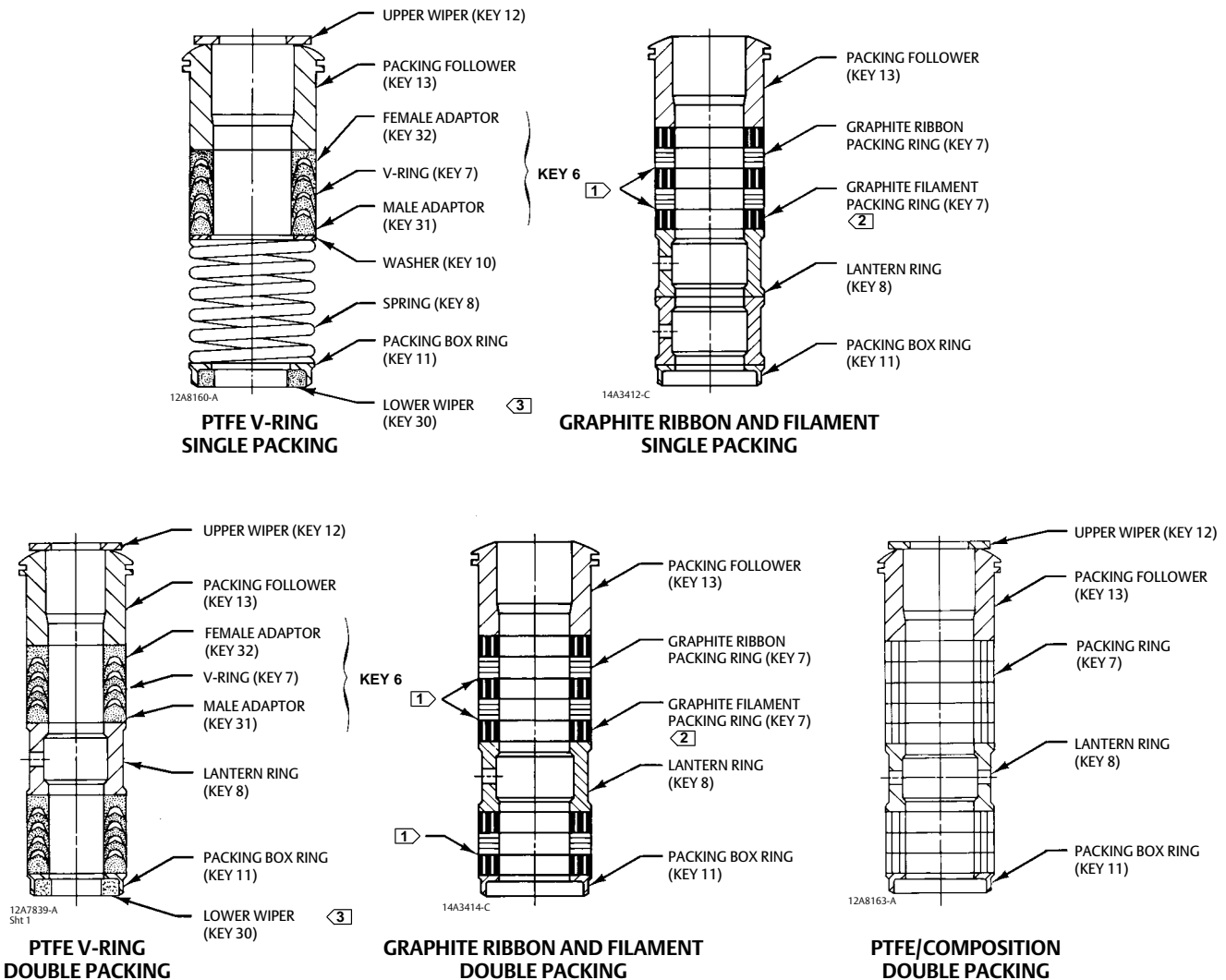
Typical ENVIRO-SEAL Packing System  
with Graphite ULF Packing



A6722

Typical ENVIRO-SEAL Packing System  
with Duplex Packing

Figure 4. Packing Arrangements



NOTES:  
 1 0.102 mm (0.004 INCH) THICK SACRIFICIAL ZINC WASHERS.  
 USE ONLY ONE BELOW EACH GRAPHITE RIBBON RING.

2 HAS THE APPEARANCE OF A WOVEN OR BRAIDED RING.  
 3 INCLUDED IN KEY 6 PACKING SET.

C0637-1

**CAUTION**

All residual gasket material must be removed from the cage gasket surfaces. If the gasket surfaces are scored or damaged during this process, smooth them by hand sanding with 360 grit paper using long, sweeping strokes. Failure to remove all residual gasket material and/or burrs from the gasket surfaces will result in leakage.

6. Clean all gasket surfaces with a good quality degreaser. Remove all residual tin or silver from all gasket surfaces.
7. Cover the opening in the valve body to protect the gasket surface and to prevent foreign material from getting into the valve body cavity.
8. Remove the packing flange nuts (key 5), packing flange (key 3), upper wiper (key 12), and packing follower (key 13, figures 4 and 16). Carefully push out all the remaining packing parts from the valve side of the bonnet using a

- rounded rod or other tool that will not scratch the packing box wall. For extension bonnets, also remove the baffle (key 2) and retaining ring (key 35).
9. Clean the packing box and the following metal packing parts: packing follower (key 13), packing box ring (key 11), spring or lantern ring (key 8, figures 4 and 16), and, for single arrangements of PTFE V-ring packing only, special washer (key 10, figures 4 and 16).
  10. Inspect the valve stem threads for any sharp edges that might cut the packing. A whetstone or emery cloth may be used to smooth the threads if necessary.
  11. Remove the protective covering from the valve body cavity. Using new top and bottom cage gaskets (key 11, figure 18, 19, or 20), place the cage into the valve body. Be sure the cage lugs are engaged in the corresponding recesses of the seat ring retainer. Turn the cage clockwise until the lugs contact the seat ring retainer. Install the plug, then slide the bonnet over the stem and onto the studs (key 13, figure 18, 19, or 20).

---

**Note**

The prelubricated hex nuts (key 14, figure 18, 19, or 20) referred to in step 12 can be identified by a black film coating on the nut threads.

The proper bolting procedures in step 12 include--but are not limited to--ensuring that the bonnet stud threads are clean, Belleville washers (if present) are installed in the correct orientation, and that the hex nuts are evenly tightened to the specified torque values.

---

**CAUTION**

**Failure to comply with good bonnet-to-body bolting practices and the torque values shown in table 8 may result in cage crushing, cage diameter reduction, and/or bonnet deformation. Cheater bars or slug wrenches should not be used for this procedure.**

**Hot torquing is not recommended.**

---

**Note**

Stud(s) and nut(s) should be installed such that the manufacturer's trademark and material grade marking is visible, allowing easy comparison to the materials selected and documented in the Emerson/Fisher serial card provided with this product.

---

**⚠ WARNING**

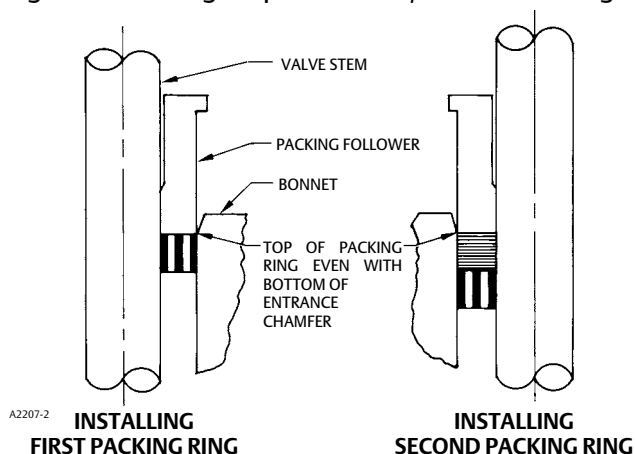
**Personal injury or damage to equipment could occur if improper stud and nut materials or parts are used. Do not operate or assemble this product with stud(s) and nut(s) that are not approved by Emerson/Fisher engineering and/or listed on the serial card provided with this product. Use of unapproved materials and parts could lead to stresses exceeding the design or code limits intended for this particular service. Install studs with the material grade and manufacturer's identification mark visible. Contact your [Emerson sales office](#) or Local Business Partner immediately if a discrepancy between actual parts and approved parts is suspected.**

---

12. Lubricate the stud threads and the faces of the hex nuts (key 14, figure 18, 19, or 20) with anti-seize lubricant (not necessary if new factory prelubricated hex nuts are used). Replace the flat washers (key 29, figure 18, 19, 17, or 20) if present. If the valve assembly includes Belleville washers (key 33, figure 17) install these onto the studs (key 14, figure 17) with the concave side facing towards the valve body. Replace the hex nuts but do not tighten them. Torque the nuts in a crisscross pattern to no more than one fourth of the nominal torque value specified in table 8.

When all nuts are tightened to that torque value, increase the torque by one fourth of the specified nominal torque and repeat the crisscross pattern. Repeat this procedure until all nuts are tightened to the specified nominal value. Apply the final torque value again and, if any nut still turns, tighten every nut again.

Figure 5. Installing Graphite Ribbon/Filament Packing Rings One at a Time



#### Note

If graphite ribbon/filament packing rings are used, special procedures must be observed to prevent entrapping air between the rings. Add the rings one at a time without forcing them below the chamfer of the packing box entrance chamber. As each successive ring is added, the stack should not be pushed down more than the thickness of the added ring (figure 5).

13. Install new packing and the metal packing box parts according to the appropriate arrangement in figure 4. If desired, packing parts may be pre-lubricated with a silicon base grease for easier installation. Slip a smooth-edged pipe over the valve stem, and gently tamp each soft packing part into the packing box, being sure that air is not trapped between adjacent soft parts. For a valve with extension bonnet, also install the baffle and retaining rings (keys 2 and 35).

14. Slide the packing follower, wiper, and packing flange into position. Lubricate the packing flange studs (key 4) and the faces of the packing flange nuts (key 5). Replace the packing flange nuts.

For spring-loaded PTFE V-ring packing, tighten the packing flange nuts until the shoulder on the packing follower (key 13) contacts the bonnet.

For other packing types, tighten the packing flange nuts to the maximum recommended torque shown in table 7. Then, loosen the packing flange nuts, and retighten them to the recommended minimum torque shown in table 7.

For ENVIRO-SEAL or HIGH-SEAL live-loaded packing, refer to the note at the beginning of the Maintenance section.

15. Mount the actuator on the valve body assembly, and reconnect the actuator and valve plug stems according to the procedures in the appropriate actuator instruction manual.

## Trim Removal

For C-seal construction, see the appropriate C-seal sections in this instruction manual.

Trim removal and replacement requires the use of a seat ring retainer tool (key 25). If specifically ordered, a tool is supplied with a valve; but, the tool can also be ordered separately by referencing the tool part number in the Parts List. If desired, a tool can also be machined for a valve of specific size and valve class using the dimensions shown in figure 9. Machine the tool from a material listed in figure 9 or from a material with a yield strength of at least 827 MPa (120,000 psi). Using a tool of lower strength material may result in damage to the seat ring retainer or valve body threads.

Key numbers referenced in this procedure are shown in figure 18 for the EHD valve, figure 19 for the EHS valve, and figure 20 for the EHT valve except where indicated.

1. Remove the actuator and bonnet by following steps 1 through 4 of the Replacing Packing procedure. Observe all warnings and cautions.
2. Lift the valve stem and attached valve plug out of the valve body. If the valve plug is to be reused, tape or otherwise protect the valve plug stem and the valve plug seating surface to prevent scratches.
3. Lift out the cage (key 2) and the top and bottom cage gaskets (key 11). For a valve with Cavitrol III two-or three-stage cage, also remove the O-ring (key 26, figure 21) that fits between the cage and the seat ring (key 6).

### Constructions other than TSO trim

1. Use the seat ring retainer tool (figure 9) to remove the seat ring retainer (key 7) as follows:
  - a. Insert the tool into the valve body. Be certain the tool lugs are engaged in the corresponding recesses in the retainer.
  - b. Use a power torque wrench or driver having torque capabilities equal to or greater than those shown in table 9. Connect the torque wrench to an extension if necessary. The tool or extension must snugly fit the square hole in the seat ring retainer tool. Refer to figure 9 for square hole sizes.
  - c. Insert the tool or extension into the square hole in the seat ring retainer tool.
  - d. Use the bonnet studs (key 13) to prevent a power torque wrench from rotating.

### CAUTION

**Hold the torque wrench or driver at right angles to the seat ring retainer when applying torque. Tilting the tool or extension while applying torque may cause the lugs on the seat ring retainer tool to suddenly disengage from the recesses in the retainer, damaging the retainer and seat ring.**

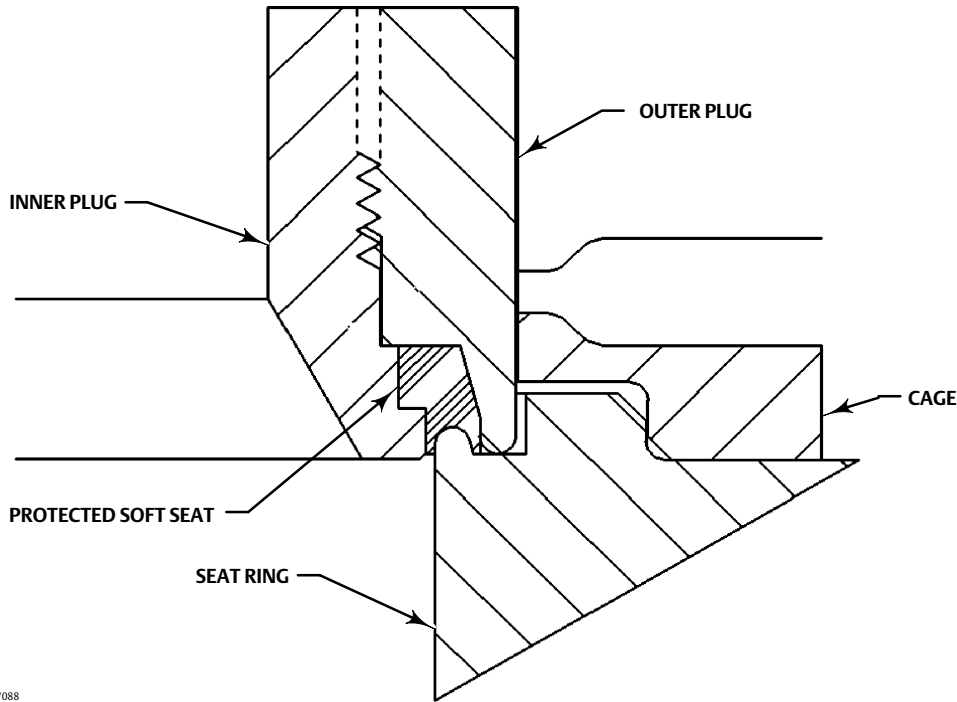
- e. Unscrew and remove the seat ring retainer.
2. Remove the seat ring (key 6) and the seat ring gasket or O-ring (key 12).
  3. Refer to the Valve Plug Maintenance procedure or to the Lapping Seats procedure.

### TSO Trim

Refer to figure 7.

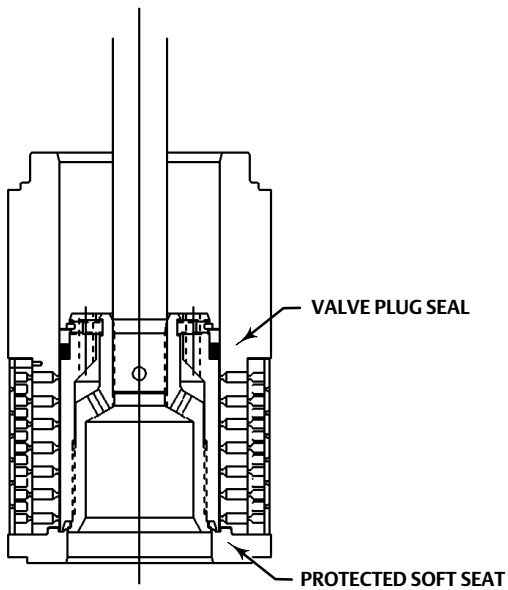
1. Remove the retainer, backup ring, anti-extrusion rings, and piston ring.
2. Remove the set screws that lock the outer plug to the inner plug.
3. Using a strap wrench or similar tool, unscrew the outer plug from the inner plug. Do not damage the outer plug guide surfaces.
4. Remove the protected soft seat seal (see figure 5).
5. Inspect the parts for damage and replace if needed.
6. Refer to the Valve Plug Maintenance procedure or to the Lapping Seats procedure.

Figure 6. Detail of Protected Soft Seat



A7088

Figure 7. Typical Balanced TSO Trim



A7096

## Valve Plug Maintenance

Key numbers used in this procedure are shown in figure 18 for the EHD valve, in figure 19 for the EHS valve, and in figure 20 for the EHT valve.

1. With the valve plug (key 3) removed according to the Trim Removal procedure, proceed as appropriate:  
For the EHD valve, the piston rings (key 8) are each in two sections; remove the sections from the grooves in the valve plug.  
For the EHS valve, proceed to step 2.  
For the EHT valve, work the retaining ring (key 10) off the valve plug with a screwdriver. Carefully slide the backup ring and seal ring (keys 9 and 8) off the valve plug. For an NPS 6 valve with a level D Whisper Trim III cage, also remove the piston ring (key 30) from the grooves in the valve plug.
2. To replace the valve plug stem (key 4), drive out the pin (key 5), and unscrew the stem from the valve plug.

## CAUTION

**Never reuse an old stem with a new valve plug or reinstall a valve stem after it has been removed. Using an old stem with a new plug requires drilling a new pin hole in the stem. This weakens the stem and may cause the stem to fail in service. If a new valve plug is required, always order a valve plug, stem, and pin as an assembly. Specify the correct part number of each of the three parts, but state that the parts are being ordered as an assembly.**

**A used valve plug may be reused with a new stem. An exception is the Cavitrol III plug/stem assembly which must be ordered and replaced as a unit.**

3. Thread the new stem into the valve plug and tighten it to the appropriate torque value given in table 10. Using the valve plug pin hole as a guide, drill the pin hole through the stem. Refer to table 10 for drill sizes.
4. Drive in the pin to lock the assembly.
5. If it is necessary to lap the seating surfaces, complete the Lapping Seats procedure before installing the EHD piston rings or the EHT seal ring. The Trim Replacement procedure provides piston ring and seal ring installation instructions and valve reassembly instructions.

## Lapping Seats

Key numbers referenced in this procedure are shown in figure 18 for the EHD valve, in figure 19 for the EHS valve, and in figure 20 for the EHT valve unless otherwise indicated.

Seating surfaces of the valve plug (key 3) and the seat ring (key 6) can be lapped for improved shutoff. Use a good quality lapping compound with a mixture that contains 280 to 600 grit. Apply the compound to the bottom of the valve plug. Use the following procedure to lap the seating surfaces.

1. Install the following parts according to the instructions presented in the Trim Replacement procedure: seat ring gasket or O-ring (key 12), seat ring (key 6), seat ring retainer (key 7), cage (key 2), cage gaskets (key 11), and if used, the O-ring (key 26, figure 21).
2. Proceed as appropriate:  
For an EHD or EHT valve, install the valve plug and stem assembly (keys 3 and 4)—without piston rings or seal ring (keys 8 and 30)—into the cage.  
For an EHS valve, install the valve plug and stem assembly (keys 3 and 4) into the cage.
3. Install the bonnet (key 1, figure 16) over the valve stem, and secure the bonnet with four of the hex nuts (key 14).
4. Attach a handle, such as a piece of strap iron secured by stem locknuts, to the valve stem. Rotate the handle alternately in each direction to lap the seats.

## Note

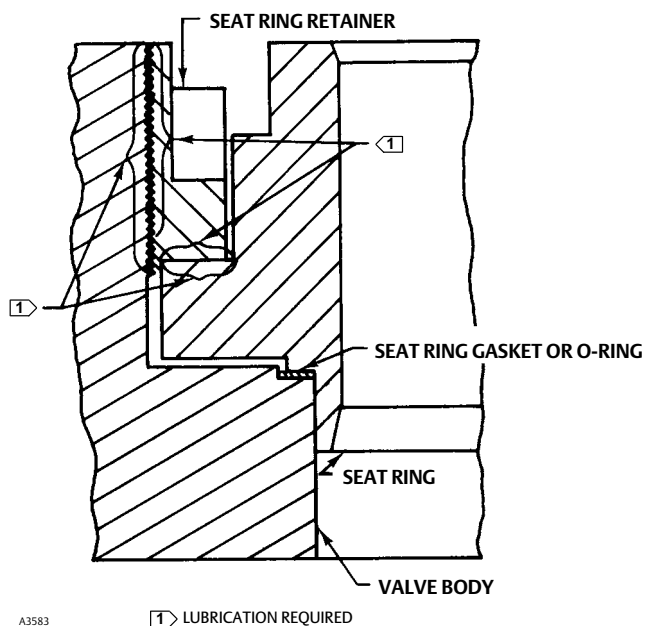
To preserve the effects of lapping, do not change either the position of the seat ring in the valve body cavity or the position of the cage on the seat ring after lapping the seating surfaces. If possible, clean the parts without disturbing their positions. If the parts must be removed for cleaning, return them to the original positions.

5. After lapping, again disassemble as necessary, clean the seating surfaces, reassemble, and test for shutoff. Repeat the lapping procedure if necessary.

## Trim Replacement

After all trim maintenance has been completed, reassemble the valve by following the numbered steps below. Be certain that all gasketed surfaces have been well cleaned. Key numbers referenced in this procedure are shown in figure 18 for the EHD valve, in figure 19 for the EHS valve, and in figure 20 for the EHT valve.

Figure 8. Trim Surfaces Requiring Lubrication



### CAUTION

Thoroughly clean the seat ring (key 6), seat ring retainer (key 7), and the retainer threads in the valve body with a good-quality degreaser. Also clean all cage gasket surfaces. All residual gasket material must be removed from the cage gasket surfaces and, in gasketed seat ring constructions, from the serrated valve body and seat ring gasket surfaces. If the serrations are scored or damaged during this process, smooth them by hand sanding with 360 grit paper using long, sweeping strokes. Failure to remove all residual gasket material and/or burrs from the seat ring, cage, and valve body gasket surfaces will result in leakage.

Thoroughly lubricate the surfaces indicated in figure 8 with the appropriate lubricant shown in table 11. Be certain to lubricate the mating surfaces of both parts involved (i.e., lubricate the threads on the seat ring retainer and the threads in the valve body; lubricate the mating surfaces of the seat ring retainer and seat ring).

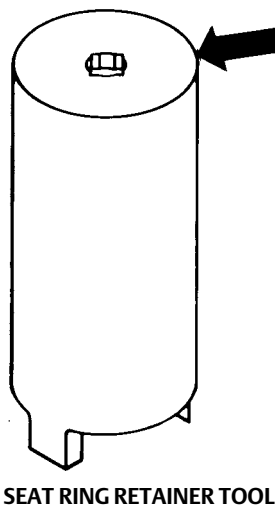
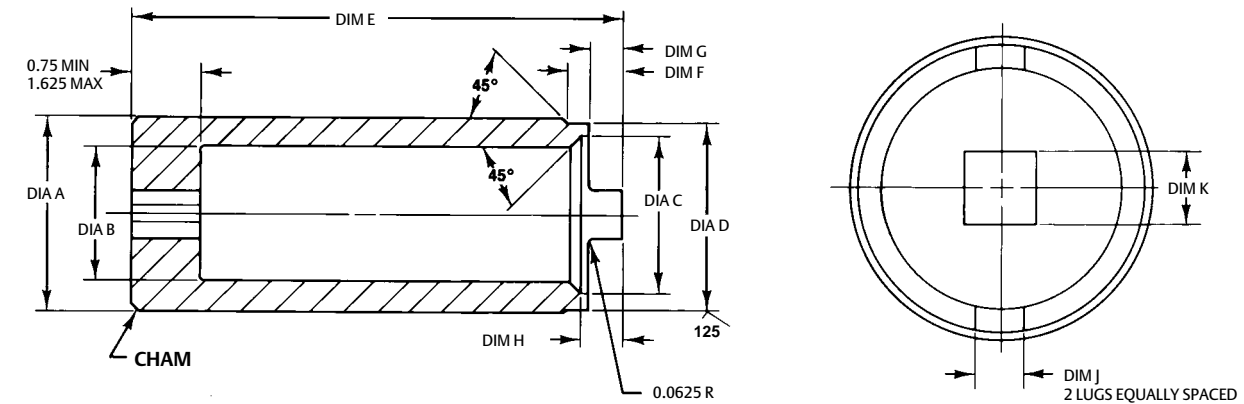
Failure to lubricate as described may cause galling and improper gasket or O-ring (key 12) loading that may result in leakage.



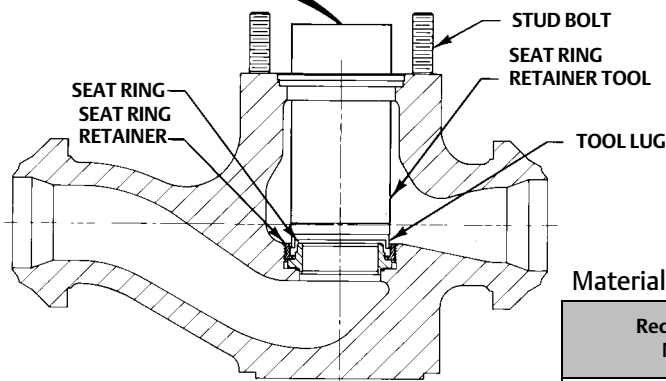
VALVE SIZE, NPS/RATING	VALVE RATING	TOOL DIMENSIONS																			
		mm										Inches									
		A	B	C	D <sup>(1)</sup>	E	F	G	H	J <sup>(1)</sup>	K	A	B	C	D <sup>(1)</sup>	E	F	G	H	J <sup>(1)</sup>	K
1-1/2x1	CL1500	57.2	31.8	41.1	<u>54.4</u> 51.9	120.7	11.2	7.9	11.2	<u>12.4</u> 12.2	19.1	2.25	1.25	1.62	<u>2.140</u> 2.120	4.75	0.44	0.31	0.44	<u>0.49</u> 0.48	0.75
	CL2500	50.8	31.8	34.1	<u>46.4</u> 45.9	111.3	11.2	7.9	11.2	<u>12.4</u> 12.2	19.1	2.00	1.25	1.34	<u>1.827</u> 1.807	4.38	0.44	0.31	0.44	<u>0.49</u> 0.48	0.75
2x1	CL1500	57.2	31.8	41.1	<u>54.4</u> 51.9	120.7	11.2	7.9	11.2	<u>12.4</u> 12.2	19.1	2.25	1.25	1.62	<u>2.140</u> 2.120	4.75	0.44	0.31	0.44	<u>0.49</u> 0.48	0.75
	CL2500	50.8	31.8	34.1	<u>46.4</u> 45.9	111.3	11.2	7.9	11.2	<u>12.4</u> 12.2	19.1	2.00	1.25	1.34	<u>1.827</u> 1.807	4.38	0.44	0.31	0.44	<u>0.49</u> 0.48	0.75
3x2	CL1500	79.2	53.8	63.5	<u>76.6</u> 76.1	157.2	12.7	9.7	12.7	<u>12.4</u> 12.2	19.1	3.12	2.12	2.50	<u>3.015</u> 2.995	6.19	0.50	0.38	0.50	<u>0.49</u> 0.48	0.75
	CL2500	69.9	50.8	53.0	<u>67.1</u> 66.5	150.9	12.7	9.7	12.7	<u>12.4</u> 12.2	19.1	2.75	2.00	2.12	<u>2.640</u> 2.620	5.94	0.50	0.38	0.50	<u>0.49</u> 0.48	0.75
3, 4x3	CL2500	90.5	65.0	74.6	<u>86.1</u> 85.6	185.7	12.7	9.7	12.7	<u>18.8</u> 18.5	25.4	3.56	2.36	2.94	<u>3.390</u> 3.370	7.31	0.50	0.38	0.50	<u>0.74</u> 0.73	1.00
4, 6x4	CL2500	117.3	88.9	91.9	<u>108.3</u> 107.8	195.3	14.2	10.4	14.2	<u>25.1</u> 24.9	25.4	4.62	3.50	3.62	<u>4.265</u> 4.245	7.69	0.56	0.41	0.56	<u>0.99</u> 0.98	1.00
6, 8x6	CL2500	177.8	130.0	134.9	<u>156.0</u> 155.4	254.0	14.2	10.4	14.2	<u>25.1</u> 24.9	38.1	7.00	5.12	5.31	<u>6.140</u> 6.120	10.00	0.56	0.41	0.56	<u>0.99</u> 0.96	1.50

1. D and J dimensions list maximum and minimum values.

Figure 9. Information for Machining and Use of Seat Ring Retainer Tool



3MC2169-E  
35A1086-A  
25A5130-A  
B1465-2



**TOOL INSTALLATION**

**Materials for Machining Tool**

Recommended Materials	Minimum Rockwell Hardness
416 stainless steel	28
17-4PH stainless steel	36
4100 Series heat-treated steel	31

Table 9. Recommended Torque for Installing Seat Ring Retainer

VALVE SIZE, NPS	VALVE BODY RATING	TORQUE							
		For All Valves with Gasketed Seat Ring Construction Except Those with Cavitrol III Cage		For All Valves with O-Ring Seat Ring Construction <sup>(1)</sup> or for Sour Gas Service		For Valve with 2-Stage Cavitrol III Cage and Gasketed Seat Ring Construction		For Valve with 3-Stage Cavitrol III Cage and Gasketed Seat Ring Construction	
		N•m	Lbf•Ft	N•m	Lbf•Ft	N•m	Lbf•Ft	N•m	Lbf•Ft
1, 1-1/2x1, 2x1	CL1500	509	375	68	50	339	250	---	---
	CL2500	373	275	68	50	203	150	---	---
2, 3x2	CL1500	1187	875	136	100	881	650	678	500
	CL2500	848	625	102	75	542	400	407	300
3, 4x3	CL1500	2203	1625	271	200	1491	1100	1356	1000
	CL2500	1593	1175	203	150	949	700	678	500
4, 6x4	CL1500	3118	2300	373	275	2712	2000	2373	1750
	CL2500	2373	1750	271	200	2373	1750	1695	1250
6, 8x6	CL1500	6780	5000	780	575	6101	4500	5423	4000
	CL2500	5017	3700	576	425	4745	3500	4745	3500

1. Includes valves with Cavitrol III trim.

Table 10. Valve Stem Connection Torque and Drill Size for Pin Hole

VALVE SIZE, NPS	VALVE STEM DIAMETER		VALVE BODY RATING	VALVE	VALVE STEM CONNECTION TORQUE (MINIMUM - MAXIMUM)		DRILL SIZE FOR PIN	
	mm	Inches			N•m	Lbf•Ft	Inches	
	1, 1-1/2x1, 2x1	12.7			1/2	CL1500, CL2500	EHS	81 - 115
19.1		3/4	CL1500	EHS	237 - 339	175 - 250	3/16	
2, 3x2	12.7	1/2	CL1500, CL2500	EHD, EHS, EHT	81 - 115	60 - 85	1/8	
	19.1	3/4	CL1500, CL2500	EHS	237 - 339	175 - 250	3/16	
				EHD, EHT	237 - 339	175 - 250	1/8	
	25.4	1	CL1500, CL2500	EHS	420 - 481	310 - 355	1/4	
3, 4x3	12.7	1/2	CL1500, CL2500	EHD, EHS, EHT	81 - 115	60 - 85	1/8	
	19.1	3/4	CL1500, CL2500	EHD, EHS, EHT	237 - 339	175 - 250	3/16	
				EHS	420 - 481	310 - 355	1/4	
	25.4	1	CL1500, CL2500	CL1500	EHD, EHT	420 - 481	310 - 355	1/4
				CL2500	EHD, EHT	420 - 481	310 - 355	3/16
4, 6x4	19.1	3/4	CL1500, CL2500	EHD, EHS, EHT	237 - 339	175 - 250	3/16	
	25.4	1	CL1500, CL2500	EHD, EHS, EHT	420 - 481	310 - 355	1/4	
6, 8x6	19.1	3/4	CL1500, CL2500	EHD, EHS, EHT	237 - 339	175 - 250	3/16	
	25.4	1	CL1500, CL2500	EHD, EHS, EHT	420 - 481	310 - 355	1/4	
				EHD, EHS, EHT	827 - 908	610 - 670	1/4	
	50.8	2	CL1500, CL2500	EHD, EHT	Contact factory for torque values and installation procedure		3/8	

Table 11. Seat Ring and Seat Ring Retainer Lubricants

VALVE BODY MATERIAL	SEAT RING MATERIAL	LUBRICANT
WCC, WC9, C5, or LCC steel	S41600 (416 stainless steel)	Lithium grease, dry film lubricant, or anti-seize lubricant
	R30006 (Alloy 6)	Anti-seize lubricant
CF8M (316 stainless steel)	R30006	Dry film lubricant or anti-seize lubricant

1. For gasketed seat ring constructions, install the seat ring gasket (key 12) into the valve body. For O-ring seat ring constructions, install the O-ring (key 12) into the groove on the underside of the seat ring (key 6). Install the seat ring (key 6). Screw in the seat ring retainer (key 7). Use the seat ring retainer tool (figure 9) to tighten the seat ring retainer as follows:

- a. Insert the tool into the valve body. Be certain the tool lugs are engaged in the corresponding recesses in the retainer.

- b. Use a power torque wrench or driver having torque capabilities equal to or greater than those shown in table 9. Connect the torque tool to an extension if necessary. The tool or extension must snugly fit the square hole in the seat ring retainer tool. Refer to figure 9 for square hole sizes.
- c. Insert the tool or extension into the square hole in the seat ring retainer tool.
- d. Use the stud bolts (key 13) to prevent a power torque wrench from rotating.

## CAUTION

**Hold the torque wrench at right angles to the seat ring retainer when applying torque. Tilting the tool and extension while applying torque may cause the lugs on the seat ring retainer tool to suddenly disengage from the recesses in the retainer, damaging the retainer and seat ring.**

- e. Tighten the seat ring retainer to the torque shown in table 9.

### Note

Some cages have one large window and several small windows. In step 2, install a cage that has different size windows so that the largest window faces toward the process outlet for a flow-down and toward the process inlet for a flow-up valve. Though it may not be possible to align the large window directly opposite the inlet or outlet, orient the window in the appropriate direction as much as possible. Incorrect orientation of cage windows causes a reduction of capacity.

## 2. Proceed as appropriate:

For a valve with a Cavitol III cage, slide the O-ring (key 26, figure 21) over the seat ring (key 6) and against the shoulder in the outer diameter of the seat ring. Install the lower gasket (key 11) between the valve body and cage (key 2), and install the cage. Be certain the lugs on the bottom of the cage engage the corresponding slots in the seat ring retainer.

For all other valves, install the lower gasket (key 11) between the valve body and cage (key 2), and install the cage. Be certain the lugs on the bottom of the cage engage the corresponding slots in the seat ring retainer.

### Note

Rotate the cage clockwise by hand as much as possible once the cage lugs engage the slots in the seat ring retainer. Failure to do so may result in leakage at the seat ring to valve body seal.

## Constructions other than TSO trim

### 1. To install the piston rings and seal rings (keys 8 and 30), proceed as appropriate:

For an EHD valve (figure 18), if it is necessary to install new piston rings, the replacement piston rings will arrive in one piece. Use a vise with smooth or taped jaws to break a replacement piston ring into halves. Place the new ring in the vise so that the jaws compress the ring into an oval. Compress the ring slowly until the ring snaps on both sides. If one side snaps first, do not try to tear or cut the other side. Instead, keep compressing until the other side snaps. The piston ring can also be fractured by scoring and snapping over a hard surface such as a table edge. Sawing or cutting is not recommended.

Remove any protective tape or covering from the valve plug and stem assembly, and set it on a protective surface. Then, place the piston ring in the piston ring groove with the fractured ends matched.

For an EHT valve (figure 20), install the seal ring (key 8) onto the valve plug (key 3). Install the ring with the open side facing the seat ring end of the valve plug for flow-down applications (view A of figure 20) or with the open side facing the valve plug stem end of the valve plug for flow-up applications. Slide the backup ring (key 9) onto the valve plug. Secure with the retaining ring (key 10). For an NPS 6 valve with a level D Whisper Trim III cage, reinstall the piston ring (key 30) following the instructions given in the paragraph immediately preceding.

2. Install the valve plug into the cage.

## TSO Trim

Refer to figure 7.

1. Thread the outer plug onto the inner plug until the parts seat metal to metal, using a strap wrench or similar tool that will not damage the outer plug guide surfaces.
2. Mark the top of the inner plug and outer plug with alignment marks in the assembled position.
3. Disassemble the outer plug from the inner plug and install the seal over the inner plug, so that the seal rests below the threaded area.
4. Thread the outer plug onto the inner plug and tighten with a strap wrench or similar tool until the alignment marks line up. This will ensure that the plug parts are metal to metal and the seal is compressed properly. Do not damage the outer plug guide surfaces.
5. Install set screws centering the inner plug in the outer plug and torque to 11 N•m (8 lbf•ft).
6. Assemble the piston ring, anti-extrusion rings, backup ring, and retainer.

## All Constructions

1. Install the top cage gasket (key 11) on the cage.
2. Install the bonnet over the valve stem and onto the valve body.

---

### Note

The prelubricated hex nuts (key 14, figure 18, 19, or 20) referred to in step 3 can be identified by a black film coating on the nut threads.

The proper bolting procedures in step 3 include--but are not limited to--ensuring that the bonnet stud threads are clean, Belleville washers (if present) are installed in the correct orientation, and that the hex nuts are evenly tightened to the specified torque values.

---

## CAUTION

**Failure to comply with good bonnet-to-body bolting practices and the torque values shown in table 8 may result in cage crushing, cage diameter reduction, and/or bonnet deformation. Cheater bars or slug wrenches should not be used for this procedure.**

**Hot torquing is not recommended.**

---

### Note

Stud(s) and nut(s) should be installed such that the manufacturer's trademark and material grade marking is visible, allowing easy comparison to the materials selected and documented in the Emerson/Fisher serial card provided with this product.

---

**⚠ WARNING**

Personal injury or damage to equipment could occur if improper stud and nut materials or parts are used. Do not operate or assemble this product with stud(s) and nut(s) that are not approved by Emerson/Fisher engineering and/or listed on the serial card provided with this product. Use of unapproved materials and parts could lead to stresses exceeding the design or code limits intended for this particular service. Install studs with the material grade and manufacturer's identification mark visible. Contact your [Emerson sales office](#) or Local Business Partner immediately if a discrepancy between actual parts and approved parts is suspected.

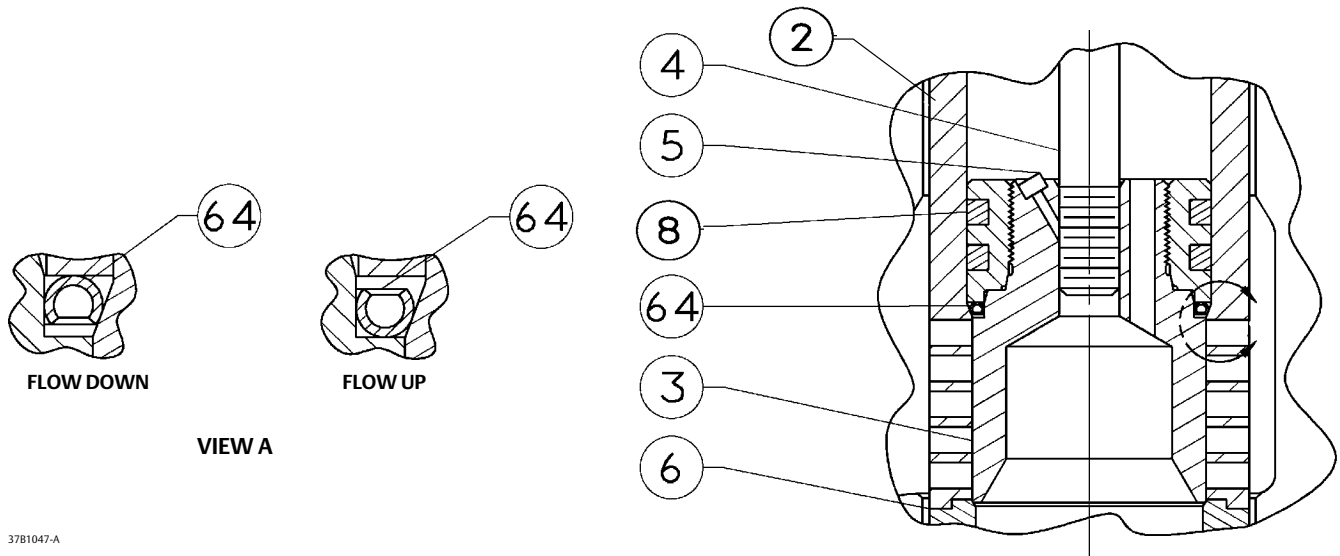
3. Lubricate the stud threads and the faces of the hex nuts (key 14, figure 18, 19, or 20) with anti-seize lubricant (not necessary if new factory prelubricated hex nuts are used). Replace the flat washers (key 29, figure 18, 19, 17, or 20) if present. If the valve assembly includes Belleville washers (key 33, figure 17) install these onto the studs (key 14, figure 17) with the concave side facing towards the valve body. Replace the hex nuts but do not tighten them. Torque the nuts in a crisscross pattern to no more than one fourth of the nominal torque value specified in table 8. When all nuts are tightened to that torque value, increase the torque by one fourth of the specified nominal torque and repeat the crisscross pattern. Repeat this procedure until all nuts are tightened to the specified nominal value. Apply the final torque value again and, if any nut still turns, tighten every nut again.
4. Install new packing and packing box parts per steps 13 and 14 of the Replacing Packing procedure. Be certain to observe the note given prior to step 13 of that procedure.
5. Mount the actuator by following the procedures in the actuator instruction manual. Check for packing leakage as the valve is being put into service. Retorque the packing flange nuts as required (see table 7).

## Retrofit: Installing C-seal Trim

**Note**

Additional actuator thrust is required for a valve with C-seal trim. When installing C-seal trim in an existing valve, contact your [Emerson sales office](#) or Local Business Partner for assistance in determining new actuator thrust requirements.

Figure 10. Fisher EHD with C-seal Trim



3781047-A

Assemble the new valve plug/retainer assembly (with C-seal plug seal) using the following instructions:

## CAUTION

**To avoid leakage when the valve is returned to service, use appropriate methods and materials to protect all sealing surfaces of the new trim parts while assembling the individual parts and during installation in the valve body.**

1. Apply a suitable high-temperature lubricant to the inside diameter of the C-seal plug seal. Also, lubricate the outside diameter of the valve plug where the C-seal plug seal must be pressed into the proper sealing position (figure 10).
2. Orient the C-seal plug seal for correct sealing action based on the process fluid flow direction through the valve.
  - The open interior of the C-seal plug seal must face up in a valve with flow-up construction (figure 10).
  - The open interior of the C-seal plug seal must face down in a valve with flow-down construction (figure 10).

### Note

An installation tool must be used to properly position the C-seal plug seal on the valve plug. A tool is available as a spare part from your [Emerson sales office](#) or Local Business Partner or a tool could be manufactured following the dimensions given in figure 11.

3. Place the C-seal plug seal over the top of the valve plug and press the C-seal plug seal onto the plug using the C-seal installation tool. Carefully press the C-seal plug seal onto the plug until the installation tool contacts the horizontal reference surface of the valve plug (figure 12).
4. Apply a suitable high-temperature lubricant to the threads on the plug. Then, place the C-seal retainer onto the plug and tighten the retainer using an appropriate tool such as a strap wrench.
5. Using an appropriate tool such as a center punch, stake the threads on top of the plug in one place (figure 13) to secure the C-seal retainer.
6. Install the new plug/retainer assembly with C-seal plug seal on the new stem following the appropriate instructions in the Trim Replacement section of this manual.
7. Install piston rings by following instructions in the Trim Replacement section of this manual.
8. Remove the existing valve actuator and bonnet following the appropriate instructions in the Replacing Packing section of this manual.

## CAUTION

**Do not remove the existing valve stem from the valve plug unless you are planning to replace the valve stem.**

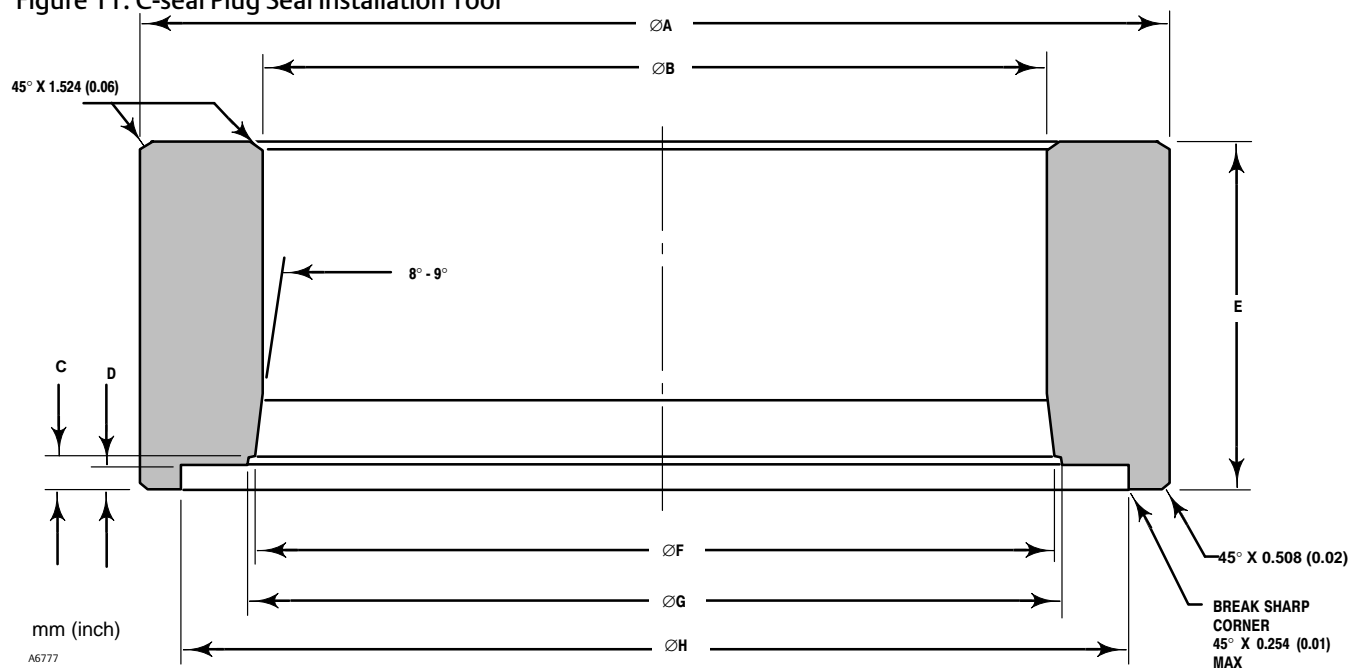
**Never reuse an old valve stem with a new plug or reinstall a valve stem after it has been removed. Replacing a valve stem requires drilling a new pin hole in the stem. This drilling weakens the stem and may cause failure in service.**

**However, a used valve plug may be reused with a new valve stem. An exception is the Cavitrol III plug/stem assembly which must be ordered and replaced as a unit.**

9. Remove the existing valve stem and plug, cage, and seat ring from the valve body following the appropriate instructions in the Trim Removal section of this manual.
10. Replace all gaskets according to appropriate instructions in the Trim Replacement section of this manual.

FOR VALVE PLUGS FITTING PORT SIZE (Inches)	DIMENSIONS, mm (See Drawing Below)								Part Number (To Order A Tool)
	A	B	C	D	E	F	G	H	
2.875	82.55	52.324 - 52.578	4.978 - 5.029	3.708 - 3.759	41.148	52.680 - 52.781	55.118 - 55.626	70.891 - 71.044	24B9816X012
3.4375	101.6	58.674 - 58.928	4.978 - 5.029	3.708 - 3.759	50.8	61.011 - 61.112	63.449 - 63.957	85.166 - 85.319	24B5612X012
3.625	104.394	65.024 - 65.278	4.978 - 5.029	3.708 - 3.759	50.8	68.936 - 69.037	71.374 - 71.882	89.941 - 90.094	24B3630X012
4.375	125.984	83.439 - 83.693	4.978 - 5.029	3.708 - 3.759	50.8	87.351 - 87.452	89.789 - 90.297	108.991 - 109.144	24B3635X012
5.375	142.748	100.076 - 100.33	4.978 - 5.029	3.708 - 3.759	45.974	103.835 - 103.937	106.274 - 106.782	128.219 - 128.372	23B9193X012
7	184.15	141.376 - 141.630	4.978 - 5.029	3.708 - 3.759	60.198	145.136 - 145.237	147.574 - 148.082	169.520 - 169.672	23B9180X012
8	209.55	166.776 - 167.030	4.978 - 5.029	3.708 - 3.759	55.88	170.536 - 170.637	172.974 - 173.482	194.920 - 195.072	24B9856X012
FOR VALVE PLUGS FITTING PORT SIZE (Inches)	Dimensions, Inches (See Drawing Below)								Part Number (To Order A Tool)
	A	B	C	D	E	F	G	H	
2.875	3.25	2.060 - 2.070	0.196 - 0.198	0.146 - 0.148	1.62	2.074 - 2.078	2.170 - 2.190	2.791 - 2.797	24B9816X012
3.4375	4.00	2.310 - 2.320	0.196 - 0.198	0.146 - 0.148	2.00	2.402 - 2.406	2.498 - 2.518	3.353 - 3.359	24B5612X012
3.625	4.11	2.560 - 2.570	0.196 - 0.198	0.146 - 0.148	2.00	2.714 - 2.718	2.810 - 2.830	3.541 - 3.547	24B3630X012
4.375	4.96	3.285 - 3.295	0.196 - 0.198	0.146 - 0.148	2.00	3.439 - 3.443	3.535 - 3.555	4.291 - 4.297	24B3635X012
5.375	5.62	3.940 - 3.950	0.196 - 0.198	0.146 - 0.148	1.81	4.088 - 4.092	4.184 - 4.204	5.048 - 5.054	23B9193X012
7	7.25	5.566 - 5.576	0.196 - 0.198	0.146 - 0.148	2.37	5.714 - 5.718	5.810 - 5.830	6.674 - 6.680	23B9180X012
8	8.25	6.566 - 6.576	0.196 - 0.198	0.146 - 0.148	2.20	6.714 - 6.718	6.810 - 6.830	7.674 - 7.680	24B9856X012

Figure 11. C-seal Plug Seal Installation Tool



11. Install the new seat ring, cage, valve plug/retainer assembly, and stem into the valve body and completely reassemble the valve package following the appropriate instructions in the Trim Replacement section of this manual.

## CAUTION

To avoid excessive leakage and seat erosion, the valve plug must be initially seated with sufficient force to overcome the resistance of the C-seal plug seal and contact the seat ring. You can correctly seat the valve plug by using the same force calculated for full load when sizing your actuator. With no pressure drop through the valve, this force will adequately drive the valve plug to the seat ring, thus giving the C-seal plug seal a predetermined permanent set. Once this is done, the plug/retainer assembly, the cage, and the seat ring become a matched set.

12. With full actuator force applied and the valve plug fully seated, align the actuator travel indicator scale with the lower end of valve travel. Refer to the appropriate actuator instruction manual for information on this procedure.

## Replacement of Installed C-seal Trim

### Trim Removal (C-seal Constructions)

1. Remove the valve actuator and bonnet following the appropriate instructions in the Replacing Packing section of this manual.

## CAUTION

To avoid leakage when the valve is returned to service, use appropriate methods and materials to protect all sealing surfaces of the trim parts during maintenance.

Use caution when removing piston ring(s) and C-seal plug seal to avoid scratching any sealing surface.

## CAUTION

Do not remove the valve stem from the plug/retainer assembly unless you are planning to replace the valve stem.

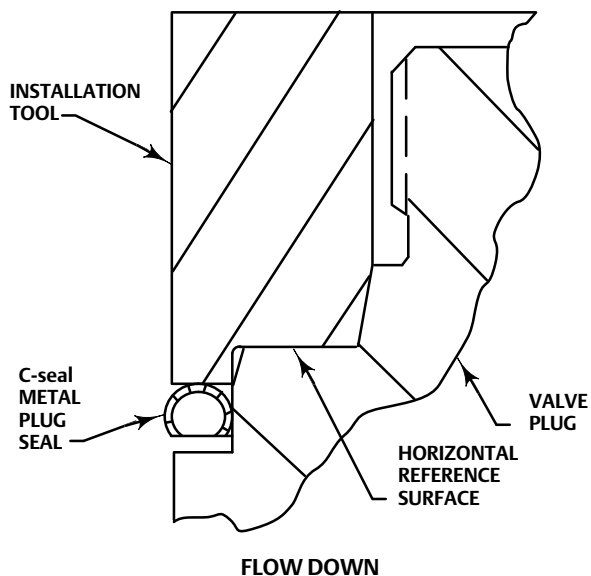
Never reuse an old valve stem with a new plug or reinstall a valve stem after it has been removed. Replacing a valve stem requires drilling a new pin hole in the stem. This drilling weakens the stem and may cause failure in service.

However, a used valve plug may be reused with a new valve stem. An exception is the Cavtrol III plug/stem assembly which must be ordered and replaced as a unit.

2. Remove the plug/retainer assembly (with C-seal plug seal), cage, and seat ring from the valve body following the appropriate instructions in the Trim Removal section of this manual.
3. Locate the staked thread on top of the valve plug (figure 13). The staked thread secures the retainer. Use a drill with a 1/8-inch bit to drill out the staked area of the thread. Drill approximately 1/8-inch into the metal to remove the staking.
4. Locate the break between sections of the piston ring(s). Using an appropriate tool such as a flat-blade screwdriver, carefully pry out the piston ring(s) from the groove(s) in the C-seal retainer.
5. After removing the piston ring(s), locate the 1/4-inch diameter hole in the groove. In a retainer with two piston ring grooves, the hole will be found in the upper groove.



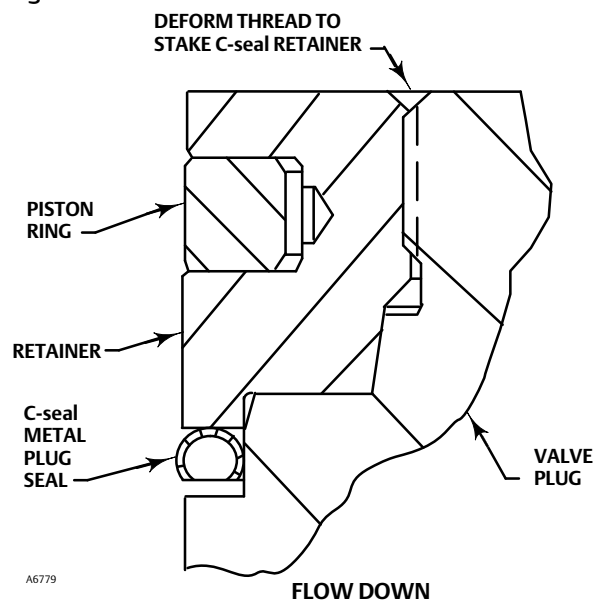
Figure 12. Installing the C-seal Plug Seal Using the Installation Tool



NOTE:  
PRESS INSTALLATION TOOL OVER VALVE PLUG UNTIL THE TOOL CONTACTS THE HORIZONTAL REFERENCE SURFACE OF THE VALVE PLUG.

A6778

Figure 13. Stake the Threads of the C-seal Retainer



A6779

6. Select an appropriate tool such as a punch and place the tip of the tool into the hole with the body of the tool held tangent to the outside diameter of the retainer. Strike the tool with a hammer to rotate the retainer and free it from the valve plug. Remove the retainer from the plug.
7. Use an appropriate tool such as a flat-blade screwdriver to pry the C-seal plug seal off the plug. Use caution to avoid scratches or other damage to the sealing surfaces where the C-seal plug seal makes contact with the valve plug (figure 14).
8. Inspect the lower seating surface where the valve plug contacts the seat ring for wear or damage which would prevent proper operation of the valve. Also, inspect the upper seating surface inside the cage where the C-seal plug

seal contacts the cage, and inspect the sealing surface where the C-seal plug seal makes contact with the plug (figure 14).

9. Replace or repair trim parts according to the following procedure for lapping metal seats, remachining metal seats, or other valve plug maintenance procedures as appropriate.

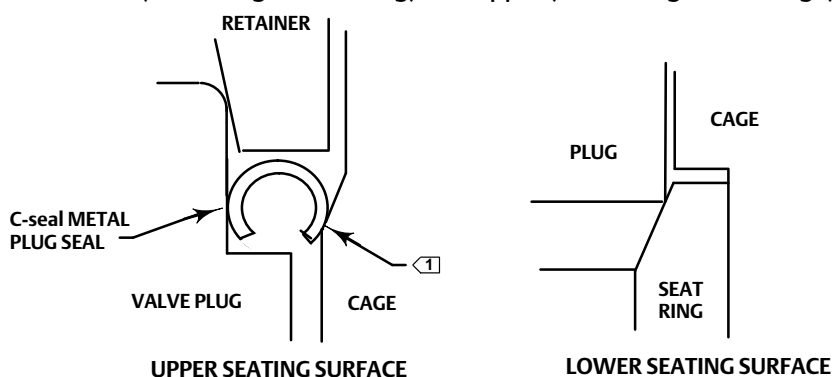
### Lapping Metal Seats (C-seal Constructions)

Before installing a new C-seal plug seal, lap the lower seating surface (valve plug to seat ring, figure 14) following appropriate procedures in the Lapping Seats section of this manual.

### Remachining Metal Seats (C-seal Constructions)

See figure 15. A valve plug with a C-seal metal plug seal features two seating surfaces. One seating surface is found where the valve plug contacts the seat ring. The second seating surface is found where the C-seal plug seal contacts the upper seating surface in the cage. If you machine the seats on the seat ring and/or plug, you must machine an equal dimension from the seating area in the cage.

Figure 14. Lower (Valve Plug to Seat Ring) and Upper (C-seal Plug Seal to Cage) Seating Surfaces



A6780

NOTE:

1 > UPPER SEATING SURFACE IS THE AREA OF CONTACT BETWEEN THE C-seal METAL PLUG SEAL AND THE CAGE.

## CAUTION

If metal is removed from the seat ring and plug and a corresponding amount is not removed from the cage seating area, the C-seal plug seal will be crushed as the valve closes and the C-seal retainer will strike the seating area of the cage, preventing the valve from closing.

### Trim Replacement (C-seal Constructions)

1. Apply a suitable high-temperature lubricant to the inside diameter of the C-seal plug seal. Also, lubricate the outside diameter of the valve plug where the C-seal plug seal must be pressed into the proper sealing position (figure 10).
2. Orient the C-seal plug seal for correct sealing action based on the process fluid flow direction through the valve.
  - The open interior of the C-seal plug seal must face up in a valve with flow-up construction (figure 10).
  - The open interior of the C-seal plug seal must face down in a valve with flow-down construction (figure 10).

#### Note

An installation tool must be used to properly position the C-seal plug seal on the valve plug. A tool is available as a spare part from your [Emerson sales office](#) or Local Business Partner or a tool could be manufactured following the dimensions given in figure 11.

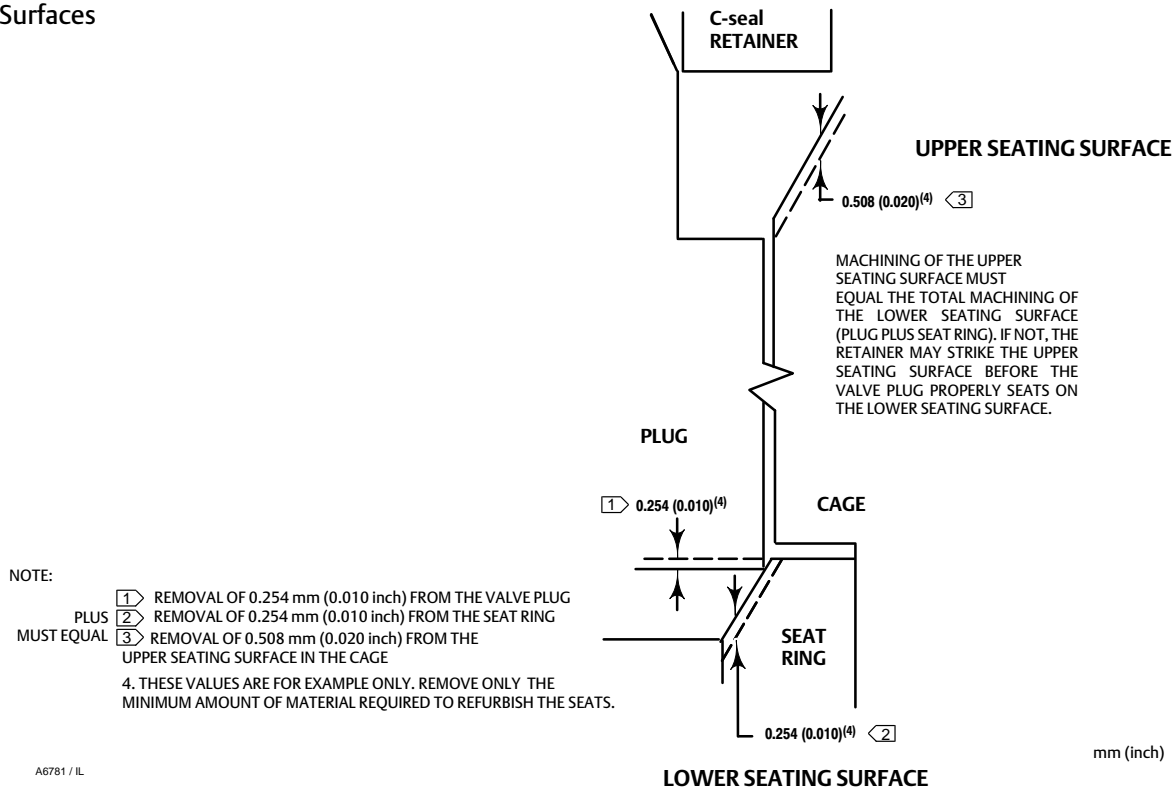
3. Place the C-seal plug seal over the top of the valve plug and press it onto the plug using the installation tool. Carefully press the C-seal plug seal onto the plug until the installation tool contacts the horizontal reference surface of the valve plug (figure 12).
4. Apply a suitable high-temperature lubricant to the threads on the plug. Then, place the C-seal retainer onto the plug and tighten the retainer using an appropriate tool such as a strap wrench.
5. Using an appropriate tool such as a center punch, stake the threads on top of the plug in one place (figure 13) to secure the C-seal retainer.
6. Replace the piston ring(s) following instructions in the Trim Replacement section of this manual.
7. Return the seat ring, cage, plug/retainer assembly, and stem to the valve body and completely reassemble the valve package following the appropriate instructions in the Trim Replacement section of this manual.

**CAUTION**

To avoid excessive leakage and seat erosion, the valve plug must be initially seated with sufficient force to overcome the resistance of the C-seal plug seal and contact the seat ring. You can correctly seat the valve plug by using the same force calculated for full load when sizing your actuator. With no pressure drop through the valve, this force will adequately drive the valve plug to the seat ring, thus giving the C-seal plug seal a predetermined permanent set. Once this is done, the plug/retainer assembly, the cage, and the seat ring become a matched set.

8. With full actuator force applied and the valve plug fully seated, align the actuator travel indicator scale with the lower end of valve travel. Refer to the appropriate actuator instruction manual for information on this procedure.

Figure 15. Example of Machining the Lower (Valve Plug to Seat Ring) and Upper (C-seal Plug Seal to Cage) Seating Surfaces



A6781 / IL

## Parts Ordering

Each body-bonnet assembly is assigned a serial number, which can be found on the valve body. This same number also appears on the actuator nameplate when the valve body is shipped from the factory as part of a control valve assembly. Refer to the number when contacting your [Emerson sales office](#) or Local Business Partner for technical assistance or when ordering replacement parts.

When ordering replacement parts, also be sure to include the 11-character part number for each part required from the following parts list.

### **⚠ WARNING**

**Use only genuine Fisher replacement parts. Components that are not supplied by Emerson Automation Solutions should not, under any circumstances, be used in any Fisher valve, because they may void your warranty, might adversely affect the performance of the valve, and could cause personal injury and property damage.**

## Parts Kits

### Standard Packing Repair Kits (Non Live-Loaded)

Stem Diameter, mm (Inches) Yoke Boss Diameter, mm (Inches)	12.7 (1/2) 71 (2-13/16)	19.1 (3/4) 90 (3-9/16)	25.4 (1) 127 (5)	31.8 (1-1/4) 127 (5, 5H)
PTFE (Contains keys 6, 8, 10, 11, and 12)	RPACKX00022	RPACKX00032	RPACKX00342	RPACKX00352
Double PTFE (Contains keys 6, 8, 11, and 12)	RPACKX00052	RPACKX00062	RPACKX00362	RPACKX00372
PTFE/Composition (Contains keys 7, 8, 11, and 12)	RPACKX00082	RPACKX00092	---	---
Single Graphite Ribbon/Filament (Contains keys 7 [ribbon ring], 7 [filament ring], 8, and 11)	RPACKX00112	RPACKX00122	---	---
Single Graphite Ribbon/Filament (Contains keys 7 [ribbon ring], 7 [filament ring], and 11)	---	---	RPACKX00532	RPACKX00542
Single Graphite Ribbon/Filament (Contains keys 7 [ribbon ring], 7 [filament ring])	RPACKX00142	RPACKX00152	---	---
Double Graphite Ribbon/Filament (Contains keys 7 [ribbon ring], 7 [filament ring], 8, and 11)	RPACKX00172	RPACKX00182	---	---

### Repair Kits (ENVIRO-SEAL)

Stem Diameter, mm (Inches) Yoke Boss Diameter, mm (Inches)	12.7 (1/2) 71 (2-13/16)	19.1 (3/4) 90 (3-9/16)	25.4 (1) 127 (5)	31.8 (1-1/4) 127 (5, 5H)
Double PTFE (Contains keys 214, 215, 218)	RPACKX00202	RPACKX00212	RPACKX00222	RPACKX00232
Single Graphite ULF (Contains keys 207, 208, 209, 210, 214)	RPACKX00602	RPACKX00612	RPACKX00622	RPACKX00632
Duplex (Contains keys 207, 209, 214, 215)	RPACKX00302	RPACKX00312	RPACKX00322	RPACKX00332

### Retrofit Kits (ENVIRO-SEAL)

Stem Diameter, mm (Inches) Yoke Boss Diameter, mm (Inches)	12.7 (1/2) 71 (2-13/16)	19.1 (3/4) 90 (3-9/16)	25.4 (1) 127 (5)	31.8 (1-1/4) 127 (5, 5H)
Double PTFE (Contains keys 200, 201, 211, 212, 214, 215, 216, 217, 218, tag, cable tie)	RPACKXRT022	RPACKXRT032	RPACKXRT042	RPACKXRT052
Single Graphite ULF (Contains keys 200, 201, 207, 208, 209, 210, 211, 212, 214, 217, tag, cable tie)	RPACKXRT272	RPACKXRT282	RPACKXRT292	RPACKXRT302
Duplex (Contains keys 200, 201, 207, 209, 211, 212, 214, 215, 216, 217, tag, cable tie)	RPACKXRT222	RPACKXRT232	RPACKXRT242	RPACKXRT252

## Parts List

### Note

Contact your [Emerson sales office](#) or Local Business Partner for Part Ordering information.

## Bonnet Assembly (figure 16)

Key	Description
1	Bonnet If you need a bonnet as a replacement part, order by valve size and stem diameter, serial number, and desired material.
2	Baffle, for use with extension bonnet only
3	Packing Flange
4	Packing Flange Stud (2 req'd)
5	Packing Flange Nut (2 req'd)
6*	Packing Set or Arrangement
7*	Packing Ring, low chloride graphite
8	Packing Spring, 316 stainless steel
8	Lantern Ring, 316 stainless steel
10	Special Washer, 316 stainless steel
11*	Packing Box Ring, 316 stainless steel
12*	Upper Wiper, felt
13	Packing Follower, 316 stainless steel
14	Pipe Plug
14	Lubricator
14	Lubricator/Isolating Valve
15	Yoke Locknut
25	Actuator Mounting Stud (8 req'd)
26	Hex Nut (8 req'd)
35	Retaining Ring, for use with extension bonnet only

## Valve Body (figures 18-21)

1	Valve Body, order by valve size, serial number, and desired material
2*	Cage
3*	Valve Plug
4*	Valve Plug Stem
5*	Pin
6*	Seat Ring
7*	Seat Ring Retainer

Key	Description
8*	Piston Ring or Seal Ring
9*	Backup Ring
10*	Retaining Ring
10*	Retaining Ring (for EHT valve body only)
11*	Cage Gasket (2 req'd)
12*	Seat Ring O-Ring or Gasket
13	Bonnet Stud (8 req'd)
14	Hex Nut (8 req'd)
15	Flow Arrow
16	Drive Screw (4 req'd)
24	Anti-seize Lubricant
25	Seat Ring Retainer Tool (see figure 9) 416 stainless steel
26*	O-Ring (for valve with Cavitrol III trim only), ethylene/propylene
27	Nameplate
28	Nameplate Wire
29	Bonnet Washer
29	Flat Washer (8 req'd)
30*	Piston Ring (for EHT with Level D Whisper Trim III cage only)
33	Belleville Washer, N07718 (8 req'd)
63*	Anti-Extrusion Ring

## C-seal Trim (figure 10)

2*	Cage
3*	Valve Plug/Retainer
4*	Valve Plug Stem, S20910
6*	Seat Ring
8*	Piston Ring, graphite (2 req'd)
64*	C-seal, N07718

## TSO Trim (figure 7)

2*	Cage
4*	Seat Ring
5*	Plug/Stem Assembly
8*	Seal Ring
63*	Anti-Extrusion Ring
9*	Back Up Ring
10*	Retaining Ring

Figure 16. Fisher EH Bonnet Assembly

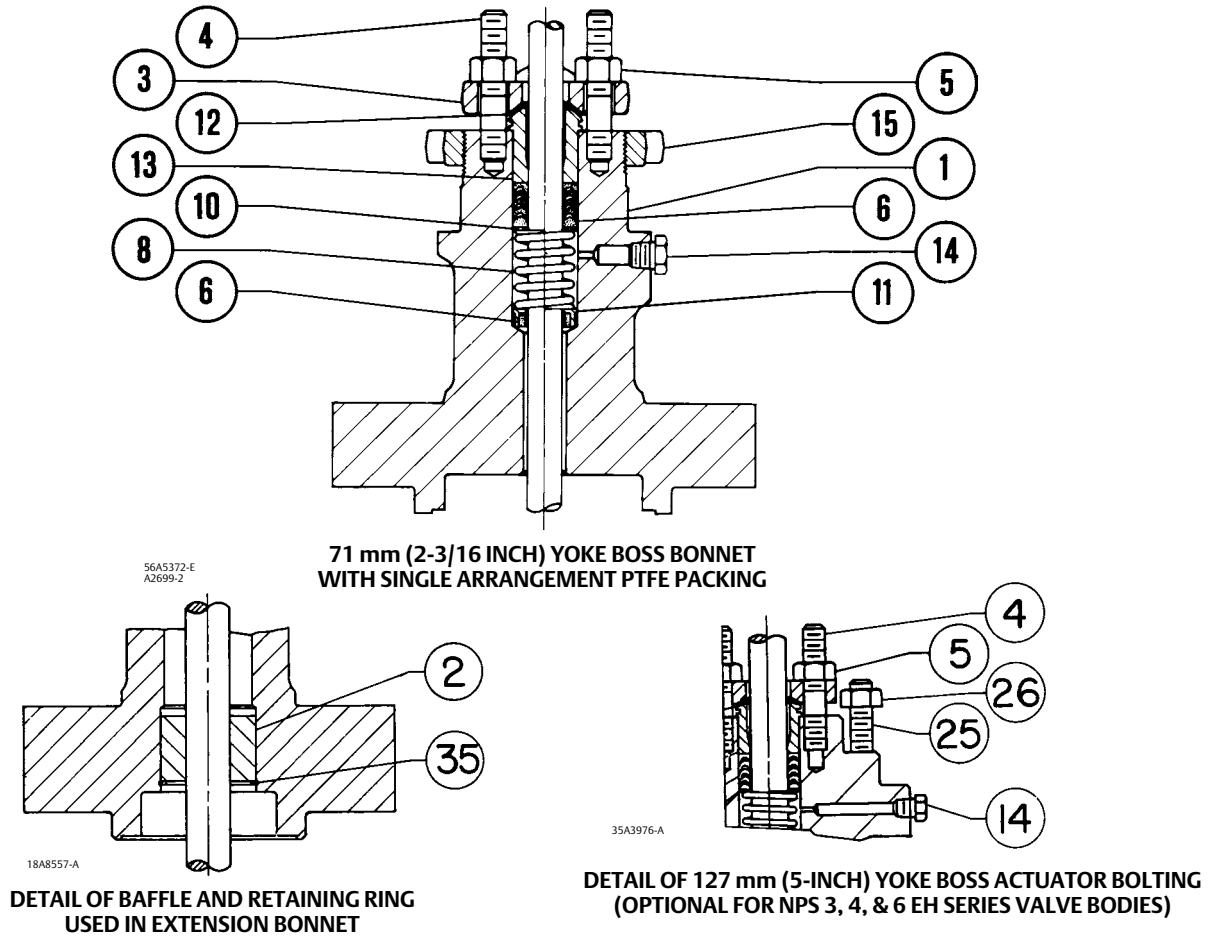


Figure 17. Belleville Washer Body-to-Bonnet Bolting

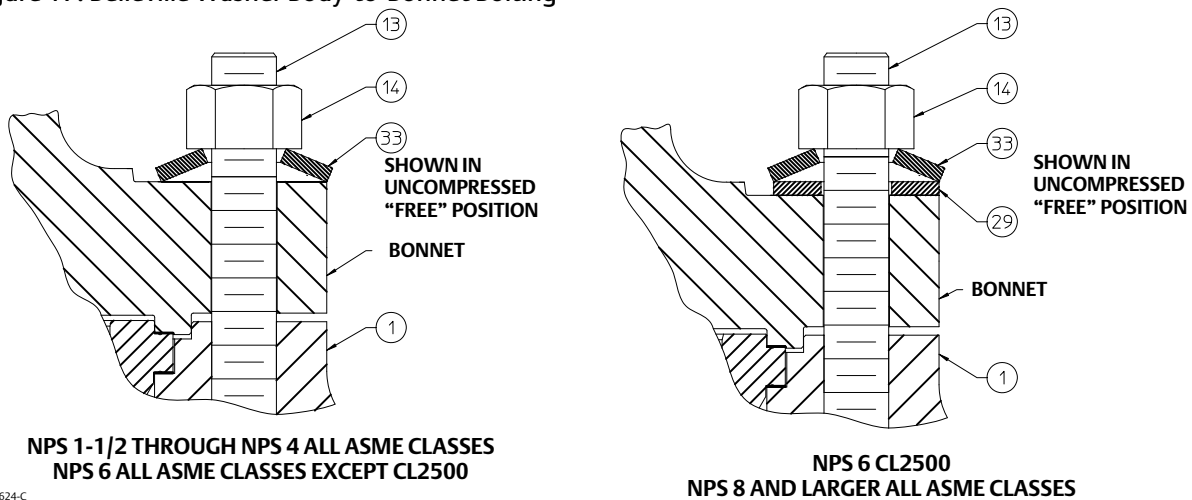
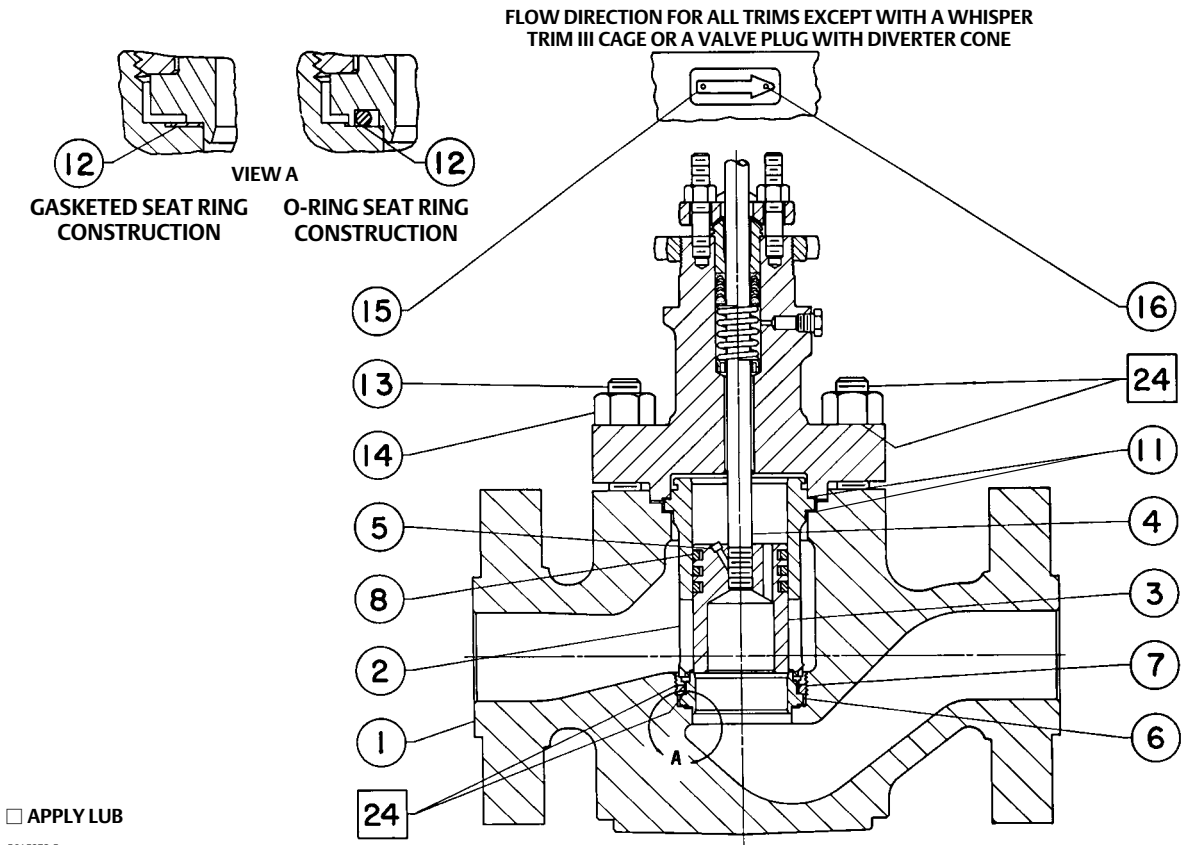


Figure 18. Fisher EHD Valve

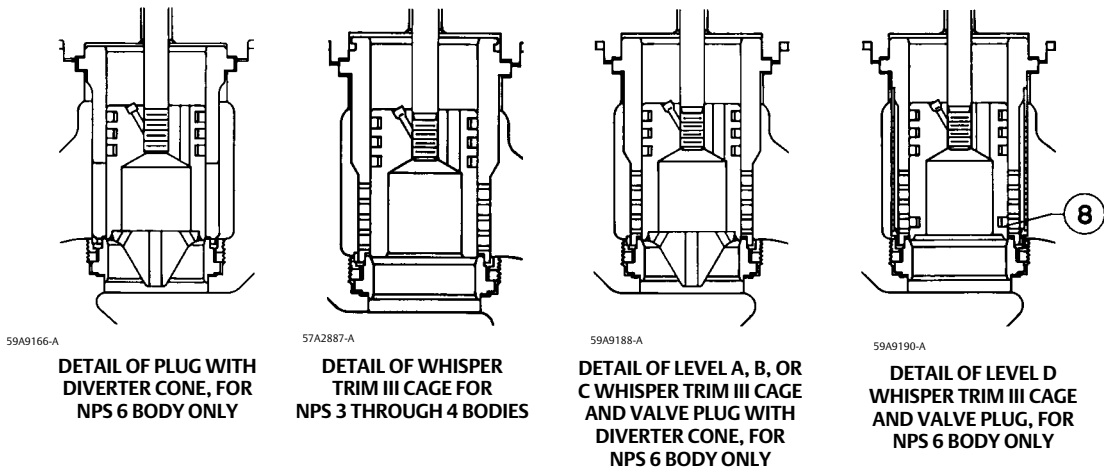


□ APPLY LUB

56A5372-F

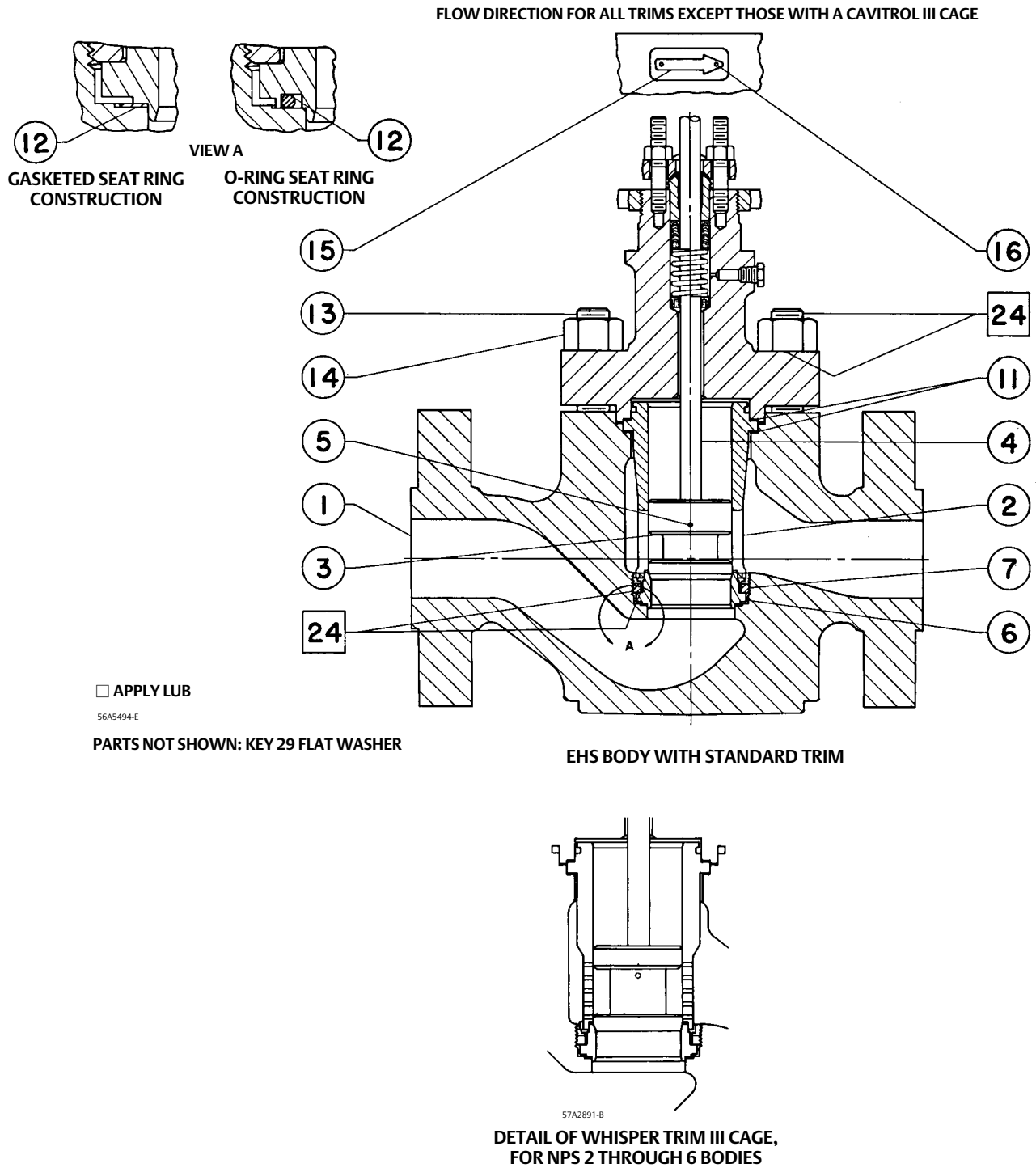
PARTS NOT SHOWN: KEY 29 FLAT WASHER

EHD BODY WITH STANDARD TRIM



ALTERNATE CONFIGURATIONS  
REFERENCE STANDARD TRIM KEY NUMBERS EXCEPT AS SHOWN

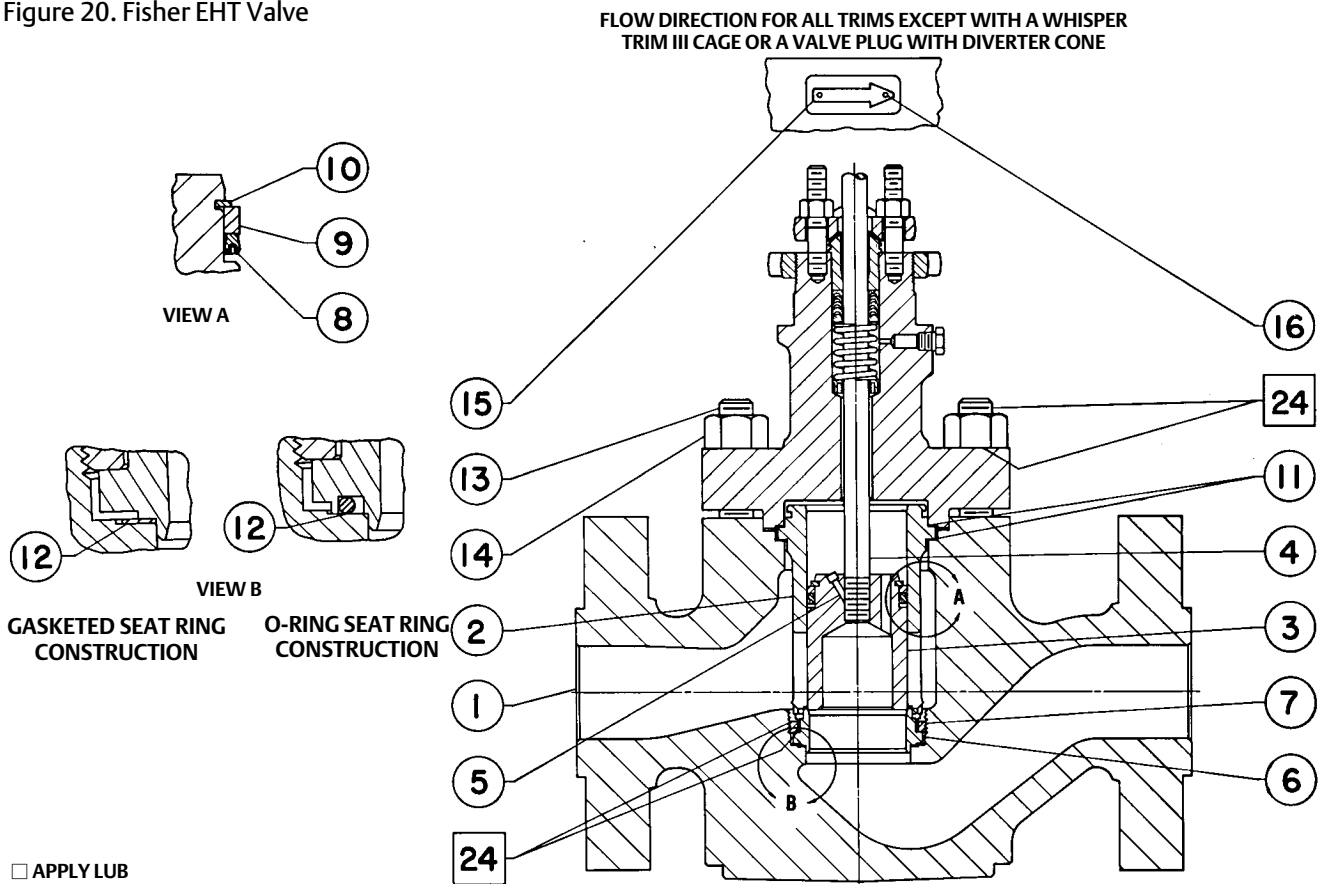
Figure 19. Fisher EHS Valve



ALTERNATE CONFIGURATIONS  
REFERENCE STANDARD TRIM KEY NUMBERS EXCEPT AS SHOWN



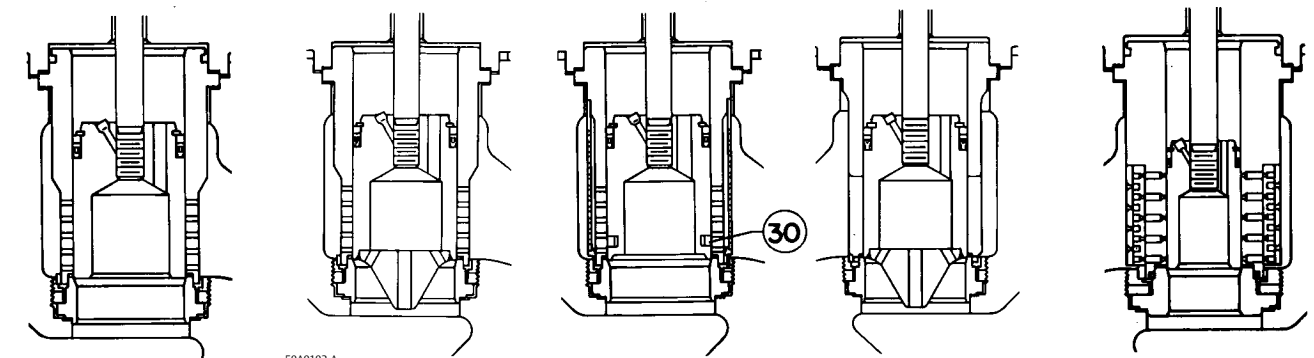
Figure 20. Fisher EHT Valve



56A5487-E

PARTS NOT SHOWN: KEY 29 FLAT WASHER

EHT BODY WITH STANDARD TRIM



57A2889-A  
DETAIL OF WHISPER TRIM III CAGE FOR NPS 3 THROUGH 4 BODIES

59A9192-A  
DETAIL OF LEVEL A, B, OR C WHISPER TRIM III CAGE AND VALVE PLUG WITH DIVERTER CONE, FOR NPS 6 BODY ONLY

59A9194-A  
DETAIL OF LEVEL D WHISPER TRIM III CAGE AND VALVE PLUG, FOR NPS 6 BODY ONLY

59A9168-A  
DETAIL OF VALVE PLUG WITH DIVERTER CONE, FOR NPS 6 BODY ONLY

57A2883-B  
DETAIL OF 3-STAGE CAVITROL III CAGE, FOR ALL BODIES EXCEPT NPS 1 AND CL2500 NPS 2 BODIES (2-STAGE CAGE IS AVAILABLE FOR NPS 3 THROUGH 6 BODIES)

ALTERNATE CONFIGURATIONS  
REFERENCE STANDARD TRIM KEY NUMBERS EXCEPT AS SHOWN

Figure 21. Typical Cavitrol III Constructions

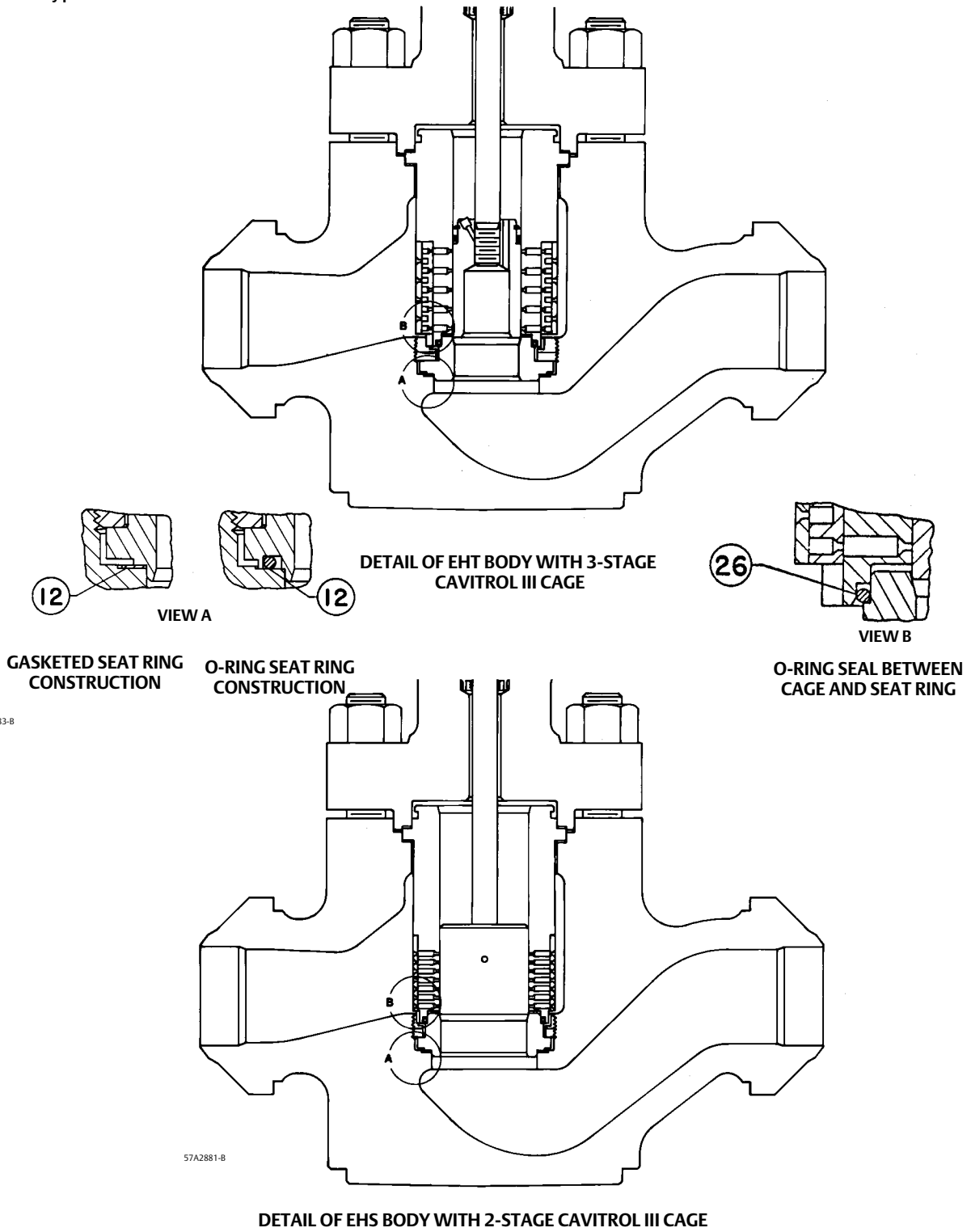
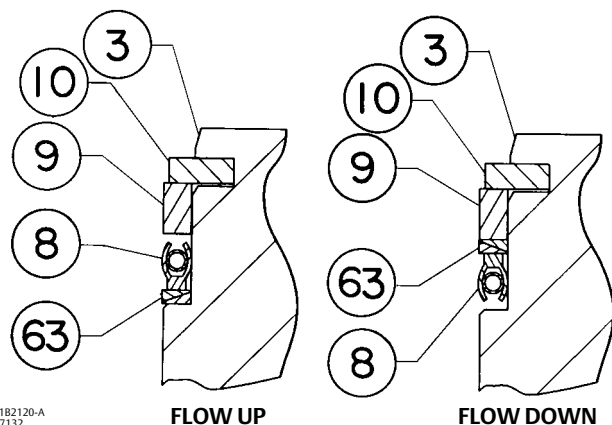


Table 12. Valve Plug Diameters and Operating Temperatures

CAGE MATERIAL	STEM MATERIAL	OPERATING TEMPERATURE RANGE		DIAMETER CODE	VALVE BODY DESIGN
		°C	°F		
S31600 (316 Stainless Steel) Chrome-coated	S31600	-198 to +427	-325 to +800	A	EHD, EHS
	S31600 Chrome-coated	-29 to +593	-20 to +1100		
S31600 ENC (NACE)	S20910	-40 to +232	-40 to +450	A	EHD, EHS
S17400 (17-4PH Stainless Steel) H1150 (NACE)	S20910	-40 to +232	-40 to +450	A	EHS
S17400 H1150 (NACE)	S20910	-40 to +232	-40 to +450	B	EHD
S31600 Chrome-coated	S31600	-198 to +427	-325 to +800	B	EHS
	S31600 Chrome-coated	-29 to +593	-20 to +1100		
S31600 ENC (NACE)	S20910	-40 to +232	-40 to +450	B	EHS
S42200 (422 Stainless Steel) Ion Nitride	S31600 Chrome-coated	427 to 566	+800 to 1050	C	EHD, EHS
S42200 Ion Nitride	S31600 Chrome-coated	427 to 510	+800 to 950	D	EHD, EHS
S31600 Chrome-coated	S31600	-198 to +427	-325 to +800	D	EHD, EHS
	S31600 Chrome-coated	-29 to +593	-20 to +1100		
S31600 ENC (NACE)	S20910	-40 to +232	-40 to +450	D	EHD, EHS
S42200 Ion Nitride	S31600 Chrome-coated	427 to 510	+800 to 950	E	EHD, EHS
S42200 Ion Nitride	S31600 Chrome-coated	510 to 566	+950 to 1050	F	EHD, EHS
S31600 Chrome-coated	S31600	-198 to +427	-325 to +800	K	EHD
	S31600 Chrome-coated	-29 to +593	-20 to +1100		
S31600 ENC (NACE)	S20910	-40 to +232	-40 to +450	K	EHD

Figure 22. NPS 3 to 6 Fisher EHT Valve Using PEEK Anti-Extrusion Rings



2182120-A  
A7132

**Actuator Groups by Type Number**

<b>Group 1</b> 54 mm (2-1/8 Inch), 71 mm (2-13/16 Inch), or 90 mm (3-9/16 Inch) Yoke Boss	<b>Group 101</b> 127 mm (5 Inch) Yoke Boss	<b>Group 404</b> 127 mm (5 Inch, 5H) Yoke Boss 101.6 mm (4 Inch) Maximum Travel	<b>Group 408</b> 177.8 mm (5H, 7 Inch) Yoke Boss 101.6 mm (4 Inch) Maximum Travel
472 & 473 585C, 585CR (50.8 mm [2 inch] maximum travel) 1B & 655 657 & 667—76.2 mm (3 Inch) maximum travel 657-4, 667-4 (76.2 mm [3 inch] travel) 1008—Except 90 mm (3-9/16 Inch) yoke boss with 50.8 mm (2 inch) travel 3024C, 3025 685SE, 685SR (76.2 mm [3 inch] maximum travel)	667, 667 MO	667, 667-4 3025 (ATO)	657 Size 100 1008 Size 100 3025 (ATC)
	<b>Group 401</b> 90.5 mm (3-9/16 Inch) Yoke Boss 88.9 to 101.6 mm (3.25 to 4 inch) Travel	<b>Group 405</b> 127 mm (5 Inch, 5H) Yoke Boss 101.6 mm (4 Inch) Maximum Travel	<b>Group 409</b> 177.8 mm (5H, 7 Inch) Yoke Boss 101.6 mm (4 Inch) Maximum Travel
	657, 657 MO 667, 667 MO 657-4, 657-4 MO 667-4, 667-4 MO 3025 685SE, 685SR	657 MO, 657-4 MO	667 Size 100 3025 (ATO)
	<b>Group 406</b> 127 mm (5 Inch, 5H) Yoke Boss 101.6 mm (4 Inch) Maximum Travel	<b>Group 801</b> 90.5 mm (3-9/16 Inch) Yoke Boss 203.2 mm (8 Inch) Maximum Travel	
<b>Group 100</b> 127 mm (5 Inch, 5H) Yoke Boss	<b>Group 402</b> 90.5 mm (3-9/16 Inch) Yoke Boss 101.6 mm (4 Inch) Maximum Travel	667 MO, 667-4 MO	585C, 585C MO Size 60 685SE, 685SR
		<b>Group 407</b> 127 mm (5 Inch, 5H) Yoke Boss 101.6 mm (4 Inch) Maximum Travel	<b>Group 802</b> 127 mm (5 Inch, 5H) Yoke Boss 203.2 mm (8 Inch) Maximum Travel
472, 473 585C, 585C MO 657, 657 MO 1008 PDTC	585C MO Size 60	585C, 585C MO 657 3025 (ATC) 685SE, 685SR	585C, 585C MO 685SE, 685SR
	<b>Group 403</b> 90.5 mm (3-9/16 Inch) Yoke Boss 101.6 mm (4 Inch) Maximum Travel		
	585C Size 60 1008 Size 50		

\*Recommended spare parts

Neither Emerson, Emerson Automation Solutions, nor any of their affiliated entities assumes responsibility for the selection, use or maintenance of any product. Responsibility for proper selection, use, and maintenance of any product remains solely with the purchaser and end user.

Fisher, Cavitrol, ENVIRO-SEAL, and Whisper Trim are marks owned by one of the companies in the Emerson Automation Solutions business unit of Emerson Electric Co. Emerson Automation Solutions, Emerson, and the Emerson logo are trademarks and service marks of Emerson Electric Co. All other marks are the property of their respective owners.

The contents of this publication are presented for informational purposes only, and while every effort has been made to ensure their accuracy, they are not to be construed as warranties or guarantees, express or implied, regarding the products or services described herein or their use or applicability. All sales are governed by our terms and conditions, which are available upon request. We reserve the right to modify or improve the designs or specifications of such products at any time without notice.

Emerson Automation Solutions  
Marshalltown, Iowa 50158 USA  
Sorocaba, 18087 Brazil  
Cernay 68700 France  
Dubai, United Arab Emirates  
Singapore 128461 Singapore

www.Fisher.com

