

Micro Motion[®] Model 2700 Transmitters with PROFIBUS-PA



Safety messages

Safety messages are provided throughout this manual to protect personnel and equipment. Read each safety message carefully before proceeding to the next step.

Other information

Full product specifications can be found in the product data sheet. Troubleshooting information can be found in the configuration manual. Product data sheets and manuals are available from the Micro Motion web site at www.emerson.com.

Return policy

Follow Micro Motion procedures when returning equipment. These procedures ensure legal compliance with government transportation agencies and help provide a safe working environment for Micro Motion employees. Micro Motion will not accept your returned equipment if you fail to follow Micro Motion procedures.

Return procedures and forms are available on our web support site at www.emerson.com, or by phoning the Micro Motion Customer Service department.

Emerson Flow customer service

Email:

- Worldwide: flow.support@emerson.com
- Asia-Pacific: APflow.support@emerson.com

Telephone:

North and South America		Europe and Middle East		Asia Pacific	
United States	800-522-6277	U.K.	0870 240 1978	Australia	800 158 727
Canada	+1 303-527-5200	The Netherlands	+31 (0) 704 136 666	New Zealand	099 128 804
Mexico	+41 (0) 41 7686 111	France	0800 917 901	India	800 440 1468
Argentina	+54 11 4837 7000	Germany	0800 182 5347	Pakistan	888 550 2682
Brazil	+55 15 3413 8000	Italy	8008 77334	China	+86 21 2892 9000
		Central & Eastern	+41 (0) 41 7686 111	Japan	+81 3 5769 6803
		Russia/CIS	+7 495 981 9811	South Korea	+82 2 3438 4600
		Egypt	0800 000 0015	Singapore	+65 6 777 8211
		Oman	800 70101	Thailand	001 800 441 6426
		Qatar	431 0044	Malaysia	800 814 008
		Kuwait	663 299 01		
		South Africa	800 991 390		
		Saudi Arabia	800 844 9564		
		UAE	800 0444 0684		

Contents

Chapter 1	Before you begin	7
	1.1 About this manual	7
	1.2 Transmitter model code	7
	1.3 Profibus-PA functionality	7
	1.4 Determining version information	8
	1.5 Communication tools	9
	1.6 Additional documentation and resources	9
Chapter 2	Startup	11
	2.1 Applying power	11
	2.2 Setting the node address	11
	2.3 Setting the IO mode	11
	2.4 Make a startup connection to the transmitter	13
	2.5 Verify the zero	13
Chapter 3	Introduction to configuration and commissioning	17
	3.1 Planning the configuration	17
	3.2 Pre-configuration worksheet	19
	3.3 Restoring a working configuration	19
Chapter 4	Configuration	21
	4.1 Overview	21
	4.2 Default target mode	21
	4.3 Configuration map	21
	4.4 Configuring the analog input function block channels	23
	4.5 Configuring the totalizer block mode	25
	4.6 Configuring standard volume flow measurement for gas	27
	4.7 Changing the measurement units	29
	4.8 Configuring the petroleum measurement application	34
	4.9 Configuring the concentration measurement application	37
	4.10 Changing the output scale	40
	4.11 Changing process alerts	41
	4.12 Configuring alert status severity	44
	4.13 Changing the damping values	47
	4.14 Changing two-phase flow (slug flow) limits and duration	49
	4.15 Configuring cutoffs	50
	4.16 Changing the measurement mode parameter	51
	4.17 Configuring sensor parameters	52
	4.18 Configuring the display	53

	4.19 Enabling LD optimization	59
	4.20 Configuring pressure compensation	59
	4.21 Configuring temperature compensation	62
Chapter 5	Configure device options and preferences	65
	5.1 Configure the transmitter display	65
	5.2 Enable or disable operator actions from the display	68
	5.3 Configure security for the display menus	70
	5.4 Configure alert handling	71
	5.5 Configure informational parameters	74
Chapter 6	Complete the configuration	77
	6.1 Test or tune the system using sensor simulation	77
	6.2 Back up transmitter configuration	79
Chapter 7	Transmitter operation	81
	7.1 Record the process variables	81
	7.2 Viewing process variables	81
	7.3 I&M functions	82
	7.4 Using sensor simulation mode	83
	7.5 Accessing diagnostic information with a PROFIBUS host	83
	7.6 Viewing transmitter status and alerts	83
	7.7 View and acknowledge status alerts	85
	7.8 Using the totalizers and inventories	88
	7.9 Read totalizer and inventory values	90
	7.10 Start and stop totalizers and inventories	91
	7.11 Reset totalizers	92
	7.12 Reset inventories	93
Chapter 8	Measurement support	95
	8.1 Options for measurement support	95
	8.2 Calibration	95
	8.3 Comparison and recommendations	96
	8.4 Use Smart Meter Verification (SMV)	97
	8.5 Zero the meter	107
	8.6 Meter validation and meter factors	109
	8.7 Performing density calibration	112
Chapter 9	Troubleshooting	119
	9.1 Guide to troubleshooting topics	119
	9.2 Transmitter does not operate	119
	9.3 Transmitter does not communicate	119
	9.4 Function blocks in OOS mode	119
	9.5 Zero or calibration failure	120
	9.6 Output problems	120

9.7	Status alerts	125
9.8	Diagnosing wiring problems	131
9.9	Checking two-phase flow (slug flow)	132
9.10	Obtaining and checking the diagnostic variables	132
9.11	Checking the core processor	135
9.12	Checking sensor coils and RTD	140
Appendix A	Flow meter installation types and components	147
Appendix B	Using the transmitter display	159
B.1	Components of the transmitter interface	159
B.2	Use the optical switches	159
B.3	Access and use the display menu system	159
B.4	Display codes for process variables	164
B.5	Codes and abbreviations used in display menus	165
B.6	Display menus	168
Appendix C	Using ProLink III with the transmitter	175
C.1	Basic information about ProLink III	175
C.2	Connect with ProLink III	176
Appendix D	PROFIBUS-PA status byte	179
Appendix E	Slave diagnostic response bytes	185
Appendix F	Model 2700 PROFIBUS block parameters	195
F.1	Slot identification	196
F.2	Physical block	197
Appendix G	NE53 history	391

1 Before you begin

1.1 About this manual

This manual helps you configure, commission, use, maintain, and troubleshoot Micro Motion Model 2700 transmitters with PROFIBUS-PA.

Important

This manual assumes that the following conditions apply:

- The transmitter has been installed correctly and completely according to the instructions in the transmitter installation manual
 - The installation complies with all applicable safety requirements
 - The user is trained in local and corporate safety standards
-

1.2 Transmitter model code

You can verify that this manual pertains to your transmitter by ensuring the model code on the transmitter tag matches the format.

Example:

The transmitter has a model number of the following form: 2700(***/G/**/**/**).

G Output Option Code of PROFIBUS-PA

1.3 Profibus-PA functionality

The transmitter supports the following methods of configuration and operation:

- Configuration methods:
 - Enhanced Device Description (EDD) language for use with a PROFIBUS configuration tool such as Siemens[®] Simatic[®] Process Device Manager (PDM). In this manual, the term "EDD" is used to refer to this type of configuration
 - FDT/DTM technology for use with DTM files that run inside a frame application (FDT) such as PACTware[®]
 - Direct read and write of PROFIBUS-PA bus parameters
- Operation methods:
 - GSD file with a PROFIBUS host, which is used to get the definition of the cyclic process variables that the host uses.
The transmitter supports two GSD options--
 1. Profile-specific, which is created by PNO
 2. Manufacturer-specific, which is created by Micro Motion in order to implement a larger set of function blocks.

Note

The GSD file archive from the Emerson website contains both types of GSD files.

See [Setting the IO mode](#) for more information about the two GSD options.

In this manual, the term "host" or "PROFIBUS host" is used to refer to this type of operation.

- Enhanced Configuration tool Device Description (EDD) files. The device description file provides operation and configuration capabilities.
Specific manufacturers use different configuration tools. Here are the three that Micro Motion supplies:
 1. Enhanced Device Description Language (EDDL) files, which are used by the AMS Device Manager configuration tool.
 2. PDM files, which are used by Simatic PDM software configuration tool.
 3. DTM files, which are used by FDT frame applications like PACTware for configuration purposes.
- Identification and maintenance (I&M) functions:
 - I&M 0
 - I&M 1
 - I&M 2
 - PA I&M 0

The transmitter supports both classic and condensed status byte formats. (Refer to [PROFIBUS-PA status byte](#)).

- Class mode conforms to the PROFIBUS-PA Profile v3.01, Section 3.7.3.6
- Condensed mode conforms to the PROFIBUS-PA Specification June 2005 Amendment 2 to the PROFIBUS Profile v3.01, Condensed Status and Diagnostic Messages v1.0.

1.4 Determining version information

The following table lists the version information you may need to know and describes how to obtain the information. Make sure you have the latest versions of the transmitter and ProLink III.

Note

The hardware for transmitters with v2.x and lower firmware is incompatible with the hardware needed to support v3.0 and higher firmware. To upgrade from an earlier firmware version to v3.0 or higher firmware requires hardware replacement.

Table 1-1: Communication tools for Model 2700 transmitter with PROFIBUS-PA

Component	Tool	Method
Transmitter software	With ProLink III	Device Tools > Device Information > Transmitter Electronics > Software Revision
	With EDD	Overview > Device Information > Revision > Software
	With display	OFF-LINE MAINT > SWRev
Core processor software	With ProLink III	Device Tools > Device Information > Enhanced Core Processor > Software Revision
	With EDD	Not available
	With display	OFF-LINE MAINT > SWRev
ProLink III	With ProLink III	Help > About ProLink III

Table 1-1: Communication tools for Model 2700 transmitter with PROFIBUS-PA (continued)

Component	Tool	Method
GSD version	Text editor	Open file V4x_057A.gsd or PA139742.GSD and check parameter GSD_REVISION
EDD version	With EDD	Overview > Device Information > Revision > DD

Both EDD and DTM files can be downloaded from <http://www.emerson.com/en-us/support/software-downloads-drivers>. Search for Device Install Kits to access the "Search For DD, DTM, and GSD Files" page.

You can find the *Commissioning MVD Profibus PA Documentation Supplement* at <http://www.emerson.com/documents/automation/commissioning-mvd-profibus-pa-en-64054.pdf>. This supplement assists you with connecting to the transmitter with Siemens Simatic® Process Device Manager (PDM).

Basic information on using the display is provided in [Using the transmitter display](#).

1.5 Communication tools

Most of the procedures described in this manual require the use of a communication tool. The following table lists the communication tools that can be used, as well as their functionality and requirements.

Note

You can use ProLink III, the EDD, or PROFIBUS bus parameters for transmitter setup and maintenance. It is not necessary to have more than one of these methods available.

Table 1-2: Communication tools for Model 2700 transmitter with PROFIBUS-PA

Tool	View/operation	Setup/maintenance	Requirements
Transmitter display	Partial	Partial Setup/Maintenance	Transmitter with display
ProLink III	Full	Full	ProLink III v3.2 or later
Host	Partial	None	GSD file V4x_057A.gsd or PA139742.GSD
EDD	Full	Full	PDM file set
DTM	Full	Full	DTM file set
Bus parameters	Full	Full	None

Basic information on using the display is provided in [Using the transmitter display](#).

1.6 Additional documentation and resources

Topic	Document
Connecting the transmitter to Simatic PDM	<i>Commissioning MVD Profibus PA Documentation Supplement</i>

Topic	Document
Hazardous area installation	See the approval documentation shipped with the transmitter, or download the appropriate documentation at www.emerson.com .
Product Data Sheet	<i>Micro Motion Series 1000 and Series 2000 Transmitters with MVD™ Technology Product Data Sheet</i>
Sensor	Sensor documentation
Transmitter installation	<i>Micro Motion® Model 1700 and 2700 Installation Manual</i>

All documentation resources are available at www.emerson.com or on the user documentation DVD.

2 Startup

2.1 Applying power

Before you apply power to the flow meter, close and tighten all housing covers.



DANGER

Operating the flow meter without covers in place creates electrical hazards that can cause death, injury, or property damage. Make sure all covers are in place before applying power to the transmitter.

Turn on the electrical power at the power supply. The flow meter will automatically perform diagnostic routines. If the transmitter has a display, the status LED will turn green and begin to flash when the transmitter has finished its startup diagnosis.

Note

If this is the initial startup, or if power has been off long enough to allow components to reach ambient temperature, the flow meter is ready to receive process fluid approximately one minute after power-up. However, it may take up to ten minutes for the electronics in the flow meter to reach thermal equilibrium. During this warm-up period, you may observe minor measurement instability or inaccuracy.

2.2 Setting the node address

The factory default for the node address is 126. To set the node address:

- With the display, choose **OFF-LINE > CONFIG > ADDRESS PBUS**.
- With ProLink III, choose **Device Tools > Configuration > Communications > Profibus-PA**.
- With a PROFIBUS host, use the change address function of the host.

2.3 Setting the IO mode

The transmitter can function in two different Modes: Profile-specific and Manufacturer-specific. The factory default is Manufacturer-specific.

About this task

The two modes control which function blocks are available for use, and whether the format of the status byte is "classic" or condensed". (Defined in more detail in [PROFIBUS-PA status byte](#).)

- In Profile-specific mode, the transmitter has the use of three AI blocks and one totalizer block. The status byte output format defaults to classic mode.
- In Manufacturer-specific mode, the transmitter has the use of four AI blocks, four totalizer blocks, and two AO blocks. The status byte output format defaults to condensed mode.

[Table 2-1](#) shows the slot identifications and blocks permitted by each mode.

Note

You must select modules exactly as described in the table, or select an empty module for slots that you do not intend to use. If any modules are left unconfigured, the transmitter will not send data.

Table 2-1: I/O mode slot configuration

Slot	Profile-specific mode	Manufacturer-specific mode
1	AI 1	AI 1
2	AI 2	AI 2
3	AI 3	AI 3
4	Totalizer 1	Totalizer 1
5		AI 4
6		Totalizer 2
7		Totalizer 3
8		Totalizer 4
9		AO 1
10		AO 2

To set the I/O mode of the transmitter:

There are two GSD files that correspond to the two I/O modes. If you are using a PROFIBUS host with GSD files to operate the transmitter, you must use the GSD that corresponds to the I/O mode you have chosen. The following table lists the GSD files names. Load the correct GSD file into your PROFIBUS host or configuration tool.

Note

If you use the local display, the Ident number is the only available option.

Table 2-2: PROFIBUS GSD file names

Name	Ident number	GSD file name
Profile specific	0	PA139742.GSD
Manufacturer specific	1	V4x_057A.gsd

Note

Set the I/O mode in the Physical Block before loading the GSD files.

Procedure

1. Determine the method you are using to set the I/O mode in the Physical Block.
 - If you are using EDD files, go to [Step 2](#).
 - If you are using bus parameters, go to [Step 3](#).
 - If you are using the local display, go to [Step 5](#).
2. From the EDD, choose **MMI Coriolis Flow > Physical Block > Device** and specify the Ident Number.

3. For bus parameters, select **I/O Mode** .
4. Then select **Block; Physical Block (Slot 0) Index: 40 (identification number selector)**
5. From the display, go to the Config section to **Ident SEL** and specify either 0 or 1. Refer to [Figure B-3](#).

2.3.1 Overriding the status byte format

Each I/O mode has a default status byte format -- classic or condensed.

About this task

For more information about status byte format, refer to [PROFIBUS-PA status byte](#).

Use the following procedure to override this format. To set the I/O mode of the transmitter:

Procedure

1. Determine the method you are using to set the I/O mode:
 - If you are using EDD files, go to [Step 2](#).
 - If you are using bus parameters, go to [Step 4](#).
2. From the EDD, choose **MMI Coriolis Flow > Physical Block > Features supported**.
3. Go to Condensed Status and make the change.
4. For bus parameters, select **Status byte format** .
5. Then select **Block; Physical Block 1 (Slot 0) Index: 43 (Condensed status diagnostics)**.

2.4 Make a startup connection to the transmitter

About this task

For all configuration tools except the display, you must have an active Profibus connection to the transmitter for configuration purposes.

2.5 Verify the zero

Verifying the zero helps you determine if the stored zero value is appropriate to your installation, or if a field zero can improve measurement accuracy.

About this task

The zero verification procedure analyzes the Live Zero value under conditions of zero flow, and compares it to the Zero Stability range for the sensor. If the average Live Zero value is within a reasonable range, the zero value stored in the transmitter is valid. Performing a field calibration will not improve measurement accuracy.

Important

In most cases, the factory zero is more accurate than the field zero. Do not zero the meter unless one of the following is true:

- The zero is required by site procedures.
- The stored zero value fails the zero verification procedure.

Procedure

1. Allow the flowmeter to warm up for at least 20 minutes after applying power.
2. Run the process fluid through the sensor until the sensor temperature reaches the normal process operating temperature.
3. Stop flow through the sensor by shutting the downstream valve, and then the upstream valve if available.
4. Verify that the sensor is blocked in, that flow has stopped, and that the sensor is completely full of process fluid.
5. From ProLink III, choose **Device Tools > Calibration > Zero Verification and Calibration > Verify Zero** and wait until the procedure completes.
6. Observe the drive gain, temperature, and density readings. If they are stable, check the **Live Zero** or **Field Verification Zero** value. If the average value is close to 0, you should not need to zero the meter.
7. If the zero verification procedure fails:
 - a) Confirm that the sensor is completely blocked in, that flow has stopped, and that the sensor is completely full of process fluid.
 - b) Verify that the process fluid is not flashing or condensing, and that it does not contain particles that can settle out.
 - c) Remove or reduce sources of electromechanical noise if appropriate.
 - d) Repeat the zero verification procedure.
 - e) If it fails again, zero the meter.

Postrequisites

Restore normal flow through the sensor by opening the valves.

Related tasks

[Zero the meter](#)

2.5.1 Terminology used with zero verification and zero calibration

Term	Definition
Zero	In general, the offset required to synchronize the left pickoff and the right pickoff under conditions of zero flow. Unit = microseconds.
Factory Zero	The zero value obtained at the factory, under laboratory conditions.
Field Zero	The zero value obtained by performing a zero calibration outside the factory.
Prior Zero	The zero value stored in the transmitter at the time a field zero calibration is begun. May be the factory zero or a previous field zero.

Term	Definition
Manual Zero	The zero value stored in the transmitter, typically obtained from a zero calibration procedure. It may also be configured manually. Also called “mechanical zero” or “stored zero”.
Live Zero	The real-time bidirectional mass flow rate with no flow damping or mass flow cutoff applied. An adaptive damping value is applied only when the mass flow rate changes dramatically over a very short interval. Unit = configured mass flow measurement unit.
Zero Stability	A laboratory-derived value used to calculate the expected accuracy for a sensor. Under laboratory conditions at zero flow, the average flow rate is expected to fall within the range defined by the Zero Stability value ($0 \pm$ Zero Stability). Each sensor size and model has a unique Zero Stability value. Statistically, 95% of all data points should fall within the range defined by the Zero Stability value.
Zero Calibration	The procedure used to determine the zero value.
Zero Time	The time period over which the Zero Calibration procedure is performed. Unit = seconds.
Field Verification Zero	A 3-minute running average of the Live Zero value, calculated by the transmitter. Unit = configured mass flow measurement unit.
Zero Verification	A procedure used to evaluate the stored zero and determine whether or not a field zero can improve measurement accuracy.

3 Introduction to configuration and commissioning

3.1 Planning the configuration

Refer to the configuration overview flowchart below to plan transmitter configuration. In general, perform configuration steps in the order shown here.

Note

Depending on your installation and application, some configuration tasks may be optional. This manual provides information on topics that are not included in the configuration overview flowchart, such as using the transmitter, troubleshooting, and calibration procedures. Be sure to review these topics as required.

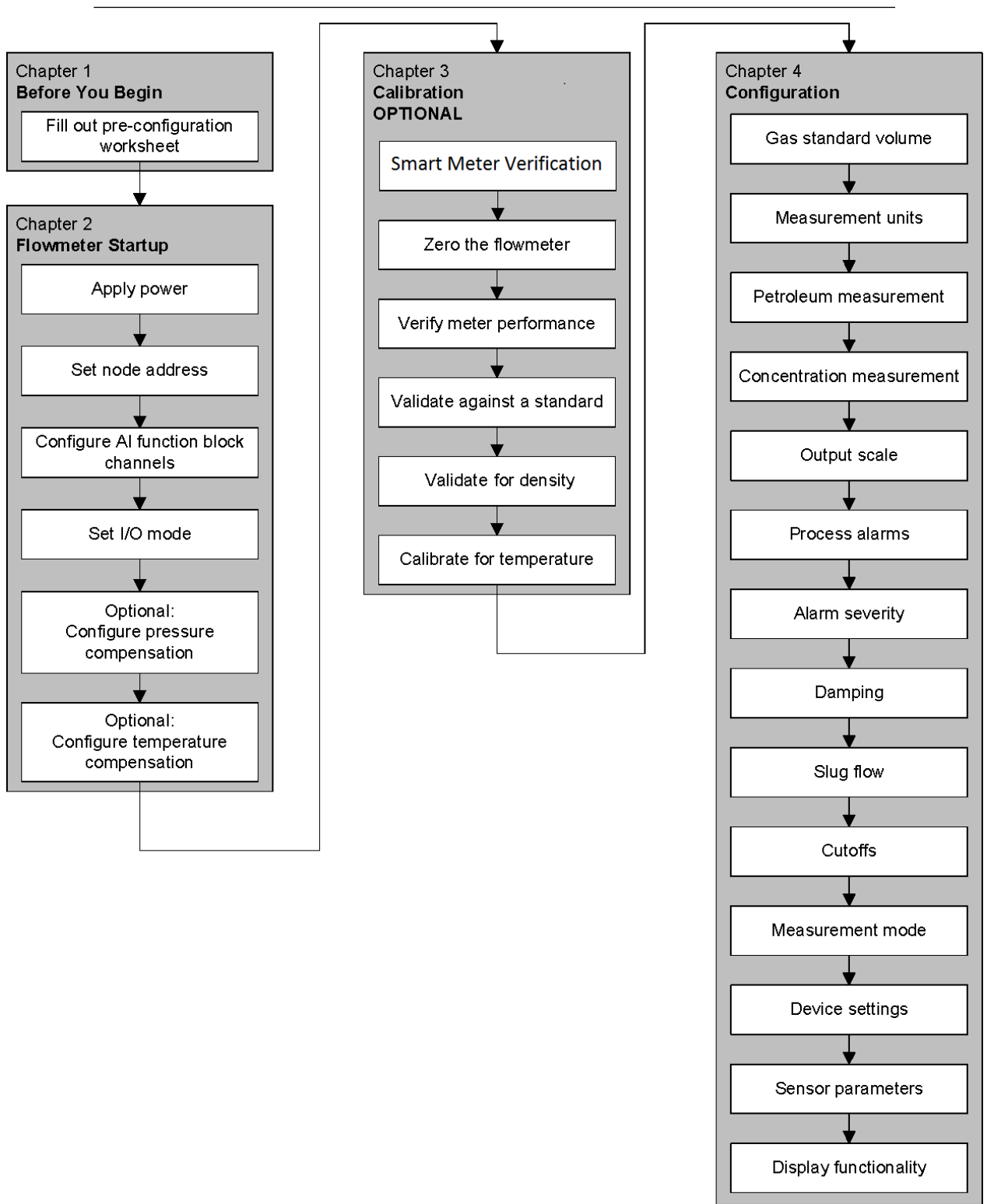

3.2 Pre-configuration worksheet

The pre-configuration worksheet provides a place to record information about your flow meter and your application. This information will affect your configuration options as you work through this manual. You may need to consult with transmitter installation or application process personnel to obtain the required information.

If you are configuring multiple transmitters, make copies of this worksheet and fill one out for each individual transmitter.

Table 3-1: Pre-configuration worksheet for transmitters and sensors

Transmitter	Sensor
Model code	Model code
Serial number	Serial number
Software version	
Node Address	

Table 3-2: Pre-configuration worksheet for transmitter -- measurement units for enumerated process variables

Measurement units	
Mass flow	Volume flow
Density	Temperature
External Pressure	

Table 3-3: Pre-configuration worksheet for transmitter -- installed applications

Installed applications	
Meter verification software	<input type="checkbox"/>
Petroleum measurement application	<input type="checkbox"/>
Concentration measurement application	<input type="checkbox"/>

3.3 Restoring a working configuration

At times it may be easier to start from a known working configuration than to troubleshoot the existing configuration. To do this, you can::

- Restore a configuration file saved through ProLink III, if one is available. In ProLink III, select **Device Tools > Configuration Transfer > Save Load Configuration Data > Load**.
- Restore the factory configuration (ProLink III v2.6 or later required; transmitter must be connected to an enhanced core processor). In ProLink III, select **Device Tools > Configuration Transfer > Restore Factory Configuration**.

Neither of these methods will restore all of the transmitter's configuration. For example, neither method will restore the configuration of the AI, AO, and totalizer function blocks.

Using the restore factory configuration option will also not restore such things as the configuration of the display.

4 Configuration

4.1 Overview

This chapter describes how to change the operating settings of the transmitter.

Note

All procedures provided in this chapter presume that you have established communication with the transmitter and that you are complying with all applicable requirements. Refer to [Using ProLink III with the transmitter](#) for the documentation for your PROFIBUS host or configuration tool.

4.2 Default target mode

The default target mode for all blocks is Auto. It is not necessary to set blocks to Out-of-Service (OOS) mode before changing the parameters described in this chapter.

4.3 Configuration map

Use the map in the following table to guide you through either a complete or partial configuration of the transmitter.

Table 4-1: Configuration map

Topic	Method			Section
	Display	ProLink III	EDD	
Analog input function block		✓	✓	Configuring the analog input function block channels
Totalizer block mode		✓	✓	Configuring the totalizer block mode
Gas standard volume		✓	✓	Configuring standard volume flow measurement for gas
Measurement units	✓	✓	✓	Changing the measurement units
Petroleum measurement application		✓	✓	Configuring the petroleum measurement application

Table 4-1: Configuration map (continued)

Topic	Method			Section
	Display	ProLink III	EDD	
Concentration measurement application		✓	✓	Configuring the concentration measurement application
Output scale			✓	Changing the output scale
Process alerts			✓	Changing process alerts
Alert severity		✓	✓	Configuring alert status severity
Damping		✓	✓	Changing the damping values
Two-phase-flow		✓	✓	Changing two-phase flow (slug flow) limits and duration
Cutoffs		✓	✓	Configuring cutoffs
Measurement mode		✓	✓	Changing the measurement mode parameter
Sensor parameters		✓	✓	Configuring sensor parameters
Display functionality	✓	✓	✓	Configuring the display
LD optimization	✓	✓		Enabling LD optimization
Pressure compensation	✓	✓	✓	Configuring pressure compensation
Temperature compensation	✓	✓	✓	Configuring temperature compensation

4.4 Configuring the analog input function block channels

You can set each of the transmitter's analog input (AI) function blocks to measure one transducer block channel.

About this task

The AI blocks are set at the factory to a default setting that is adequate for most applications, but you can change the assignments of the AI blocks to meet special needs.

Make sure the transducer block engineering units match the AI engineering units and the Analog Output (AO) engineering units so you do not receive a Configuration Error and so the AI block does not remain Out of Service (OOS). (Refer to [Function blocks in OOS mode](#).)

The following table shows the default channel configuration for each block.

Table 4-2: Default channel configuration

Block	Default channel	Default units
AI 1	Mass flow	g/s
AI 2	Temperature	degC
AI 3	Volume flow	l/s
AI 4	Density	g/cm ³

The following table shows the available transducer block channels.

Table 4-3: Analog Input block channel assignment options

Channel value			Process variable
Slot	Index	Value	
11 (0x0B)	17 (0x11)	0x0B11	Volume flow
11 (0x0B)	21 (0x15)	0x0B15	Mass flow
11 (0x0B)	25 (0x19)	0x0B19	Density
11 (0x0B)	29 (0x1D)	0x0B1D	Temperature
11 (0x0B)	64 (0x40)	0x0B40	Gas Standard Volume Flow
11 (0x0B)	114 (0x072)	0x0B72	Pressure
11 (0x0B)	160 (0xA0)	0x0BA0	Drive Gain
12 (0x0C)	29 (0x1D)	0x0C1D	API Corrected Density
12 (0x0C)	30 (0x1E)	0x0C1E	API Corrected Volume Flow
12 (0x0C)	31 (0x1F)	0x0C1F	API Average Corrected Density
12 (0x0C)	32 (0x20)	0x0C20	API Average Corrected Temp
12 (0x0C)	33 (0x21)	0x0C21	API CTL

Table 4-3: Analog Input block channel assignment options (continued)

Channel value			Process variable
Slot	Index	Value	
12 (0x0C)	47 (0x2F)	0x0C2F	ED Reference Density
12 (0x0C)	48 (0x30)	0x0C30	ED Specific Gravity
12 (0x0C)	49 (0x31)	0x0C31	ED Standard Volume Flow
12 (0x0C)	50 (0x32)	0x0C32	ED Net Mass Flow
12 (0x0C)	51 (0x33)	0x0C33	ED Net Volume Flow
12 (0x0C)	52 (0x34)	0x0C34	ED Concentration
12 (0x0C)	53 (0x35)	0x0C35	ED Baume

To configure the AI function block channels, use the following procedure.

Note

You must also change the Transducer block unit's code. If the two unit's codes do not match, it results in an error. For more information on modifying the Transducer block units, refer to [Configuring the totalizer block mode](#).

Note

With ProLink III there is no option to change the transducer scale engineering units, so you must use one of the other methods to make that change.

Procedure

1. Determine the method you are using to configure the AI function block channels:
 - If you are using EDD files, go to [Step 2](#).
 - If you are using bus parameters, go to [Step 4](#).
 - If you are using ProLink III, go to [Step 5](#).
 - If you are using the display, go to [Step 9](#).
2. From the EDD, choose **MMI Coriolis Flow > Function Block**.
3. For using EDD:

Option	Description
For Analog Input Block (Slots 1 through 4):	a. Select Analog Input 1...4 > General . b. Select Channel . c. Select Out Scale Units Index .
For Analog Output Block (Slots 1 and 2):	a. Analog Output 1...2 > Parameters > OutScale . b. Select Out Scale Units Index .

4. For bus parameters:

Option	Description
For Channel:	a. Select Block Analog Input Block (Slots 1, 2, 3, and 5) Index 30 (transducer block channel) .
For AI Block units:	a. Select Block Analog Input Block (Slots 1, 2, 3, and 5) Index 28, Parameter 3 (units index) .
For AO Block units	a. Select Block Analog Output Block (Slots 9 and 10) Index 27, Parameter 3 (units index) .

5. From ProLink III, select **Device Tools > Configuration > Communications > Profibus-PA**.
6. Select a channel for each AI function block.
7. Select units for each AI and AO function block.
8. Click **Apply**.
9. From the display, select **CONFIG-AI > A1 CHAN**, scroll to **AI1 Units** and modify as needed.
10. Select **AI2 CHAN**, scroll to **AI2 Units** and modify as needed.
11. Select **AI3 CHAN**, scroll to **AI3 Units** and modify as needed.
12. Select **AI4 CHAN**, scroll to **AI4 Units** and modify as needed.

4.5 Configuring the totalizer block mode

About this task

The behavior of the four totalizer function blocks can be configured in two ways:

- Standard configuration provides standard PROFIBUS totalizer function block behavior. In this mode, the totalizer block integrates the data received from the transmitter transducer block. The Out value of a totalizer in this mode will not match the totalizer data reported by the transducer block, ProLink III, or the display.
- Internal configuration modes using one of the options in the table below cause the totalizer function block to pass through the specified totalizer value from the transducer block;
Internal configuration mode is recommended for improved accuracy and to avoid mismatches between the totalizer block, ProLink, and the display.

For more information about the four totalizer function blocks, refer to [Model 2700 PROFIBUS block parameters](#).

Table 4-4: Totalizer selection options

Value	Operation mode
0	Standard (Profile Specific)
1	Internal Mass Total
2	Internal Volume Total
3	Internal Mass Inventory
4	Internal volume inventory
5	Internal GSV Total
6	Internal GSV Inventory
7	Internal API CorrVol Total
8	Internal API CorrVol Inventory
9	Internal ED_StdVolTotal
10	Internal ED_StdVolInv
11	Internal ED_NetMassTotal
12	Internal ED_NetMassInv
13	Internal ED_NetVolTotal
14	Internal ED_NetVolInv

Use the following procedure to configure the totalizer block mode:

Procedure

- Determine the method you are using to set the I/O mode:
 - If you are using the EDD, go to [Step 2](#).
 - If you are using bus parameters, go to [Step 6](#).
 - If you are using the display, go to [Figure B-9](#).
- From the EDD, choose **MMI Coriolis Flow > Function Block**.
- Depending upon which totalizer value you are modifying, select one of the following:

Option	Description
Totalizer 1	Totalizer 1 > Parameter
Totalizer 2	Totalizer 2 > Parameter
Totalizer 3	Totalizer 3 > Parameter
Totalizer 4	Totalizer 4 > Parameter

4. Go to Integration Function Block.
5. Make your selection.
6. For bus parameters, select one of the following:

Option	Description
Totalizer 1	Mode > Block: Totalizer 1 (Slot 4) Index: 52
Totalizer 2	Mode > Block: Totalizer 1 (Slot 4) Index: 52
Totalizer 3	Mode > Block: Totalizer 1 (Slot 4) Index: 52
Totalizer 4	Mode > Block: Totalizer 1 (Slot 4) Index: 52

7. Set to the mode value from [Table 4-4](#).
8. From the display, select **CONFIG TOT > TOT1 MODE > TOT1 CHAN > TOT1 Units**.
9. Repeat Step 8 for values 2 through 4 as needed.

4.6 Configuring standard volume flow measurement for gas

Two types of volume flow measurement are available:

- Liquid volume (the default)
- Gas standard volume

Only one type of volume flow measurement can be performed at a time (which means if liquid volume flow measurement is enabled, gas standard volume flow measurement is disabled). Different sets of volume flow measurement units are available, depending on which type of volume flow measurement is enabled. If you want to use a gas volume flow unit, additional configuration is required.

Note

If you use the petroleum measurement application or the concentration measurement application, liquid volume flow measurement is required.

To configure gas standard volume flow you must:

- Enable gas standard volume flow
- Specify the standard density (density at reference conditions) of your gas
- Select the measurement unit to use
- Set the low flow cutoff value

Note

The display allows you to select a volume measurement unit from the set available for the configured volume flow type, but it does not allow you to configure gas standard volume flow.

4.6.1 Enabling and configuring gas standard volume

Gas Standard Volume Flow Measurement Unit specifies the unit of measure displayed for the gas standard volume flow rate.

About this task

To enable and configure gas standard volume:

Procedure

Use the appropriate procedure in the table that follows to either enable or configure gas standard volume for your transmitter:

<p>ProLink III for enabling and configuring gas standard volume</p>	<p>Device Tools > Configuration > Process Measurement > Flow tab.</p> <ol style="list-style-type: none"> a. Set Vol Flow Type to <i>Gas Standard Volume</i>. b. Select units from the Std Gas Vol Flow Units list. c. Configure Gas Standard Volume Flow Cutoff. d. If you know the gas density, enter the density in the Standard Density of Gas box and click Apply to complete the task. e. If you do not know the gas density, access the Gas Wizard. <ol style="list-style-type: none"> 1. If the gas you are measuring is in the Choose Gas list, select it and click Next: <ul style="list-style-type: none"> • If correct, go to 1.f. • If incorrect, change the reference conditions and enter the new reference information. 2. If the gas you are measuring is not in the Choose Gas list, enter Other Gas Property. <ul style="list-style-type: none"> • Select the method from Molecular Weight, Specific Gravity Compared to Air, or Density, and the provide the required information. If you select Density, you must enter the value in the configured density units and you must provide both the temperature and the pressure at which the density value was determined. 3. Verify the revised reference temperature and pressure. f. Click Next > Finish > Apply to complete the task.
<p>Bus Parameters for enabling and configuring gas standard volume</p>	<ol style="list-style-type: none"> a. Enabling GSV: Block: Transducer Block 1 (Slot 11) Index 62 (Enable GSV) b. Configuring GSV: Block: Transducer Block 1 (Slot 11) Index 63 (Gas density) Index 67 (GSV flow units) Index 69 (GSV flow cutoff)

EDD for enabling GSV	MMI Coriolis Flow > Transducer Block > Measurement > Process Variable > Volume Flow Type a. Set the Volume Flow type to <i>STD Gas Volume</i> .
EDD for configuring GSV	MMI Coriolis Flow > Transducer Block > Measurement > Process Variable > Volume Flow a. Gas Std Density. b. Gas Std Vol Flow Units c. Gas Std Vol Flow Cutoff

4.7 Changing the measurement units

The transmitter is able to store measurement units in two different places: the transducer block and the AI block.

Both the transducer block and the AI block are independent and can be set to different values, which affects configuration in the following ways:

- If you are using a PROFIBUS configuration tool or the display, units are sent to match in both the relevant AI block and the transducer block.
- If you are using ProLink III, go to **Device Tools > Configuration > Communications > Profibus-PA** to configure units. Although units can be configured in some of the other menus, doing so may produce unintended results.

Note

Changing the measurement units for a process variable automatically changes the associated totalizer units as well. For example, setting the mass flow units to g/s automatically sets the mass totalizer unit to grams.

Note

Configure the AI block channel before configuring the AI block units. The AI blocks produce an error if the measurement units are set to a value that is impossible for the configured channel.

To configure measurement units, refer to the following tables and the procedures at the end of both [Configuring the analog input function block channels](#) and [Setting the IO mode](#).

Table 4-5: Mass flow measurement units

Mass flow unit			Unit description
EDD	ProLink III	Display	
g/s	g/s	G/S	Grams per second
g/min	g/min	G/MIN	G/MIN
g/h	g/hr	G/H	Grams per hour
kg/s	kg/s	KG/S	Kilograms per second
kg/min	kg/min	KG/MIN	Kilograms per minute

Table 4-5: Mass flow measurement units (continued)

Mass flow unit			Unit description
EDD	ProLink III	Display	
kg/h	kg/hr	KG/HR	Kilograms per hour
kg/d	kg/day	KG/D	Kilograms per day
t/min	mTon/min	T/MIN	Metric tons per minute
t/h	mTon/hr	T/H	Metric tons per hour
t/d	mTon/day	T/D	Metric tons per day
lb/s	lbs/s	LB/S	Pounds per second
lb/h	lbs/hr	LBS/H	Pounds per hour
lb/d	lbs/day	LB/D	Pounds per day
STon/min	sTon/min	ST/MIN	Short tons (2000 pounds) per minute
STon/h	sTon/hr	ST/H	Short tons (2000 pounds) per hour
STon/d	sTon/day	ST/D	Short tons (2000 pounds) per day
LTon/h	lTon/hr	LT/H	Long tons (2240 pounds) per hour
LTon/d	lTon/day	LT/D	Long tons (2204 pounds) per day

Table 4-6: Liquid flow measurement units new

Liquid flow unit			Unit description
EDD	ProLink III	Display	
CFS	ft ³ /sec	CUFT/S	Cubic feet per second
CFM	ft ³ /min	CUF/MN	Cubic feet per minute
CFH	ft ³ /hr	CUFT/H	Cubic feet per hour
ft ³ /d	ft ³ /day	CUFT/D	Cubic feet per day
m ³ /s	m ³ /sec	M ³ /S	Cubic meters per second
m ³ /min	m ³ /min	M ³ /MIN	Cubic meters per minute
m ³ /h	m ³ /hr	M ³ /H	Cubic meters per hour
m ³ /d	m ³ /day	M ³ /D	Cubic meters per day
gal/s	US gal/sec	USGPS	U.S. gallons per second
GPM	US gal/min	USGPM	U.S. gallons per minute
gal/h	US gal/hr	USGPH	U.S. gallons per hour
gal/d	US gal/d	USGPD	U.S. gallons per day

Table 4-6: Liquid flow measurement units new (continued)

Liquid flow unit			Unit description
EDD	ProLink III	Display	
Mgal/d	mil US gal/day	MILG/D	Millions of U.S. gallons per day
L/s	l/sec	L/S	Litres per second
L/min	l/min	L/MIN	Litres per minute
L/h	l/hr	L/H	Litres per hour
ML/d	mil l/day	MILL/D	Million litres per day
ImpGal/s	Imp gal/sec	UKGPS	Imperial gallons per second
ImpGal/s	Imp gal/min	UKGPM	Imperial gallons per minute
ImpGal/h	Imp gal/hr	UKGPH	Imperial gallons per hour
ImpGal/d	Imp gal/day	UKGPD	Imperial gallons per day
bbl/s	barrels/sec	BBL/S	Barrels per second ⁽¹⁾
bbl/min	barrels/min	BBL/MN	Barrels per minute ⁽¹⁾
bbl/h	barrels/hr	BBL/H	Barrels per hour ⁽¹⁾
bbl/d	barrels/day	BBL/D	Barrels per day ⁽¹⁾
bbl(fed)s	Beer barrels/sec	BBBL/S	Beer barrels per ⁽²⁾ second
bbl(fed)min	Beer barrels/min	BBBL/MN	Beer barrels per minute ⁽²⁾
bbl(fed)/h	Beer barrels/hr	BBBL/H	Beer barrels per hour ⁽²⁾
bbl(fed)/d	Beer barrels/day	BBBL/D	Beer barrels per day ⁽²⁾

(1) Unit based on oil barrels (42 U.S. gallons)

(2) Unit based on U.S. beer barrels (31 U.S. gallons)

Table 4-7: Volume flow measurement units -- Gas

Gas Volume flow unit			Unit description
EDD	ProLink III	Display	
Nm ³ /s	Nm ³ /sec	NM ³ /S	Normal cubic meters per second
Nm ³ /m	Nm ³ /min	NM ³ /MN	Normal cubic meters per minute
Nm ³ /h	Nm ³ /hr	NM ³ /H	Normal cubic meters per hour
Nm ³ /d	Nm ³ /day	NM ³ /D	Normal cubic meters per day
NL/s	NLPS	NLPS	Normal liter per second

Table 4-7: Volume flow measurement units -- Gas (continued)

Gas Volume flow unit			Unit description
EDD	ProLink III	Display	
NL/m	NLPM	NLPM	Normal liter per minute
NL/h	NLPH	NLPH	Normal liter per hour
NL/d	NLPD	NLPD	Normal liter per day
SCFS	SCFS	SCFS	Standard cubic feet per second
SCFM	SCFM	SCFM	Standard cubic feet per minute
SCFH	SCFH	SCFH	Standard cubic feet per hour
SCFD	SCFD	SCFD	Standard cubic feet per day
Sm ³ /s	Sm ³ /S	SM ³ /S	Standard cubic meters per second
Sm ³ /m	Sm ³ /min	SM ³ /MN	Standard cubic meters per minute
Sm ³ /h	Sm ³ /hr	SM ³ /H	Standard cubic meters per hour
Sm ³ /d	Sm ³ /day	SM ³ /D	Standard cubic meters per day
SL/s	SLPS	SLPS	Standard liter per second
SL/m	SLPM	SLPM	Standard liter per minute
SL/h	SLPH	SLPH	Standard liter per hour
SL/d	SLPD	SLPD	Standard liter per day

Table 4-8: Density measurement units

Density unit			Unit description
EDD	ProLink III	Display	
g/cm ³	g/cm ³	G/CM ³	Grams per cubic centimeter
g/L	g/l	G/L	Grams per liter
g/ml	g/ml	G/ML	Grams per milliliter
kg/L	kg/l	KG/L	Kilograms per liter
kg/m ³	kg/m ³	KG/M ³	Kilograms per cubic meter
lb/gal	lbs/USgal	LB/GAL	Pounds per U.S. gallon
lb/ft ³	lbs/ft ³	LB/CUF	Pounds per cubic foot
lb/in ³	lbs/in ³	LB/CUI	Pounds per cubic inch
STon/yd ³	sT/yd ³	ST/CUY	Short ton per cubic yard

Table 4-8: Density measurement units (continued)

Density unit			Unit description
EDD	ProLink III	Display	
degAPI	degAPI	D API	Degrees API
SGU	SGU	SGU	Specific gravity unit (based on Water at 60 degF)

Table 4-9: Temperature measurement units

Temperature unit			Unit description
EDD	ProLink III	Display	
°C	°C	°C	Degrees Celsius
°F	°F	°F	Degrees Fahrenheit
°R	°R	°R	Degrees Rankine
°K	°K	°K	Degrees Kelvin

Table 4-10: Pressure measurement units

Pressure unit			Unit description
EDD	ProLink III	Display	
In ft H2O @ 68 DegF	In Water @ 68 °F	FTH2O	Feet Water @ 68 °F
In ft H2O @ 4 DegC	In Water @ 4 °C	INW4cH2O	Inches Water @ 4 °C
In inch H2O @ 68 DegF	In Water @ 68 °F	INH2O	Inches Water @ 68 °F
mm H2O @ 4 DegC	mm Water @ 4 °C	mmW4C	Millimeters Water @ 4 °C
mm H2O @ 68DegFC	mm Water @ 68 °F	mmH2O	Millimeters Water @ 68 °F
inch Hg @ 0DegC	In Mercury @ 0 °C	INHG	Inches mercury @ 0 °C
mm Hg @ 0DegC	mm Mercury @ 0 °C	mmHG	Millimeters mercury @ 0 °C
psi	PSI	PSI	Pounds per square inch
bar	bar	BAR	Bar
millibar	millibar	mBAR	Millibar
g_per_cm2	g/cm2	G/SCM	Grams per square centimeter
kg_per_cm2	kg/cm2	KG/SCM	Kilograms per square centimeter
pa	pascals	PA	Pascals
MegaPa	megapascals	MPA	Megapascals
KiloPa	Kilopascals	KPA	Kilopascals
torr @0 DegC	Torr @ 0C	TORR	Torr @ 0 °C

Table 4-10: Pressure measurement units (continued)

Pressure unit			Unit description
EDD	ProLink III	Display	
atm	atms	ATM	Atmospheres

4.8 Configuring the petroleum measurement application

The petroleum measurement parameters determine the values that are used in petroleum measurement-related calculations. The petroleum measurement parameters are available only if the petroleum measurement application is enabled on your transmitter.

Note

The petroleum measurement application requires liquid volume measurement units. If you plan to use petroleum measurement process variables, ensure that liquid volume flow measurement is specified. Refer to [Enabling and configuring gas standard volume](#).

4.8.1 About the petroleum measurement application

Some applications that measure liquid volume flow or liquid density are particularly sensitive to temperature factors, and must comply with American Petroleum Institute (API) standards for measurement. The petroleum measurement application enables Correction of Temperature on volume of Liquids (CTL).

Terms and definitions

The following terms and definitions are relevant to the petroleum measurement application:

- API -- American Petroleum Institute
- CTL -- Correction of Temperature on volume of Liquids: The CTL value is used to calculate the VCF value.
- TEC -- Thermal Expansion Coefficient
- VCF -- Volume Correction Factor: The correction factor to be applied to volume process variables. VCF can be calculated after CTL is derived.

CTL derivation methods

There are two types of derivation methods for CTL:

- Method 1 is based on observed density and observed temperature.
- Method 2 is based on a user-supplied reference density (or thermal expansion coefficient, in some cases) and observed temperature.

Petroleum measurement reference tables

Reference tables are organized by reference temperature, CTL derivation method, liquid type, and density unit. The table selected here controls all the remaining options.

- Reference temperature:

- If you specify a 5x, 6x, 23x, or 24x table, the default reference temperature is 60 °F, and cannot be changed.
- If you specify a 53x or 54x table, the default reference temperature is 15 °C; however, you can change the reference temperature, as recommended in some locations (for example, to 14.0 or 14.5 °C).
- CTL derivation method:
 - If you specify an odd-numbered table (5, 23, or 53), CTL is derived using method 1 described above.
 - If you specify an even-numbered table (6, 24, or 54), CTL is derived using method 2 described above.
- The letters A, B, C, or D that are used to terminate table names define the type of liquid that the table is designed for:
 - A tables are used with generalized crude and JP4 applications.
 - B tables are used with generalized products.
 - C tables are used with liquids with a constant base density or known thermal expansion coefficient.
 - D tables are used with lubricating oils.
- Different tables use different density units:
 - Degrees API
 - Relative density (SG)
 - Base density (kg/m³)

The following tables summarize the options cited above. For Density unit and range, use one of the last three columns (Degrees API, Base density, or Relative density).

Table 4-11: Petroleum measurement method 1 reference temperature tables

Table	Base temperature	Degrees API	Base density	Relative density
5A	60 °F, non-configurable	0 to +100		
5B	60 °F, non-configurable	0 to +85		
5D	60 °F, non-configurable	0 to +85		
23A	60 °F, non-configurable			0.6110 to 1.0760
23B	60 °F, non-configurable			0.6535 to 1.0760
23D	60 °F, non-configurable			0.8520 to 1.1640
53A	15 °C, configurable		610 to 1075 kg/m ³	
53B	15 °C, configurable		653 to 1075 kg/m ³	
53D	15 °C, configurable		825 to 1164 kg/m ³	

Table 4-12: Petroleum measurement method 2 reference temperature tables

Table	Base temperature	Reference temperature	Supports
6C	60 °F, non-configurable	60 °F	Degrees API

Table 4-12: Petroleum measurement method 2 reference temperature tables (continued)

Table	Base temperature	Reference temperature	Supports
24C	60 °F, non-configurable	60 °F	Relative density
54C	15 °C, configurable	15 °C	Base density in kg/m ³

4.8.2 Configuring for petroleum measurement

About this task

The petroleum measurement configuration parameters allow you to set a table type and set a user-defined thermal expansion coefficient (TEC).

Table 4-13 lists and defines the petroleum measurement configuration parameters you can modify to perform these configuration tasks. For the petroleum measurement values, refer to Table F-44.

Table 4-13: Petroleum measurement parameters

Variable	Description
Table type	Specifies the table that is used for reference temperature and reference density unit. Select the table that matches your requirements. Refer to the petroleum measurement reference tables. (check on this reference).
User defined TEC ⁽¹⁾	Thermal expansion coefficient. Enter the value to be used in CTL calculation.
Temperature units ⁽²⁾	Read-only. Displays the unit used for reference temperature in the reference table.
Density units	Read-only. Displays the unit used for reference density in the reference table.
Reference temperature	Read-only unless Table Type is set to 53x or 54x. If configurable: <ul style="list-style-type: none"> Specify the reference temperature to be used in CTL calculation. Enter reference temperature in °C.

(1) Configurable if Table Type is set to 6C, 24C, or 54C.

(2) In most cases, the temperature unit used by the petroleum measurement reference table should also be the temperature unit configured for the transmitter to use in general processing. To configure the temperature unit, refer to [Changing the measurement units](#).

Procedure

Use the following procedure to set the petroleum measurement table type and set a user-defined TEC, using your communication tool of choice.

ProLink III for setting the petroleum measurement table type	<p>Device Tools > Configuration > Process Measurement > Petroleum Measurement tab.</p> <ol style="list-style-type: none"> Select the table type value from the API Table Type list. Click Apply to complete the task.
Bus Parameters for setting the petroleum measurement table type	<ol style="list-style-type: none"> Table type: (Block: Transducer Block 2 (Slot 12) Index 40 (APIU2540) CTL table type)
EDD for setting the petroleum measurement table type	<p>MMI Coriolis Flow > Transducer Block > API</p> <ol style="list-style-type: none"> Specify the <i>API2540 CTL Table Type</i>.
ProLink III for setting a user-defined TEC	<p>Device Tools > Configuration > Process Measurement > Petroleum Measurement tab.</p> <ol style="list-style-type: none"> Enter a coefficient in the User defined TEC box. Click Apply to complete the task.
Bus Parameters for setting a user-defined TEC	<ol style="list-style-type: none"> TEC: (Block: Transducer Block 2 (Slot 12) Index 39 (API thermal expansion coeff.))
EDD for setting a user-defined TEC	<p>MMI Coriolis Flow > Transducer Block > API</p> <ol style="list-style-type: none"> Specify the <i>API Thermal Expansion Coeff.</i>

4.9 Configuring the concentration measurement application

Micro Motion® sensors provide direct measurements of density, but not of concentration. The concentration measurement application calculates process variables such as concentration or density at reference temperature, using density process data appropriately corrected for temperature.

Note

For a detailed description of the concentration measurement application, see the *Micro Motion® Enhanced Density Application: Theory, Configuration, and Use*.

Note

The concentration measurement application requires liquid volume measurement units. If you plan to use concentration measurement process variables, ensure the liquid volume flow measurement is specified. Refer to [Configuring standard volume flow measurement for gas](#).

4.9.1 About the concentration measurement application

The concentration measurement calculation requires a concentration measurement curve, which specifies the relationship between temperature, concentration, and density for the process fluid being measured. Micro Motion supplies a set of six standard concentration measurement curves (refer to the following table). If none of these curves is appropriate for your process fluid, you can configure a custom curve or purchase a custom curve from Micro Motion.

The derived variable, specified during configuration, controls the type of concentration measurement that will be produced. Each derived variable allows the calculation of a subset of concentration measurement process variables (see the table below). The available concentration measurement process variables can be used in process control, just as mass flow rate, volume flow rate, and other process variables are used. For example, an event can be defined on a concentration measurement process variable.

- For all standard curves, the derived variable is Mass Conc (Dens).
- For custom curves, the derived variable can be any of the variables listed in the following table.

The transmitter can hold up to six curves at any given time, but only one curve can be active (used for measurement) at a time. All curves that are in transmitter memory must use the same derived value.

Table 4-14: Standard curves and associated measurement units

Name	Description	Density unit	Temperature Unit
Deg Balling	Curve represents percent extract, by mass, in solutions based on "Balling". For example, if a wort is 10 °Balling and the extract in solution is 100% sucrose, the extract is 10% of the total mass.	g/cm ³	°F
Deg Brix	Curve represents a hydrometer scale for sucrose solutions that indicates the percent by mass of sucrose in solution at a given temperature. For example, 40 kg of sucrose mixed with 60 kg of water results in a 40° Brix solution.	g/cm ³	°C
Deg Plato	Curve represents percent extract, by mass, in solution, based on °Plato. For example, if a wort is 10° Plato and the extract in solution is 100% sucrose, the extract is 10% of the total mass.	g/cm ³	°F

Table 4-14: Standard curves and associated measurement units (continued)

Name	Description	Density unit	Temperature Unit
HFCS 42	Curve represents a hydrometer scale for HFCS42 (high fructose corn syrup) solutions that indicates the percent by mass of HFCS in solution.	g/cm ³	°C
HFCS 55	Curve represents a hydrometer scale for HFCS55 (high fructose corn syrup) solutions that indicates the percent by mass of HFCS in solution.	g/cm ³	°C
HFCS 90	Curve represents a hydrometer scale for HFCS90 (high fructose corn syrup) solutions that indicates the percent by mass of HFCS in solution.	g/cm ³	°C

4.9.2 Configuring for concentration measurement

About this task

Complete configuration instructions for the concentration measurement application are provided in the *Micro Motion Enhanced Density Application: Theory, Configuration, and Use manual*.

Note

The concentration measurement manual uses Pro Link III as the standard configuration tool for the concentration measurement application. Because the PROFIBUS parameters are very similar to the Pro Link III labels, you can follow the instructions for Pro Link III and adapt them to your host. All of the parameters related to the concentration measurement application can be found in Transducer Block 2 (Slot 12). Refer to [Table F-48](#).

The typical configuration procedure simply sets up the concentration measurement application to use a standard curve. The following steps are required:

Procedure

1. Set the transmitter's density measurement unit to match the unit used by the curve (as listed in [Table 4-14](#)).
2. Set the transmitter's temperature measurement unit to match the unit used by the curve (as listed in [Table 4-14](#)).
3. Set the derived variable to Mass Conc (Dens).
4. Specify the active curve.

4.10 Changing the output scale

About this task

Because Coriolis meters publish the process variable in engineering units, there is no need to scale a Coriolis meter's output.

The AI function blocks can be configured to scale their output. The output scale is established by defining a process variable value at 0% of scale and at 100% of scale. The output of the AI block will be translated to a value between these two limits. To see the AI function block layout, refer to [Analog Input \(AI\) function block parameters](#).

If you choose to use output scaling, note that it has no effect on the process values found in the transducer block. This results in the following behaviors:

- ProLink III and the display use the process values in the transducer block. Therefore, the output of a scaled AI block may differ from the value reported by other communication tools.
- Two-phase and flow cutoffs are configured in the transducer block. Therefore, output scaling has no effect on the behavior of the transmitter with regard to two-phase or flow cutoffs.

Note

When Coriolis meters require no scaling, make sure the **Out_Scale** and **PV_Scale** parameters have the same settings.

Procedure

Use the following procedure to change the output scale, using your communication tool of choice.

<p>Bus Parameters for changing the output scale</p>	<p>a. Output Scale:</p> <p>Block: Analog Input Block</p> <p>Slot (1, 2, 3, and 5)</p> <p>Index 28, (Parameter1 (EU100))</p> <p>Index 28, (Parameter2 (EU0))</p>
<p>EDD for changing the output scale</p>	<p>a. MMI Coriolis Flow > Function Block > Analog Input1 ...4 > Parameters > OutScale</p> <p>b. Out Scale EU0</p> <p>c. Out Scale EU100</p> <p>MMI Coriolis Flow > Function Block > Analog Input1 ...4 > Parameters > OutScale > Out Scale EU0 > Out Scale EU100</p>

4.11 Changing process alerts

The transmitter uses process alerts to indicate that a process value has exceeded its user-defined limits. The transmitter maintains four alert values for each process variable. In addition, the transmitter has an alert hysteresis function to prevent erratic alert reports.

Note

Process alerts are only posted through the AI function blocks (refer to [Analog Input \(AI\) function block parameters](#)) and totalizer blocks (refer to [Totalizer block parameters](#)) and are not shown on the display or in ProLink III.

4.11.1 Changing alert values

About this task

The process alert values are the limits for process variables. Whenever a process variable exceeds a process alert value, the alert will be reflected in the “Alert Summary” parameter in each block.

Each AI function block and totalizer block has four process alert limits: high alert, high-high alert, low alert, and low-low alert. See the following figure. The high and low process alert values represent normal process limits. The high-high and low-low process alert values are used for more complex alert signals to indicate a more severe problem than a regular process alert indicates.

Figure 4-1: Alert values

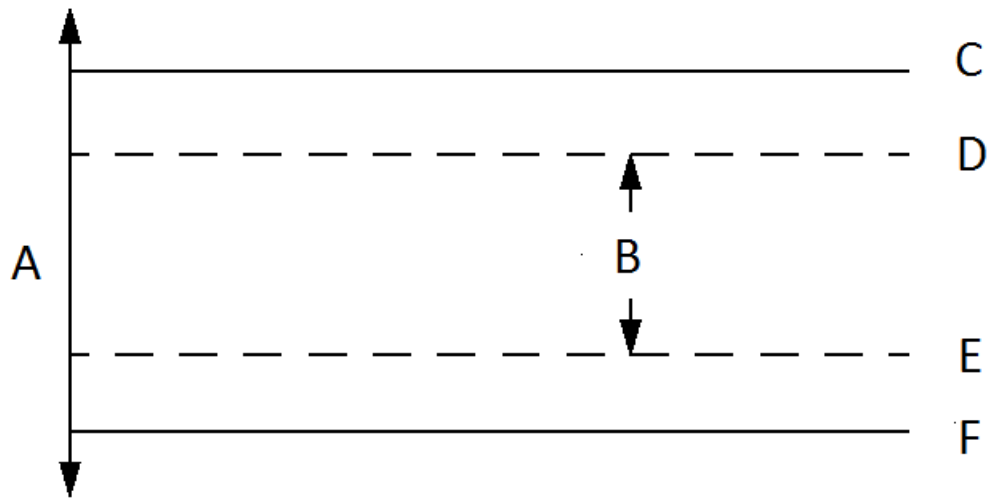

- A. Process variable
- B. Normal process range
- C. High-high alert
- D. High alert
- E. Low alert
- F. Low-low alert

Procedure

Use the following procedure to change the alert values, using your communication tool of choice.

<p>Bus Parameters for changing the alert values</p>	<p>a. AI block limits:</p> <p>Block: Analog Input Block (Slot 1, 2, 3, and 5)</p> <p>Index 37 (Hi Hi Limit)</p> <p>Index 39 (Hi Limit)</p> <p>Index 41 (Lo Limit)</p> <p>Index 43 (Lo Lo Limit))</p> <p>b. Totalizer block limits:</p> <p>Block: Totalizer Block (Slots 4, 6, 7, and 8)</p> <p>Index 34 (Hi Hi Limit)</p> <p>Index 35 (Hi Limit)</p> <p>Index 36 (Lo Limit)</p> <p>Index 37 (Lo Lo Limit))</p>
<p>EDD for changing the output scale</p>	<p>a. To use analog input:</p> <ol style="list-style-type: none"> 1. MMI Coriolis Flow > Function Block > Analog Input1 ...4 > Parameters 2. Limits > Hi-Lim > Hi-Hi Lim > Lo Lim > Lo Lo Lim <p>a. To use the totalizer:</p> <ol style="list-style-type: none"> 1. MMI Coriolis Flow > Function Block > Totalizer 1...4 > Parameter 2. Limit > Hi-Lim > Hi-Hi Lim > Lo Lim > Lo Lo Lim

4.11.2 Changing alert hysteresis

About this task

The alert hysteresis value is a percentage of the output scale. After a process alert is created, the transmitter will not create new alerts unless the process first returns to a value within the range of the alert hysteresis percentage. The following figure shows the transmitter's alert behavior with an alert hysteresis value of 50%.

Note the following about hysteresis:

- A low hysteresis value allows the transmitter to broadcast a new alert every time or nearly every time the process variable crosses over the alert limit.
- A high hysteresis value prevents the transmitter from broadcasting new alerts unless the process variable first returns to a value sufficiently below the high alert limit or above the low alert limit.

Figure 4-2: High versus low alert hysteresis values

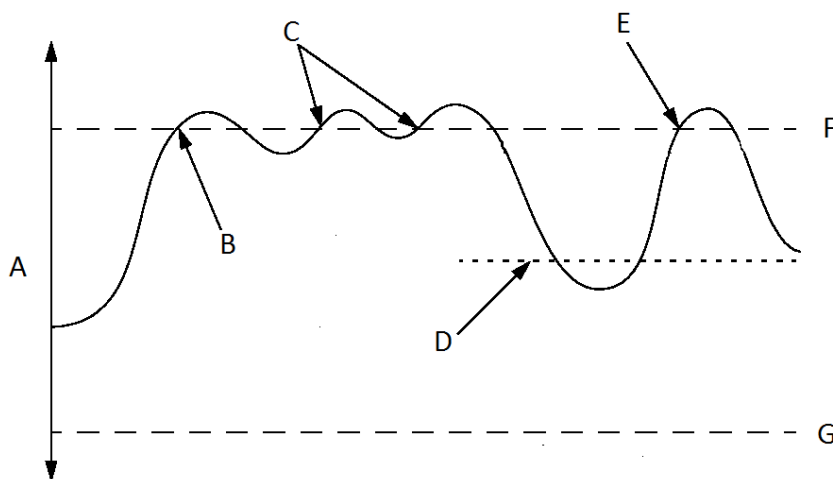

- A. Process variable
- B. Alert created
- C. New alerts not created
- D. Hysteresis value
- E. New alert created here
- F. High alert
- G. Low alert

Bus Parameters for changing the alert values	1. Hysteresis: Block: Analog Input Block (Slots 1, 2, 3, and 5) Index 37 (Hysteresis)
EDD for changing the output scale	1. MMI Coriolis Flow > Function Block > Analog Input1 ...4 > Parameters 2. Limits > Alert Hys

4.12 Configuring alert status severity

About this task

The severity level of some status alerts can be reclassified. For example

- The default severity level for Alert A020 (calibration factors unentered) is Fault, but you can reconfigure it to either Informational or Ignore.
- The default severity level for Alert A102 (drive over-range) is Informational, but you can reconfigure it to either Ignore or Fault.

A list of all status alerts and default severity levels is shown in the table below (For more information on status alerts, including possible causes and troubleshooting suggestions, see [Status alerts](#)).

Table 4-15: Status alerts and security levels

Alert code	Index	Description	Default severity	Configurable
A001	1	EEPROM checksum	Fault	No
A002	2	RAM error	Fault	No
A003	3	Sensor failure	Fault	Yes
A004	4	Temperature sensor failure	Fault	No
A005	5	Input overrange	Fault	Yes
A006	6	Transmitter not configured	Fault	Yes
A008	8	Density overrange	Fault	Yes
A009	9	Transmitter initializing/warming up	Ignore	Yes
A010	10	Calibration failure	Fault	No
A011	11	Calibration too low	Fault	Yes
A012	12	Calibration too high	Fault	Yes
A013	13	Zero too noisy	Fault	Yes
A014	14	Transmitter failed	Fault	No
A016	16	Line temperature out-of-range	Fault	Yes
A017	17	Meter RTD temperature out-of-range	Fault	Yes
A018	18	EEPROM Error (Transmitter)	Fault	No
A020	20	Calibration factors unentered	Fault	Yes
A021	21	Incorrect sensor type	Fault	No
A022	22	Configuration corrupt	Fault	Yes
A023	23	Totals corrupt	Fault	Yes
A024	24	CP program corrupt	Fault	Yes
A025	25	Boot sector fault	Fault	Yes

Table 4-15: Status alerts and security levels (continued)

Alert code	Index	Description	Default severity	Configurable
A026	26	Sensor/Transmitter communications failure	Fault	No
A028	28	Sensor/Transmitter write failure	Fault	No
A030	30	Hardware/software incompatible	Fault	Yes
A031	31	Low power	Informational	No
A032	32	Smart Meter Verification in progress and outputs fixed	Fault	Yes
A033	33	Tube Not Full	Fault	Yes
A034	34	Smart Meter Verification failed	Informational	Yes
A035	35	Smart Meter Verification aborted	Informational	Yes
A102	42	Drive overrange	Informational	Yes
A103	43	Data loss possible	Informational	Yes
A104	44	Calibration in progress	Informational	Yes
A105	35	Two-phase flow (Slug flow)	Informational	Yes
A106	35	Function block simulate	Informational	Yes
A107	47	Power reset occurred	Informational	Yes
A116	35	Power reset occurred	Informational	Yes
A117	57	API temperature outside standard range	Informational	Yes
A120	60	Concentration measurement: unable to fit curve data	Informational	No
A121	61	Concentration measurement: extrapolation alert	Informational	Yes
A131	71	Smart Meter Verification in progress	Informational	Yes

Table 4-15: Status alerts and security levels (continued)

Alert code	Index	Description	Default severity	Configurable
A132	72	Simulation mode active	Informational	Yes

ProLink III for configuring status alert severity	<ol style="list-style-type: none"> 1. Device Tools > Configuration 2. Select the Alert Severity tab. 3. Select an alert from the Alert Name list. 4. Select a severity from the Alert Severity list. 5. Click Apply.
Bus Parameters for configuring status alert severity	<ol style="list-style-type: none"> 1. Select alert: Block Transducer: Block 1 (Slot 11) Index 149 (Alert index) 2. Select severity: Block Transducer: Block 1 (Slot 11) Index 150 (Alert severity)
EDD for configuring status alert severity	<ol style="list-style-type: none"> 1. MMI Coriolis Flow > Transducer Block > Alert > Alert Status Parameter 2. Select alert from Alert Index. 3. Select severity from Alert Severity.

4.13 Changing the damping values

About this task

A damping value is a period of time, in seconds, over which the process variable value will change to reflect 63% of the change in the actual process. Damping helps the transmitter smooth out small, rapid measurement fluctuations.

- A high damping value makes the output appear to be smoother because the output must change slowly.
- A low damping value makes the output appear to be more erratic because the output changes more quickly.

Note

There is also a “damping” parameter in each AI block called AI PV Filter Time (index 32). In order to avoid having two (potentially conflicting) damping values, you should set

damping values only in the transducer block. The AI PV Filter Time parameter for each AI block should be set to 0.

When you specify a new damping value, it is automatically rounded down to the nearest valid damping value. Valid damping values are listed in the following table.

Table 4-16: Valid damping values

Process variable	Initial values	Valid damping values
Flow (mass and volume)	0.80000	0, 0.04, 0.08, 0.16, ... 40.96
Density	1.60000	0, 0.04, .0.08, 0.16, ... 40.96
Temperature	4.80000	0, 0.6, 1.2, 2.4, 4.8, ...76.8

ProLink III path for changing damping values	<ol style="list-style-type: none"> 1. Device Tools > Configuration > Process Measurement 2. Select Flow tab and enter a damping value in the Flow Rate Damping box, then click Apply. 3. Select Density tab and enter a damping value in the Density Damping box, then click Apply. 4. Select Temperature tab and enter a damping value in the Temperature Damping box, then click Apply.
Bus Parameters for changing damping values	<ol style="list-style-type: none"> 1. Damping: <ul style="list-style-type: none"> Block Transformation: Block 1 (Slot 11) Index 33 (flow damping) Index 34 (temperature damping) Index 35 (density damping)
EDD for changing damping values	<ol style="list-style-type: none"> 1. MMI Coriolis Flow > Transducer Block > Measurement > Process Variable 2. Select Mass Flow > Flow Damping. 3. Select Temperature > Temperature Damping. 4. Select Density > Density Damping.

4.13.1 Damping and volume measurement

When configuring damping values:

- Liquid volume flow is derived from mass and density measurements. Therefore, any damping applied to mass flow and density will affect liquid volume measurement.
- Gas standard volume flow is derived from mass flow measurement, but not from density measurement. Therefore, only damping applied to mass flow will affect gas standard volume measurement.

Note

Be sure to set damping values accordingly.

4.14 Changing two-phase flow (slug flow) limits and duration

About this task

Slugs—gas in a liquid process or liquid in a gas process—occasionally appear in some applications. The presence of slugs can significantly affect the process density reading. The two-phase flow parameters can help the transmitter suppress extreme changes in process variables, and can also be used to identify process conditions that require correction.

Two-phase flow parameters are as follows:

- *Two-Phase Flow Low Limit* — the point below which a condition of two-phase flow will exist. Typically, this is the lowest density you expect to observe for your process. The default value is 0.0g/cm³. The valid range is 0.0–10.0g/cm³.
- *Two-Phase Flow High Limit* — the point above which a condition of two-phase flow will exist. Typically, this is the highest density you expect to observe for your process. The default value is 5.0g/cm³. The valid range is 0.0–10.0 g/cm³.
- *Two-Phase Flow duration* — the number of seconds the transmitter waits for a two-phase flow condition to clear. If the transmitter detects two-phase flow, it will post a two-phase flow alert and hold its last “pre-two-phase” flow rate until the end of the two-phase flow duration and the measurement quality will be marked “uncertain.” If two-phase flow is still present after the two-phase flow duration has expired, the transmitter will report a flow rate of zero (the measurement quality will remain at “uncertain”). The default value for two-phase flow duration is 0.0 seconds. The valid range is 0.0–60.0seconds.

Note

The two-phase flow limits must be entered in g/cm³, even if another unit has been configured for density. Two-phase flow duration is entered in seconds. Raising the Two-Phase Flow Low Limit or lowering the Two-Phase Flow High Limit will increase the possibility of detecting two-phase flow conditions. Conversely, lowering the Two-Phase Flow Low Limit or raising the Two-Phase Flow High Limit will decrease the possibility of detecting two-phase flow conditions. If two-phase flow duration is set to 0, the mass flow rate will be forced to 0 as soon as two-phase flow is detected.

A list of all status alerts and default severity levels is shown in [Configuring alert status severity](#). (For more information on status alerts, including possible causes and troubleshooting suggestions, see [Status alerts](#).)

ProLink III path for changing damping values	<ol style="list-style-type: none"> 1. Device Tools > Configuration > Process Measurement 2. Select Density tab and set the density limits for Two-Phase Flow Low Limit and Two-Phase Flow High Limit. 3. Set the two-phase flow duration in the Two-Phase Flow Timeout box. 4. Click Apply.
--	---

Bus Parameters for changing damping values	1. two-phase flow: Block Transformation: Block 1 (Slot 11) Index 130 (duration) Index 131 (low limit) Index 132 (high limit)
EDD for changing damping values	1. MMI Coriolis Flow > Transducer Block > Calibration > Slug Limit 2. Select Two Phase Hold last measured value time. 3. Select Two Phase Density Low Limit. 4. Select Two Phase Density High Limit.

4.15 Configuring cutoffs

About this task

Cutoffs are user-defined values below which the transmitter reports a value of zero for the specified process variable. Cutoffs can be configured for either mass flow, volume flow, or density.

The following table lists the default values and relevant comments for each cutoff. Note that the mass flow cutoff is not applied to the volume flow calculation. Even if the mass flow drops below the cutoff, and therefore the mass flow indicators go to zero, the volume flow rate will be calculated from the actual mass flow process variable.

Table 4-17: Valid damping values

Cutoff	Default values	Comments
Mass	0.065% of maximum flow rate of the sensor	Micro Motion recommends a mass flow cutoff value of 0.5% of the sensor's maximum flow rate for standard operation, and 2.5% of the sensor's maximum flow rate for empty-full-empty batching.
Liquid volume	0.065% of maximum flow rate of sensor	The lower limit for volume flow cutoff is 0. The upper limit for volume flow cutoff is the sensor's flow calibration factor, in L/s, multiplied by 0.2.
Density	0.2 g/cm ³	The range for density cutoff is 0.0--0.5 g/cm ³ .

<p>ProLink III path for configuring cutoff values</p>	<ol style="list-style-type: none"> 1. Device Tools > Configuration > Process Measurement: <ol style="list-style-type: none"> a. Select Density tab and enter a value in the Density Cutoff box. b. Click Apply. 2. Select Density tab and enter a value in the Density Cutoff box. 3. Go back to ProLink > Configuration. <ol style="list-style-type: none"> a. Select Density tab and enter a value in the Density Cutoff box b. Click Apply.
<p>Bus Parameters for configuring cutoff values</p>	<ol style="list-style-type: none"> 1. Cutoffs: <ul style="list-style-type: none"> Block Transducer: Block 1 (Slot 11) Index 9 (Mass Flow Cutoff) Index 39 (Liquid volume flow cutoff) Index 40 (Density cutoff) Index 69 (Gas standard volume flow cutoff)
<p>EDD for configuring cutoff values</p>	<ol style="list-style-type: none"> 1. MMI Coriolis Flow > Transducer Block > Measurement > Process Variable 2. Select Mass Flow and fill in Mass Flow Low Cutoff. 3. Select Volume Flow and fill in Volume Flow Low Cutoff. 4. Select Density and fill in Density Cutoff.

4.16 Changing the measurement mode parameter

About this task

The measurement mode parameter defines how the flow is added to or subtracted from the totalizers.

- *Forward flow* moves in the direction of the arrow on the sensor.
- *Reverse flow* moves in the direction opposite from the arrow on the sensor.

The following table shows the possible values for the measurement mode parameter and the transmitter's behavior when the flow is positive or negative. Only the unidirectional and bidirectional values are recognized by the PROFIBUS specification, so other values will be unrecognized by a PROFIBUS host or configuration tool. However, the transmitter will operate correctly in any of the modes listed in the table below.

Table 4-18: Totalizer behavior for each measurement mode value

Measurement mode value	Bus index	Forward flow	Reverse flow
Unidirectional (forward only)	0	Increase	No change
Reverse only	1	No change	Increase
Bidirectional	2	Increase	Decrease
Absolute value	3	Increase	Increase
Negate/forward only	4	No change	Increase
Negate/bidirectional	5	Decrease	Increase

ProLink III path for changing the measurement mode parameter	<ol style="list-style-type: none"> 1. Device Tools > Configuration > Process Measurement > Flow tab 2. Select a value from the Flow Direction list. 3. Click Apply.
Bus Parameters for changing the measurement mode parameter	<ol style="list-style-type: none"> 1. Measurement Mode: Block Transducer: Block 1 (Slot 11) Index 10 (measurement mode)
EDD for changing the measurement mode parameter	<ol style="list-style-type: none"> 1. MMI Coriolis Flow > Transducer Block > Measurement > Process Variable 2. Select Mass Flow and fill in Measurement Mode.

4.17 Configuring sensor parameters

About this task

The sensor parameters are used to describe the sensor component of your flow meter. These sensor parameters are not used in transmitter processing, and are not required:

- Serial number
- Sensor material
- Liner material
- Flange

<p>ProLink III path for changing the sensor parameters</p>	<ol style="list-style-type: none"> 1. Device Tools > Configuration > Informational Parameters > Sensor tab 2. Enter the sensor serial number in the Sensor s/n box. 3. Enter the sensor serial material from the Sensor Matl list. 4. Select the liner material from the Liner Matl list. 5. Select the flange from the Flange list. 6. Click Apply.
<p>Bus Parameters for changing the sensor parameters</p>	<ol style="list-style-type: none"> 1. Sensor parameters: Block Transducer: Block 2 (Slot 12) Index 10 (sensor serial number) Index 13 (sensor material) Index 14 (liner material) Index 15 (flange type)
<p>EDD for changing the sensor parameters</p>	<ol style="list-style-type: none"> 1. MMI Coriolis Flow > Transducer Block > Device Information 2. Select Sensor Serial Number. 3. Select Sensor Material. 4. Select Liner Material. 5. Select Flange Type.

4.18 Configuring the display

About this task

You can restrict the display functionality or change the variables that are shown on the display.

Each display function and its associated parameter are listed in the table below.

Table 4-19: Display functions and parameters

Display functions	EDD name	Display code	Enabled	Disabled
Totalizer reset	Totalizer Reset	TOTALS RESET	Resetting mass and volume totalizers is permitted	Resetting mass and volume totalizers is not possible
Start/stop totalizers	Start/Stop Totalizer	TOTALS STOP	Operators can start and stop totalizers from the display.	Operators cannot start or stop totalizers from the display.

Table 4-19: Display functions and parameters (continued)

Display functions	EDD name	Display code	Enabled	Disabled
Auto scroll If enabled, you may want to configure the Scroll Rate. Refer to Guidelines for setting the scroll rate.	Auto Scroll	AUTO SCROLL	The display automatically scrolls through each process variable.	Operators must use the Scroll function to view process variables.
Off-line menu	Offline Menu	DISPLAY OFFLN	Operators have access to the off-line menu.	Operators must use the Scroll function to view process variables.
Off-line password If enabled, the display offline password must also be configured. Refer to Guidelines for setting the off-line password.	Offline Password	OFFLINE PASSW	A password is required for the offline menu.	The offline menu is accessible without a password.
Alert menu	Alert Menu	DISPLAY ALERT	Operators have access to the alert menu.	No access to the alert menu.
Acknowledge all alerts	ACK All Alerts	DISPLAY ACK	Operators can acknowledge all current alerts at once.	alerts must be acknowledged individually.
Display backlight	Backlight	DISPLAY BKLT	Display backlight is ON.	Display backlight is OFF.

Note

If you use the display to disable access to the off-line menu, the off-line menu will disappear as soon as you exit the menu system. If you want to re-enable access, you must use a different method (such as, ProLink III).

Note

If you are using the display to configure the display:

- You must enable Auto Scroll before you can configure the Scroll Rate.
- You must enable the off-line password before you can configure the password.

<p>Display path for configuring the display parameters</p>	<ol style="list-style-type: none">1. Device Tools > Configuration > Transmitter Display > General tab.2. Modify Display Option, Backlight, and Scroll Option as needed.3. Click Apply.4. To modify security settings, go to Device Tools > Configuration > Transmitter Display > Display Security tab.5. Modify options as needed.6. Click Apply.7. To modify display variables, go to Device Tools > Configuration > Transmitter Display > Display Variables tab8. Modify options as needed.9. Click Apply.10. To acknowledge all alerts, go to Device Tools > Configuration > Transmitter Display > Ack All tab.11. Select <i>Enabled</i> for Acknowledge All Alerts (Ack All) from Display.12. Click Apply.
--	---

<p>Bus Parameters for changing the display parameters</p>	<p>1. Display options:</p> <p>Block Transducer: Block 1 (Slot 11)</p> <p>Index 220 (Totalizer reset)</p> <p>Index 221 (Totalizer start/stop)</p> <p>Index 222 (Auto Scroll enabled/disabled)</p> <p>Index 223 (Offline menu enabled/disabled)</p> <p>Index 224 (Offline password enabled/disabled)</p> <p>Index 225 (Alert menu enabled/disabled)</p> <p>Index 226 (Acknowledge all alerts)</p> <p>Index 227 (Set offline password)</p> <p>Index 228 (Auto scroll period)</p> <p>Index 229 (Display backlight)</p> <p>Index 247 (Update period)</p>
<p>EDD for changing the display parameters</p>	<p>1. MMI Coriolis Flow > Transducer Block > Display Configuration</p> <p>a. Select Display Option.</p> <ul style="list-style-type: none"> • Totalizer Reset • Start/Stop Totals • Offline Menu • Alert Menu • ACK all alerts • Offline password • Auto Scroll • Scroll Period • Language <p>b. Select Display Parameters.</p> <ul style="list-style-type: none"> • Backlight • Display Parameters

4.18.1 Guidelines for setting the scroll rate

The scroll rate is used to control the speed of scrolling when auto scroll is enabled. Scroll rate defines how long each display variable will be shown on the display.

The time period is defined in seconds (for example, if scroll rate is set to 10, each display variable will be shown on the display for 10 seconds). The valid range is from 1 to 30 seconds, with a default value of 30 seconds.

4.18.2 Guidelines for setting the update period

The update period (or display rate) parameter controls how often the display is refreshed with current data.

The default is 200 milliseconds. The range is 100 to 10,000 milliseconds. The update period value applies to all displayed process variables.

4.18.3 Guidelines for setting the off-line password

The off-line password prevents unauthorized users from gaining access to the off-line menu.

4.18.4 Guidelines for setting the display language

The display can be configured to use any of the following languages for data and menus:

- English
- French
- German
- Spanish

4.18.5 Changing the display variables and precision

About this task

The display can scroll through up to 15 process variables in any order. You can select the process variables you wish to see and the order in which they should appear.

Additionally, you can configure display precision for each display variable. Display precision controls the number of digits to the right of the decimal place. The range of the display precision is 0 to 5.

The following table shows an example of a display variable configuration. Notice that you can repeat variables and you can choose a value of “None”. The actual appearance of each process variable on the display is described in [Using the transmitter display](#).

Table 4-20: Example of a display variable configuration

Display variable	Process variable
Display variable 1	Mass flow
Display variable 2	Volume flow

Table 4-20: Example of a display variable configuration (continued)

Display variable	Process variable
Display variable 3	Density
Display variable 4	Mass flow
Display variable 5	Volume flow
Display variable 6	Mass totalizer
Display variable 7	Mass flow
Display variable 8	Temperature
Display variable 9	Volume flow
Display variable 10	Volume totalizer
Display variable 11	Density
Display variable 12	Temperature
Display variable 13	None
Display variable 14	None
Display variable 15	None

ProLink III for changing display variables	<ol style="list-style-type: none"> Device Tools > Configuration > Transmitter Display > Display Variables tab For each display variable, select a process variable from the list. Enter a precision in the appropriate box under Decimal Places for x Variables box, where x is either Diagnostic, Process, or Totalizer. Click Apply.
Bus Parameters for changing display variables	<ol style="list-style-type: none"> Display variables: <p>Block Transducer: Block 1 (Slot 11)</p> <p>Indices 232 through 246</p> Display precision: <p>Block Transducer: Block 1 (Slot 11)</p> <p>Index 231 (Number of decimals)</p>

<p>EDD for changing the display variables</p>	<ol style="list-style-type: none"> 1. MMI Coriolis Flow > Transducer Block > Display Configuration <ol style="list-style-type: none"> a. Select Display Parameters. <ul style="list-style-type: none"> • Set values for Display Variable 1 through Display Variable 15 b. Select Display Precision. <ul style="list-style-type: none"> • Select Display Variable and set No. of Decimal.
---	---

4.19 Enabling LD optimization

About this task

LD Optimization is a special compensation that is specifically for hydrocarbon liquids. LD Optimization should not be used with any other process fluids. LD Optimization is available only with certain large sensor sizes. If your sensor can benefit from LD Optimization, the enable/disable option will appear in ProLink III or on the display. (Refer to [Figure B-11](#) to view the display path.)

Important

If you send the transmitter to a calibration facility to perform a water calibration, either during startup or any time thereafter, LD Optimization must be disabled. When you have completed the calibration, re-enable LD Optimization.

<p>Display path for LD optimization (scroll and select simultaneously for 4 seconds)</p>	<ol style="list-style-type: none"> 1. OFF-LINE MAINT > CFG > MTR F > FACTOR LD > LD OPT
---	---

4.20 Configuring pressure compensation

Due to process pressure change away from calibration pressure, there can be a change in sensor flow and density sensitivity. This change is called pressure effect. Pressure compensation corrects for these changes.

Not all sensors and applications require pressure compensation. Contact customer service before you configure pressure compensation.

Configuring pressure compensation requires three steps:

1. Determining pressure compensation values
2. Enabling pressure compensation
3. Selecting a pressure source

4.20.1 Pressure Compensation Values

There are three values involved in pressure compensation:

- *Flow factor* -- The flow factor is the percent change in flow rate per psi. Consult the product flow data sheet for your sensor for this value. You will need to reverse the sign of the flow factor. For example, if the flow factor in the product data sheet is -0.001% per psi, the pressure compensation flow factor would be $+0.001\%$ per psi.
- *Density factor* --The density factor is the change in fluid density, in g/cm^3 per psi. Consult the product data sheet for your sensor for this value. You will need to reverse the sign of the density factor. For example, if the density factor in the product data sheet is $-0.00004 \text{ g}/\text{m}^3$ per psi, the pressure compensation flow factor would be $+0.00004 \text{ g}/\text{m}^3$ per psi.
- *Flow calibration pressure* --The pressure at which the flow meter was calibrated. Refer to the calibration document shipped with your sensor. If the data is unavailable, use 20 psi. (1,4 bar).

4.20.2 Enabling pressure compensation

To enable pressure compensation, you will need the three pressure compensation values.

About this task

Use the following procedure to configure the totalizer block mode:

Procedure

1. Determine the method you are using to enable pressure compensation:
 - If you are using the EDD, go to [Step 2](#).
 - If you are using bus parameters, go to [Step 7](#).
 - If you are using ProLink III, go to [Step 8](#).
2. From the EDD, choose **MMI Coriolis Flow > Transducer Block > Compensation > Pressure**.
3. At Pressure Comp, select **Enabled**.
4. Specify values for **Flow Factor**, **Density Factor**, and **Cal Pressure**.
5. Set the **Pressure Units** value to match the pressure source.
6. Optionally, you can set **External Pressure** to a fixed pressure value.
7. For bus parameter:
 - a) Select **Enable pressure comp. > Block: Transducer Block 1 (Slot 11) Index 112 (enable pressure compensation)**.
 - b) Select **Pressure correction values > Block: Transducer Block 1 (Slot 11) Index 116 (flow factor) / Index 117 (density factor) / Index 118 (flow calibration pressure)**.
 - c) Select **Pressure units > Block: Transducer Block 1 (Slot 11) Index 115 (pressure units)**.
 - d) Select **Optional: Fixed pressure value > Block: Transducer Block 1 (Slot 11) Index 113 (pressure value)**.
8. Select **Device Tools > Configuration > Process Measurement > Pressure Compensation**.
9. Set **Pressure Compensation Status** to *Enabled*.
10. Enter the following values:
 - a) Enter the flow factor in the **Flow factor** box.

- b) Enter the density factor in the **Density factor** box.
 - c) Enter the flow calibration pressure in the **Flow Calibration Pressure** box.
11. Set the pressure units to match the source.
 12. Optionally, you can enter a fixed pressure value in the **External Pressure** box.
 13. Click **Apply**.

4.20.3 Configuring a pressure source

You need to choose one of two sources for pressure data: either Analog Output function block or Fixed pressure data.

About this task

- Analog Output function block -- This option allows the PLC to write a pressure value to the transmitter.
- Fixed pressure data -- This option uses a known, constant pressure value.

Note

If you configure a fixed pressure value, ensure that it is accurate. If you configure polling for pressure, ensure that the external pressure measurement device is accurate and reliable.

If you configure pressure compensation to use an AO block for pressure compensation, the other AO block remains available for temperature compensation. However, only one of the AO blocks can be set up for external pressure.

If you configure fixed pressure data, use the procedures described in [Enabling pressure compensation](#).

Use the following procedure to configure an AO function block for pressure compensation:

Procedure

1. Determine the method you are using to configure fixed pressure or an AO function block for pressure compensation:
 - If you are using the EDD, go to [Step 2](#).
 - If you are using bus parameters, go to [Step 4](#).
 - If you are using the display, go to [Step 5](#).
2. From the EDD, choose **MMI Coriolis Flow > Function Block > Analog Output n > Parameters > General**.
3. Set **In Channel** to pressure.

Note

When setting the IN channel to Pressure through the EDD, the OUT channel will be automatically set to Pressure as well.

4. For bus parameter:
 - a) Select **Configure channel**.
 - b) Then select **Block: Transducer Block 1 (Slot 11) Index 121 (AO Compensation, value = 1)**.

Note

Setting the IN channel through bus parameters does not automatically change the OUT channel. You must manually set the OUT channel to Pressure or the block will go into OSS mode.

- c) Select **Configure channel** .
 - d) Then select **Block: Analog Block Output Block (Slots 9 and 10) Index 37 (IN channel), value = 0x0b72 / Index 38 (OUT channel), value = 0x0b71**.
5. For the display, select **CONFIG AO > AO1 INCH**.
 6. Scroll thorough **AO1 PV UNITS > AO1 OUTCH > AO1 OUT UNITS** .
 7. Continue to scroll through **AO2 INCH > AO2 PV UNITS > AO2 OUTCH > AO2 OUT UNITS** as needed.

Related information

[Other/t_EnablingPressComp.dita](#)

4.21 Configuring temperature compensation

External temperature compensation can be used with the petroleum measurement application or the enhanced density application:

- If external temperature compensation is enabled, an external temperature value (or a fixed temperature value), rather than the temperature value from the Coriolis sensor, is used in petroleum measurement or enhanced density calculations only. The temperature value from the Coriolis sensor is used for all other calculations.
- If external temperature compensation is disabled, the temperature values from the Coriolis sensor is used in all calculations.

Configuring temperature compensation requires two steps:

1. Enabling external temperature compensation.
2. Configuring a temperature source.

4.21.1 Enabling Temperature Compensation

You can enable temperature compensation through either the EDD, the bus parameters, or ProLink III.

About this task

Use the following procedure to enable temperature compensation:

Procedure

-
1. **Note**
To configure temperature compensation through ProLink III, you must have Concentration Measurement as an application and under the **PROFIBUS** tab, you have to select `Acyclic` as the **Compensation Select** value.
-

Determine the method you are using to configure fixed temperature or an AO function block for temperature compensation:

- If you are using the EDD, go to [Step 2](#).

- If you are using ProLink III go to [Step 4](#).
 - If you are using bus parameters, go to [Step 6](#).
2. From the EDD, choose **MMI Coriolis Flow > Transducer Block > Compensation > Temperature**.
 3. Enable or disable **Ext Temp**.
 4. Select **Device Tools > Configuration > Process Measurement > Concentration Measurement**.
 5. At the bottom of the tab under **Line Temperature Data**, set the **Use External Temperature Value** field to `Enabled`.
 6. For bus parameter:
 - a) Select **Enable temperature comp**.
 - b) Then select **Block: Transducer Block 1 (Slot 11) Index 110 (enable temperature compensation)**.

4.21.2 Configuring a temperature source

External temperature data is reported through an analog output (AO) function block. The transmitter has two AO blocks, each of which can be assigned to a compensation variable channel.

About this task

Use the following procedure to configure an AO function block for temperature compensation:

Procedure

1. Determine the method you are using to configure fixed temperature or an AO function block for temperature compensation:
 - If you are using the EDD, go to [Step 2](#).
 - If you are using bus parameters, go to [Step 4](#).
 - If you are using the display, go to [Step 5](#).
2. From the EDD, choose **MMI Coriolis Flow > Function Block > Analog Output n > Parameters > General**.

Note

When setting the IN channel to Temperature through the EDD, the OUT channel is automatically set to Temperature as well.

3. Set **IN Channel** to Temperature.
4. For bus parameter:
 - a) Select **Configure channel**.
 - b) Then select **Block: Transducer Block 1 (Slot 11) Index 121 (AO Compensation), value = 1**.
 - c) Select **Configure channel**.

Note

Setting the IN channel through bus parameters does not automatically change the OUT channel. You must manually set the OUT channel to Temperature or the bloc will go into OOS mode.

- d) Then select **Block: Analog Output Block (Slots 9 and 10) Index 37 (IN channel), value = 0x0b1D / Index 38 (OUT channel), value = 0x0b6F.**
5. For the display, select **CONFIG AO > AO1 INCH.**
6. Scroll through **AO1 PV UNITS > AO1 OUTCH > AO1 OUT UNITS .**
7. Continue to scroll through **AO2 INCH > AO2 PV UNITS > AO2 OUTCH > AO2 OUT UNITS** as needed.

5 Configure device options and preferences

5.1 Configure the transmitter display

You can control the process variables shown on the display and a variety of display behaviors.

5.1.1 Configure the language used for the display

Display	OFF-LINE MAINT > OFF-LINE CONFIG > DISPLAY > LANG
ProLink III	Device Tools > Configuration > Transmitter Display > General

Display Language controls the language used for process data and menus on the display.

Procedure

Select the language you want to use.
The languages available depend on your transmitter model and version.

5.1.2 Configure the process variables and diagnostic variables shown on the display

You can control the process variables and diagnostic variables shown on the display, and the order in which they appear. The display can scroll through up to 15 variables in any order you choose. In addition, you can repeat variables or leave slots unassigned.

About this task

Procedure

For each display variable you want to change, assign the process variable you want to use.

Default display variable configuration

Display variable	Process variable assignment
Display Variable 1	Mass flow
Display Variable 2	Mass total
Display Variable 3	Volume flow
Display Variable 4	Volume total
Display Variable 5	Density
Display Variable 6	Temperature
Display Variable 7	Drive gain
Display Variable 8	None

Display variable	Process variable assignment
Display Variable 9	None
Display Variable 10	None
Display Variable 11	None
Display Variable 12	None
Display Variable 13	None
Display Variable 14	None
Display Variable 15	None

5.1.3 Configure the number of decimal places (precision) shown on the display

Display	Not available
ProLink III	Device Tools > Configuration > Transmitter Display > Display Variables

You can specify the number of decimal places (precision) that are shown on the display for each process variable or diagnostic variable. You can set the precision independently for each variable.

About this task

The display precision does not affect the actual value of the variable or the value used in calculations.

Procedure

1. Select a variable.
2. Set **Number of Decimal Places** to the number of decimal places you want shown when the process variable or diagnostic variable appears on the display.

Tip

The lower the precision, the greater the change must be for it to be reflected on the display. Do not set the precision too low or too high to be useful.

5.1.4 Configure the refresh rate of data shown on the display

Display	OFF-LINE MAINT > OFF-LINE CONFG > DISPLAY > RATE
ProLink III	Device Tools > Configuration > Transmitter Display > Display Variables

You can set **Refresh Rate** to control how frequently data is refreshed on the display.

Procedure

Set **Refresh Rate** to the desired value.

5.1.5 Enable or disable automatic scrolling through the display variables

Display	OFF-LINE MAINT > OFF-LINE CONFIG > DISPLAY > AUTO SCROLL
ProLink III	Device Tools > Configuration > Transmitter Display > General

You can configure the display to automatically scroll through the configured display variables or to show a single display variable until the operator activates **Scroll**. When you set automatic scrolling, you can also configure the length of time each display variable is displayed.

Procedure

1. Enable or disable **Auto Scroll** as desired.

Option	Description
Enabled	The display automatically scrolls through each display variable as specified by Scroll Rate . The operator can move to the next display variable at any time using Scroll .
Disabled (default)	The display shows Display Variable 1 and does not scroll automatically. The operator can move to the next display variable at any time using Scroll .

2. If you enabled **Auto Scroll**, set **Scroll Rate** as desired.
The default value is 10 seconds.

Tip

Scroll Rate may not be available until you apply **Auto Scroll**.

5.1.6 Enable or disable the display backlight

Display	OFF-LINE MAINT > OFF-LINE CONFIG > DISPLAY > BKLT
ProLink III	Device Tools > Configuration > Transmitter Display > General

You can enable or disable the display backlight.

Procedure

Enable or disable **Backlight**.
The default setting is Enabled.

5.1.7 Enable or disable Status LED Blinking

Display	Not available
ProLink III	Device Tools > Configuration > Transmitter Display > General

By default, the status LED blinks (flashes) to indicate unacknowledged alerts. If you disable **Status LED Blinking**, the status LED does not blink, whether alerts are acknowledged or not. It still changes color to indicate active alerts.

Procedure

Enable or disable **Status LED Blinking**.

The default setting is Enabled.

5.2 Enable or disable operator actions from the display

You can configure the transmitter to let the operator perform specific actions using the display.

5.2.1 Enable or disable Totalizer Start/Stop from the display

Display	OFF-LINE MAINT > OFF-LINE CONFIG > DISPLAY > TOTALS STOP
ProLink III	Device Tools > Configuration > Totalizer Control Methods

You can control whether or not the operator is able to start and stop totalizers and inventories from the display.

About this task

Restriction

- You cannot start and stop totalizers individually from the display. All totalizers are started or stopped together.
- You cannot start or stop inventories separately from totalizers. When a totalizer is started or stopped, the associated inventory is also started or stopped.
- If the petroleum measurement application is installed, the operator must enter the off-line password to perform this function, even if the off-line password is not enabled.

Procedure

1. Ensure that at least one totalizer is configured as a display variable.
2. Enable or disable **Totalizer Reset** as desired.

Option	Description
Enabled	Operators can start and stop totalizers and inventories from the display, if at least one totalizer is configured as a display variable.
Disabled (default)	Operators cannot start and stop totalizers and inventories from the display.

5.2.2 Enable or disable Totalizer Reset from the display

Display	OFF-LINE MAINT > OFF-LINE CONFIG > DISPLAY > TOTALS RESET
ProLink III	Device Tools > Configuration > Totalizer Control Methods

You can configure whether or not the operator is able to reset totalizers from the display.

About this task

Restriction

- This parameter does not apply to inventories. You cannot reset inventories from the display.
- You cannot use the display to reset all totalizers as a group. You must reset totalizers individually.
- If the petroleum measurement application is installed, the operator must enter the off-line password to perform this function, even if the off-line password is not enabled.

Procedure

1. Ensure that the totalizers you want to reset have been configured as display variables.
If the totalizer is not configured as a display variable, the operator will not be able to reset it.
2. Enable or disable resetting the totalizer as desired.

Option	Description
Enabled	Operators can reset a totalizer from the display, if the totalizer is configured as a display variable.
Disabled (default)	Operators cannot reset totalizers from the display.

5.2.3 Enable or disable the Acknowledge All Alerts display command

Display	OFF-LINE MAINT > OFF-LINE CONFIG > DISPLAY > ALERT
ProLink III	Device Tools > Configuration > Transmitter Display > Ack All

You can configure whether or not the operator can use a single command to acknowledge all alerts from the display.

Procedure

1. Ensure that the alert menu is accessible from the display.
To acknowledge alerts from the display, operators must have access to the alert menu.
2. Enable or disable **Acknowledge All Alerts** as desired.

Option	Description
Enabled (default)	Operators can use a single display command to acknowledge all alerts at once.
Disabled	Operators cannot acknowledge all alerts at once. Each alert must be acknowledged separately.

5.3 Configure security for the display menus

Display	OFF-LINE MAINT > OFF-LINE CONFIG > DISPLAY
ProLink III	Device Tools > Configuration > Transmitter Display > Display Security

You can control operator access to different sections of the display off-line menu. You can also configure a password to control access.

Procedure

1. To control operator access to the maintenance section of the off-line menu, enable or disable **Off-Line Menu**.

Option	Description
Disabled	Operator cannot access the maintenance section of the off-line menu.

2. To control operator access to the alert menu, enable or disable **Alert Menu**.

Option	Description
Enabled (default)	Operator can access the alert menu. This access is required to view and acknowledge alerts, but is not required for Smart Meter Verification (if applicable), configuration, or calibration.
Disabled	Operator cannot access the alert menu.

Note

The transmitter status LED changes color to indicate that there are active alerts, but does not show specific alerts.

3. To require a password for access to the maintenance section of the off-line menu, enable or disable **Off-Line Password**.

Option	Description
Enabled	Operator is prompted for the off-line password at entry to the Smart Meter Verification menu (if applicable) or entry to the maintenance section of the off-line menu.
Disabled (default)	No password is required for entry to the Smart Meter Verification menu (if applicable) or entry to the maintenance section of the off-line menu.

- To require a password to access the alert menu, enable or disable **Alert Password**.

Option	Description
Enabled	Operator is prompted for the off-line password at entry to the alert menu.
Disabled (default)	No password is required for entry to the alert menu.

If both **Off-Line Password** and **Alert Password** are enabled, the operator is prompted for the off-line password to access the off-line menu, but is not prompted thereafter.

- Set **Off-Line Password** to the desired value.

The default value is 1234. The range is 0000 to 9999.

The same value is used for both the off-line password and the alert password.

Tip

Record your password for future reference.

5.4 Configure alert handling

The alert handling parameters control the transmitter's response to process and device conditions.

5.4.1 Configure Fault Timeout

Display	Not available
ProLink III	Device Tools > Configuration > Fault Processing

Fault Timeout controls the delay before fault actions are performed.

Procedure

- Set **Fault Timeout** as desired.

The default value is 0 seconds. The range is 0 to 60 seconds.

If you set **Fault Timeout** to 0, fault actions are performed as soon as the alert condition is detected.

The fault timeout period begins when the transmitter detects an alert condition. During the fault timeout period, the transmitter continues to report its last valid measurements.

If the fault timeout period expires while the alert is still active, the fault actions are performed. If the alert condition clears before the fault timeout expires, no fault actions are performed.

5.4.2 Configure Status Alert Severity

Display	Not available
ProLink III	Device Tools > Configuration > Alert Severity

Use **Status Alert Severity** to control the fault actions that the transmitter performs when it detects an alert condition.

About this task

Restriction

- For some alerts, **Status Alert Severity** is not configurable.
- For some alerts, **Status Alert Severity** can be set only to two of the three options.

Tip

Use the default settings for **Status Alert Severity** unless you have a specific requirement to change them.

Procedure

1. Select a status alert.
2. For the selected status alert, set **Status Alert Severity** as desired.

Option	Description
Fault	<p>Actions when fault is detected:</p> <ul style="list-style-type: none"> • The alert is posted to the Alert List. • Outputs go to the configured fault action (after Fault Timeout has expired, if applicable). • Digital communications go to the configured fault action (after Fault Timeout has expired, if applicable). • The status LED (if available) changes to red or yellow (depending on alert severity). <p>Actions when alert clears:</p> <ul style="list-style-type: none"> • Outputs return to normal behavior. • Digital communications return to normal behavior.
Informational	<p>Actions when fault is detected:</p> <ul style="list-style-type: none"> • The alert is posted to the Alert List. • The status LED (if available) changes to red or yellow (depending on alert severity). <p>Actions when alert clears:</p> <ul style="list-style-type: none"> • The status LED (if available) returns to green and may or may not flash.

Status alerts and options for Status Alert Severity

Table 5-1: Status alerts and Status Alert Severity

Alert code	Status message	Default severity	Notes	Configurable?
A001	EEPROM Error (Core Processor)	Fault		No
A002	RAM Error (Core Processor)	Fault		No
A003	No Sensor Response	Fault		Yes
A004	Temperature Overrange	Fault		No
A005	Mass Flow Rate Overrange	Fault		Yes
A006	Characterization Required	Fault		Yes
A008	Density Overrange	Fault		Yes
A009	Transmitter Initializing/ Warming Up	Fault		Yes
A010	Calibration Failure	Fault		No
A011	Zero Calibration Failed: Low	Fault		Yes
A012	Zero Calibration Failed: High	Fault		Yes
A013	Zero Calibration Failed: Unstable	Fault		Yes
A014	Transmitter Failure	Fault		No
A016	Sensor RTD Failure	Fault		Yes
A020	No Flow Cal Value	Fault		Yes
A021	Incorrect Sensor Type (K1)	Fault		No
A026	Sensor/Transmitter Communications Failure	Fault		No
A032	Meter Verification in Progress: Outputs to Fault	Varies	Applies only to transmitters with Smart Meter Verification. If outputs are set to Last Measured Value, severity is Info. If outputs are set to Fault, severity is Fault.	No
A033	Insufficient Right/Left Pickoff Signal	Fault		Yes
A034	Meter Verification Failed	Fault	Applies only to transmitters with Smart Meter Verification.	Yes
A102	Drive Overrange	Informational		Yes

Table 5-1: Status alerts and Status Alert Severity (continued)

Alert code	Status message	Default severity	Notes	Configurable?
A104	Calibration in Progress	Informational	Can be set to either Informational or Ignore, but cannot be set to Fault.	Yes
A105	Slug Flow	Informational		Yes
A106	Burst Mode Enabled	Informational	Can be set to either Informational or Ignore, but cannot be set to Fault.	Yes
A107	Power Reset Occurred	Informational	Normal transmitter behavior; occurs after every power cycle.	Yes
A131	Meter Verification in Progress: Outputs to Last Measured Value	Informational	Applies only to transmitters with Smart Meter Verification.	Yes

5.5 Configure informational parameters

The informational parameters can be used to identify or describe your meter. They are not used in process measurement and they are not required.

5.5.1 Configure Sensor Serial Number

Display	Not available
ProLink III	Device Tools > Configuration > Informational Parameters > Sensor

Sensor Serial Number lets you store the serial number of the sensor component of your flowmeter in transmitter memory. This parameter is not used in processing and is not required.

Procedure

1. Obtain the sensor serial number from your sensor tag.
2. Enter the serial number in the **Sensor Serial Number** field.

5.5.2 Configure Sensor Material

Display	Not available
ProLink III	Device Tools > Configuration > Informational Parameters > Sensor

Sensor Material lets you store the type of material used for your sensor's wetted parts in transmitter memory. This parameter is not used in processing and is not required.

Procedure

1. Obtain the material used for your sensor's wetted parts from the documents shipped with your sensor, or from a code in the sensor model number.

- To interpret the model number, refer to the product data sheet for your sensor.
2. Set **Sensor Material** to the appropriate option.

5.5.3 Configure Sensor Liner Material

Display	Not available
ProLink III	Device Tools > Configuration > Informational Parameters > Sensor

Sensor Liner Material lets you store the type of material used for your sensor liner in transmitter memory. This parameter is not used in processing and is not required.

Procedure

1. Obtain your sensor's liner material from the documents shipped with your sensor, or from a code in the sensor model number.
To interpret the model number, refer to the product data sheet for your sensor.
2. Set **Sensor Liner Material** to the appropriate option.

5.5.4 Configure Sensor Flange Type

Display	Not available
ProLink III	Device Tools > Configuration > Informational Parameters > Sensor

Sensor Flange Type lets you store your sensor's flange type in transmitter memory. This parameter is not used in processing and is not required.

Procedure

1. Obtain your sensor's flange type from the documents shipped with your sensor, or from a code in the sensor model number.
To interpret the model number, refer to the product data sheet for your sensor.
2. Set **Sensor Flange Type** to the appropriate option.

5.5.5 Configure Descriptor

Display	Not available
ProLink III	Device Tools > Configuration > Informational Parameters > Transmitter

Descriptor lets you store a description in transmitter memory. The description is not used in processing and is not required.

Procedure

- Enter a description for the transmitter or device
You can use up to 16 characters for the description.

6 Complete the configuration

6.1 Test or tune the system using sensor simulation

Use sensor simulation to test the system's response to a variety of process conditions, including boundary conditions, problem conditions, or alert conditions, or to tune the loop.

Prerequisites

Before enabling sensor simulation, ensure that your process can tolerate the effects of the simulated process values.

About this task

Procedure

1. Navigate to the sensor simulation menu.
2. Enable sensor simulation.
3. For mass flow, set **Wave Form** as desired and enter the required values.

Option	Required values
Fixed	Fixed Value
Sawtooth	Period Minimum Maximum
Sine	Period Minimum Maximum

4. For density, set **Wave Form** as desired and enter the required values.

Option	Required values
Fixed	Fixed Value
Sawtooth	Period Minimum Maximum
Sine	Period Minimum

Option	Required values
	Maximum

- For temperature, set **Wave Form** as desired and enter the required values.

Option	Required values
Fixed	Fixed Value
Sawtooth	Period Minimum Maximum
Sine	Period Minimum Maximum

- Observe the system response to the simulated values and make any appropriate changes to the transmitter configuration or to the system.
- Modify the simulated values and repeat.
- When you have finished testing or tuning, disable sensor simulation.

6.1.1 Sensor simulation

Sensor simulation allows you to test the system or tune the loop without having to create the test conditions in your process. When sensor simulation is enabled, the transmitter reports the simulated values for mass flow, density, and temperature, and takes all appropriate actions. For example, the transmitter might apply a cutoff, activate an event, or post an alert.

When sensor simulation is enabled, the simulated values are stored in the same memory locations used for process data from the sensor. The simulated values are then used throughout transmitter functioning. For example, sensor simulation will affect:

- All mass flow rate, temperature, and density values displayed or reported via outputs or digital communications
- The mass total and mass inventory values
- All volume calculations and data, including reported values, volume totals, and volume inventories
- All mass, temperature, density, or volume values logged to Data Logger

Sensor simulation does not affect any diagnostic values.

Unlike actual mass flow rate and density values, the simulated values are not temperature-compensated (adjusted for the effect of temperature on the sensor's flow tubes).

6.2 Back up transmitter configuration

ProLink III provides a configuration upload/download function which allows you to save configuration sets to your PC. This allows you to back up and restore your transmitter configuration. This is also a convenient way to replicate a configuration across multiple devices.

About this task

Restriction

This function is not available with any other communications tools.

Procedure

- To back up the transmitter configuration using ProLink III:
 - a) Choose **Device Tools > Configuration Transfer > Save or Load Configuration Data**.
 - b) In the **Configuration** groupbox, select the configuration data you want to save.
 - c) Click **Save**, then specify a file name and location on your computer.
 - d) Click **Start Save**.

Results

The backup file is saved to the specified name and location. It is saved as a text file and can be read using any text editor.

7 Transmitter operation

7.1 Record the process variables

About this task

Emerson suggests that you make a record of specific process variable measurements, including the acceptable range of measurements, under normal operating conditions. This data will help you recognize when the process or diagnostic variables are unusually high or low, and may help you diagnose and troubleshoot application issues.

Procedure

Record the following process and diagnostic variables, under normal operating conditions.

Variable	Measurement		
	Typical average	Typical high	Typical low
Flow rate			
Density			
Temperature			
Tube frequency			
Pickoff voltage			
Drive gain			

7.2 Viewing process variables

Process variables include measurements such as mass flow rate, volume flow rate, temperature, and density. You can view process variables with the display (if your transmitter has a display), ProLink III, a PROFIBUS configuration tool (such as Simatic PDM) using the EDD, or from a Class 2 PROFIBUS host using bus parameters.

Using the display

By default, the display shows the mass flow rate, mass total, volume flow rate, volume total, temperature, density, and drive gain. If desired, you can configure the display to show other process variables. For more information, refer to [Changing the display variables and precision](#).

The LCD panel reports the abbreviated name of the process variable (for example, DENS for density), the current value of that process variable, and the associated unit of measure (for example, G/CM³). See [Using the transmitter display](#) for information on the codes and abbreviations used for display variables.

To view a process variable with the display:

- If Auto Scroll is enabled, wait until the desired process variable appears on the LCD panel.
- If Auto Scroll is not enabled, Scroll until the name of the desired process variable either:

- Appears on the process variable line,
- Begins to alternate with the units of measure

The precision of variables shown on the display is configurable, as described in [Changing the display variables and precision](#). The display precision affects only the value shown on the display, and does not affect the actual process value stored in the transmitter.

Process variable values are displayed using either standard decimal notation or exponential notation:

- Values < 100,000,000 are displayed in decimal notation (such as 1234567.8).
- Values ≥ 100,000,000 are displayed using exponential notation (such as 1.000E08)
 - If the value is less than the precision configured for that process variable, the value is displayed as 0 (there is no exponential notation for fractional numbers).
 - If the value is too large to be displayed with the configured precision, the displayed precision is reduced (that is, the decimal point is shifted to the right) as required so that the value can be displayed.

Using ProLink III

The Process Variables display automatically when you first connect to the transmitter. This window displays current values for the standard process variables (mass, volume, density, temperature, external pressure, and external temperature).

To view petroleum measurement process variables (if the petroleum measurement application is enabled), select the desired variable from the drop-down menu in the **Process Variables** window.

To view concentration measurement process variables (if the concentration measurement application is enabled), select the desired variable from the drop-down menu in the **Process Variables** window. The concentration measurement process variables that are displayed depend on the configuration of the concentration measurement application.

Using PROFIBUS EDD

Select **View > Process Variables** to view standard process variables. petroleum measurement and concentration measurement variables are not displayed on this screen. Select **Device > API** to view petroleum measurement variables. Select **Device > CM Process Variables** to view concentration measurement variables.

Using bus parameters

To view standard process variables, examine index 26 (AI Out) of the appropriate AI function block. Refer to [Setting the IO mode](#) for information about how slots correspond to AI function blocks.

7.3 I&M functions

The transmitter implements the following PROFIBUS identification and maintenance (I&M) functions:

- I&M 0
- I&M 1
- I&M 2

- PA & M0

Refer to Amendment 3 to the PROFIBUS Profile for Process Control Devices V 3.01: Identification and Maintenance Functions Version 1.0, December 2004 Order No. 3.042.

The I&M functions contain a variety of device and manufacturer information, all of which is hard-coded (read only). The I&M functions are not accessible through ProLink III or the display. If you are using Siemens Simatic PDM, v6.0 SP2 or higher is required. Earlier versions do not support I&M functions.

Refer to [I & M functions](#) for the bus parameters associated with the I&M functions.

7.4 Using sensor simulation mode

Sensor simulation mode causes simulated values to be substituted for actual process data from the sensor. Sensor simulation mode can be enabled only with ProLink III.

About this task

Sensor simulation is only available if you have an enhanced core processor. For more information about sensor simulation mode, refer to [Test or tune the system using sensor simulation](#).

ProLink III for Sensor simulation	<ol style="list-style-type: none"> 1. Device Tools > Diagnostics > Testing > Sensor Simulation 2. Select Enable Simulation Status. 3. Select a wave form from the Wave Form lists for mass flow, density, and temperature. <ol style="list-style-type: none"> a. If you select a Fixed wave, enter a value in the Fixed Value box. a. If you select a Triangular or sine wave, enter the period in the Period box. b. Enter minimum and maximum amplitude in the Minimum and Maximum boxes. 4. Click Apply.
---	---

7.5 Accessing diagnostic information with a PROFIBUS host

The transmitter sends diagnostic information to a PROFIBUS host in the form of slave diagnostic response bytes. The number of bytes sent depends on whether the transmitter is configured for Manufacturer-specific or Profile-specific mode.

Refer to [Setting the IO mode](#) for information about the mode, and [Slave diagnostic response bytes](#) for information on interpreting the diagnostic bytes.

7.6 Viewing transmitter status and alerts

You can view transmitter status using the display, ProLink III, EDD, or bus parameters. Depending on the method chosen, different information is displayed.

Using the display

The display reports alerts in two ways:

1. With a status LED, which reports only that one or more alerts has occurred.
2. Through the alert queue, which reports each specific alert.

Note

If access to the alert menu from the display has been disabled (refer to [Configuring the display](#)), then the display will not list alert codes in an alert queue and the status LED will not flash. The status LED will indicate status using solid green, yellow, or red.

The status LED is located at the top of the following figure. The status LED can be in one of six possible states, as listed in [Table 7-1](#). The procedure for responding to alerts is shown in [Figure B-2](#).

Figure 7-1: Status LED

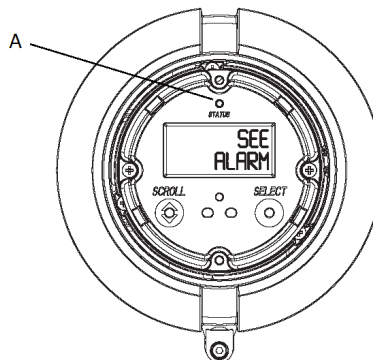

A. Status LED

Table 7-1: Status LED states

Status LED state	Alert priority
Green	No alert -- normal operating mode
Flashing green ⁽¹⁾	Unacknowledged corrected condition
Yellow	Acknowledged low severity alert
Flashing yellow ⁽¹⁾	Unacknowledged low severity alert
Red	Acknowledged high severity alert
Flashing Red ⁽¹⁾	Unacknowledged high severity alert

⁽¹⁾ If the display alert menu has been disabled, alerts cannot be acknowledged. In this case, the status LED never indicate an unacknowledged alert.

Using ProLink III

ProLink III provides allows you to view alert information by choosing **Device Tools > Alerts**. The alerts are divided into three categories: Failed: Fix Now, Maintenance: Fix Soon, and

Advisory: Informational. For a more complete view of each Alert, click on the **Detail View** button.

Using EDD

The transmitter sets its PROFIBUS output status to bad or uncertain whenever an alert condition occurs. You can view the current alerts by selecting **View > Device Status** and then selecting **Critical, Informational**, or **Operational**. All possible alerts are shown, independent of configured alert severity. Currently active alerts are shown by a check mark.

Using bus parameters

The transmitter sets its PROFIBUS output status to bad or uncertain whenever an alert condition occurs. You can view alerts by reading the status words of the block where the alert originated. The status words are one or more parameters whose bits indicate alert conditions:

- Index 23 (Alert summary) of each AI function block (Slot 1, 2, 3, and 5).
- Indies 139–146 of transducer block 1 (Slot 11).

You must view all of the status words to get a comprehensive list of current alerts.

7.7 View and acknowledge status alerts

The transmitter posts status alerts whenever a process variable exceeds its defined limits or the transmitter detects a fault condition. You can view active alerts, and you can acknowledge alerts. Acknowledging alerts is not required.

7.7.1 View and acknowledge alerts using the display

You can view a list containing all alerts that are active, or inactive but unacknowledged.

Prerequisites

Operator access to the alert menu must be enabled (default setting). If operator access to the alert menu is disabled, you must use another method to view or acknowledge status alerts.

About this task

Note

Only Fault and Informational alerts are listed. The transmitter automatically filters out alerts with **Status Alert Severity** set to Ignore.

Procedure

See [Figure 7-2](#).

Figure 7-2: Using the display to view and acknowledge the status alerts (alarms)

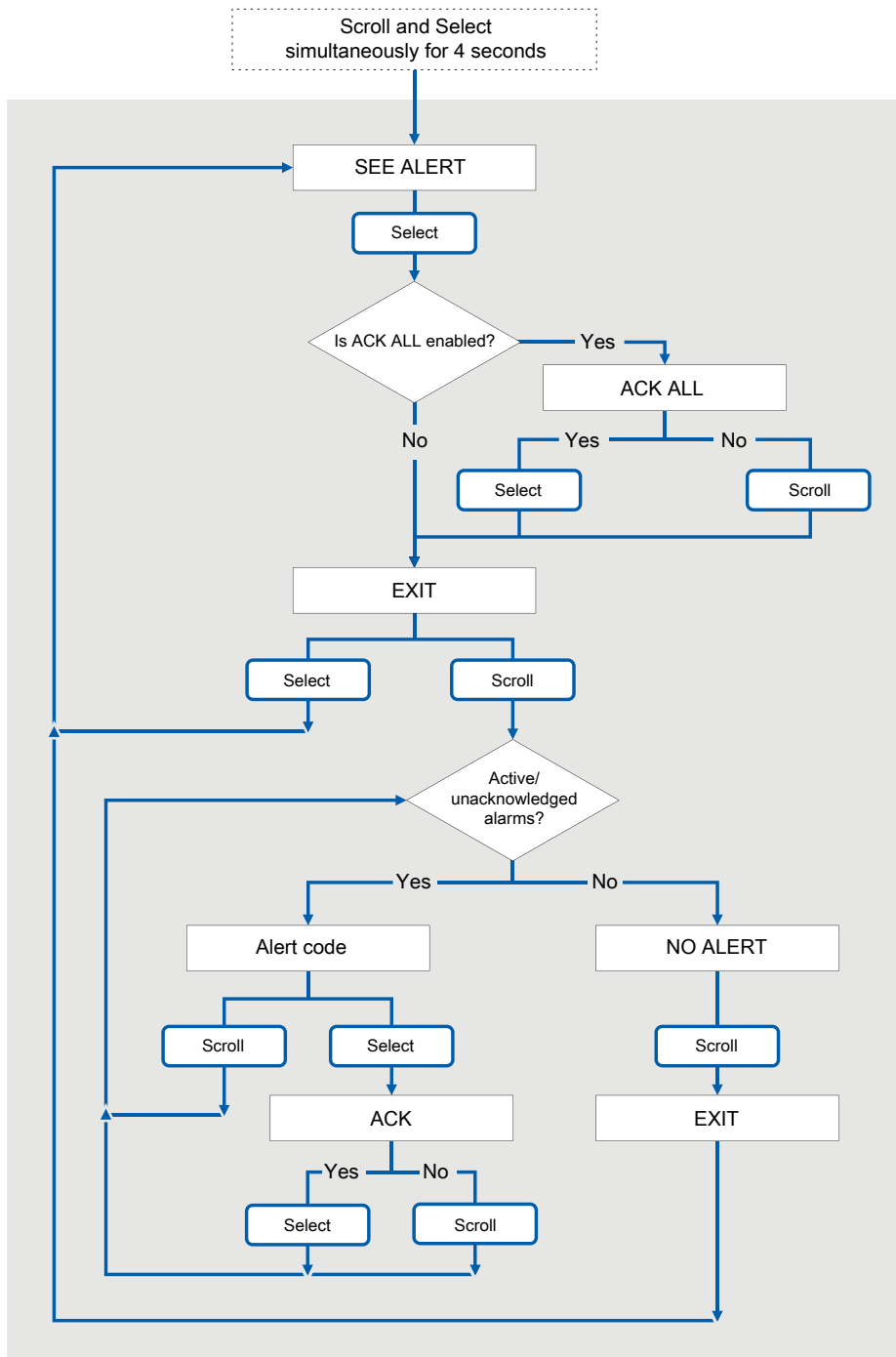

Postrequisites

- To clear the following alerts, you must correct the problem, acknowledge the alert, then power-cycle the transmitter: A001, A002, A010, A011, A012, A013, A018, A019, A022, A023, A024, A025, A028, A029, A031.
- For all other alerts:
 - If the alert is inactive when it is acknowledged, it will be removed from the list.
 - If the alert is active when it is acknowledged, it will be removed from the list when the alert condition clears.

7.7.2 View and acknowledge alerts using ProLink III

You can view a list containing all alerts that are active, or inactive but unacknowledged. From this list, you can acknowledge individual alerts or choose to acknowledge all alerts at once.

Procedure

1. View alerts on the ProLink III **Device Tools > Alerts tab**.

All active or unacknowledged alerts are listed, and displayed according to the following categories:

Category	Description
Failed: Fix Now	A meter failure has occurred and must be addressed immediately.
Maintenance: Fix Soon	A condition has occurred that can be fixed at a later time.
Advisory: Informational	A condition has occurred, but requires no maintenance from you.

Notes

- All fault alerts are displayed in the **Failed: Fix Now** category.
- All information alerts are displayed in either the **Maintenance: Fix Soon** category or the **Advisory: Informational** category. The category assignment is hard-coded.
- The transmitter automatically filters out alerts with **Alert Severity** set to Ignore.

2. To acknowledge a single alert, check the **Ack** checkbox for that alert. To acknowledge all alerts at once, click **Ack All**.

Postrequisites

- To clear the following alerts, you must correct the problem, acknowledge the alert, then power-cycle the transmitter: A001, A002, A010, A011, A012, A013, A018, A019, A022, A023, A024, A025, A028, A029, A031.
- For all other alerts:
 - If the alert is inactive when it is acknowledged, it will be removed from the list.
 - If the alert is active when it is acknowledged, it will be removed from the list when the alert condition clears.

7.7.3 Alert data in transmitter memory

The transmitter maintains three sets of data for every alert that is posted.

For each alert occurrence, the following three sets of data are maintained in transmitter memory:

- Alert List
- Alert Statistics
- Recent Alerts

Alert data structure	Transmitter action if condition occurs	
	Contents	Clearing
Alert List	As determined by the alert status bits, a list of: <ul style="list-style-type: none"> • All currently active alerts • All previously active alerts that have not been acknowledged 	Cleared and regenerated with every transmitter power cycle
Alert Statistics	One record for each alert (by alert number) that has occurred since the last master reset. Each record contains: <ul style="list-style-type: none"> • A count of the number of occurrences • Timestamps for the most recent posting and clearing 	Not cleared; maintained across transmitter power cycles
Recent Alerts	50 most recent alert postings or alert clearings	Not cleared; maintained across transmitter power cycles

7.8 Using the totalizers and inventories

The totalizers keep track of the total amount of mass or volume measured by the transmitter over a period of time. The totalizers can be started and stopped, and the totals can be viewed and reset.

The inventories track the same values as the totalizers. Whenever totalizers are started or stopped, all inventories (including the petroleum measurement volume inventory and concentration measurement inventories) are started or stopped automatically. However, when totalizers are reset, inventories are not reset automatically—you must reset inventories separately. This allows you to use the inventories to keep running totals across multiple totalizer resets.

You can view all totalizer and inventory values using any of the communication tools: the display, ProLink III, the EDD, or bus parameters. Specific starting, stopping, and resetting functionality depends on the tool you are using. If you are using the display, consult the display flow chart in [Figure B-9](#).

7.8.1 Viewing current values for totalizers and inventories

You can view current totals for the totalizers and inventories with the display (if your transmitter has a display), ProLink III, PROFIBUS EDD, or PROFIBUS bus parameters.

Using the display

You cannot view current totals with the display unless the display has been configured to show them. For more information, refer to [Configuring the display](#).

To view a totalizer or inventory value, **Scroll** until the LCD panel shows the word TOTAL in the lower left and the desired units in the lower right. Refer to the following table and [Figure 7-3](#).

Table 7-2: Display Totalizers and Inventories

Totalizer/inventory	Unit name on display
Mass total	Mass unit
Mass inventory	Mass unit alternating with MASSI
Volume total (liquid)	Volume unit
Volume inventory (liquid)	Volume unit alternating with LVOLI
Gas standard volume total	Volume unit
Gas standard volume inventory	Volume unit alternating with GSV I
Petroleum measurement corrected volume total	Volume unit alternating with TCORR (Temperature-corrected total)
Petroleum measurement corrected volume inventory	Volume unit alternating with TCORI (Temperature-corrected inventory)
ED net mass total	Mass unit alternating with NET M
ED net volume total	Mass unit alternating with NET MI
ED net volume inventory	Mass unit alternating with NETV
ED standard volume total	Mass unit alternating with STD V
ED standard volume inventory	Mass unit alternating with STDVI

Figure 7-3: Totalizer and inventory values on display

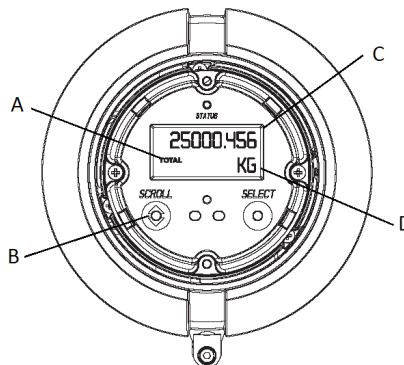

- A. TOTAL
- B. Scroll optical switch
- C. Current value
- D. Units of measure

Using ProLink III

To view the current value of the totalizers and inventories with ProLink III, select **Device Tools > Totalizers and Inventories**. By default, ProLink III can see totals in process variables when they have been assigned.

Using EDD

To view the current value of the totalizers and inventories:

- For standard mass, liquid standard volume, and gas standard volume, select **View >> Process Variables > Totalizer** and then select either **Mass** or **Volume**. (If the transmitter is configured to use gas standard volume, then **Volume** will be replaced by **Gas Standard Volume**.) Totals and inventories are displayed together.
- For petroleum measurement, select **Device > Device > API Totalizer**.
- For concentration measurement, select **Device > Device > CM Totalizer**.

Using bus parameters

To view the current value of the totalizers and inventories, examine index 26 (TOT Total) of each totalizer function block (Slots 4, 6, 7, and 8).

7.9 Read totalizer and inventory values

Totalizers keep track of the total amount of mass or volume measured by the transmitter since the last totalizer reset. Inventories keep track of the total amount of mass or volume measured by the transmitter since the last inventory reset.

About this task

Tip

You can use the inventories to keep a running total of mass or volume across multiple totalizer resets.

7.10 Start and stop totalizers and inventories

When you start a totalizer, it tracks process measurement. In a typical application, its value increases with flow. When you stop a totalizer, it stops tracking process measurement and its value does not change with flow. Inventories are started and stopped automatically, when totalizers are started and stopped.

About this task

Important

Totalizers and inventories are started or stopped as a group. When you start any totalizer, all other totalizers and all inventories are started simultaneously. When you stop any totalizer, all other totalizers and all inventories are stopped simultaneously. You cannot start or stop inventories directly.

7.10.1 Start and stop totalizers and inventories using the display

Prerequisites

- The Totalizer Start/Stop display function must be enabled.
- At least one totalizer must be configured as a display variable.

Procedure

- To start all totalizers and inventories using the display:

Note

If the PLC is connected and communicating, the start/stop and reset totalizers commands might be overriding any totalizer commands from the local display or from ProLink III.

- a) **Scroll** until the word TOTAL appears in the lower left corner of the display.

Important

Because all totalizers are started or stopped together, it does not matter which total you use.

- b) **Select**.
 - c) **Scroll** until START appears beneath the current totalizer value.
EXIT displays beneath the current totalizer value.
 - d) **Select**.
 - e) **Select** again to confirm.
 - f) **Scroll** to EXIT.
- To stop all totalizers and inventories using the display:
 - a) **Scroll** until the word TOTAL appears in the lower left corner of the display.

Important

Because all totalizers are started or stopped together, it does not matter which total you use.

- b) **Select**.
- c) **Scroll** until STOP appears beneath the current totalizer value.
- d) **Select**.
- e) **Select** again to confirm.
- f) **Scroll** to EXIT.

7.11 Reset totalizers

When you reset a totalizer, the transmitter sets its value to 0. It does not matter whether the totalizer is started or stopped. If the totalizer is started, it continues to track process measurement.

About this task

Tip

When you reset a single totalizer, the values of other totalizers are not reset. Inventory values are not reset.

7.11.1 Reset totalizers using the display

Prerequisites

- The Totalizer Reset display function must be enabled.
- The totalizer that you want to reset must be configured as a display variable. For example:
 - If you want to reset the mass totalizer, **Mass Total** must be configured as a display variable.
 - If you want to reset the volume totalizer, **Volume Total** must be configured as a display variable.

Procedure

- To reset the mass totalizer:
 - a) **Scroll** until the mass totalizer value appears.
 - b) **Select**.
`Exit` displays beneath the current totalizer value.
 - c) **Scroll** until `Reset` displays beneath the current totalizer value.
 - d) **Select**.
`Reset` and `Yes?` alternately flash beneath the current totalizer value.
 - e) **Select** again to confirm.
 - f) **Scroll** to EXIT.
 - g) **Select**.
- To reset the volume totalizer:
 - a) **Scroll** until the volume totalizer value appears.
 - b) **Select**.
`Exit` displays beneath the current totalizer value.
 - c) **Scroll** until `Reset` displays beneath the current totalizer value.

- d) **Select.**
Reset and Yes? alternately flash beneath the current totalizer value.
- e) **Select** again to confirm.
- f) **Scroll** to EXIT.
- g) **Select.**

7.12 Reset inventories

ProLink III	Device Tools > Totalizer Control > Totalizer and Inventories > Reset Mass Inventory Device Tools > Totalizer Control > Totalizer and Inventories > Reset Volume Inventory Device Tools > Totalizer Control > Totalizer and Inventories > Reset Gas Inventory Device Tools > Totalizer Control > Totalizer and Inventories > Reset All Inventories
-------------	--

When you reset an inventory, the transmitter sets its value to 0. It does not matter whether the inventory is started or stopped. If the inventory is started, it continues to track process measurement.

About this task

Tip

Mass and volume inventory totals cannot be set separately. They can only be reset together simultaneously.

8 Measurement support

8.1 Options for measurement support

Micro Motion provides several measurement support procedures to help you evaluate and maintain your flowmeter's accuracy.

The following methods are available:

- Smart Meter Verification (SMV) evaluates the structural integrity of the sensor tubes by comparing current tube stiffness to the stiffness measured at the factory. Stiffness is defined as the load per unit deflection, or force divided by displacement. Because a change in structural integrity changes the sensor's response to mass and density, this value can be used as an indicator of measurement performance.
- Meter validation compares flowmeter measurements reported by the transmitter to an external measurement standard. Meter validation requires one data point.
- Calibration establishes the relationship between a process variable and the signal produced at the sensor. You can calibrate the flowmeter for zero, density, and temperature. Density and temperature calibration require two data points (low and high) and an external measurement for each.

Tip

- Perform SMV at regular intervals to get the best data on your meter's performance.
 - To prove the meter against a regulatory standard, or to correct measurement error, use meter validation and meter factors.
 - Before performing a field calibration, contact customer support to see if there is an alternative. In many cases, field calibrations have a negative effect on measurement accuracy.
-

8.2 Calibration

The flow meter measures process variables based on fixed points of reference. Calibration adjusts those points of reference. Three types of calibration can be performed:

- Zero
- Density calibration
- Temperature calibration

Density and temperature calibration require two data points (low and high) and an external measurement for each. The density and temperature calibration procedure changes the offset and the slope of the line that represents the relationship between process density and the reported density value to the relationship between process temperature and the reported temperature value.

Note

For density or temperature calibration to be useful, the external measurements must be accurate.

Zero calibration requires only that flow through the sensor is stopped.

Flow meters are calibrated at the factory, and normally do not need to be calibrated in the field. Calibrate the flow meter only if you must do so to meet regulatory requirements. Contact customer service before calibrating your flow meter.

Note

Micro Motion recommends using meter validation and meter factors, rather than calibration, to prove the meter against a regulatory standard or to correct measurement error.

8.3 Comparison and recommendations

When choosing among Smart Meter Verification, meter validation, and calibration, consider the following factors:

- Process and measurement interruption
 - Smart Meter verification provides an option that allows process measurement to continue during the test.
 - Meter validation for density does not interrupt the process. However, meter validation for mass flow or volume flow requires process down-time for the length of the test.
 - Calibration requires process down-time. In addition, density and temperature calibration require replacing the process fluid with low-density and high-density fluids, or low-temperature and high-temperature fluids. Zero calibration requires stopping flow through the sensor.
- External measurement requirements
 - Smart Meter Verification does not require external measurements.
 - Zero calibration does not require external measurements.
 - Density calibration, temperature calibration, and meter validation require external measurements. For good results, the external measurement must be three times more accurate than the meter's specified accuracy.
- Measurement adjust
 - Smart Meter Verification is an indicator of sensor condition, but does not change flowmeter internal measurement in any way.
 - Meter validation does not change flowmeter internal measurement in any way. If you decide to adjust a meter factor as a result of a meter validation procedure, only the reported measurement is changed: base measurement is not changed. You can always reverse the change by returning the meter factor to its previous value.
 - Calibration changes the transmitter's interpretation of process data and accordingly changes the base measurement. If you perform a zero calibration and have an 800 enhanced core processor, you can return to the factory zero (or, if using ProLink III, the previous zero). However, if you perform a density calibration or a temperature calibration, you cannot return to the previous calibration factors unless you have manually recorded them.

Micro Motion recommends obtaining the Smart Meter Verification transmitter option and performing Smart Meter Verification on a regular basis.

8.4 Use Smart Meter Verification (SMV)

You can run an SMV test, view and interpret the results, and set up automatic execution.

8.4.1 SMV requirements

To use SMV, the transmitter must be paired with an enhanced core processor.

See [Table 8-1](#) for the minimum version of the transmitter, enhanced core processor, and communication tool needed to support SMV. (If you are going to perform SMV using the display, only the transmitter and enhanced core processor versions apply.)

Table 8-1: Minimum SMV version

Item	Minimum version	Minimum basic SMV transmitter
Transmitter	3.10	4.10
Enhanced core processor	3.6	4.4
ProLink III	1.0	4.0
Siemens Simatic Process Device Manager (PDM) 6.0.	Profibus PA device description: device rev 3.10, DD rev 1	
Siemens Simatic PDM 8.0.2	Profibus PA device description: device rev 3.5, DD rev 1	
Siemens Simatic PDM 8.1	Profibus PA device description: device rev 3.3, DD rev 1	
Siemens Simatic PDM 8.2	Profibus PA device description: device rev 3.5, DD rev 2	
Siemens Simatic PDM 9		Profibus PA device description: device rev 4.10, DD rev 1
Asset Management Software (AMS) 12, 12.3, 12.5	Profibus PA device description: device rev 3.5, DD rev 2	
AMS 13.0		Profibus PA device description: device rev 4.10, DD rev 1

If your devices or tools do not meet the minimum version requirements for SMV, you still may have access to an older version of meter verification if the option was ordered for your transmitter. See [Table 8-2](#) for a description of the major differences between the older meter verification and the newer SMV.

Table 8-2: Major differences between meter verification and SMV

Feature	Meter verification (older)	SMV (newer)
Measurement interruption	Suspended during the test (3 minutes)	No interruption necessary

Table 8-2: Major differences between meter verification and SMV (continued)

Feature	Meter verification (older)	SMV (newer)
Result storage	No results stored in the transmitter	Last 20 results stored in the transmitter (licensed SMV)
Results reporting	Pass/fail/abort	Pass/fail/abort comparison tables and graphs for stored test results ⁽¹⁾
Test start methods	Manual only	Manual, scheduled, event-based

(1) Detailed test analysis such as comparison graphs are not available on the local display.

8.4.2 SMV test preparation

Although it is not necessary to match factory conditions or change the transmitter's configuration during an SMV test, the test will run more smoothly when conditions are stable.

SMV has an output mode called Continuous Measurement that allows the transmitter to keep measuring while the test is in progress. If you choose to run the test in Last Measured Value or Fault modes instead, the transmitter outputs will be held constant for the two minute duration of the test. If control loops depend on transmitter outputs, take appropriate action.

Avoid process instability during the test. If conditions are too unstable, the SMV test will abort. To maximize process stability:

- Maintain a constant fluid pressure and temperature.
- Avoid changes to fluid composition, e.g., two-phase flow or settling.
- Maintain a constant flow rate.

Tip

- The SMV test runs best when flow is stopped through the sensor.
 - SMV is not affected by any configured transmitter parameters for flow, density, or temperature.
-

8.4.3 Run SMV

Run an SMV test using the display

Procedure

1. Navigate to the **Smart Meter Verification** menu.

Figure 8-1: SMV – Top-level menu

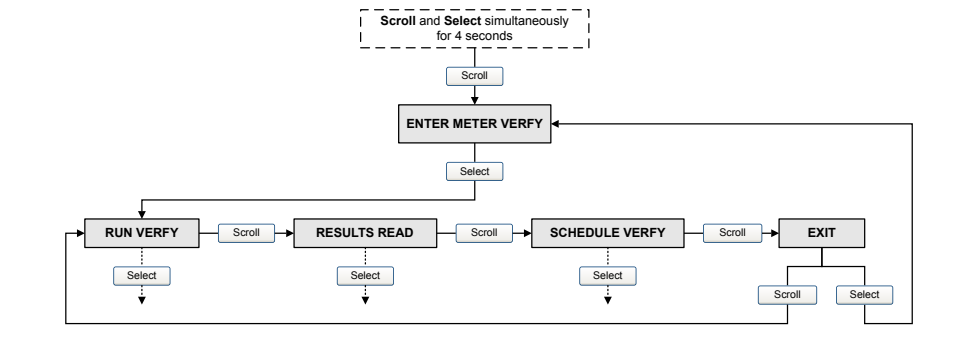

2. Choose **Run Verify**.
3. Choose **Outputs** and select the desired output behavior.

Option	Description
Continue Measuring	During the test, all outputs will continue to report their assigned process variable. The test will run for approximately 90 seconds.
Fault	During the test, all outputs will go to their configured fault action. The test will run for approximately 140 seconds.
Last Value	During the test, all outputs will report the last measured value of their assigned process variable. The test will run for approximately 140 seconds.

While the test is in progress, dots traverse the display and test progress is shown.

Postrequisites

View the test results and take any appropriate actions.

SMV flowchart: Running a test using the display

Figure 8-2: Running an SMV test using the display

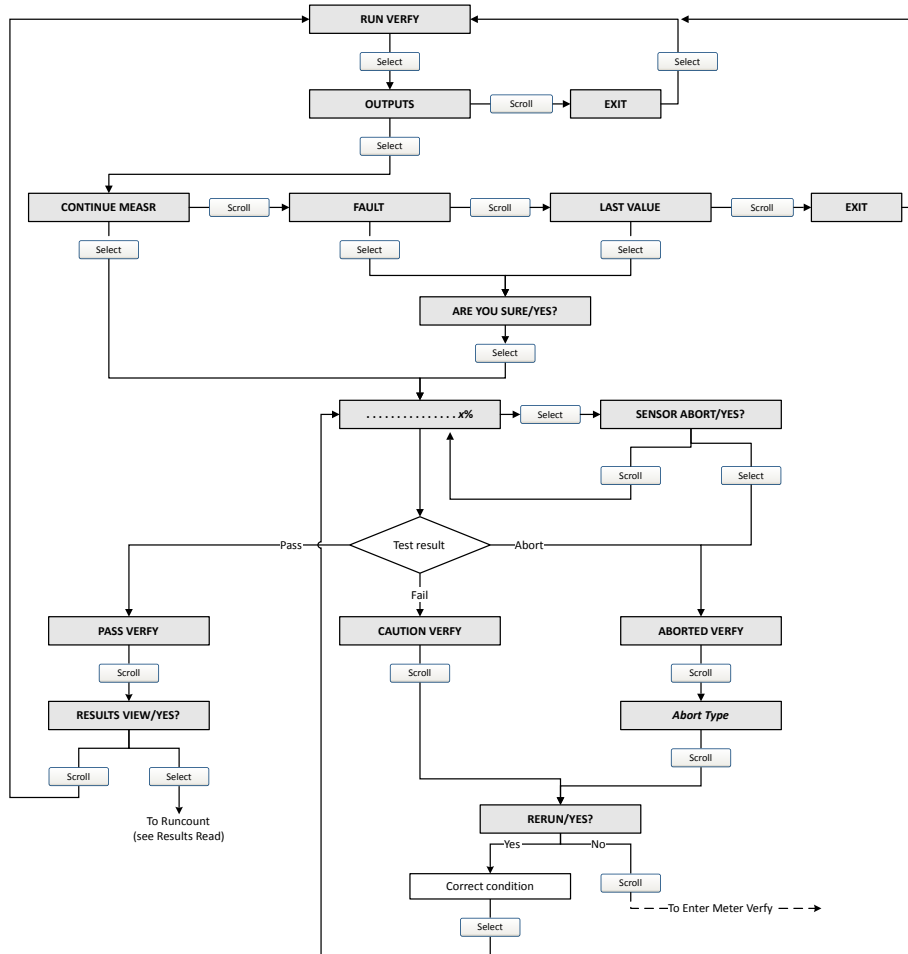

Run an SMV test using ProLink III

Procedure

1. Choose **Device Tools > Diagnostics > Meter Verification > Run Test**.
You may need to wait a few seconds while ProLink III synchronizes its database with the transmitter data.
2. Enter any desired information on the **Test Definition** screen, and click **Next**.
All information on this screen is optional.
3. Choose the desired output behavior.

Option	Description
Continue	During the test, all outputs will continue to report their assigned process variable. The test will run for approximately 90 seconds.

Option	Description
Measuring	
Held at Last Value	During the test, all outputs will report the last measured value of their assigned process variable. The test will run for approximately 140 seconds.
Held at Fault	During the test, all outputs will go to their configured fault action. The test will run for approximately 140 seconds.

4. Press **Start**.
Test progress is displayed on the screen.

Postrequisites

View the test results and take any appropriate actions. You can also print the report.

8.4.4 View test data

You can view the results of the current test. You can also view results from previous tests.

Important

You can view previous test results and see detailed test reports only if SMV is licensed.

The transmitter stores the following information about the previous twenty SMV tests:

- Powered-on hours at the time of the test.
- Test result (Pass, Fail, Abort).
- If the test aborted, 0 is stored for these values.
- Abort code, if applicable.

In addition, ProLink III provides a detailed test reporting and analysis framework. This information is stored on the PC where ProLink III is installed for tests that were run only on that PC. It includes:

- Timestamp from the PC clock
- Current flowmeter identification data
- Current flow and density configuration parameters
- Current zero values
- Current process values for mass flow rate, volume flow rate, density, temperature, and external pressure
- Customer and test descriptions (if entered by the user)

You can use ProLink III to run a test that displays a test result chart and a test report at the completion of the test. On-screen directions are provided to manipulate the test data or export the data to a CSV file for offline analysis.

View test result data using the display

Procedure

1. If you have just run a test, results are displayed automatically at the end of the test.

2. If SMV is licensed, and you want to view results from previous tests:
 - a) Navigate to the **Smart Meter Verification** menu.

Figure 8-3: SMV – Top-level menu

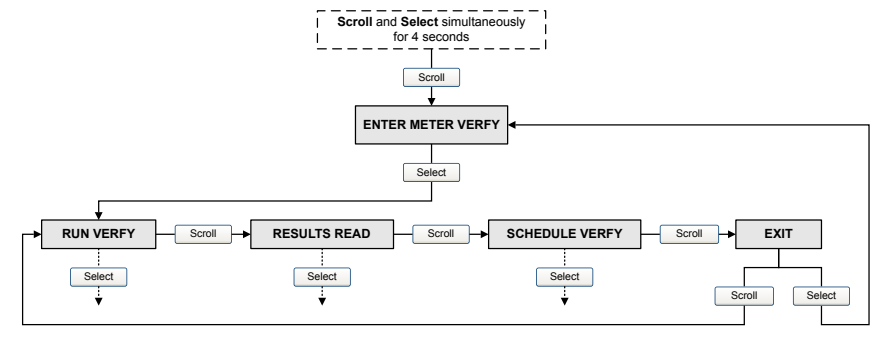

- b) Scroll to **Results Read** and press **Select**.
The runcount of the most recent test is displayed.
- c) To view data for this test, press **Select**, then press **Scroll** to scroll through test data.
- d) To select a different test, press **Scroll**, then press **Select** when the transmitter displays **Results More?**. When the desired test appears, as identified by runcount, press **Select**.

SMV flowchart: Viewing test results using the display

Figure 8-4: Viewing SMV test results using the display

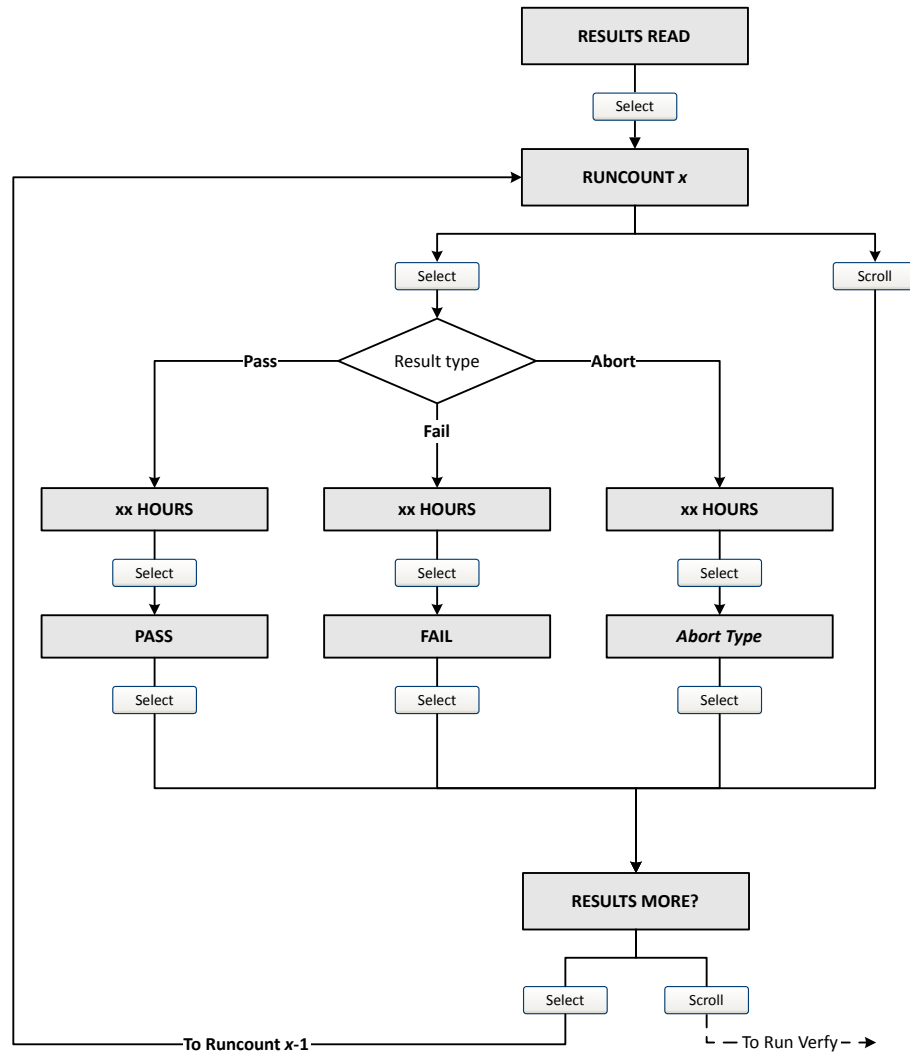

View test result data using ProLink III

Prerequisites

You can view test result data only if your SMV is licensed and only for tests that were run on the PC you are currently using.

Procedure

1. Choose **Device Tools > Diagnostics > Meter Verification** and click **Previous Test Results**.
The chart shows test results for all tests stored in the ProLink III database.
2. (Optional) Click **Next** to view and print a test report.
3. (Optional) Click **Export Data to CSV File** to save the data to a file on your PC.

Understanding SMV results

When the SMV test is completed, the result is reported as Pass, Fail, or Abort. (Some tools report the Fail result as `Advisory` instead.)

Pass Smart Meter Verification does a statistical check between the factory baseline value, field reference point, and the current Smart Meter Verification result. Pass indicates that the two values are statistically the same.

Fail The current SMV value is statistically different than the factory baseline value.

- If the meter passes the second test, the first result can be ignored.
- If the meter fails the second test, the flow tubes may be damaged. Call customer support.

Abort A problem occurred with the meter verification test (such as process instability) or you stopped the test manually. See [Table 8-3](#) for a list of abort codes, a description of each code, and possible actions you can take in response.

Table 8-3: SMV abort codes

Code	Description	Recommended actions
1	User-initiated abort	None required. Wait 15 seconds before starting another test.
2	SMV Timeout	Check status of pickoff and drive coils.
3	Pickoff Voltage Low	Check status of pickoff and drive coils.
4	Temperature unstable	Ensure temperature is stable. Start again.
5	Cal state in progress	NOT AVAILABLE
6	Unused	NOT AVAILABLE
7	Drive loop AGC reported an amplitude error	Check the status of the pickoff and the drive coils.
8	High flow (dt) standard deviation	Reduce the flow rate and start again.
9	High flow (dt) mean value	Reduce the flow rate and start again.
10	State in progress	NOT AVAILABLE
11	Verification Complete	NOT AVAILABLE
12	Transmitter in fault and SMV cannot run	View the Alerts present on the device and take any necessary actions to clear them before proceeding.
13	No factory air verification	Perform factory calibration on air.
14	No factory water verification	Perform a factory calibration on water.
15	Drive frequency drift from carrier frequency	Ensure temperature, flow, and density are stable. Start again.
Other	General abort	Repeat the test. If the test aborts again, contact customer service.

8.4.5 Schedule automatic execution of the SMV test

You can set up and run a single test at a user-defined future time. You can also set up and run tests on a regular schedule.

Manage scheduled test execution using the display

Procedure

1. Navigate to the **Smart Meter Verification** menu.

Figure 8-5: SMV – Top-level menu

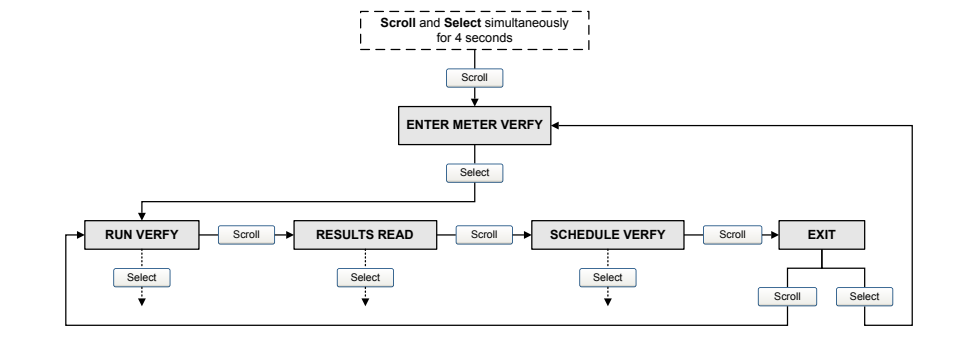

2. Scroll to **Schedule Verify** and press **Select**.
3. To schedule a single test or the first test in recurring execution:
 - a) Scroll to **Set Next** and press **Select**.
 - b) Enter the number of hours that the transmitter will wait before beginning the test.
4. To schedule recurring execution:
 - a) Scroll to **Set Recur** and press **Select**.
 - b) Enter the number of hours that will elapse between tests.
5. To disable scheduled execution:
 - To disable execution of a single scheduled test, set **Set Next** to 0.
 - To disable recurring execution, set **Set Recur** to 0.
 - To disable all scheduled execution, choose **Turn Off Sched** when you enter the **Smart Meter Verification** menu.

SMV flowchart: Scheduling test execution using the display

Figure 8-6: Scheduling SMV test execution using the display

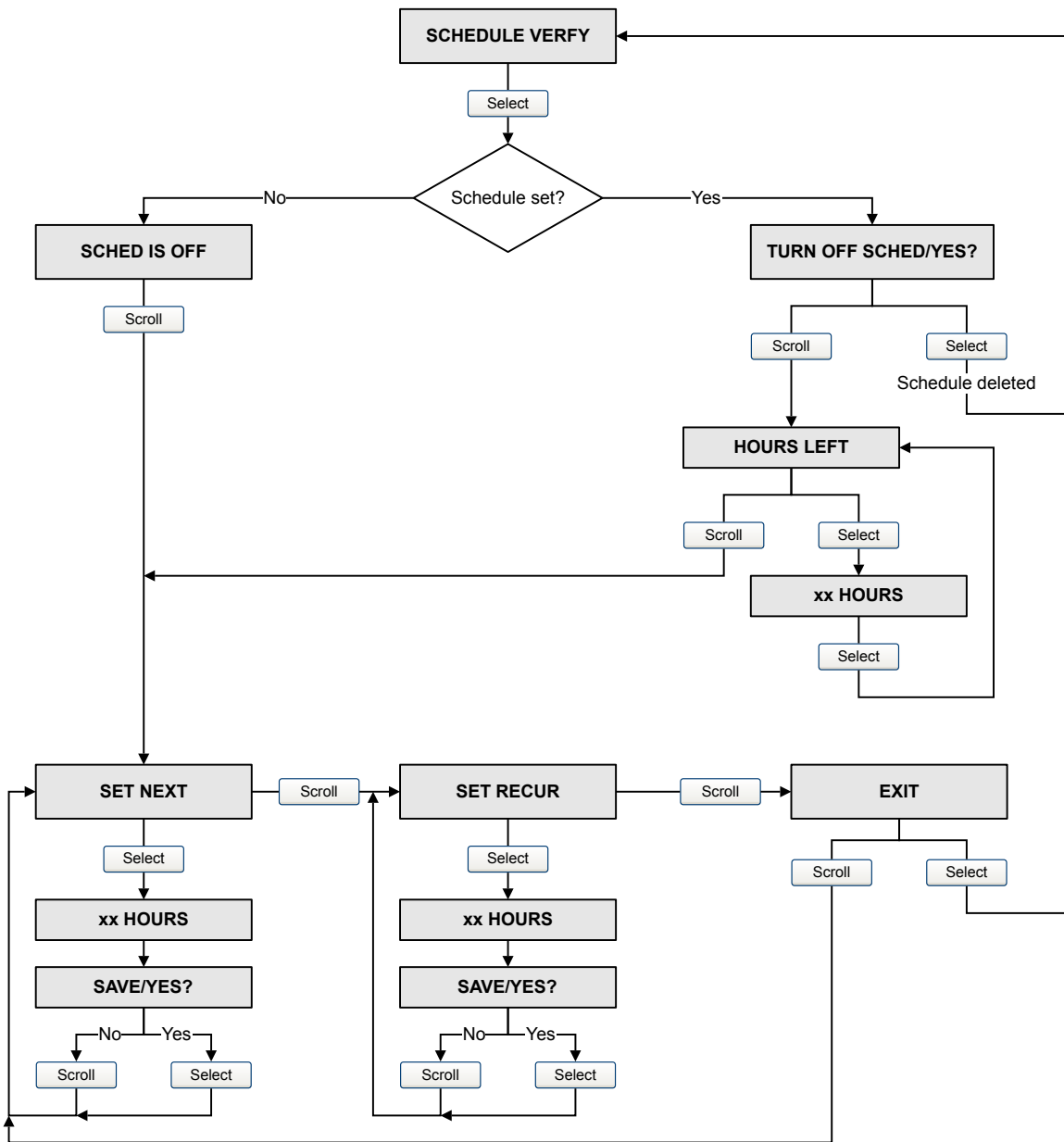

Manage scheduled test execution using ProLink III

Procedure

1. Choose **Device Tools > Diagnostics > Meter Verification > Schedule Meter Verification**.
2. To schedule a single test or the first test in recurring execution, specify a value for **Hours Until Next Run**.

3. To schedule recurring execution, specify a value for **Hours Between Recurring Runs**.
4. To disable scheduled execution:
 - To disable execution of a single scheduled test, set **Hours Until Next Run** to 0.
 - To disable recurring execution, set **Hours Between Recurring Runs** to 0.
 - To disable all scheduled execution, click **Disable Scheduled Execution**.

8.5 Zero the meter

Zeroing the meter establishes a baseline for process measurement by analyzing the sensor's output when there is no flow through the sensor tubes.

Prerequisites

Verify the zero and prepare the meter using the procedures in [Verify the zero](#).

Procedure

Postrequisites

Restore normal flow through the sensor by opening the valves. Verify that the sensor tubes are full.

Need help?

If the zero fails:

- Verify that there is no flow through the sensor, then retry.
 - Remove or reduce sources of electromechanical noise, then retry.
 - Set **Zero Time** to a lower value, then retry.
 - If the zero continues to fail, contact customer service.
-

8.5.1 Performing the zeroing procedure

Before performing the zeroing procedure on a flow meter, you must prepare the flow meter for the process.

About this task

Note

If the zero fails, the meter will be in a fault condition. If you need to clear the fault condition and use the original zero, you can power cycle the transmitter.

Note

Only use this procedure if you have performed zero verification and the result recommends a zero calibration.

To prepare for the zeroing procedure:

Procedure

1. Apply power to the flow meter. Allow the flow meter to warmup up for approximately 20 minutes.

2. Run the process fluid through the sensor until the sensor temperature reaches the normal process operating temperature.
3. Close the shutoff valve downstream from the sensor.
4. Ensure that the sensor is completely filled with fluid and the flow through the sensor has completely stopped.

 **CAUTION**

If fluid is flowing through the sensor, the sensor zero calibration may be inaccurate, resulting in inaccurate process measurement. To improve the sensor zero calibration and measurement accuracy, ensure that process flow through the sensor has completely stopped.

To zero the flow meter, use the appropriate tool at the top of this section and consult the display diagram in [Figure B-10](#).

Display	<ol style="list-style-type: none"> a. From OFF-LINE MAINT, select SWREV > CONFIG > ZERO. b. Select CAL ZERO. c. Select ZERO/YES?. d. Select <p>System responds with either CAL PASS or CAL FAIL .</p>
ProLink III	<ol style="list-style-type: none"> a. Go to Device Tools > Calibration > Zero Verification and Calibration. b. Click Calibrate Zero button. c. If required, modify Zero Time (<div style="background-color: #e0e0e0; padding: 2px; margin: 5px 0;"> Calibration in Progress </div> LED turns red). d. Wait until Calibration in Progress LED turns green. e. If the Calibration Failure LED turns green you are done, but if the LED turns red you need to troubleshoot the cause.
EDD	<ol style="list-style-type: none"> a. Click Modify zero time if desired. b. Click Start Zero Cal. c. Click Execute. d. Click Stop flow through sensor. e. Click OK. f. Click Zero in progress. g. If successful, click Zeroing success, but if unsuccessful, click Troubleshoot.

Bus Parameters	<p>a. Modify zero time (if desired), from Block: Transducer Block 1 (Slot 11)</p> <p style="text-align: center;">Index 83 (zero time)</p> <p>b. Initiate zero from Block: Transducer Block 1 (Slot 11)</p> <p style="text-align: center;">Index 13 (zero calibration)</p> <p>c. Check status from Block: Transducer Block 1 (Slot 11)</p> <p style="text-align: center;">Index 143, Bit 0x8000</p> <p>d. Check for failure alerts from Block: Transducer Block 1 (Slot 11)</p> <p style="text-align: center;">Index 141, Bits 0x0100, 0x0200, 0x0400, and 0x0800</p> <p>e. Check zero value from Block: Transducer Block 1 (Slot 11)</p> <p style="text-align: center;">Index 12 (zero point)</p>
----------------	---

8.6 Meter validation and meter factors

Meter validation compares a measurement value reported by the transmitter with an external measurement standard. Meter validation requires one data point.

Note

For meter validation to be useful, the external measurement standard must be more accurate than the sensor. See the sensor's product data sheet for its accuracy specification.

If the transmitter's mass flow, volume flow, or density measurement is significantly different from the external measurement standard, you may want to adjust the corresponding meter factor. A meter factor is the value by which the transmitter multiplies the process variable value. The default meter factors are 1.0, resulting in no difference between the data retrieved from the sensor and the data reported externally.

Meter factors are typically used for proving the flow meters against a Weights & Measures standard. You may need to calculate and adjust meter factors periodically to comply with regulations.

8.6.1 Performing meter validation

Meter validation compares flow meter measurements reported by the transmitter to an external measurement standard. If the transmitter value for mass flow, volume flow, or

density measurement is significantly different from the external measurement standard, you may want to adjust the corresponding meter factor.

About this task

The flow meter's actual measurement is multiplied by the meter factor, and the resulting value is reported and used in further processing. If using the display, consult the flow chart in [Figure B-5](#).

Display	Menu > MTRF > MASS > VOL > Mass Flow Settings > DENS
ProLink III	<ol style="list-style-type: none"> 1. Select Device Tools > Configuration > Process Measurement > Flow tab 2. Set values for Mass Flow Rate Meter Factor and Volume Flow Rate Meter Factor. 3. Click Apply. 4. Select Device Tools > Configuration > Process Measurement > Density tab 5. Set values for Density Meter Factor. 6. Click Apply.
EDD	<ol style="list-style-type: none"> 1. Select MMI Coriolis Flow > Transducer Block > Measurement > Process Variable. 2. Select Mass Flow > Mass Factor. 3. Select Density > Density Factor. 4. Select Volume Flow > Volume Factor.
Bus Parameters	<ol style="list-style-type: none"> 1. Select Meter Factors > Block: Transducer Block 1 (Slot 11). 2. Choose the appropriate index: Index 36 (Mass factor) <p style="text-align: center;">Index 37 (Density factor)</p> <p style="text-align: center;">Index 38 (Volume factor)</p>

Procedure

1. Determine the meter factor(s) to use. You can set any combination of the mass flow volume flow, and density meter factors.

All three meter factors are independent:

- The mass flow meter factor affects only the value reported for mass flow.
- The density meter factor affects only the value reported for density.
- The volume meter flow affects only the value reported for volume flow.

Therefore, to adjust volume flow, you must set the meter factor for volume flow. Setting a meter factor for mass-flow and a meter factor for density will not produce the desired result. The volume flow calculations are based on original mass flow and density values, before the corresponding meter factors have been applied.

2. Calculate the meter factor as follows:
 - a) Sample the process fluid and record the process variable value reported by the flow meter.

- b) Measure the sample using an external standard.
- c) Calculated the new meter factor using the following formula:

$$\text{NewMeterFactor} = \text{ConfiguredMeterFactor} \times \left(\frac{\text{ExternalStandard}}{\text{ActualFlowmeterMeasurement}} \right)$$

If you are calculating the volume flow meter factor, note that proving volume in the field may be expensive, and the procedure may be hazardous for some process fluids. Therefore, because volume is inversely proportional to density, an alternative to direct sampling and measurement is to calculate the volume flow meter factor from the density meter factor. This method provides partial correction by adjusting for any portion of the total offset that is caused by density measurement offset. Use this method only when a volume flow reference is not available, but a density reference is available.

- d) Calculate the meter factor for density, using the preceding formula.
- e) Calculate the volume flow meter factor from the density meter factor, as shown below:

$$\text{MeterFactor}_{\text{Volume}} = \left(\frac{1}{\text{MeterFactor}_{\text{Density}}} \right)$$

Note

This equation is mathematically equivalent to the equation shown below. You can use whichever equation you prefer.

$$\text{MeterFactor}_{\text{Volume}} = \text{ConfiguredMeterFactor}_{\text{Density}} \times \left(\frac{\text{Density}_{\text{Flowmeter}}}{\text{Density}_{\text{Reference Device}}} \right)$$

- 3. Ensure that the meter factor is between 0.8 and 1.2, inclusive. If the calculated meter factor is outside these limits, contact customer service.

Calculating the meter factor for mass flow

The flow meter is installed and validated for the first time. The mass flow measurement from the transmitter is 250.27 lb. The mass flow measurement from the reference device is 250 lb. The mass flow meter factor is calculated as follows:

$$\text{MeterFactor}_{\text{MassFlow}} = 1 \times \left(\frac{250}{250.27} \right) = 0.9989$$

The first meter factor for mass flow is 0.9989.

One year later, the flow meter is validated again. The mass flow measurement from the transmitter is 250.07 lb. The mass flow measurement from the reference device is 250.25 lb. The new mass flow meter factor is calculated as follows:

$$\text{MeterFactor}_{\text{MassFlow}} = 0.9989 \times \left(\frac{250.25}{250.07} \right) = 0.9996$$

The new meter factor for mass flow is 0.9996.

8.7 Performing density calibration

Density calibration establishes the relationship between the density of the calibration fluids and the signal produced at the sensor. Density calibration includes the calibration of the D1 (low-density) and D2 (high-density) calibration points.

Important

Micro Motion flow meters are calibrated at the factory, and normally do not need to be calibrated in the field. Calibrate the flow meter only if you must do so to meet regulatory requirements. Contact customer service before calibrating the flow meter.

Tip

Micro Motion recommends using meter validation and meter factors, rather than calibration, to prove the meter against a regulatory standard or to correct measurement error.

Density calibration includes the following calibration points:

- All sensors:
 - D1 calibration (low-density)
 - D2 calibration (high-density)
- T-Series sensors only:
 - D3 calibration (optional)
 - D4 calibration (optional)

For T series meters, if the density is outside of 0.8 g/cc and 1.2 g/cc, then a D3 and D4 calibration is recommended to maintain the specified density accuracy of the sensor. If you choose to perform the D3 and D4 calibrations:

- Do not perform the D1 or D2 calibrations
- Perform the D3 calibration if you have one calibrated fluid.
- Perform both the D3 and D4 calibrations if you have two calibrated fluids (other than air and water)

Before performing the calibration, record your current calibration parameters. If you are using ProLink III, you can perform this task by saving the current configuration to a file on the PC. If the calibration fails, restore the known values.

Sensor requirements

During density calibration, the sensor must be completely filled with the calibration fluid, and flow through the sensor must be at the lowest rate allowed by your application. Accomplish this condition by closing the shutoff valve downstream from the sensor, then fill the sensor with the appropriate fluid.

Density calibration fluid requirements

D1 and D2 density calibration require a D1 (low density) fluid and a D2 (high density) fluid. You can use air and water.

Important

For T-Series sensors, the D1 calibration must be performed on air and the D2 calibration must be performed on water.

For D3 density calibration, the D3 fluid must meet the following requirements:

- Minimum density of 0.6 g/cm³
- Minimum difference of 0.1 g/cm³ between the density of the D4 fluid and the density of the D3 fluid. The density of the D4 fluid must be greater than the density of the D3 fluid.
- Minimum difference of 0.1 g/cm³ between the density of the D4 fluid and the density of water. The density of the D4 fluid can be either greater or less than the density of water.

8.7.1 Procedure for calibrating density

You can perform a density calibration using ProLink III, the EDD, or bus parameters.

Procedure

1. Close the shutoff valve that is downstream from the sensor.
2. Uses the appropriate process in the table that follows to perform a density calibration, depending on your communication tool and the particular fluid you are calibrating:

ProLink III D1 density calibration	<p>Device Tools > Calibration > Density Calibration > Point 1 (Air)</p> <ol style="list-style-type: none"> a. Fill the sensor with D1 fluid. b. Enter the density of D1 fluid. c. Press Start Calibration (Displays <i>Calibration in Progress</i> (LED turns yellow)). d. Calibration in Progress (LED turns green). e. LED turns green. f. Close.
ProLink III D2 density calibration	<p>Device Tools > Calibration > Density Calibration > Point 2 (Water)</p> <ol style="list-style-type: none"> a. Fill the sensor with D2 fluid. b. Enter density of D2 fluid. c. Press Start Calibration (Displays <i>Calibration in Progress</i> (LED turns yellow)). d. LED turns green. e. Close.

EDD D1 and D2 density calibration	MMI Coriolis Flow > Calibration > Density Cal a. Fill sensor with D1 fluid. b. D1 = density of D1 fluid. c. Start Lo Density Cal. d. Execute. e. Low Density Cal in progress. f. Fill sensor with D2 fluid. g. D2 = density of D2 fluid. h. Start Hi Density Cal. i. Execute. j. High Density Cal in progress. k. Done.
--	---

<p>Bus Parameters D1 and D2 density calibration</p>	<ul style="list-style-type: none"> a. Fill sensor with D1 fluid. b. Enter the density of the D1 fluid: Block: Transducer Block 1 (Slot 11) Index 97 (D1). c. Initiate D1 calibration: Block: Transducer Block 1 (Slot 11) Index 87 (low density cal) d. Check status: Block: Transducer Block 1 (Slot 11) Index 143, Bit 0x4000) e. Check for failure alerts: Block: Transducer Block 1 (Slot 11) Index 141, Bits 0x0100, 0x0200, and 0x0400 f. Check K1 value: Block: Transducer Block 1 (Slot 11) Index 92 (K1) g. Fill sensor with D2 fluid. h. Enter density of D2 fluid: Block: Transducer Block 1 (Slot 11) Index 98 (D2) i. Initiate D2 calibration: Block: Transducer Block 1 (Slot 11) Index 88 (high density cal) j. Check status: Block: Transducer Block 1 (Slot 11) Index 143, Bit 0x2000) k. Check for failure alerts: Block: Transducer Block 1 (Slot 11) Index 141, Bits 0x0100, 0x0200, and 0x0400 l. Check K2 value: Block: Transducer Block 1 (Slot 11) Index 93 (K2) m. Done.
<p>ProLink III D3 density calibration</p>	<ul style="list-style-type: none"> a. Fill the sensor with D3 fluid. b. Device Tools > Calibration > Density Calibration > Point 3 (T-Series). c. Enter density of the D3 fluid. d. Press Start Calibration (Displays <i>Calibration in Progress</i> (LED turns yellow)). e. LED turns green, f. Close.

<p>ProLink III D4 density calibration</p>	<ol style="list-style-type: none"> a. Fill the sensor with D4 fluid. b. Device Tools > Calibration Data tab c. Enter density of the D4 fluid. d. Press Start Calibration (Displays <i>Calibration in Progress</i> (LED turns yellow)). e. LED turns green, f. Close.
<p>EDD D3 and D4 density calibration</p>	<p>MMI Coriolis Flow > Calibration > T-Series Density Cal</p> <ol style="list-style-type: none"> a. Fill sensor with D3 fluid. b. D3 = density of D3 fluid. c. Start D3 Density Cal. d. Execute. e. D3 Cal in progress. f. Fill sensor with D4 fluid. g. D4 = density of. D4 fluid. h. Start D4 Density Cal. i. Execute. j. D4 Cal in progress. k. Done.

<p>Bus Parameters</p> <p>D3 and D4 density calibration</p>	<ul style="list-style-type: none"> a. Fill sensor with D3 fluid. b. Enter the density of the D3 fluid: Block: Transducer Block 1 (Slot 11) Index 100 (D3) c. Initiate D3 calibration: Block: Transducer Block 1 (Slot 11) Index 90 (D3 cal) d. Check status: Block: Transducer Block 1 (Slot 11) Index 143, Bit 0x0040 e. Check for failure alerts: Block: Transducer Block 1 (Slot 11) Index 141, Bits 0x0100, 0x0200, and 0x0400 f. Check K3 value: Block: Transducer Block 1 (Slot 11) Index 95 (K3) g. Fill sensor with D4 fluid. h. Enter density of D4 fluid: Block: Transducer Block 1 (Slot 11) Index 101 (D4) i. Initiate D4 calibration: Block: Transducer Block 1 (Slot 11) Index 91 (D4 cal) j. Check status: Block: Transducer Block 1 (Slot 11) Index 143, Bit 0x0080 k. Check for failure alerts: Block: Transducer Block 1 (Slot 11) Index 141, Bits 0x0100, 0x0200, and 0x0400 l. Check K4 value: Block: Transducer Block 1 (Slot 11) Index 96 (K4) m. Done.
--	--

Postrequisites

If you disabled **LD Optimization** before the calibration procedure, re-enable it.

9 Troubleshooting

9.1 Guide to troubleshooting topics

This section describes guidelines and procedures for troubleshooting the flowmeter. The information in this section will enable you to:

- Categorize the problem
- Determine whether you are able to correct the problem
- Take corrective measures (if possible)

Note

All procedures provided in this chapter assume that you have established communication with the transmitter and that you are complying with all applicable safety requirements. See [Using the transmitter display](#) or the documentation for your PROFIBUS host or configuration tool.

9.2 Transmitter does not operate

If the transmitter is not receiving power and cannot communicate over the network or display, then perform all of the procedures under [Diagnosing wiring problems](#).

If the wiring checks do not indicate a problem with electrical connections, contact the customer service department.

9.3 Transmitter does not communicate

If the transmitter does not appear to be communicating on the network, then:

- Make sure the PROFIBUS network has proper termination.
- Check the PROFIBUS wiring between the transmitter and the DP/PA coupler, and between the DP/PA coupler and the host system.
- Perform the procedures under [Diagnosing wiring problems](#).
- Make sure the node address is set correctly. The node address is set to a default value of 126 at the factory. Refer to [Setting the node address](#).
- If using a configuration tool such as Simatic PDM, check whether the transmitter shows up in the live devices list.
- Make sure the I/O configuration is set up properly. See [Setting the IO mode](#).

9.4 Function blocks in OOS mode

If all of the transmitter function blocks (AI, AO, and totalizer) are stuck in OOS mode, there may be a fault alert active. The status alerts that will trigger OOS mode are shown in the following table. Refer to [Status alerts](#) for a full description of status alerts and possible remedies.

Table 9-1: OOS mode alerts

Topic	Section
A001	EPROM checksum error
A002	RAM test error (core processor)
A003	Sensor failure (no tube interrupt)
A004	Temperature sensor out-of-range
A005	Input over-range
A008	Density over-range
A014	Transmitter Failure
A016	Line RTD temperature out-of-range
A017	Meter RTD temperature out-of-range
A022	(E)EPROM configuration DB interrupt (core processor)
A023	(E)EPROM totals corrupt (core processor)
A024	(E)EPROM program corrupt (core processor)
A025	Protected boot-sector fault

9.5 Zero or calibration failure

If a zero or calibration procedure fails, the transmitter sends one or more status alerts indicating the cause of failure.

Refer to [Table 9-3](#) for descriptions of status alerts and possible solutions.

9.6 Output problems

Micro Motion suggests that you make a record of the process variables listed below, under normal operating conditions. This will help you recognize when the process variables are unusually high or low.

- Flow rate
- Density
- Temperature
- Tube frequency
- Pickoff voltages (LPO)
- Pickoff voltages (RPO)
- Drive gain

For troubleshooting, check the process variables under both normal flow and tubes-full no-flow conditions. Except for flow rate, you should see little or no change between flow and no-flow conditions. If you see a significant difference, record the values and contact customer service for assistance.

Unusual values for process variables may indicate a variety of different problems. The following table lists several possible problems and remedies.

Table 9-2: Output problems and possible remedies

Symptom	Cause	Possible remedies
No output or incorrect process variable	CHANNEL parameter set incorrectly	Verify the CHANNEL parameter in the AI block matches the correct transducer block measurement channels.
Steady non-zero flow rate under no-flow conditions	Misaligned piping (especially in new installations)	Correct the piping.
	Open or leaking valve.	Check or correct the valve mechanism.
	Bad sensor zero	Rezero the flowmeter. See Zero the meter .
	Bad flow cal factor	Verify characterization. Contact customer service.
Erratic non-zero flow rate under no-flow conditions	Wiring problem	Verify all sensor-to-transmitter wiring and ensure the wires are making good contact. Refer to the installation manual.
	Incorrectly grounded 9-wire cable (only in 9-wire remote and remote core processor with remote transmitter installations)	Verify 9-wire cable installation. Refer to the installation manual.
	Vibration in pipeline at rate close to sensor frequency	Check the environment and remove the source of vibration.
	Leaking valve or seal	Check pipeline.
	Inappropriate measurement unit	Check measurement units using a PROFIBUS host or configuration tool.
	Inappropriate damping value	Check damping. See Damping .
	Two-phase flow (slug flow)	Refer to Damping .
	Plugged flow tube	Check drive gain and frequency. Purge the flow tubes.
	Moisture in sensor junction box (only for 9-wire remote and remote core processor with remote transmitter installations)	Open junction box and allow it to dry. Do not use contact cleaner. When closing, ensure integrity of gaskets and O-rings, and grease all O-rings.

Table 9-2: Output problems and possible remedies (continued)

Symptom	Cause	Possible remedies
	Mounting stress on sensor	Check sensor mounting. Ensure that: <ul style="list-style-type: none"> • Sensor is not being used to support the pipe. • Sensor is not being used to correct misaligned pipe. • Sensor is not too heavy for the pipe.
	Sensor cross-talk	Check environment for sensor with similar (± 0.5 Hz) tube frequency.
	Improper sensor grounding	Check the sensor grounding. Refer to the installation manual.
	Incorrect sensor orientation	Not all orientations work with all process fluids. See the installation manual for your sensor.
Erratic non-zero flow rate when flow is steady	Inappropriate measurement unit	Check measurement units using a PROFIBUS host or configuration tool.
	Inappropriate damping value	Check damping. See Damping .
	Excessive or erratic drive gain	Refer to Checking the core processor .
	Two-phase flow	Refer to Checking two-phase flow (slug flow) .
	Plugged flow tube	Check drive gain and tube frequency. Purge the flow tubes. Sensor may need to be replaced.
	Wiring problem	Verify all sensor-to-transmitter wiring and ensure the wires are making good contact. Refer to the installation manual.
Inaccurate flow rate	Bad flow cal factor	Verify characterization. See Characterization .
	Inappropriate measurement unit	Check measurement units using a PROFIBUS host or configuration tool.
	Bad sensor zero	Rezero the flowmeter. See Zero the meter .
	Bad density calibration factors	Verify characterization. See Characterization .
	Bad flowmeter grounding	Refer to Checking the grounding .
	Two-phase flow (slug flow)	Refer to Checking two-phase flow (slug flow) .
	Wiring problem	Verify all sensor-to-transmitter wiring and ensure the wires are making good contact. Refer to the installation manual.
Inaccurate	Problem with the process fluid	Use standard procedures to check quality of process fluid.

Table 9-2: Output problems and possible remedies (continued)

Symptom	Cause	Possible remedies
density reading	Bad density calibration factors	Verify characterization. See Characterization .
	Wiring problem	Verify all sensor-to-transmitter wiring and ensure the wires are making good contact. Refer to the installation manual.
	Bad flowmeter grounding	See Checking the grounding .
	Two-phase flow (slug flow)	Refer to Checking two-phase flow (slug flow) .
	Sensor cross-talk	Check environment for sensor with similar (± 0.5 Hz) tube frequency.
	Plugged flow tube	Check drive gain and tube frequency. Purge the flow tubes. Sensor may need to be replaced.
Temperature reading significantly different from process temperature	RTD failure	Check for alert conditions and follow troubleshooting procedure for indicated alert.
	Incorrect calibration factors	Perform temperature calibration. Contact customer service.
Temperature reading slightly different from process temperature	Incorrect calibration factors	Confirm that the temperature calibration factor is 1.00000 ± 0.00000 . If there is still an issue, contact customer service.
		Verify characterization. Contact customer service.
Unusually high density reading	Plugged flow tube	Check drive gain and tube frequency. Purge the flow tubes.
	Incorrect K2 value	Verify characterization. Contact customer service.
Unusually low density reading	Two-phase flow (slug flow)	See Checking two-phase flow (slug flow) .
	Incorrect K2 value	Verify characterization. Contact customer service.

Table 9-2: Output problems and possible remedies (continued)

Symptom	Cause	Possible remedies
Unusually high tube frequency	Sensor erosion	Contact customer service.
Unusually low tube frequency	Plugged flow tube	Check drive gain and tube frequency. Purge the flow tubes. Sensor may need to be replaced.
Unusually low pickoff voltages	Several possible causes	See Low pickoff voltage .
Unusually high drive gain	Several possible causes	See Excessive drive gain .

Damping

An incorrectly set damping value may make the transmitter's output appear too sluggish or too jumpy. Adjust the damping parameters in the transducer block to achieve the damping effect you want. See [Changing the damping values](#).

If the transmitter appears to be applying damping values incorrectly or the damping effects do not appear to be changed by adjustments to the damping parameters, then the AI PV Filter Time parameter in an AI function block may be improperly set. Inspect each AI function block, and ensure that AI PV Filter Time is set to zero.

Low-flow cutoff

If the transmitter is sending an output of zero unexpectedly, then one of the low-flow cutoff parameters may be set incorrectly. Verify that the cutoff parameters in the transducer block are set to appropriate levels. If there are constant low flow readings when there is no flow, the Low-Flow cutoff is set too low. Increase the setting to two times the flow value in a no flow condition.

See [Configuring cutoffs](#).

Output scale

An incorrectly configured output scale can cause the transmitter to report unexpected output levels. Verify that the AI Out Scale values are set up correctly for each AI block. See [Changing the output scale](#).

Characterization

Incorrect characterization parameters can cause the transmitter to send unexpected output values. However, you should suspect an incorrect characterization only if the transmitter and sensor have recently been paired together for the first time.

Calibration

Improper calibration may cause the transmitter to send unexpected output values. However, you should suspect an improper calibration only if the transmitter has been field-calibrated recently. Refer to [Performing the zeroing procedure](#) and [Performing density calibration](#) for more information about calibration.

Note

Use meter factors, rather than calibration, to prove the meter against a regulatory standard or to correct measurement error. Contact customer service before calibrating your flowmeter. Refer to [Performing meter validation](#) for information about meter factors.

9.7 Status alerts

Status alerts are reported by a PROFIBUS host, the display, and ProLink III software. Remedies for the alert states appear below. Some status alerts cause all of the function blocks (AI, AO, and totalizer) to change to OOS mode.

Table 9-3: Status alerts and remedies

Display code	Description	Possible remedies
A001	EEPROM checksum	Cycle power to the transmitter. If a power cycle does not clear the A001 alert, then the memory is corrupt and the transmitter needs to be replaced.
		The flowmeter might need service. Contact customer service.
A002	RAM error	Cycle power to the transmitter. If a power cycle does not clear the A001 alert, then the memory is corrupt and the transmitter needs to be replaced. If the memory is bad, the A002 alert might take as long as 15 minutes to reappear.
		The flowmeter might need service. Contact customer service.
A003	Sensor failure	Check the diagnostic variables. See Obtaining and checking the diagnostic variables .
		Check the sensor coils. See Checking sensor coils and RTD .
		Check wiring to the sensor. See Checking the sensor-to-transmitter wiring .
		Check for two-phase flow (slug flow). See Checking two-phase flow (slug flow) .
		Check sensor tubes.

Table 9-3: Status alerts and remedies (continued)

Display code	Description	Possible remedies
A004	Temperature overrange	Check the diagnostic variables. See Obtaining and checking the diagnostic variables .
		Check the sensor coils. See Checking sensor coils and RTD .
		Check wiring to the sensor. See Checking the sensor-to-transmitter wiring .
		Verify process temperature range is within limits for the sensor and the transmitter.
		Contact customer service.
A005	Input overrange	Check the diagnostic variables. See Obtaining and checking the diagnostic variables .
		Check the sensor coils. See Checking sensor coils and RTD .
		Verify process conditions.
		Verify that transmitter is configured to use appropriate measurement units. See Changing the measurement units .
		Verify flowmeter characterization. See Characterization .
		Re-zero the flowmeter. See Zero the meter .
A006	Transmitter not configured	Check the characterization. Specifically, verify the FCF and K1 values.
		Contact customer service.
A008	Density overrange	Verify flowmeter characterization. See Characterization .
		Check the diagnostic variables. See Obtaining and checking the diagnostic variables .
		Check the sensor coils. See Checking sensor coils and RTD .
		Check for air in the flow tubes, tubes not filled, foreign material in the tubes, or coating in the tubes.
A009	Transmitter initializing or warming up	Allow the transmitter to warm up. The error should disappear from the status words once the transmitter is ready for normal operation. If alert does not clear, make sure the sensor is either completely full or completely empty. Verify both the sensor configuration and the transmitter wiring to the sensor (refer to the installation manual).
A010	Calibration failure	If an alert appears during zero, ensure there is no flow through the sensor, then retry.

Table 9-3: Status alerts and remedies (continued)

Display code	Description	Possible remedies
		Cycle power to the flowmeter, then retry.
A011	Calibration too low	Ensure there is no flow through the sensor, then retry.
		Cycle power to the flowmeter, then retry.
A012	Calibration too high	Ensure there is no flow through the sensor, then retry.
		Cycle power to the flowmeter, then retry.
A013	Zero too noisy	Remove or reduce sources of electromechanical noise, then attempt the calibration or zero procedure again. Possible sources of noise include: <ul style="list-style-type: none"> • Mechanical pumps • Electrical interference • Vibration effects from nearby machinery
		Cycle power to the flowmeter, then retry.
A014	Transmitter failed	Cycle power to the flowmeter, then retry.
		The transmitter might need service. Contact customer service.
A016	Line Temp out-of-range	Check the diagnostic variables. See Obtaining and checking the diagnostic variables .
		Check the sensor coils. See Checking sensor coils and RTD .
		Check wiring to the sensor. See Checking the sensor-to-transmitter wiring .
		Verify flowmeter characterization. See Characterization .
		Contact customer service.
A017	Meter RTD temperature out-of-range	Check the diagnostic variables. See Obtaining and checking the diagnostic variables .
		Check the sensor coils. See Checking sensor coils and RTD .
		Contact customer service.
A018	EEPROM Error (Transmitter)	The flowmeter might need service. Contact customer service.
A020	Calibration factors unentered	Check the characterization. Specifically, verify the FCF value.

Table 9-3: Status alerts and remedies (continued)

Display code	Description	Possible remedies
A021	Incorrect sensor type	Check the characterization. Specifically, verify the K1 value.
A022	Configuration corrupt	The flowmeter needs service. Contact customer service.
A023	Totals corrupt	The flowmeter needs service. Contact customer service.
A024	CP program corrupt	The flowmeter needs service. Contact customer service.
A025	Boot sector failed	Cycle power to the meter.
		The transmitter might need service. Contact customer service.
A026	Sensor/transmitter communication failure	Check wiring between transmitter and core processor (see Checking the sensor-to-transmitter wiring). The wires may be swapped. After swapping wires, cycle power to the flowmeter.
		Check for noise in wiring or transmitter environment.
		Check the core processor Checking the core processor .
		Perform the core processor resistance test. See Performing the core processor resistance test .
A028	Sensor/transmitter write failure	Cycle power to the meter.
		The flowmeter needs service. Contact customer service.
A030	Hardware/software incompatible	The loaded software is not compatible with the programmed board type. Contact customer service.
A031	Low Power	The core processor is not receiving enough power. Check the power supply to the transmitter, and check power wiring between the transmitter and the core processor (4-wire remote installations only).
A032	Smart Meter Verification in progress	Allow the procedure to complete.

Table 9-3: Status alerts and remedies (continued)

Display code	Description	Possible remedies
	and outputs fixed	If desired, abort the procedure and restart with outputs set to Continue Measurement. The flowmeter needs service. Contact customer service.
A033	Sensor OK / Tubes Stopped by Process	No signal from LPO or RPO, suggesting that sensor tubes are not vibrating. Verify process. Check for air in the flow tubes, tubes not filled, foreign material in tubes, or coating in tubes.
A034	Smart Meter Verification failed	Rerun the test. If the test fails again, see Understanding SMV results .
A035	Smart Meter Verification aborted	If desired, read the abort code. See Understanding SMV results , and perform the appropriate action.
A102	Drive overrange	Excessive or erratic drive gain. See Checking the core processor . Check the sensor coils. See Checking sensor coils and RTD .
A103	Data loss possible	Cycle power to the transmitter. The transmitter might need service. Contact customer service.
A104	Calibration in progress	Allow the flowmeter to complete calibration.
A105	Slug flow	Allow two-phase flow (slug flow) to clear from the process. See Checking two-phase flow (slug flow) .
A106	Function block is in simulation mode	Disable function block simulation.
A107	Power reset occurred	No action is necessary.
A116	API temperature	Verify process.

Table 9-3: Status alerts and remedies (continued)

Display code	Description	Possible remedies
	outside standard range	Verify API reference table and temperature.
A117	API density out of limits	Verify process.
		Verify API reference table and temperature.
A120	Concentration measurement: unable to fit curve data	Verify enhanced density configuration.
A121	Concentration measurement: extrapolation alert	Verify process temperature.
		Verify process density.
		Verify enhanced density configuration.
A131	Smart Meter Verification in progress	Allow the procedure to complete.
		If desired, abort the procedure and restart with outputs set to Fault.
A132	Simulation mode active	Disable sensor simulation mode. See Using sensor simulation mode .

9.8 Diagnosing wiring problems

Use the procedures in this section to check the transmitter installation for wiring problems. Installation procedures are provided in the manual entitled *Model 2700 Transmitters: Installation Manual*.

 **WARNING**

Removing the wiring compartment covers in explosive atmospheres while the power is on can cause an explosion. Before removing the field wiring compartment cover in explosive atmospheres, shut off the power and wait five minutes.

Checking the power-supply wiring

To check the power-supply wiring:

1. Verify that the correct external fuse is used. An incorrect fuse can limit current to the transmitter and keep it from initializing.
2. Power down the transmitter.
3. If the transmitter is in a hazardous area, wait five minutes.
4. Ensure that the power supply wires are connected to the correct terminals. Refer to the installation manual.
5. Verify that the power-supply wires are making good contact and are not clamped to the wire insulation.
6. Inspect the voltage label on the inside of the field-wiring compartment. Verify that the voltage supplied to the transmitter matches the voltage specified on the label.
7. Use a voltmeter to test the voltage at the transmitter's power supply terminals. Verify that it is within specified limits. For DC power, you may need to size the cable. Refer to the installation manual for information about the transmitter power supply.

Checking the sensor-to-transmitter wiring

Note

This does not apply to flow meters with an integrally-mounted transmitter.

To check the sensor-to-transmitter wiring, verify that:

- The transmitter is connected to the sensor according to the wiring information provided in the installation manual.
- The wires are making good contact with the terminals.
- For 4-wire connections, the mating connector between the core processor and the transmitter is securely plugged into its socket.

If the wires are incorrectly connected:

1. Power down the transmitter.
2. Wait five minutes before opening the transmitter compartment if the transmitter is in a hazardous area.
3. Correct the wiring.
4. Restore power to the transmitter.

Checking the grounding

The sensor and the transmitter must be grounded. If the core processor is installed as part of the transmitter or the sensor, it is grounded automatically. If the core processor is installed separately, it must be grounded separately. Refer to the installation manual.

Checking the communication wiring

To check the communication wiring, verify that:

- Communication wires and connections meet PROFIBUS wiring standards.
- Wires are connected according to instructions provided in the installation manual.
- Wires are making good contact with the terminals.

9.9 Checking two-phase flow (slug flow)

The dynamics of two-phase flow are described in [Changing two-phase flow \(slug flow\) limits and duration](#). If the transmitter is reporting a two-phase (slug flow) alert, first check the process and possible mechanical causes for the alert:

- Actual changes in process density
- Cavitation or flashing
- Leaks
- Sensor orientation — sensor tubes should normally be down when measuring liquids, and up when measuring gases. Refer to the sensor documentation for more information about orientation.

If there are no mechanical causes for the two-phase (slug flow) alert, the slow flow limits and duration may be set too high or too low. The high limit is set by default to 5.0 g/cm^3 , and the low limit is set by default to 0.0 g/cm^3 . Lowering the high limit or raising the low limit will cause the transmitter to be more sensitive to changes in density. If you expect occasional two-phase flow in your process, you may need to increase the two-phase flow duration. A longer two-phase flow duration will make the transmitter more tolerant of two-phase flow.

9.10 Obtaining and checking the diagnostic variables

You can diagnose sensor failure or overrange status alerts by checking the flowmeter diagnostic variables. The diagnostic variables include left and right pickoff voltages, drive gain, and tube frequency. You can obtain the diagnostic variables with the PROFIBUS EDD, the PROFIBUS bus parameters, or ProLink III.

With PROFIBUS EDD

To obtain the diagnostic variables, select **View > Diagnostics > Meter Diagnostic**. Record the LPO AMplitude, RPO AMplitude, Drive Gain, and Tube Frequency values.

With PROFIBUS bus parameters

To obtain the diagnostic variables, examine the indices listed in the following table.

Table 9-4: Bus parameter diagnostic variables

Slot	Index	Description
11	160	Drive gain
11	161	Tube frequency
11	163	LPO amplitude
11	164	RPO amplitude

With ProLink III

To obtain the diagnostic variables with ProLink III, enter the main window or select **Device Tools > Diagnostic > Core Processor Diagnostics**. Record the Left Pickoff, Right Pickoff, Drive Gain, and Tube Frequency values.

Evaluating the diagnostic variables

Use the following guidelines to evaluate the diagnostic variables:

- If the drive gain is at 100%, refer to [Excessive drive gain](#).
- If the drive gain is unstable, refer to [Erratic drive gain](#).
- If the value for the left or right pickoff does not equal the appropriate value from [Table 9-5](#), based on the sensor flow tube frequency, refer to [Low pickoff voltage](#).
- If the values for the left and right pickoffs equal the appropriate values from the following table, based on the sensor flow tube frequency, contact customer service for assistance.

Table 9-5: Sensor pickoff values

Sensor model ⁽¹⁾	Pickoff value
ELITE Model CMF sensors	3.4 m peak to peak per Hz based on flow tube frequency
Model CMF 400 I.S	2.7 m peak to peak per Hz based on flow tube frequency
Model CMF 400 with booster amplifier	3.4 m peak to peak per Hz based on flow tube frequency
Model D, DL, and DT sensors	3.4 m peak to peak per Hz based on flow tube frequency
Model F025, F050, and F100 sensors	3.4 m peak to peak per Hz based on flow tube frequency
Model F200 sensors	2.0 m peak to peak per Hz based on flow tube frequency
Model H025, H050, or H100 sensor	3.4 m peak to peak per Hz based on flow tube frequency

Table 9-5: Sensor pickoff values (continued)

Sensor model ⁽¹⁾	Pickoff value
Model H200 sensor	2.0 m peak to peak per Hz based on flow tube frequency
Model R025, R050, or R100 sensor	3.4 m peak to peak per Hz based on flow tube frequency
Model R200 sensor	2.0 m peak to peak per Hz based on flow tube frequency
Micro Motion T-Series Sensors	0.5 m peak to peak per Hz based on flow tube frequency

(1) If your sensor model is not listed, contact customer service.

Excessive drive gain

The causes and possible solutions of excessive drive gain are listed in the following table.

Table 9-6: Excessive drive gain causes and solutions

Cause	Solution
Gas bubbles in a liquid flow or slugs of liquid in a gas flow.	Check for gas in a liquid flow.
Plugged flow tube	Purge the flow tubes. Sensor may need to be replaced.
Excessive two-phase flow	Eliminate slugs.
	Change the sensor orientation.
Cavitation or flashing	Increase inlet or back pressure at the sensor.
	If a pump is located upstream from the sensor, increase the distance between the pump and sensor.
Drive board or module failure, cracked flow tube, or sensor imbalance	Contact customer service.
Mechanical binding at the sensor	Ensure sensor is free to vibrate.
Open drive or left pickoff sensor coil	Contact customer service.
Flow rate out of range	Ensure flow rate is within sensor limits.
Incorrect sensor characterization	Verify characterization.

Erratic drive gain

The causes and possible solutions of erratic drive gain are listed in the following table.

Table 9-7: Erratic drive gain causes and solutions

Cause	Solution
Wrong K1 characterization constant for sensor	Re-enter the K1 characterization constant.
Polarity of pick-off reversed or polarity of drive reversed	Contact customer service.
two-phase flow	Verify flow tubes are completely filled with process fluid, and that two-phase flow limits and duration are properly configured. See Changing two-phase flow (slug flow) limits and duration .
Foreign material caught in flow tubes	Purge flow tubes. Sensor may need to be replaced.

Low pickoff voltage

The causes and possible solutions of low pickoff voltage are listed in the following table,

Table 9-8: Low pickoff voltage causes and solutions

Cause	Solution
Faulty wiring runs between the sensor and core processor	Refer to the sensor manual and transmitter installation manual.
Two-phase flow	Verify the flow tubes are completely filled with process fluid, and that two-phase flow limits and duration are properly configured. See Changing two-phase flow (slug flow) limits and duration .
No tube vibration in sensor	Check for plugging.
	Ensure sensor is free to vibrate (no mechanical binding).
	Verify the wiring.
	Test coils at sensor. See Checking sensor coils and RTD .
Moisture in the sensor electronics	Eliminate the moisture in the sensor electronics.
The sensor is damaged	Contact customer service.

9.11 Checking the core processor

Two core processor procedures are available:

- You can check the core processor LED. The core processor has an LED that indicates different flowmeter conditions.
- You can perform the core processor resistance test to check for a damaged standard core processor. The resistance test does not apply to the enhanced core processor.

For both tests you will need to expose the core processor.

Exposing the core processor

Follow these procedures to expose the core processor

1. Determine your installation type. Refer to [Flow meter installation types and components](#).
2. If you have a 4-wire remote installation or a remote core processor with remote transmitter installation, remove the core processor lid. The core processor is intrinsically safe and can be opened in all environments.
3. If you have an integral installation:
 - a. Loosen the four cap screws that fasten the transmitter to the base ([Figure 9-1](#)).
 - b. Rotate the transmitter counter-clockwise so that the cap screws are in the unlocked position.
 - c. Gently lift the transmitter straight up, disengaging it from the cap screws. Do not disconnect or damage the wires that connect the transmitter to the core processor.
4. If you have a 9-wire remote installation:
 - a. Remove the end-cap.
 - b. Inside the core processor housing, loosen the three screws that hold the core processor mounting plate in place. Do not remove the screws. Rotate the mounting plate so that the screws are in the unlocked position.
 - c. Holding the tab on the mounting plate, slowly lower the mounting plate so that the top of the core processor is visible. Do not disconnect or damage the wires that connect the core processor to the transmitter.

Figure 9-1: Integral installation components

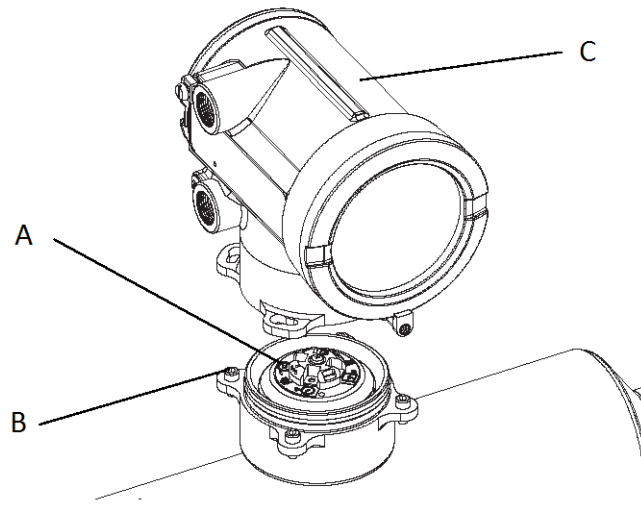

- A. Core processor
- B. 4 x cap screws
- C. Transmitter

When reassembling components, take care not to pinch or stress the wires. Grease all O-rings.

Checking the core processor LED

Do not shut off power to the transmitter when checking the core processor LED. To check the core processor LED:

1. Expose the core processor according to the instructions in [Exposing the core processor](#).
2. Check the core processor LED against the conditions listed in [Table 9-9](#) or [Table 9-10](#).

Table 9-9: Standard core processor LED behavior, flowmeter conditions, and remedies

LED behavior	Condition	Possible remedy
1 flash per second (75% off, 25% on)	Normal operation	No action required
1 flash per second (25% off, 75% on)	Two-phase flow (Slug flow)	See Restoring a working configuration .
Solid on	Zero or calibration in progress	If zero or calibration procedure is in progress, no action is required. If these procedures are not in progress, contact customer service.

Table 9-9: Standard core processor LED behavior, flowmeter conditions, and remedies (continued)

LED behavior	Condition	Possible remedy
	Core processor receiving between 11.5 and 5 volts	Check power supply to transmitter. See Checking the power-supply wiring .
3 rapid flashes followed by a pause	Sensor not recognized	Check wiring between transmitter and sensor (9-wire remote installation or remote core processor with remote transmitter installation). Refer to the installation manual.
	Improper configuration	Verify characterization.
	Broken pin between sensor and core processor	Contact customer service.
4 flashes per second	Fault condition	Check alert status.
OFF	Core processor receiving less than 5 volts	Verify power supply wiring to core processor. Refer to the installation manual.
		If status LED is lit, transmitter is receiving power. Check voltage across terminals 1 (VDC+) and 2 (VDC-) in core processor. Normal reading is approximately 14 VDC. <ul style="list-style-type: none"> If reading is normal, internal core processor failure is possible — contact customer service. If reading is 0, internal transmitter failure is possible — contact customer service. If reading is less than 1 VDC, verify power supply wiring to core processor. Wires may be switched. Refer to the installation manual.
		If status LED is not lit, transmitter is not receiving power. Check power supply. If power supply is operational, internal transmitter, display, or LED failure is possible. Contact customer service.
	Core processor internal failure	Contact customer service.

Table 9-10: Enhanced core processor LED behavior, flowmeter conditions, and remedies

LED behavior	Condition	Possible remedy
Solid green	Normal operation.	No action required.
Flashing yellow	Zero in progress	No action required. If calibration is in progress, no action required. If no calibration is in progress, contact Micro Motion.
Solid yellow	Low severity alert	Check alert status.
Solid red	High severity alert	Check alert status.
Flashing red (80% on, 20% off)	Tubes not full	If alert A105 (two-phase (slug flow)) is active, see Checking two-phase flow (slug flow) .
		If alert A033 (tubes not full) is active, verify process. Check for air in the flow tubes, tubes not filled, foreign material in tubes, or coating in tubes.
Flashing red (50% on, 50% off)	Electronics failed	Contact customer service.
Flashing red (50% on, 50% off, skips every 4th)	Sensor failed	The LPO, RPO, or drive circuit wires might not be connected. Refer to Diagnosing wiring problems .
Solid red	High severity alert	Check alert status.

Performing the core processor resistance test

To perform the core processor resistance test:

1. Disconnect power to the transmitter and core processor.
2. Expose the core processor according to the instructions in [Exposing the core processor](#).
3. Measure the resistance across the following terminal pairs (standard core processor only):
 - The resistance across terminals 3 and 4 (RS-485A and RS-485B) should be 40–50 kilo-ohms.
 - The resistance across terminals 2 and 3 (VDC– and RS-485A) should be 20–25 kilo-ohms.
 - The resistance across terminals 2 and 4 (VDC– and RS-485B) should be 20–25 kilo-ohms.

If any of the resistance measurements are lower than specified, the core processor may not be able to communicate with a transmitter or remote host. Contact customer service.

9.12 Checking sensor coils and RTD

Problems with sensor coils can cause several alerts, including sensor failure and a variety of out-of-range conditions. Checking the sensor coils involves testing the terminal pairs and testing for shorts to the case.

9-wire remote or remote core processor with remote transmitter installation

If you have a 9-wire remote or a remote core processor with remote transmitter installation:

1. Power down the transmitter.
2. If the transmitter is in a hazardous area, wait five minutes.
3. Remove the end-cap from the core processor housing.
4. Unplug the terminal blocks from the terminal board.
5. Using a digital multimeter (DMM), check the circuits listed in [Table 9-11](#) by placing the DMM leads on the unplugged terminal blocks for each terminal pair.
6. There should be no open circuits (that is, no infinite resistance readings). The LPO and RPO readings should be the same or very close (± 5 ohms). If there are any unusual readings, repeat the coil measurement tests at the sensor junction box to eliminate the possibility of faulty cable. The readings for each coil pair should match at both ends.
7. If the cable is faulty, replace the cable.
8. Leave the core processor terminal blocks disconnected. At the sensor, remove the lid of the junction box and test each sensor terminal for a short to case by placing one DMM lead on the terminal and the other lead on the sensor case. With the DMM set to its highest range, there should be infinite resistance on each lead. If there is any resistance at all, there is a short to the case.
9. Test the terminal pairs as follows:
 - Brown against all other terminals except Red
 - Red against all other terminals except Brown
 - Green against all other terminals except White
 - White against all other terminals except Green
 - Blue against all other terminals except Gray
 - Gray against all other terminals except Blue
 - Orange against all other terminals except Yellow and Violet
 - Yellow against all other terminals except Orange and Violet
 - Violet against all other terminals except Yellow and Orange

Note

D600 sensors and CMF400 sensors with booster amplifiers have different terminal pairs. Contact customer service for assistance.

There should be infinite resistance for each pair. If there is any resistance at all, there is a short between terminals.

10. See [Table 9-12](#) for possible causes and solutions.
11. If the problem is not resolved, contact customer service.

Note

When reassembling the meter components, be sure to grease all O-rings.

Table 9-11: Circuit terminal pairs

Circuit	Test terminal pair
Drive coil	Brown to red
Left pickoff coil (LPO)	Green to white
Right pickoff coil (RPO)	Blue to gray
Resistance temperature detector (RTD)	Yellow to violet
Lead length compensator (LLC) (All sensors except CMF400 IS and T-Series) Composite RTD (T-Series only) Fixed resistor (CMF400 IS only)	Yellow to orange

Table 9-12: Sensor and cable short to case possible causes and remedies

Possible cause	Solution
Moisture inside the sensor junction box	Make sure that the junction box is dry and no corrosion is present.
Liquid or moisture inside the sensor case	Contact customer service.
Internally shorted feedthrough (sealed passage for wiring from sensor to sensor junction box)	Contact customer service.
Faulty cable	Replace cable.
Improper wire termination	Verify wire terminations inside sensor junction box. See either the Micro Motion 9-Wire Flowmeter Cable Preparation and Installation Guide or the sensor documentation.

9.12.1 4-wire remote or integral installation

About this task

If you have a 4-wire remote installation or an integral installation, use the following procedure

Procedure

1. Power down the transmitter.

Note

If the transmitter is in a hazardous environment, wait five minutes.

2. If you have a 4-wire remote installation, remove the core processor lid.
3. If you have an integral installation:
 - a) Loosen the four cap screws that fasten the transmitter to the base (refer to Figure 6-1).

- b) Rotate the transmitter counter-clockwise so that the cap screws are in the unlocked position.
- c) Gently lift the transmitter straight up, disengaging it from the base.

Note

You have the option of disconnecting the 4-wire cable or leaving it connected.

4. Determine whether you have a standard or an enhanced core processor:
 - If you have a standard core processor, loosen the captive screw (2,5 mm) at the center of the core processor. Carefully remove the core processor from the sensor by grasping it and lifting it straight up.



CAUTION

Do not twist or rotate the core processor.

- If you have an enhanced core processor, loosen the two captive screws (2,5 mm) that hold the core processor in the housing. Gently lift the core processor out of the housing, then disconnect the sensor cable from the feedthrough pins.



CAUTION

Do not damage the feedthrough pins.



CAUTION

If the core processor (feedthrough) pins are bent, broken, or damaged in any way, the core processor will not operate. Do not twist or rotate the core processor when lifting it. When replacing the core processor (or sensor cable) on the pins, be sure to align the guide pins and mount the core processor (or sensor cable) carefully.

5. Use a digital multimeter (DMM) to check the resistance across the right and left pickoff coils. See [Figure 9-2](#). Neither pair should be an open circuit (infinite resistance). The resistance values should be the same or very close (± 5 ohms).
6. Use the DMM to check the resistance across the RTD and LLC (lead length compensation) circuits. See [Figure 9-2](#). Neither pair should be an open circuit (infinite resistance).
7. Test for a ground to case by checking the resistance between each pin and the sensor case. With the DMM set to its highest range, there should be infinite resistance on each lead. If there is any resistance at all, there is a short to case.
If a short to case is indicated, check for moisture or corrosion. If you are unable to determine the source of the problem, contact customer service.
8. Test for shorts across terminals by testing resistance across the following terminal pairs (see [Figure 9-2](#) and [Figure 9-3](#)). There should be infinite resistance in each case. If there is any resistance at all, there is a short between the terminals.
 - Brown against all other terminals except Red
 - Red against all other terminals except Brown
 - Green against all other terminals except White
 - White against all other terminals except Green
 - Blue against all other terminals except Gray
 - Gray against all other terminals except Blue

- Orange against all other terminals except Yellow and Violet
- Yellow against all other terminals except Orange and Violet
- Violet against all other terminals except Yellow and Orange

Figure 9-2: Sensor pins -- Standard core processor

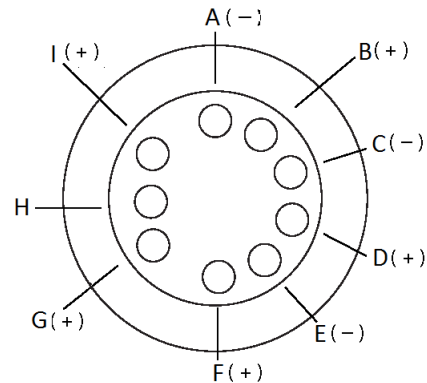

- A. Right pickoff (negative)
- B. Right pickoff (positive)
- C. Left pickoff (negative)
- D. Left pickoff (positive)
- E. Drive (negative)
- F. Drive (positive)
- G. Resistance temperature detector (positive)
- H. Resistance temperature detector return / Lead length compensator (common)
- I. Lead length compensator⁽¹⁾

Note

D600 sensors and CMF400 sensors with booster amplifiers have different terminal pairs. If a short between terminals is indicated, contact customer service.

⁽¹⁾ LLC for all sensors except T-Series and CMF400 I.S. For T-Series sensors, functions as composite RTD. For CMF400 I. sensors, functions as fixed resistor.

Figure 9-3: Sensor pins -- Enhanced core processor

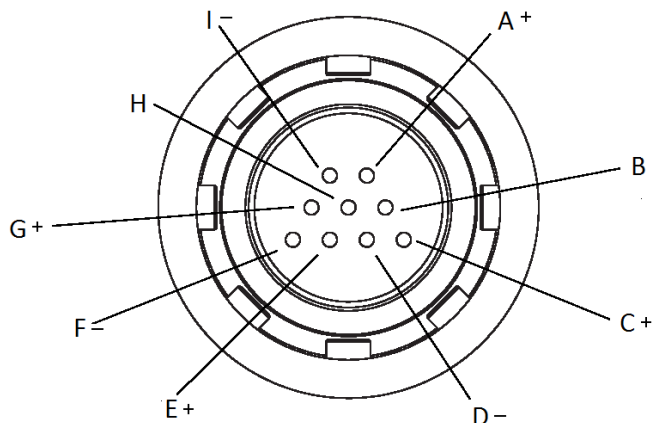

- A. Drive (positive)
- B. LLC / composite RTD / Fixed resistor⁽²⁾
- C. Right pickoff (positive)
- D. Right pickoff (negative)
- E. Left pickoff (positive)
- F. Left pickoff (negative)
- G. Resistance temperature detector (positive)
- H. Resistance temperature detector return / Lead length compensator (common) / composite RTD / fixed resistor
- I. Drive (negative)

Note

The pins are shown as they appear while looking at the feedthrough on the sensor.

Reinstalling the core processor

About this task

If you removed the core processor, replace the core processor using the instructions below.

Procedure

1. Determine whether you have a standard core processor or an enhanced core processor:
 - If you have a standard core processor, go to [Step 2](#).
 - If you have an enhanced core processor, go to [Step 4](#).
2. Align the three guide pins on the bottom of the core processor with the corresponding holes in the base of the core processor housing.

⁽²⁾ LLC for all sensors except T-Series and CMF400 I.S, and F300. For T-Series sensors, functions as composite RTD. For CMF400 I. S. and F300 sensors, functions as fixed resistor.

3. Carefully mount the core processor on the pins, taking care not to bend any pins, then go to [Step 6](#).
 4. Plug the sensor cable onto the feedthrough pins, being careful not to bend or damage any pins.
 5. Replace the core processor in the housing. then go to step 6.
-
6. **Note**
When reassembling the flowmeter components, grease all O-rings.
Tighten the captive screw(s) to 6 to 8 in-lbs (0,7 to 0,9 N-m) of torque.
 7. If you have a 4-wire remote installation, replace the core processor lid.
 8. If you have an integral installation:
 - a) Gently lower the transmitter onto the base, inserting the cap screws into the slots. Do not pinch or stress the wires.
 - b) Rotate the transmitter clockwise so that the cap screws are in the locked position.
 - c) Tighten the cap screws, torquing to 20 to 30 in-lbs (2,3 to 3,4 N-m).

A Flow meter installation types and components

This appendix provides illustrations of different flow meter installations and components for the Model 2700 transmitter.

Installation diagrams

Model 2700 transmitters can be installed in four different ways:

- Integral

Figure A-1: Integral installation

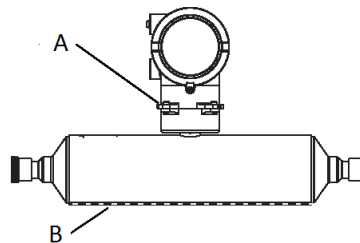

- A. Core processor (standard only)
- B. Sensor

- 4-wire remote

Figure A-2: 4-wire remote installation

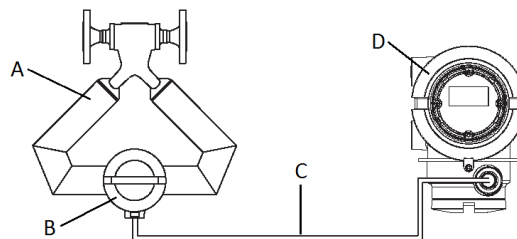

- A. Sensor
- B. Core processor (standard or enhanced)
- C. 4-wire cable
- D. Transmitter

- 9-wire remote

Figure A-3: 9-wire remote installation

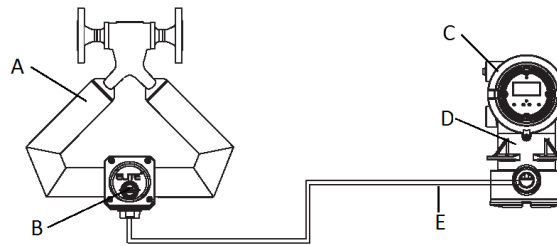

- A. Sensor
- B. Junction box
- C. Transmitter
- D. Core processor (standard only)
- E. 9-wire cable

- Remote core processor with remote transmitter

Figure A-4: Remote core processor with remote transmitter

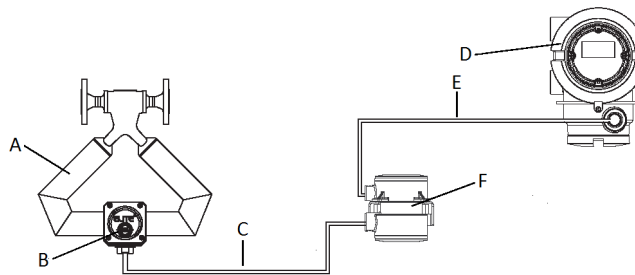

- A. Sensor
- B. Junction box
- C. 9-wire cable
- D. Transmitter
- E. 4-wire cable
- F. Core processor (standard or enhanced)

Component diagrams

The following figure shows the transmitter and core processor components in integral installations.

Figure A-5: Transmitter and core processor components -- integral installations

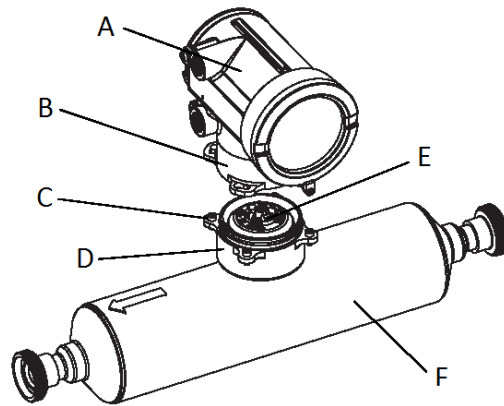

- A. Transmitter
- B. Transition ring
- C. 4 x cap screws (4mm)
- D. Base
- E. Core processor
- F. Sensor

The following figure shows the transmitter components in 4-wire remote installations and remote core processor with remote transmitter installations.

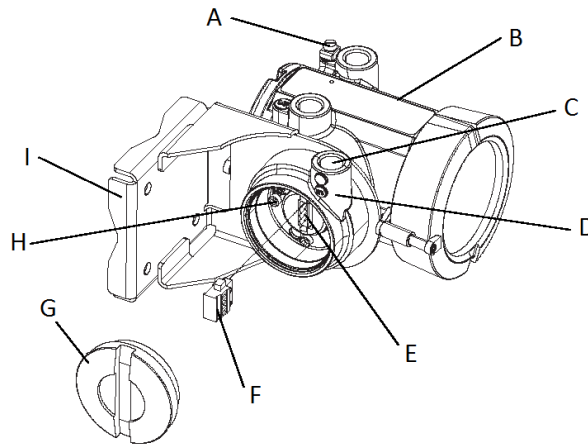
Figure A-6: Transmitter and core processor components -- 4-wire installations

- A. Ground lug
 - B. Main enclosure
 - C. Conduit operating for 4-wire cable
 - D. Junction housing
 - E. Mating connector socket
 - F. Mating connector
 - G. Junction end cap
 - H. 4 x cap screws (4mm)
 - I. Mounting bracket
-

The following figure shows the transmitter/core processor assembly in 9-wire remote installations. In remote core processor with remote transmitter installations, the core processor is installed stand-alone.

Figure A-7: Transmitter and core processor components -- 9-wire installations

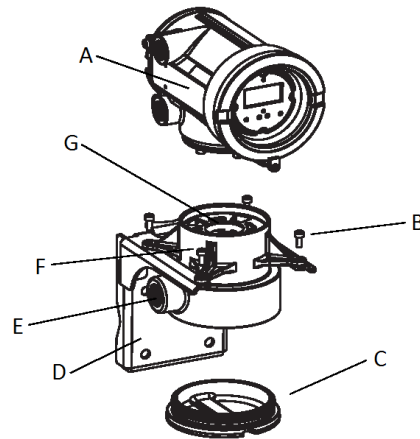

- A. Transmitter
- B. 4 x cap screws (4mm)
- C. End cap
- D. Mounting bracket
- E. Conduit opening for 9-wire cable
- F. Core processor housing
- G. Core processor

The following figure shows the remote core processor components for a remote installation.

Figure A-8: Transmitter and standard core processor components -- remote installations

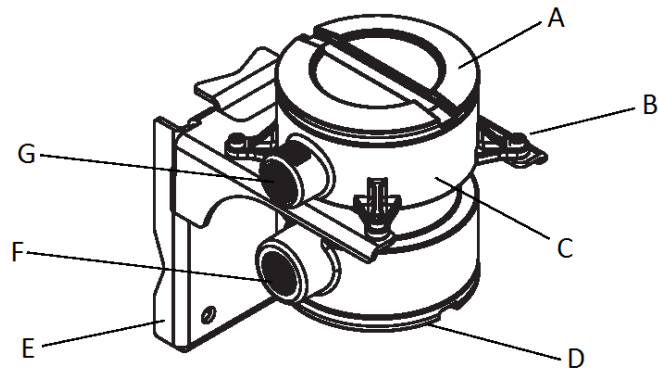

- A. Core processor lid
- B. 4 x cap screws (4mm)
- C. Core processor housing
- D. End cap
- E. Mounting bracket
- F. Conduit opening for 9-wire cable
- G. Conduit opening for 4-wire cable

Wiring and terminal diagrams

In 4-wire remote and remote core processor with remote transmitter installations, a 4-wire cable is used to connect the core processor to the transmitter's mating connector.

Figure A-9: 4-wire cable between Model 2700 Transmitter and standard core processor

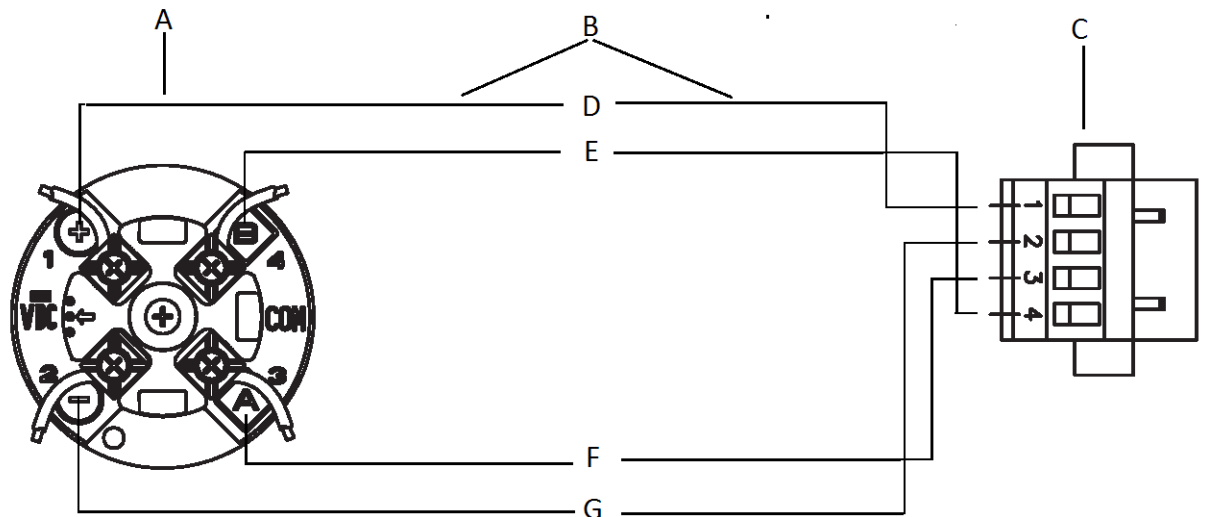

- A. Core processor terminals
- B. User-supplied or factory-supplied 4-wire cable
- C. Mating connector (transmitter)
- D. VDC+ (red)
- E. RS-485/B (green)
- F. RS-485/A (white)
- G. VDC- (black)

In 9-wire remote installations, a 9-wire cable is used to connect the junction box on the sensor to the terminals on the transmitter/core processor assembly.

Figure A-10: 4-wire cable between Model 2700 Transmitter and enhanced core processor

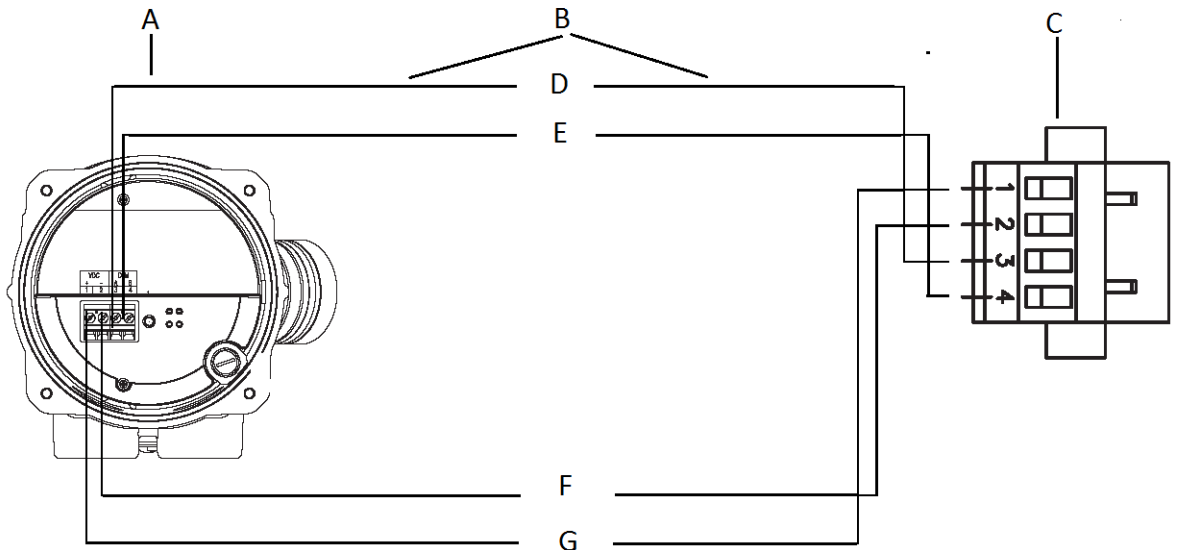

- A. Core processor terminals
- B. User-supplied or factory-supplied 4-wire cable
- C. Mating connector (transmitter)
- D. RS-485/A (white)
- E. RS-485/B (green)
- F. VDC- (black)
- G. VDC+ (red)

The following figures show the 9-wire connections for the sensor junction box and the core processor:

Figure A-11: 9-wire terminal connections to the sensor junction box for a Model 2700 Transmitter

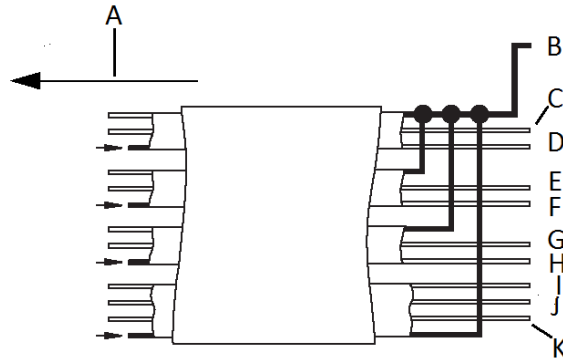

- A. To the junction box
- B. Black (drains from all wire sets)
- C. Green
- D. White
- E. Brown
- F. Red
- G. Blue
- H. Gray
- I. Orange
- J. Violet
- K. Yellow

Figure A-12: 9-wire terminal connections to the core processor for a Model 2700 Transmitter

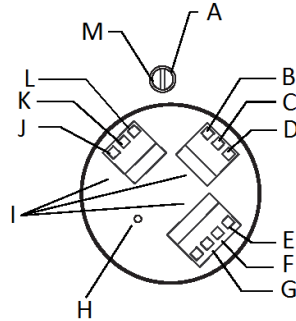

- A. Ground screw
- B. Red
- C. Green
- D. White
- E. Blue
- F. Gray
- G. Orange
- H. Mounting screw
- I. Plug and socket
- J. Yellow
- K. Violet
- L. Brown
- M. Black

The following figure shows the Model 2700 transmitter's power supply terminals.

Figure A-13: Output and power supply terminals for a Model 2700 Transmitter

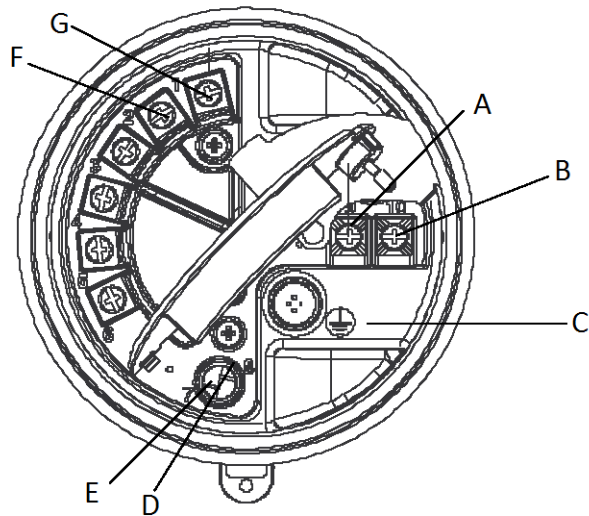

- A. 9 (-,N)
- B. 10 (+,L)
- C. Equipment ground
- D. Service port 8 (+)
- E. Service port 7 (-)
- F. PROFIBUS terminal 2
- G. PROFIBUS terminal 1

B Using the transmitter display

This section explains how to use the Model 5700 display. Using the display, you can move through the menus, configure the application, monitor and control the application, and perform maintenance and diagnostic tasks.

B.1 Components of the transmitter interface

The transmitter interface includes the status LED, the display (LCD panel), and two optical switches.

B.2 Use the optical switches

Use the optical switches on the transmitter interface to control the transmitter display. The transmitter has two optical switches: **Scroll** and **Select**.

About this task

Procedure

To activate an optical switch, block the light by holding your thumb or finger in front of the opening.

Tip

You can activate the optical switch through the lens. Do not remove the transmitter housing cover.

The optical switch indicator lights up when the transmitter senses that an optical switch has been activated.

Results

Table B-1: Optical switch indicator and optical switch states

Optical switch indicator	State of optical switches
Solid red	One optical switch is activated.
Flickering red	Both optical switches are activated.

B.3 Access and use the display menu system

The display menu system is used to perform various configuration, administrative, and maintenance tasks.

Prerequisites

To access the display menu system, operator access to either the **Off-Line** menu or the **Alert** menu must be enabled. To access the complete menu system, operator access must be enabled for both the **Off-Line** menu and the **Alert** menu.

About this task

Tip

The display menu system does not provide complete configuration, administrative, or maintenance functions. For complete transmitter management, you must use another communications tool.

Procedure

1. At the transmitter display, activate the **Scroll** and **Select** optical switches simultaneously until the display changes.
You will enter the **Off-Line** menu at any of several locations, depending on several factors.
 - If an alert is active and access to the **Alert** menu is enabled, you will see **SEE ALERT**.
 2. If **CODE?** appears on the display when you make a choice, enter the value that is configured for **Off-Line Password**.
 - a) With the cursor flashing on the first digit, activate **Scroll** until the correct digit is displayed, then activate **Select**.
 - b) Repeat this process for the second, third, and fourth digits.
-

Tip

If you do not know the correct value for **Off-Line Password**, wait 30 seconds. The password screen will time out automatically and you will be returned to the previous screen.

3. Use the **Scroll** and **Select** optical switches to navigate to your destination in the display menu system.
 - Use **Scroll** to move through a list of options.
 - Use **Select** to choose the current option.
4. If **Scroll** flashes on the display, activate the **Scroll** optical switch, then the **Select** optical switch, and then the **Scroll** optical switch again.
The display will prompt you through this sequence. The **Scroll-Select-Scroll** sequence is designed to guard against accidental activation of the off-line menu. It is not designed as a security measure.
5. To exit a display menu and return to a higher-level menu:
 - Activate **Scroll** until the **EXIT** option is displayed, then activate **Select**.
 - If the **EXIT** option is not available, activate **Scroll** and **Select** simultaneously and hold until the screen returns to the previous display.
6. To exit the display menu system, you can use either of the following methods:
 - Exit each menu separately, working your way back to the top of the menu system.
 - Wait two minutes until the display times out and returns to displaying process variable data.

B.3.1 Enter a floating-point value using the display

Certain configuration values (for example, **Lower Range Value** and **Upper Range Value**) are entered as floating-point values. The display supports both decimal notation and exponential notation for floating-point values.

About this task

The display allows you to enter a maximum of 8 characters, including the sign. The decimal point is not counted as a character. Exponential notation is used to enter values that require more than 8 characters.

B.3.1 Enter a floating-point value using decimal notation

Decimal notation allows you to enter values between –9999999 and 99999999. You can use the decimal point to enter values with a precision of 0 through 4 (4 characters to the right of the decimal point).

About this task

Decimal values entered via the display must meet the following requirements:

- They can contain a maximum of 8 digits, or 7 digits plus a minus sign (–) to indicate a negative number.
- They can contain a decimal point. The decimal point does not count as a digit. The decimal point must be positioned so that the precision of the value does not exceed 4.

When you first enter the configuration screen, the current configuration value is displayed in decimal notation, and the active character is flashing. If the value is positive, no sign is displayed. If the value is negative, a minus sign is displayed.

Procedure

- To change the value:
 - a) Activate **Select** until the digit you want to change is active (flashing).
Select moves the cursor one position to the left. From the leftmost position, **Select** moves the cursor to the rightmost digit.
 - b) Activate **Scroll** to change the value of the active digit.
 - c) Repeat until all digits are set as desired.
- To change the sign of the value:
 - If the current value is negative, activate **Select** until the minus sign is flashing, then activate **Scroll** until the space is blank.
 - If the current value is positive and there is a blank space at the left of the value, activate **Select** until the cursor is flashing under the blank space, then activate **Scroll** until the minus sign appears.
 - If the current value is positive and there is no blank space at the left of the value, activate **Select** until the cursor is flashing under the leftmost digit, then activate **Scroll** until the minus sign appears.
- To move the decimal point:
 - a) Activate **Select** until the decimal point is flashing.
 - b) Activate **Scroll**.
The decimal point is removed from its current position.

- c) Activate **Select** and watch the position of the decimal point.
As the cursor moves to the left, the decimal point will flash between each pair of digits, up to a maximum precision of four (four digits to the right of the decimal point).

Tip

If the position is not valid, the decimal point is not displayed. Continue to activate **Select** until the decimal point appears at the right of the displayed value.

- d) When the decimal point is in the desired position, activate **Scroll**.
The decimal point is inserted at its current position.
- To save the displayed value to transmitter memory, activate **Scroll** and **Select** simultaneously and hold until the display changes.
 - If the displayed value is the same as the value in transmitter memory, you will be returned to the previous screen.
 - If the displayed value is not the same as the value in transmitter memory, **SAVE/YES?** flashes on the display. Activate **Select**.
 - To exit the menu without saving the displayed value to transmitter memory, activate **Scroll** and **Select** simultaneously and hold until the display changes.
 - If the displayed value is the same as the value in transmitter memory, you will be returned to the previous screen.
 - If the displayed value is not the same as the value in transmitter memory, **SAVE/YES?** flashes on the display. Activate **Scroll**.

B.3.1 Enter a floating-point value using exponential notation

Exponential notation is used to enter values that are larger than 99999999 or smaller than -99999999.

About this task

Exponential values entered via the display must be in the following form: $SX.XXXEYY$. In this string:

- S = Sign. A minus sign (-) indicates a negative number. A blank indicates a positive number.
- X.XXX = The 4-digit mantissa.
- E = The exponent indicator.
- YY = The 2-digit exponent.

Procedure

1. Switch from decimal notation to exponential notation.
 - a) Activate **Select** as required until the rightmost digit is flashing.
 - b) Activate **Scroll** until E is displayed.
 - c) Activate **Select**.

Tip

If you have modified the value in decimal notation without saving the changes to transmitter memory, the changes will be lost when you switch to exponential notation. Save the decimal value before switching to exponential notation.

2. Enter the exponent.

The first character may be a minus sign or any digit between 0 and 3. The second character may be any digit between 0 and 9.

- a) Activate **Select** to move the cursor to the rightmost character on the display.
- b) Activate **Scroll** until the desired character is displayed.
- c) Activate **Select** to move the cursor one position to the left.
- d) Activate **Scroll** until the desired character is displayed.

3. Enter the mantissa.

The mantissa must be a 4-digit value with a precision of 3 (that is, all values between 0.000 and 9.999).

- a) Activate **Select** to move the cursor to the rightmost digit in the mantissa.
- b) Activate **Scroll** until the desired character is displayed.
- c) Activate **Select** to move the cursor one digit to the left.
- d) Activate **Scroll** until the desired character is displayed.
- e) Activate **Select** to move the cursor one digit to the left.
- f) Activate **Scroll** until the desired character is displayed.
- g) Activate **Select** to move the cursor one digit to the left.
- h) Activate **Scroll** until the desired character is displayed.

4. Enter the sign.

- a) Activate **Select** to move the cursor one digit to the left.
- b) Activate **Scroll** until the desired character is displayed.

For positive numbers, select a blank space.

5. To save the displayed value to transmitter memory, activate **Scroll** and **Select** simultaneously and hold until the display changes.

- If the displayed value is the same as the value in transmitter memory, you will be returned to the previous screen.
- If the displayed value is not the same as the value in transmitter memory, **SAVE/YES?** flashes on the display. Activate **Select**.

6. Switch back from exponential notation to decimal notation.

- a) Activate **Select** until the **E** is flashing.
- b) Activate **Select** until **d** is displayed.
- c) Activate **Select**.

B.4 Display codes for process variables

Table B-2: Display codes for process variables

Code	Definition	Comment or reference
AVE_D	Average density	Petroleum measurement application only
AVE_T	Average temperature	Petroleum measurement application only
BRD_T	Board temperature	
CONC	Concentration	Concentration measurement application only
DRIVE%	Drive gain	
EXT_P	External pressure	
EXT_T	External temperature	
GSV F	Gas standard volume flow	
GSV I	Gas standard volume inventory	
GSV T	Gas standard volume total	
LPO_A	Left pickoff amplitude	
LVOLI	Volume inventory	
LZERO	Live zero flow	
MASSI	Mass inventory	
MTR_T	Case temperature (T-Series sensors only)	
NET M	Net mass flow rate	Concentration measurement application only
NET V	Net volume flow rate	Concentration measurement application only
NETMI	Net mass inventory	Concentration measurement application only
NETVI	Net volume inventory	Concentration measurement application only
PWRIN	Input voltage	Refers to power input to the core processor
RDENS	Density at reference temperature	Concentration measurement application only
RPO_A	Right pickoff amplitude	
SGU	Specific gravity units	
STD V	Standard volume flow rate	Concentration measurement application only
STDVI	Standard volume inventory	Concentration measurement application only
TCDENS	Temperature-corrected density	Petroleum measurement application only
TCORI	Temperature-corrected inventory	Petroleum measurement application only
TCORR	Temperature-corrected total	Petroleum measurement application only
TCVOL	Temperature-corrected volume	Petroleum measurement application only
TUBEF	Raw tube frequency	
WTAVE	Weighted average	

B.5 Codes and abbreviations used in display menus

Table B-3: Codes and abbreviations used in display menus

Code or abbreviation	Definition	Comment or reference
ACK ALERT	Acknowledge alert	
ACK ALL	Acknowledge all alerts	
ACT	Action	
ADDR	Address	
AO1	Analog output 1 (primary mA Output)	
AO 1 SRC	Fixed to the process variable assigned to the primary output	
AO2	Analog output 2 (secondary mA Output)	
AUTO SCROLL	Auto Scroll	
BKLT B LIGHT	Backlight	
CAL	Calibrate	
CH A	Channel A	
CHANGE PASSW CHANGE CODE	Change password or passcode	Change the password or passcode required for access to display functions
CH B	Channel B	
CH C	Channel C	
CONFIG	Configuration	
CORE	Core processor	
CUR Z	Current zero	
CUSTODY XFER	Custody transfer	
DENS	Density	
DEV	Discrete event	Events configured using the enhanced event model
DGAIN, DRIVE %	Drive gain	
DISBL	Disable	Select to disable

Table B-3: Codes and abbreviations used in display menus (continued)

Code or abbreviation	Definition	Comment or reference
DO1	Discrete Output 1	
DO2	Discrete Output 2	
DSPLY	Display	
E1OR2	Event 1 or Event 2	Events configured using the basic event model
ENABL	Enable	Select to enable
ENABLE ACK	Enable acknowledge all	Enable or disable the ACK ALL function
ENABLE ALERTS	Enable alert menu	Access to alert menu from display
ENABLE AUTO	Enable Auto Scroll	Enable or disable the Auto Scroll function
ENABLE OFFLN	Enable off-line	Access to off-line menu from display
ENABLE PASSW	Enable password	Enable or disable password protection for display functions
ENABLE RESET	Enable totalizer reset	Enable or disable totalizer reset from display
ENABLE START	Enable totalizer start	Enable or disable totalizer start/stop from display
EVNT1	Event 1	Event configured using the basic event model only
EVNT2	Event 2	Event configured using the basic event model only
EXTRN	External	
FAC Z	Factory zero	
FCF	Flow calibration factor	
FLDIR	Flow direction	
FL SW FLSWT	Flow switch	
FO	Frequency Output	
FO FREQ	Frequency factor	
FO RATE	Rate factor	
FREQ	Frequency	
FR FL	Frequency=Flow	
GSV	Gas standard volume	
HYSTRSIS	Hysteresis	
INTERN	Internal	
IO	Input/output	
LANG	Language	
LOCK	Write-protect	

Table B-3: Codes and abbreviations used in display menus (continued)

Code or abbreviation	Definition	Comment or reference
LOOP CUR	Loop current	
M_ASC	Modbus ASCII	
M_RTU	Modbus RTU	
MAO1	mA Output 1 (primary mA Output)	
MAO2	mA Output 2 (secondary mA Output)	
MASS	Mass flow	
MBUS	Modbus	
MFLOW	Mass flow	
MSMT	Measurement	
MTR F	Meter factor	
OFF-LINE MAINT	Off-line maintenance	
OFFLN	Off-line	
P/UNT	Pulses/unit	
POLAR	Polarity	
PRESS	Pressure	
QUAD	Quadrature	
r.	Revision	
SCALE	Scaling method	
SIM	Simulation	Used for loop testing, not simulation mode. Simulation mode is not accessible through the display.
SPECL	Special	
SRC	Source	Variable assignment
TEMP, TEMPR	Temperature	
UNT/P	Units/pulse	
VAR 1	Display Variable 1	
VER	Version	
VERFY	Verify	
VFLOW	Volume flow	
VOL	Volume, volume flow	

Table B-3: Codes and abbreviations used in display menus (continued)

Code or abbreviation	Definition	Comment or reference
WRPRO	Write protect	PVR applications only
XMTR	Transmitter	

B.6 Display menus

These figures show the commands accessible through the display for specific configuration and maintenance tasks.

Main Display menu

Figure B-1: Display menu -- Main

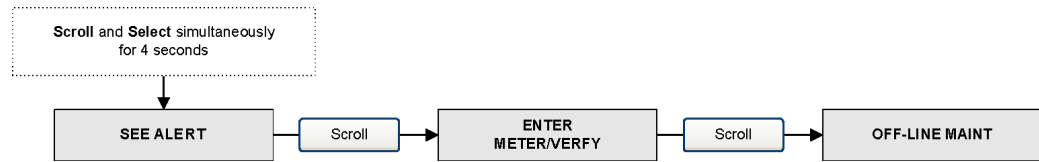

Alerts (alarms) from the Display menu

Figure B-2: Display menu -- Alerts

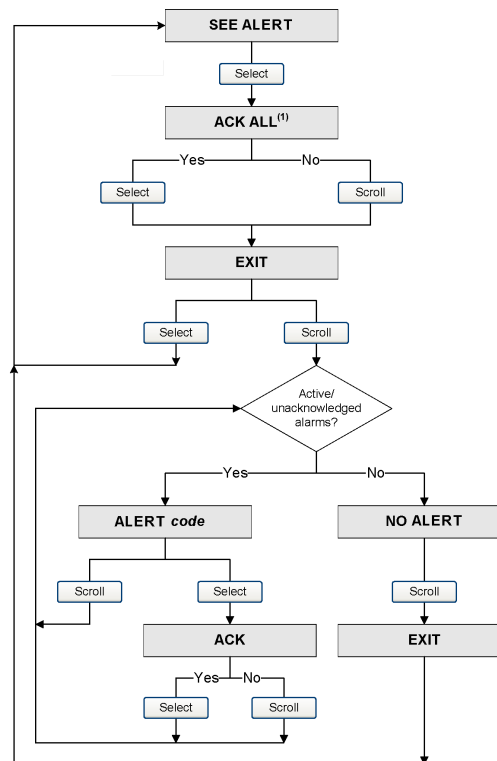

Off-line maintenance from the Display menu

Figure B-3: Display menu -- Off-line maintenance: configuration

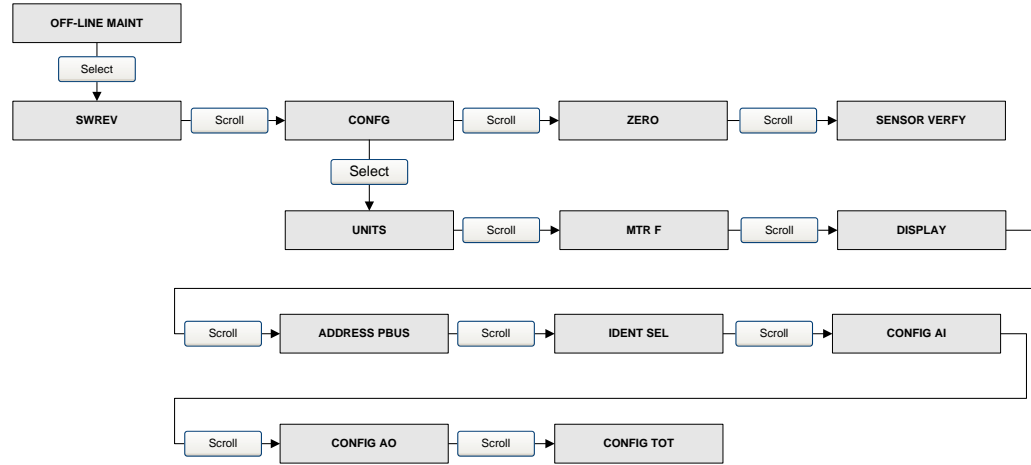
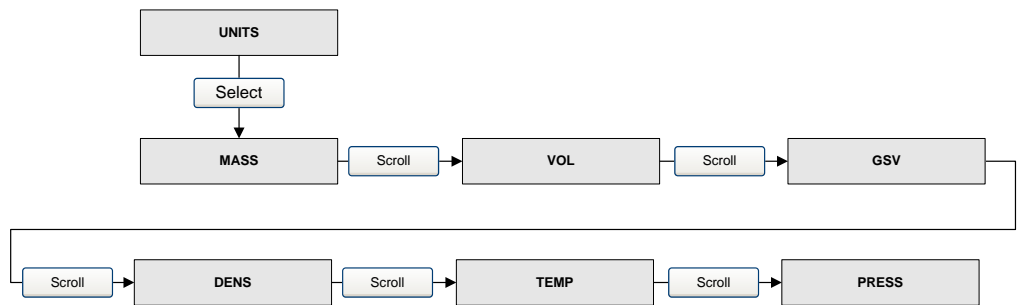

Figure B-4: Display menu -- Off-line maintenance: configuration -- units



These are the Transducer block engineering units.

Important

The Transducer block engineering units must match the AI function block engineering units (Figure B-7) or it results in a configuration error.

Figure B-5: Display menu -- Off-line maintenance: configuration -- meter factors



Figure B-6: Display menu -- Off-line maintenance: configuration -- Display

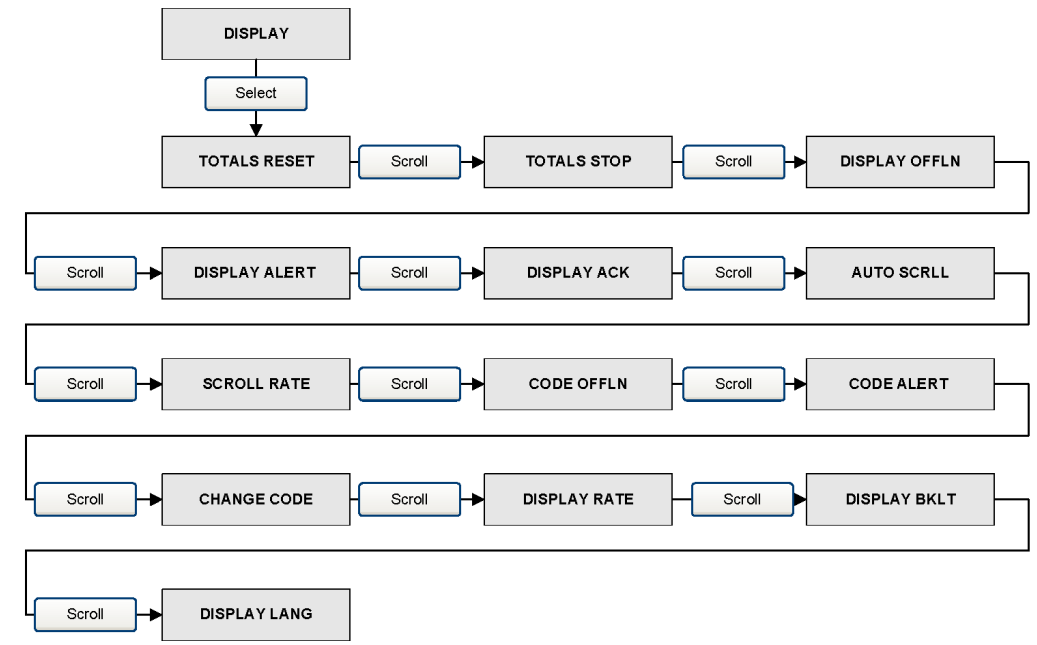
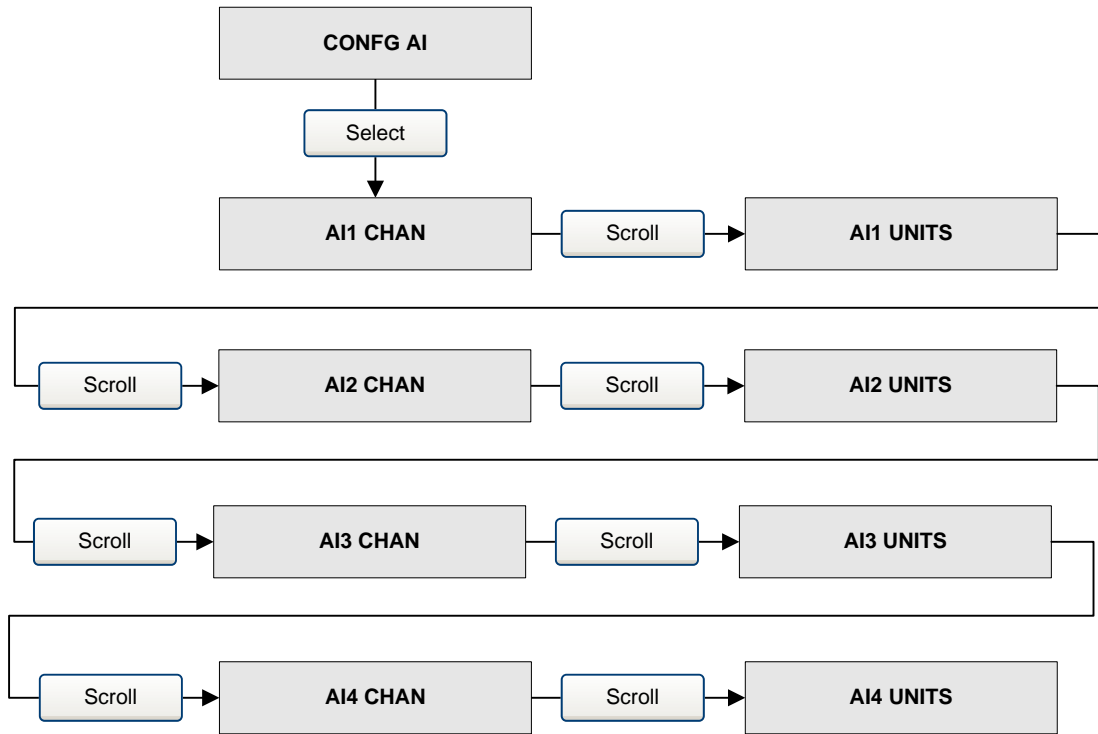

Figure B-7: Display menu -- Off-line maintenance: configuration -- Analog Input blocks



These are the Analog Input block engineering units.

Important

The Analog Input function block engineering units must match the Transducer block engineering units (Figure B-4) or it results in a configuration error.

Figure B-8: Display menu -- Off-line maintenance: configuration -- Analog Output blocks

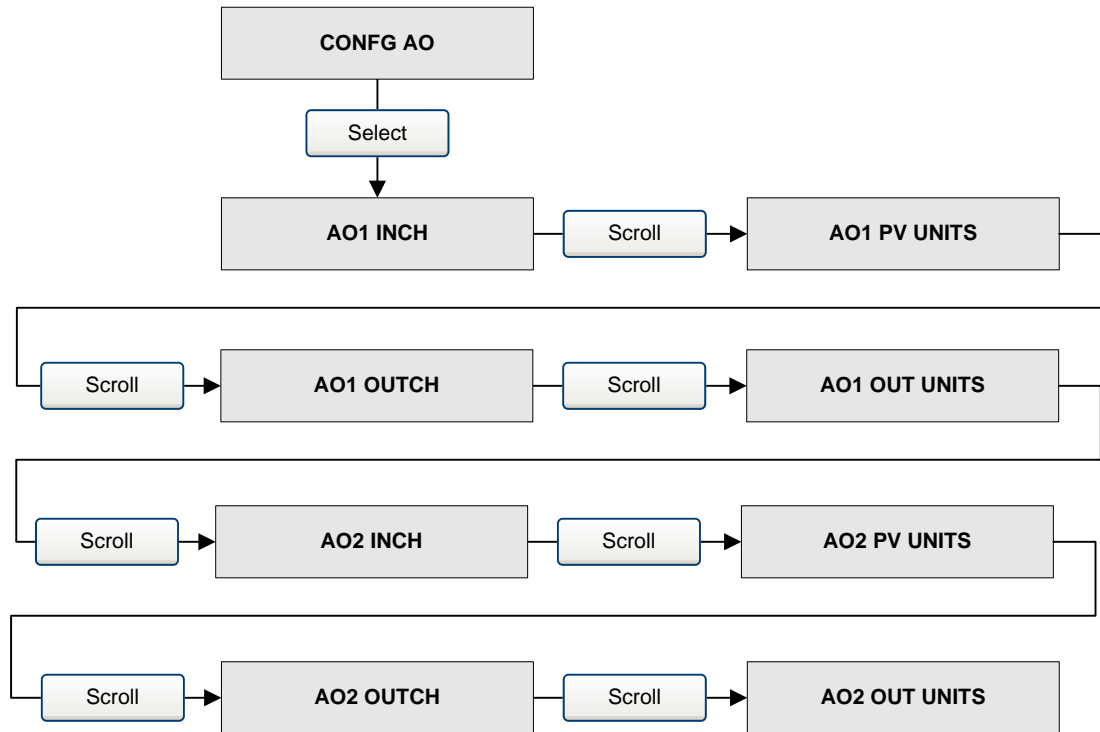

These are the Analog Output block engineering units.

Important

The Analog Output block engineering units must match the Transducer block engineering units (Figure B-4) or it results in a configuration error.

Figure B-9: Display menu -- Off-line maintenance: configuration -- Totalizers

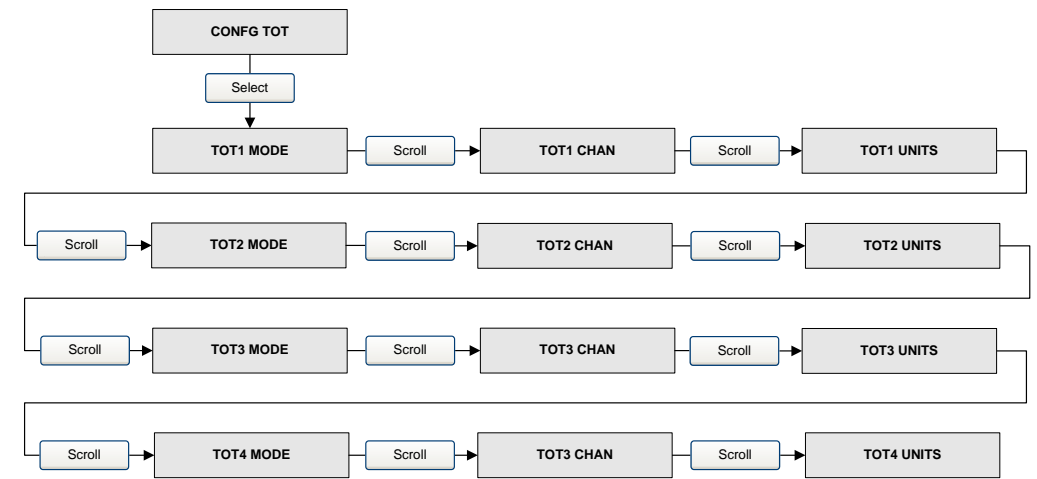

Figure B-10: Display menu -- Off-line maintenance: Zeroing

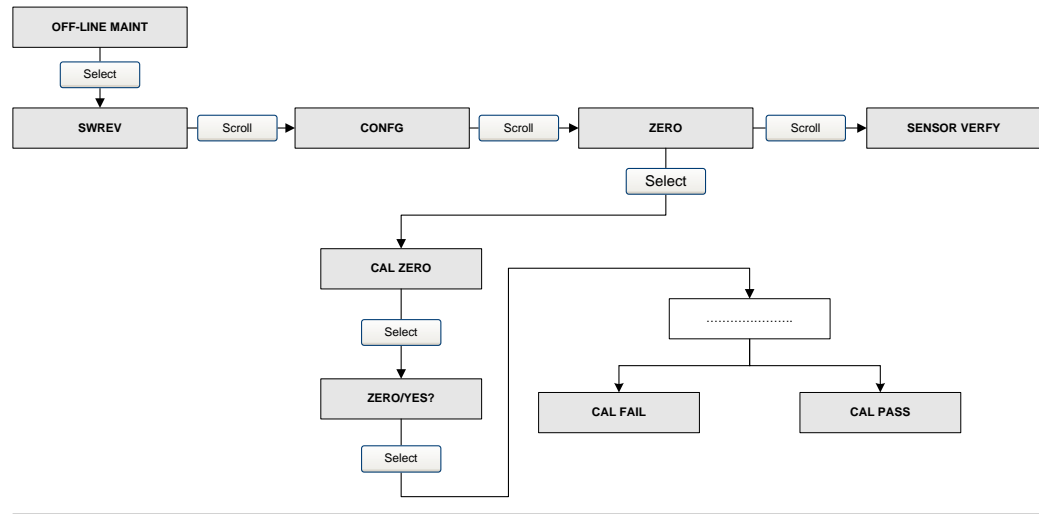
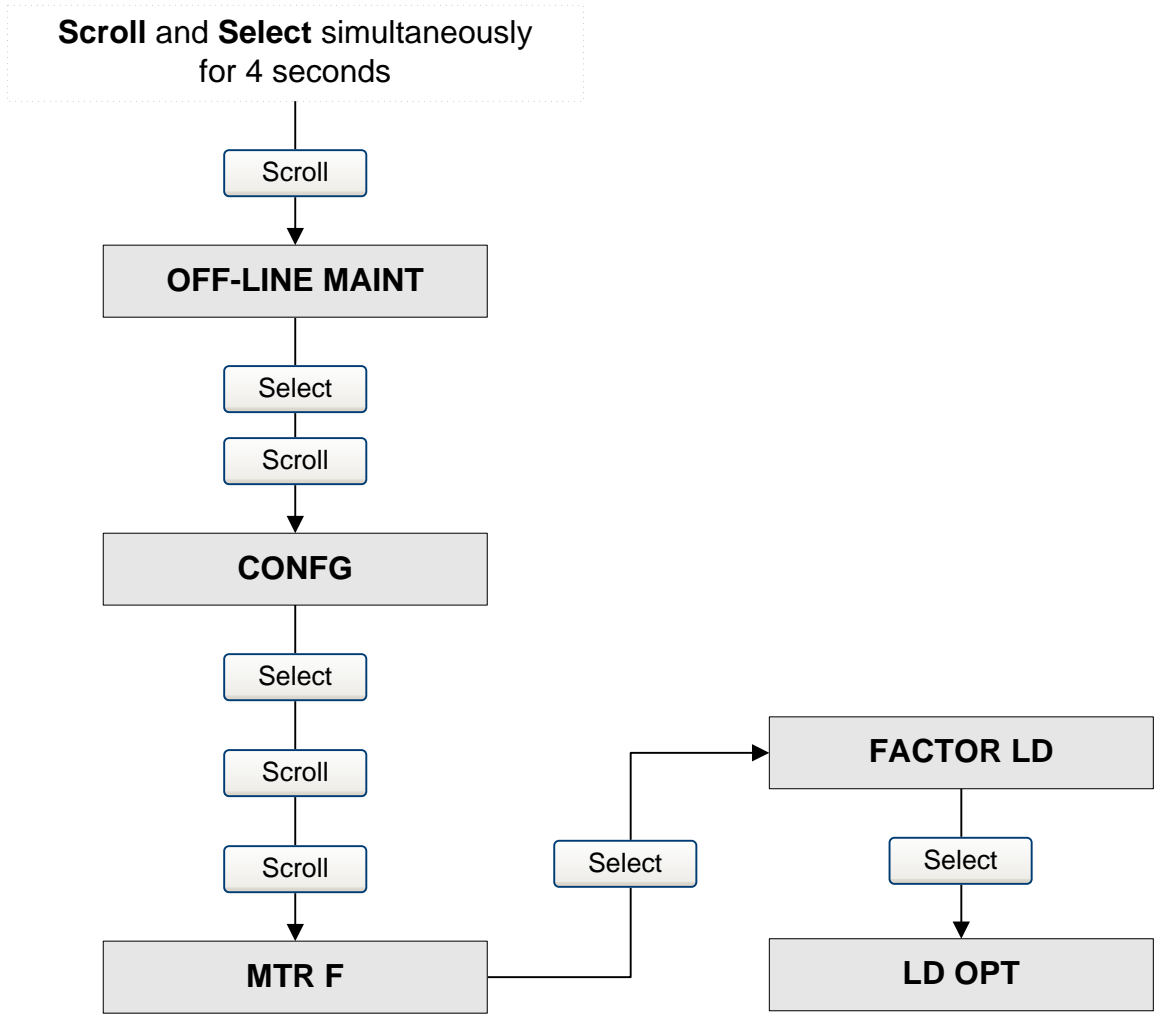

Figure B-11: Display menu -- Off-line maintenance: LD optimization



C Using ProLink III with the transmitter

C.1 Basic information about ProLink III

ProLink III is a configuration and service tool available from Micro Motion. ProLink III runs on a Windows platform and provides complete access to transmitter functions and data.

Version requirements

To support all the latest firmware features, device firmware v8.0, ProLink III v4.0 or later is required. For details about ProLink III device support, refer to the `ProLink III ChangeLog.txt` file.

ProLink III requirements

To install ProLink III, you must have:

- The ProLink III installation media
- The ProLink III installation kit for your connection type:

To obtain ProLink III and the appropriate installation kit, contact customer support.

ProLink III documentation

Most of the instructions in this manual assume that you are already familiar with ProLink III or that you have a general familiarity with Windows programs. If you need more information than this manual provides, see the *ProLink® III Configuration and Service Tool for Micro Motion® Transmitters: User Manual*.

In most ProLink III installations, the manual is installed with the ProLink III program. Additionally, the ProLink III manual is available on the documentation CD or at .

ProLink III features and functions

ProLink III offers complete transmitter configuration and operation functions. ProLink III also offers a number of additional features and functions, including:

- A Professional version with expanded features not available on the Basic version.
- The ability to save the transmitter configuration set to a file on the PC, and reload it or propagate it to other transmitters
- The ability to log specific types of data to a file on the PC
- The ability to view performance trends for various types of data on the PC
- The ability to connect to and view information for more than one device
- A guided connection wizard

These features are documented in the ProLink III manual. They are not documented in the current manual.

ProLink III messages

As you use ProLink III with a Micro Motion transmitter, you will see a number of messages and notes. This manual does not document all of these messages and notes.

Important

The user is responsible for responding to messages and notes and complying with all safety messages.

C.2 Connect with ProLink III

A connection from ProLink III to your transmitter allows you to read process data, configure the transmitter, and perform maintenance and troubleshooting tasks.

C.2.1 Connection types supported by ProLink III

Different connection types are available for connecting from ProLink III to the transmitter. Choose the connection type appropriate to your network and the tasks you intend to perform.

The transmitter supports the following ProLink III connection types:

- Service port connections

C.2.2 Connect with ProLink III to the service port

Prerequisites

- ProLink III is installed and licensed on your PC
- One of the following:
 - RS-232 to RS-485 signal converter
 - USB to RS-485 signal converter
- An available serial port or USB port
- Adapters as required (for example, 9-pin to 25-pin)

About this task**Procedure**

1. Attach the signal converter to the serial port or USB port on your PC.
2. Access the service port terminals:
 - a) Remove the transmitter end-cap to access the wiring compartment.
 - b) Loosen the screw on the Warning flap and open the power supply compartment.
3. Start ProLink III.
4. Choose **Connect to Physical Device**.
5. Set **Protocol** to Service Port.

Tip

Service port connections use standard connection parameters and a standard address. You do not need to configure them here.

6. Set the **PC Port** value to the PC COM port that you are using for this connection.
7. Click **Connect**.

Need help?

If an error message appears:

- Switch the leads and try again.
 - Ensure that you have specified the correct port on your PC.
 - Check the wiring between the PC and the transmitter.
-

D PROFIBUS-PA status byte

This appendix describes the status byte reported by the transmitter to a PROFIBUS host. The output of each AI, AO, and totalizer function block is a 5-byte package: four bytes of process information and one byte indicating measurement quality, also called the status byte. The format of the status byte depends on whether the transmitter is configured for classic mode or condensed mode.

Classic-mode status byte format

The following six tables describe the format of the status byte when the transmitter is configured for classic mode. Refer to Section 3.7.3.6 of the PROFIBUS-PA Profile for Process Control Devices v3.01 for more information.

Table D-1: Classic-mode status byte format

Status bits	Meaning	Comment
00	Bad	The measurement is not useful.
01	Uncertain	The quality of the measurement is below normal, but may still be useful.
10	Good - Non-cascade	The quality of the measurement is good, but alerts may be indicated by the sub-status.
11	Good - Cascade	The measurement is good.

Table D-2: Sub-status format -- Bad status

Status bits	Meaning	Comment
0011	Device failure	TRUE if the following alert codes are active: A001, A002, A014, A029, or A030.
0100	Sensor failure	TRUE if the following alert codes are active: A003, A004, A005, A016, or A017.
0111	OOS	See the profile specification for details.

Table D-3: Sub-status format -- Uncertain status

Status bits	Meaning	Comment
0000	Non-specific	TRUE if the following alert codes are active: A005, A008, A010, A011, A012, A013, A021, A033, or A102.
0011	Initial value	TRUE if the following alert codes are active: A006 or A120.
1000	Simulated value	TRUE if the following alert codes are active: A132.
1001	Sensor calibration	TRUE if the following alert codes are active: A104.

Table D-4: Sub-status format -- Good status (non-cascade)

Status bits	Meaning	Comment
0001	Update event	
0010	Active advisory alert	
0011	Active critical alert	

Table D-5: Sub-status format -- Good status (Cascade)

Status bits	Meaning	Comment
0000	OK	This bit is set if no alerts are active.

Table D-6: Limit bits

Bits	Meaning	Comment
00	OK	
01	Low limited	
10	High limited	
11	Constant	

Condensed-mode status byte format

The following table describes the format of the status byte when the transmitter is configured for condensed mode. Refer to the PROFIBUS Specification Profile for Process Control Devices Version v3.01 December 2004 and the PROFIBUS Specification June 2005 Amendment 2 to the PROFIBUS Profile for Process Control Devices v3.01, Condensed Status and Diagnostic Messages v1.0 for additional information.

Table D-7: Condensed-mode status byte format

Expanded status	Condensed status	Alerts
BAD_DEVICE_FAIL (0x0C)	C_BAD_MAINTENANCE_ALARM (0x24.....0x27) ⁽¹⁾⁽²⁾	A001, A002, A014, A029, A030 <ul style="list-style-type: none"> • A001-- EEPROM Checksum Error • A002-- RAM/ROM Test Error • A014-- Transmitter Failed • A029-- Internal communication failure (PIC/daughterboard) • A030-- Hardware/Software incompatible (board type missing)
BAD_SENSOR_FAIL (0x10)	C_BAD_PROCESS_RELATED (0x2B) ⁽²⁾	A003, A004, A016, A017 <ul style="list-style-type: none"> • A003-- Sensor Not Responding (No Tube Interrupt) • A004-- Temperature Sensor Out-of-Range • A016-- "Line RTD" Temperature-Out-of-Range • A017-- "Meter RTD" Temperature-Out-of-Range
BAD_CFG_ERROR (0x04)	C_BAD_FUNCTION_CHECK (0x3C0x3F) ⁽¹⁾⁽²⁾	<ul style="list-style-type: none"> • A006-- Transmitter Not Characterized • A020-- Calibration Factors Unentered • A021-- Unrecognized/Unentered Sensor
BAD_NON_SPECIFIC (0x00)	BAD_NON_SPECIFIC (0x00)	All the remaining fault alerts are under this category.

Table D-7: Condensed-mode status byte format (continued)

Expanded status	Condensed status	Alerts
UC_SIMULATED_VALUE (0x60)	C_UNCERTAIN_SIMULATED_VALUE_START (0x73)	<ul style="list-style-type: none"> A132-- Simulation Mode Active
UC_SENSOR_CAL (0x64)	C_BAD_FUNCTION_CHECK (0x3C0x3F) ^{(1) (2)}	<ul style="list-style-type: none"> A104-- Calibration-In-Progress
UC_CFG_ERROR (0x5C)	C_BAD_FUNCTION_CHECK (0x3C.....0x3F) ^{(1) (2)}	<ul style="list-style-type: none"> A006-- Transmitter Not Characterized A020-- Calibration Factors Unentered A021-- Unrecognized/Unentered Sensor
UC_NON_SPECIFIC (0x40)	C_UNCERTAIN_PROCESS_RELATED (0x78..0x7B) ⁽¹⁾	<ul style="list-style-type: none"> A005 -- Input Over Range A008-- Density Outside Limits A010-- Calibration Failure A011-- Excess Calibration Correction A012-- Excess Calibration Correction A013-- Process too Noisy to Perform Auto A033-- Tube Not Full A102-- Drive Over Range
GOOD_NC_ADV_ALARM (0x88)	C_GOOD_ACTIVE_ADVISORY_ALARM (0x88.....0x91) ⁽¹⁾	All informational alerts.
GOOD_NC_UPDATE_EVT (0x84)	C_GOOD_UPDATE_EVENT (0x84)	ST REV update for transducer blocks.
GOOD_CAS_OK (0xC0)	C_GOOD_CAS_OK (0xC0)	None of the alerts stated above are active.
BAD_OUT_OF_SERVICE LIMIT_CONSTANT (0x1C)	C_BAD_PASSIVATED (0x23)	When the Actual mode of AI, AO, or Totalizer blocks are Out of Service.
Totalizer Fail Safe: UC_NON_SPECIFIC (0x40)	C_UNCERTAINC_SUBSTITUTE_SET (0x4B)	Failsafe – RUN mode

Table D-7: Condensed-mode status byte format (continued)

Expanded status	Condensed status	Alerts
Totalizer Fail Safe: UC_LUV (0x44)	C_UNCERTAINC_PROCESS_RELATED (0x78....0x7B) ⁽¹⁾	Failsafe – HOLD_LUV mode
Totalizer Fail Safe: UC_NON_SPECIFIC (0x40)	C_UNCERTAINC_SUBSTITUTE_SET (0x4B)	Failsafe – MEMORY mode
UC_INITIAL_VAL (0x4C)	C_UNCERTAIN_INITIAL_VALUE (0x4F)	When reset or preset totals.
UC_SUBSTITUTE_VAL (0x48)	C_UNCERTAIN_SUBSTITUTE_SET (0x4B)	AO failsafe active.

(1) Limits status as applicable.

(2) AI function block FB behaves like FSAFE_TYPE = 1 as per Section 3.3.1 (Table 19) of the PROFIBUS Specification June2005, Order no. 3.042, Amendment2 to the PROFIBUS Profile for Process Control Devices v3.01, Condensed Status and Diagnostic Messages v1.0.

E Slave diagnostic response bytes

This appendix describes the diagnostic bytes reported by the transmitter to a PROFIBUS host.

Overview

There are two sets of diagnostic bytes sent:

- Bytes 1–6 conform to the standard PROFIBUS specification.
- Byte 7 is the extended diagnostic header byte.
- Bytes 8–15 are extended diagnostic bytes that conform to the Profile 3.01 specification and the Diagnosis, Alerts, and Time-stamping Profile Guidelines.
- The final 10 bytes are extended diagnostic bytes that correspond to alerts in the transmitter. Alert codes referenced in these bytes are the codes shown on the transmitter display. Refer to [Status alerts](#) for more information about alert codes.

Note

AI, AO, and totalizer function blocks will go into OOS mode when any of the following diagnostics bits are set: 24 (hardware failure), 28 (memory error), or 29 (measurement failure). There can be as many as 62 device-related diagnostic bytes.

PROFIBUS specification diagnostic bytes

The following 22 tables describe the PROFIBUS diagnostic response bytes.

Table E-1: Byte 1

Bit	Indication
0	Station not existent (this is set by the master if the slave does not respond)
1	Station not ready for data exchange
2	Configuration fault: slave did not accept last configuration data
3	Slave has extended diagnostic data to report
4	Slave does not support requested parameter function
5	Invalid slave response (this is set by the master)
6	Parameter fault: slave did not accept last parameterization data
7	Slave is locked or controlled by another master (this is set by the master)

Table E-2: Byte 2

Bit	Indication
0	Slave must be parameterized
1	Static diagnostic: master requesting diagnostics until bit is reset
2	This bit is always set to 1

Table E-2: Byte 2 (continued)

Bit	Indication
3	Response monitoring/watchdog (1 = ON; 0 = OFF)
4	Slave is in freeze mode (1 = ON; 0 = OFF)
5	Slave is in sync mode (1 = ON; 0 = OFF)
6	Reserved
7	Slave is deactivated in master parameter set (this is set by the master)

Table E-3: Byte 3

Bit	Indication
0	Reserved (always set to 0)
1	Reserved (always set to 0)
2	Reserved (always set to 0)
3	Reserved (always set to 0)
4	Reserved (always set to 0)
5	Reserved (always set to 0)
6	Reserved (always set to 0)
7	Diagnostic overflow—transmitter has more diagnostic data than it can report

Table E-4: Byte 4

Bit	Indication
0	Master station address
1	An address in the range of 0–125 decimal (0x0–0x7D hex) is the address of the controlling master. An address of 255 decimal (0xFF hex) means the slave is not controlled or parameterized by a master.
2	
3	
4	
5	
6	
7	

Table E-5: Byte 5

Bit	Indication
0	Ident number (MSB) ⁽¹⁾

Table E-5: Byte 5 (continued)

Bit	Indication
1	
2	
3	
4	
5	
6	
7	

(1) The identification number will be 0x9742 when in profile-specific I/O mode and 0x057A when in manufacturing-specific I/O mode. Refer to Section 2.5 for information about I/O modes.

Table E-6: Byte 6

Bit	Indication
0	Ident number (LSB)
1	
2	
3	
4	
5	
6	
7	

Table E-7: Byte 7 -- Extended diagnostic header byte

Bit	Indication
0	Number of extended diagnostic bytes (including this header byte)
1	
2	
3	
4	
5	
6	Identifier for device-related diagnostics status model (0x00)
7	

Table E-8: Byte 8 -- Status Type = 0xFE

Bit	Indication
8	Status type = manufacturer-specific (32 decimal, 0x20 hex)
9	
10	
11	
12	
13	
14	
15	

Table E-9: Byte 9 -- Slot Number = 0x00

Bit	Indication
8	Slot number of physical block (per Profile 3.01 this is 0)
9	
10	
11	
12	
13	
14	
15	

Table E-10: Byte 10 -- Status Specifier

Bit	Indication
16	Error appears (when any new alert is activated)
17	Error disappears (when an alert is deactivated)
18	Reserved
19	Reserved
20	Reserved
21	Reserved
22	Reserved
23	Reserved

Table E-11: Byte 11 -- User Diagnostics

Bit	Indication
24	Reserved (always set to 0)
25	Reserved (always set to 0)
26	Reserved (always set to 0) -- Not used
27	Reserved (always set to 0)
28	Reserved (always set to 0)
29	Reserved (always set to 0)
30	Reserved (always set to 0)
31	Reserved (always set to 0)

Table E-12: Byte 12 -- User Diagnostics

Bit	Indication
32	Reserved
33	Reserved
34	Reserved
35	Restart (A107)
36	Cold start (A107)
37	Maintenance required--Not used
38	Reserved
39	Ident_Number violation

Table E-13: Byte 13 -- User Diagnostics = 0X00

Bit	Indication
40	Maintenance alert (A014, A001, A002, A003, A022, A023, A024, A026)
41	Maintenance demanded (A103)
42	Function check (A106 if any function block is in simulation mode)
43	PRO_COND (not used)
44	Reserved (always set to 0)
45	Reserved (always set to 0)
46	Reserved (always set to 0)
47	Reserved (always set to 0)

Table E-14: Byte 14 -- User Diagnostics

Bit	Indication
48	Reserved (always set to 0)
49	Reserved (always set to 0)
50	Reserved (always set to 0)
51	Reserved (always set to 0)
52	Reserved (always set to 0)
53	Reserved (always set to 0)
54	Reserved (always set to 0)
55	Extension available

Table E-15: Byte 15 -- User Diagnostics

Bit	Indication
56	Undefined (A000)
57	Core EEPROM checksum error (A001)
58	RAM test error (A002)
59	Sensor not responding (no tube interrupt) (A003)
60	Temperature sensor out-of-range (A004)
61	Input over-range (A005)
62	Transmitter not characterized (A006)
63	Reserved (A037)

Table E-16: Byte 16 -- User Diagnostics

Bit	Indication
64	Density outside limits (A008)
65	Transmitter initializing/warming up (A009)
66	Calibration failure (A010)
67	Excess calibration correction, zero too low (A011)
68	Excess calibration correction, zero too high (A012)
69	Process too noisy to perform auto zero (A013)
70	Transmitter failed (A014)
71	Reserved (A015)

Table E-17: Byte 17 -- User Diagnostics

Bit	Indication
72	Line RTD temperature out-of-range (A016)
73	Meter RTD temperature out-of-range (A017)
74	Reserved (A018)
75	Reserved (A019)
76	Calibration factors unentered (A020)
77	Unrecognized/unentered sensor type (A021)
78	Reserved (A022)
79	Reserved (A023)

Table E-18: Byte 18 -- User Diagnostics

Bit	Indication
80	Reserved (A024)
81	Reserved (A025)
82	Sensor/xmtr communication failure (A026)
83	Reserved (A027)
84	Sensor/xmtr write failure (A028)
85	Internal communication failure (A029)
86	Hardware/software incompatible (A030)
87	Low power (A031)

Table E-19: Byte 19 -- User Diagnostics

Bit	Indication
88	Meter verification fault alert (A032)
89	Sensor OK/tubes stopped by process (A033)
90	Undefined (A034)
91	Meter Verification aborted (A035)
92	Undefined(A036)
93	Undefined (A037)
94	Undefined (A038)
95	Undefined(A039)

Table E-20: Byte 20 -- User Diagnostics

Bit	Indication
96	Reserved (A100)
97	Reserved (A101)
98	Drive over range/partially full tube (A102)
99	Data loss possible (A103)
100	Calibration in progress (A104)
101	Two-phase (slug flow) (A105)
102	Reserved (A106)
103	Power reset occurred (A107)

Table E-21: Byte 21 -- User Diagnostics

Bit	Indication
104	Reserved (A108)
105	Reserved (A109)
106	Reserved (A110)
107	Reserved (A111)
108	Reserved (A112)
109	Reserved (A113)
110	Reserved (A114)
111	Reserved (A115)

Table E-22: Byte 22 -- User Diagnostics

Bit	Indication
112	Petroleum measurement: temperature out-of-limits (A116)
113	Petroleum measurement: density out-of-limits (A117)
114	Reserved (118)
115	Reserved (119)
116	Concentration measurement: Unable to fit curve data (A120)
117	Concentration measurement: Extrapolation alert (A121)
118	Reserved (122)
119	Reserved (123)

Table E-23: Byte 23 -- User Diagnostics

Bit	Indication
120	Reserved (A124)
121	Reserved (A125)
122	Reserved (A126)
123	Reserved (A127)
124	Reserved (A128)
125	Undefined (A129)
126	Reserved (A130)
127	Meter Verification Info Alert (A131)

Table E-24: Byte 24 -- User Diagnostics

Bit	Indication
128	Simulation Mode Active (A132)
129	Undefined (A133)
130	Undefined (A134)
131	Undefined (A135)
132	Undefined (A136)
133	Undefined (A137)
134	Undefined (A138)
135	Undefined (A139)

F Model 2700 PROFIBUS block parameters

This appendix describes the block parameters of the Model 2700 transmitter with PROFIBUS-PA.

The tables in this appendix have been split in two to clarify the display.

The first table contains the following columns:

Column name	Definition
Index	Index of the parameter within the block.
Parameter mnemonic	Name of the parameter used in the code.
Definition	Description of the parameter.
Default (initial) value	The value the parameter takes when a master reset occurs. For some parameters, the value is calculated based on the sensor type and conditions. These values are represented with the Calculation in the field.
Enumerated list of values / range	The list of valid values to write to an enumerated parameter. This field is not applicable for read-only parameters. Valid value ranges for variable type parameters variable type parameters are not specified.

The second table contains the following columns

Column name	Definition
Index	Index of the parameter within the block.
Parameter mnemonic	Name of the parameter used in the code.
Message types:	Below are the seven types of messages.
	Variable: Some value.
	Enum: A value from a discrete list.
	Method: The parameter initiates some action within the device.
	String: A set of ASCII characters.
	Array: A set of values.
	Record: A data structure defined by the Profibus PA Profile v3.01.
	Simple: A single variable that is characterized by a defined data type.
Data type/structure	The data type.
Size	The size of data in bytes.

Column name	Definition
Store / rate (hz)	The class of memory required or the update rate of the variable, if applicable:
	D (dynamic store): The parameter is updated periodically (Cyclic Data)
	S (static): Non-volatile data. Changing the parameter increases the static revision counter (ST_REV).
	N (non-volatile): The non-volatile parameter must be remembered through a power cycle, but it is not part of the static update code.
	N-CP (non-volatile): The non-volatile code resides in the core processor.
	Cst (constant): The parameter does not change in the device.
Access	The ability to read/write (R/W) or just read a parameter. If the parameter is read/write, the Mode that the Transducer Block requires is in parentheses. For example, 'R/W (Out of service)' indicates that the parameter is writable, but the MODE_BLK parameter must be OOS for changes to take effect.
Modbus register / coil	The associated Modbus register or coil. If there is a preceding 'R', the number is a register, while a preceding 'C' indicates a coil.

F.1 Slot identification

The following table shows the slot assignment for blocks.

Table F-1: Block slot assignment

Slot	Assigned block
0	Physical block
1	Analog input block 1 -- Composite Directory
2	Analog input block 2
3	Analog input block 3
4	Totalizer block 1
5	Analog input block 4
6	Totalizer block 2
7	Totalizer block 3
8	Totalizer block 4
9	Analog output block 1
10	Analog output block 2
11	Transducer block 1
12	Transducer block 2

F.2 Physical block

The following tables show the parameters for the physical block, including the default value. If an enumerated list of values or range is not cited, there is no value for the parameter.

Physical block: standard parameters (16 through 23)

The first table focuses on definitions, default values, and the enumerated list of values allowed for each parameter, while [Table F-3](#) provides the Modbus register column and other relevant values.

Table F-2: Physical block parameters -- standard parameters (16 through 23) -- definitions, defaults, and range of values

Index	Parameter Mnemonic Standard Parameters	Definition	Default value	Enumerated list of values /range
16	BLOCK_OBJECT	This object contains the characteristics of the block.	----	NA
17	ST_REV	A block has static block parameters that are not changed by the process. Values are assigned to this parameter during the configuration of optimization. The value of ST_REV increases by 1 after every change of a static block parameter.	0	NA
18	TAG_DESC	Every block can be assigned a textual TAG description. The TAG_DESC must be unambiguous and unique in the field bus system.	''	NA
19	STRATEGY	Grouping of function block. The STRATEGY field can be used to group blocks.	0	NA
20	ALERT_KEY	This parameter contains the identification number of the plant unit.	0	NA
21	TARGET_MODE	This parameter contains desired mode normally set by a control application of an operator. The modes are valid alternatively only; for example, only one mode can be set at one time. A write access to this parameter with more than one mode is out of the range of the parameter and has to be rejected.	AUTO (*0x08)	AUTO (*0x08)

Table F-2: Physical block parameters -- standard parameters (16 through 23) -- definitions, defaults, and range of values (continued)

Index	Parameter Mnemonic Standard Parameters	Definition	Default value	Enumerated list of values /range
22	MODE_BLK	This parameter contains the current mode and the permitted and normal mode of the block.	---	NA
23	ALARM_SUM	This parameter contains the current states of the block alarms.	0,0,0,0	NA

Table F-3: Physical block parameters -- standard parameters (16 through 23) -- size, access, and Modbus register columns

Index	Parameter Mnemonic Standard Parameters	Message type	Data type/ structure	Size	Store/ rate (hz)	Access	Modbus register / coil
16	BLOCK_OBJECT	RECORD	DS-32	20	Cst	R	NA
17	ST_REV	Simple	Unsigned16	2	N	R	NA
18	TAG_DESC	Simple	Visible SIMP	32	S	R/W	NA
19	STRATEGY	Simple	Unsigned16	2	S	R/W	NA
20	ALERT_KEY	Simple	Unsigned8	1	S	R/W	NA
21	TARGET_MODE ⁽¹⁾	Simple	Unsigned8	1	S	R/W	NA
22	MODE_BLK	RECORD	DS-37	3	D	R	NA
23	ALARM_SUM	RECORD	DS-42	8	D	R	NA

(1) The enumerated list of values for this parameter is AUTO (0x8).

Physical block parameters (24 through 48)

The following tables show the physical block parameters for the physical block 24 through 48). The first table focuses on definitions, default values, and the enumerated list of values allowed for each parameter, while [Table F-5](#) provides the Modbus register column another relevant values.

Table F-4: Physical block parameters (24 through 48) -- definitions, defaults, and range of values

Index	Parameter Mnemonic Standard Parameters	Definition	Default value	Enumerated list of values /range
24	SOFTWARE _REVISION (DD Name: Software Revision)	Revision-number of the software of the field device.	----	NA
25	HARDWARE _REVISION (DD Name: Hardware Revision)	Revision-number of the hardware of the field device.	1.0	NA
26	DEVICE_MAN_ID (DD Name: Manufacturing ID)	Identification code of the manufacturer of the field device.	----	NA
27	DEVICE_ID (DD Name: Device ID)	Manufacturer specific identification of the device.	----	NA
28	DEVICE_SER _NUM (DD Name: PB Serial Number)	Serial number of the field device.	----	NA

Table F-4: Physical block parameters (24 through 48) -- definitions, defaults, and range of values (continued)

Index	Parameter Mnemonic Standard Parameters	Definition	Default value	Enumerated list of values /range
29	DIAGNOSIS (DD Name: Physical Block Diagnosis)	Detailed information of the device, bitwise coded. More than one message possible at once. If MSB of byte 4 is set to 1, then more diagnostic information is available in the DIAGNOSIS_EXTENSION parameter.	----	Refer byte 11 to 14 of Extended Diagnostics bytes in Slave diagnostic response bytes .
30	EMPTY			
31	DIAGNOSIS_MASK (DD Name: Diagnosis Mask)	Definition of supported DIAGNOSIS information-bits.	----	Out of Mandatory Alarms out of 4 Octets only Ident No. violation Alarm is supported. Extension Available Alarm is supported 0: not supported 1: supported
32	EMPTY			
33	EMPTY			
34	EMPTY			
35	EMPTY			
36	Reserved			
37	Reserved			

Table F-4: Physical block parameters (24 through 48) -- definitions, defaults, and range of values (continued)

Index	Parameter Mnemonic Standard Parameters	Definition	Default value	Enumerated list of values /range
38	DEVICE_INSTALL_DATE (DD name:- Device Install Date)	Device Installation Date	Blank	
40	IDENT_NUMBER_SELECTOR (DD Name: Ident Number)	Each PROFIBUS-DP /IEC 61158/ device shall have an Ident_Number provided by the PNO. There are profile specific Ident_Numbers. A device may have profile-specific and manufacturer-specific ones. The user is able to choose one of these using this parameter.	----	0: profile specific Ident_Number V3.01 (mandatory) 1: manufacturer specific Ident_Number V3.01
42	FEATURE (DD Name: phys Feature)	Indicates optional features implemented in the device and the status of these Features which indicates whether the feature is supported or not supported.	0x03 0x00 0x00 0x00 0x02 0x00 0x00 0x00	PROFIBUS Specification June 2005 Order No: 3.042 Amendment 2 to the Profibus Profile for Process Control Devices V 3.01 Condensed Status and Diagnostic Messages V 1.0

Table F-4: Physical block parameters (24 through 48) -- definitions, defaults, and range of values (continued)

Index	Parameter Mnemonic Standard Parameters	Definition	Default value	Enumerated list of values /range
43	COND_STATUS _DIAG (DD Name: Condensed Status)	Condensed Status Diagnostics	0	0: Status and Diagnosis is provided as defined in -PROFIBUS Profile: “PROFIBUS-PA Profile for Process Control Devices” V3.01,December 2004. PNO-Order-No. 3.042 1: Condensed Status and Diagnosis information is provided.
44	Reserved			
45	Reserved			
46	EMPTY			
47	Reserved			
48	Physical Block Views			

Table F-5: Physical block parameters (24 through 48) -- size, access, and Modbus register columns

Index	Parameter Mnemonic Standard Parameters	Msg type	Data type/ structure	Size	Store/ rate (hz)	Access	Modbus register / coil
24	SOFTWARE_REVISION (DD Name: Software Revision)	Simple	Visible string	16	Cst	R	R-1200

Table F-5: Physical block parameters (24 through 48) -- size, access, and Modbus register columns (continued)

Index	Parameter Mnemonic Standard Parameters	Msg type	Data type/ structure	Size	Store/ rate (hz)	Access	Modbus register / coil
25	HARDWARE_REVISION (DD Name: Hardware Revision)	Simple	Visible string	16	Cst	R	Hard coded
26	DEVICE_MAN_ID (DD Name: Manufacturing ID)	Simple	Unsigned16	2	Cst	R	R-121
27	DEVICE_ID (DD Name: Device ID)	Simple	Visible string	16	Cst	R	2545-2554
28	DEVICE_SER_NUM (DD Name: PB Serial Number)	Simple	Visible string	16	Cst	R	R48-49
29	DIAGNOSIS (DD Name: Physical Block Diagnosis)	Simple	Octet String byte 4, MSB=1 more diagnosis available	4	D	R	NA
30	EMPTY						
31	DIAGNOSIS_MASK (DD Name: Diagnosis Mask)	Simple	Octet string	4	Cst	R	Hard Coded 1. 0x00 2. 0x80 3. 0x00 4. 0x80
32	EMPTY						
33	EMPTY						
34	EMPTY						

Table F-5: Physical block parameters (24 through 48) -- size, access, and Modbus register columns (continued)

Index	Parameter Mnemonic Standard Parameters	Msg type	Data type/ structure	Size	Store/ rate (hz)	Access	Modbus register / coil
35	EMPTY						
36	Reserved						
37	Reserved						
38	DEVICE_INSTALL_DATE (DD name:- Device Install Date)	Simple	Octet string	16	S	R/W	2278-2285
40	IDENT_NUMBER_SELECTOR (DD Name: Ident Number)	Simple	Unsigned8	1	S	R/W	R2274
42	FEATURE (DD Name: phys Feature)	RECORD	DS-68	8	N	R	NA
43	COND_STATUS_DIAG (DD Name: Condensed Status)	Simple	Unsigned8	1	S	R/W	NA
44	Reserved						
45	Reserved						
46	Reserved						
47	Reserved						
48	Reserved						
49	Physical block views						

F.2.1 Physical block object and views

Physical block object

The following tables show the physical block object.

- Physical block object: [Table F-6](#)
- Physical block view #1: [Table F-7](#)
- Physical block view #2: [Table F-8](#)

Table F-6: Physical block object

Slot /Index	Element name	Data type	Size in bytes	Value
Slot 0	Reserved	Unsigned 8	1	250 (default)
/Index 16	Block_Object	Unsigned 8	1	01
	Parent_Class	Unsigned 8	1	01
	Class	Unsigned 8	1	250 (default)
	DD_Reference	Unsigned 32	4	00 ,00, 00, 00 (reserved)
	DD_Revision	Unsigned 16	2	00 ,00 (reserved)
	Profile	Octet string	2	64 02 (compact class B)
	Profile_Revision	Unsigned 16	2	03 01 (3.01)
	Execution_Time	Unsigned 8	1	00 (for future use)
	Number-Of_Parameters	Unsigned 16	2	00 26 (Maximum number of Physical Block Parameters)
	Address_of_View_1	Unsigned 16	2	00 49 (slot, index)
	Number_of_VIEWS	Unsigned 8	1	01 (1 view)

Physical block views

The following tables show the physical block views.

Table F-7: Physical block view #1

OD index	Parameter mnemonic -- standard parameters	View 1	View 2	View 3	View 4
16	BLOCK_OBJECT				
17	ST_REV	2			
18	TAG_DESC				
19	STRATEGY				
20	ALERT_KEY				

Table F-7: Physical block view #1 (continued)

OD index	Parameter mnemonic -- standard parameters	View 1	View 2	View 3	View 4
21	TARGET_MODE				
22	MODE_BLK	3			
23	ALARM_SUM	8			
	Overall sum of bytes in View Object	13			

Table F-8: Physical block view #2

OD index	Parameter mnemonic -- standard parameters	View 1	View 2	View 3	View 4
29	DIAGNOSIS	4			
	Overall sum of bytes in View Object (+ 13 Standard parameters bytes)	4 + 13			

F.2.2 Transducer block 1 (measurement, calibration, and diagnosis)

The following tables show the parameters for transducer block 1.

Transducer block 1 standard PA parameters (0-7)

The first table focuses on definitions, default values, and the enumerated list of values allowed for each parameter (0-7), while [Table F-10](#) provides the Modbus register column and other relevant values.

Table F-9: Transducer block 1 standard PA parameters -- definitions, defaults, and range of values

Index	Parameter Mnemonic Standard Parameters	Definition	Default value	Enumerated list of values /range
0	BLOCK_OBJECT	This object contains the characteristics of the block.	----	NA
1	ST_REV	A block has static block parameters that are not changed by the process. Values are assigned to this parameter during the configuration of optimization. The value of ST_REV increases by 1 after every change of a static block parameter.	0	NA

Table F-9: Transducer block 1 standard PA parameters -- definitions, defaults, and range of values (continued)

Index	Parameter Mnemonic Standard Parameters	Definition	Default value	Enumerated list of values /range
2	TAG_DESC	Every block can be assigned a textual TAG description. The TAG_DESC must be unambiguous and unique in the field bus system.	''	NA
3	STRATEGY	Grouping of function block. The STRATEGY field can be used to group blocks.	0	NA
4	ALERT_KEY	This parameter contains the identification number of the plant unit.	0	NA
5	TARGET_MODE	This parameter contains desired mode normally set by a control application of an operator. The modes are valid alternatively only; for example, only one mode can be set at one time. A write access to this parameter with more than one mode is out of the range of the parameter and has to be rejected.	AUTO (*0x08)	AUTO (0x8)
6	MODE_BLK	This parameter contains the current mode and the permitted and normal mode of the block.	---	NA
7	ALARM_SUM	This parameter contains the current states of the block alarms.	0,0,0,0	NA

Table F-10: Transducer block 1 standard PA parameters -- size, access, and Modbus register columns

Index	Parameter Mnemonic Standard Parameters	Message type	Data type/ structure	Size	Store/ rate (hz)	Access	Modbus register /coil
0	BLOCK_OBJECT	RECORD	DS-32	20	Cst	R	NA
1	ST_REV	Simple	Unsigned16	2	N	R	NA
2	TAG_DESC	Simple	OCTET STRING	32	S	R/W	NA

Table F-10: Transducer block 1 standard PA parameters -- size, access, and Modbus register columns (continued)

Index	Parameter Mnemonic Standard Parameters	Message type	Data type/ structure	Size	Store/ rate (hz)	Access	Modbus register /coil
3	STRATEGY	Simple	Unsigned16	2	S	R/W	NA
4	ALERT_KEY	Simple	Unsigned8	1	S	R/W	NA
5	TARGET_MODE	Simple	Unsigned8	1	S	R/W	NA
6	MODE_BLK	RECORD	DS-37	3	D	R	NA
7	ALARM_SUM	RECORD	DS-42	8	D	R	NA

Transducer block 1: standard flow parameters (8-30)

The first table focuses on definitions, default values, and the enumerated list of values allowed for each parameter (8-30), while [Table F-12](#) provides the Modbus register column and other relevant values.

Table F-11: Transducer block 1 standard flow transducer block parameters -- definitions, defaults, and range of values

Index	Parameter mnemonic standard flow transducer block parameters	Definition	Default value	Enumerated list of values /range
8	CALIBR_FACTOR (DD Name : Flow Cal Factor)	Gain compensation value for the flow sensor, so that flow indication is accurate as specified by the manufacturer.	---	NA
9	LOW_FLOW_CUTOFF (DD Name : Mass Flow Cutoff)	Mass Flow can have an hysteresis. If the value has a hysteresis, this parameter defines the lower switching point. The unit of this value is the mass flow units	0	NA

Table F-11: Transducer block 1 standard flow transducer block parameters -- definitions, defaults, and range of values (continued)

Index	Parameter mnemonic standard flow transducer block parameters	Definition	Default value	Enumerated list of values /range
10	MEASUREMENT_MODE (DD Name: Measurement Mode)	Mode of flow measurement	0	0 = Forward Only 1 = Reverse Only 2 = Bi-Directional 3 = Absolute Value 4 = Negate/Forward Only 5 = Negate /Bi-Directional
11	FLOW_DIRECTION (DD Name : Flow Direction)	Assigns an arbitrary positive or negative sign to the mass flow value	0	0 = positive 1 = negative
12	ZERO_POINT (DD Name: Zero Point)	Offset compensation value for the flow sensor, so that true zero flow value can be indicated during no flow condition	----	NA
13	ZERO_POINT_ADJUST (DD Name: Zero Calibration)	Initiates a device specific adjustment cycle that determines the true ZERO_POINT value during no flow process conditions. The result is shown in ZERO_POINT	0	0 = cancel 1 = execute
14	ZERO_POINT_UNIT (DD Name: Zero Point Unit)	Selected unit code for ZERO_POINT parameter	1057 = microse conds	1057 = microseconds
15	NOMINAL_SIZE (DD Name: Nominal Size)	Ideal size of the measuring pipe or process pipe size for insertion type flow transmitter	----	NA

Table F-11: Transducer block 1 standard flow transducer block parameters -- definitions, defaults, and range of values (continued)

Index	Parameter mnemonic standard flow transducer block parameters	Definition	Default value	Enumerated list of values /range
16	NOMINAL_SIZE_UNITS (DD Name: Nominal Size Units)	Selects the units for the NOMINAL_SIZE parameter	1019	1019 = inch
17	VOLUME_FLOW (DD Name : Volume Flow Rate)	Measure volume flow. This is an optional parameter for this device	----	NA

Table F-11: Transducer block 1 standard flow transducer block parameters -- definitions, defaults, and range of values (continued)

Index	Parameter mnemonic standard flow transducer block parameters	Definition	Default value	Enumerated list of values /range
18	VOLUME_FLOW_UNITS (DD Name : Volume Flow Units)	Selected unit code for VOLUME_FLOW, VOLUME_FLOW_LO_LIMIT and VOLUME_FLOW_HI_LIMIT	1349	0000 = None 1347 = m ³ /s 1348 = m ³ /min 1349 = m ³ /hr 1350 = m ³ /day 1351 = L/s 1352 = L/min 1353 = L/hr 1355 = Ml/day 1356 = CFS 1357 = CFM 1358 = CFH 1359 = ft ³ /day 1362 = gal/s 1363 = GPM 1364 = gal/hour 1365 = gal/day 1366 = Mgal/day 1367 = ImpGal/s 1368 = ImpGal/min 1369 = ImpGal/hr 1370 = Impgal/day 1371 = bbl/s 1372 = bbl/min

Table F-11: Transducer block 1 standard flow transducer block parameters -- definitions, defaults, and range of values (continued)

Index	Parameter mnemonic standard flow transducer block parameters	Definition	Default value	Enumerated list of values /range
				1373 = bbl/hr 1374 = bbl/day 1642 = beer bbl/s 1643 = beer bbl/min 1644 = beer bbl/hr 1645 = beer bbl/day
19	PA_VOLUME_FLOW_LO_LIMIT (DD Name : Volume Flow Low Limit)	Absolute value of the lower range volume flow of the sensor	---	
20	PA_VOLUME_FLOW_HI_LIMIT (DD Name : Volume Flow High Limit)	Absolute value of the upper range volume flow of the sensor	----	
21	MASS_FLOW (DD Name : Mass Flow Rate)	Measure mass flow. This is the Primary Variable (PV) for this device	----	NA

Table F-11: Transducer block 1 standard flow transducer block parameters -- definitions, defaults, and range of values (continued)

Index	Parameter mnemonic standard flow transducer block parameters	Definition	Default value	Enumerated list of values /range
22	MASS_FLOW_UNITS (DD Name : Mass Flow Units)	Selected unit code for MASS_FLOW, MASS_FLOW_LO_LIMIT and MASS_FLOW_HI_LIMIT	1322	1318 = g/s 1319 = g/min 1320 = g/hr 1322 = kg/s 1323 = kg/min 1324 = kg/hr 1325 = kg/day 1327 = t/min 1328 = t/h 1329 = t/d 1330 = lb/s 1331 = lb/min 1332 = lb/hr 1333 = lb/day 1335 = Ston/min 1336 = Ston/hr 1337 = Ston/day 1340 = Lton/hr 1341 = Lton/day
23	PA_MASS_FLOW_LO_LIMIT (DD Name : Mass Flow Low Limit)	Absolute value of the lower range mass flow of the sensor	---	

Table F-11: Transducer block 1 standard flow transducer block parameters -- definitions, defaults, and range of values (continued)

Index	Parameter mnemonic standard flow transducer block parameters	Definition	Default value	Enumerated list of values /range
24	PA_MASS_FLOW_HI_LIMIT (DD Name : Mass Flow High Limit)	Absolute value of the upper range mass flow of the sensor	---	
25	DENSITY (DD Name : Density)	Measure density. This is the Secondary Variable (SV) for this device.	----	
26	DENSITY_UNITS (DD Name : Density Units)	Selected unit code for DENSITY, DENSITY_LO_LIMIT and DENSITY_HI_LIMIT	1103	0000 = None 1097 = kg/m ³ 1100 = g/cm ³ 1103 = kg/L 1104 = g/m 1105 = g/L 1106 = lb/in ³ 1107 = lb/ft ³ 1108 = lb/gal 1109 = Ston/yd ³ 31113 = DegAPI 1114 = SGU

Table F-11: Transducer block 1 standard flow transducer block parameters -- definitions, defaults, and range of values (continued)

Index	Parameter mnemonic standard flow transducer block parameters	Definition	Default value	Enumerated list of values /range
27	PA_DENSITY _LOW_LIMIT (DD Name : Density Low Limit)	Absolute value of the lower range density of the sensor	----	
28	PA_DENSITY _HI_LIMIT (DD Name : Density High Limit)	Absolute value of the upper range density of the sensor	----	
29	TEMPERATURE (DD Name : Temperature)	Measure temperature. This is the Tertiary Variable (TV) for this device	----	
30	TEMPERATURE _UNITS (DD Name : Temperature Units)	Selected unit code for TEMPERATURE, TEMPERATURE_LO_LIMIT and TEMPERATURE_HI_LIMIT	1000	0000 = None 1000 = K 1001 = Deg C 1002 = Deg F 1003 = Deg R
31	PA_TEMPERATURE _LOW_LIMIT (DD Name : Temperature Low Limit)	Absolute value of the lower range temperature of the sensor	----	

Table F-11: Transducer block 1 standard flow transducer block parameters -- definitions, defaults, and range of values (continued)

Index	Parameter mnemonic standard flow transducer block parameters	Definition	Default value	Enumerated list of values /range
32	PA_TEMPERATURE_HI_LIMIT (DD Name : Temperature High Limit)	Absolute value of the upper range temperature of the sensor	----	

Table F-12: Transducer block 1 standard flow transducer block parameters -- size, access, and Modbus register columns

Index	Parameter mnemonic standard flow transducer block parameters	Message type	Data type/structure	Size	Store/rate (hz)	Access	Modbus register / coil
8	CALIBR_FACTOR (DD Name : Flow Cal Factor)	Simple	Float	4	S	R/W	R-0407
9	LOW_FLOW_CUTOFF (DD Name : Mass Flow Cutoff)	Simple	Float	4	S	R/W	R-0195
10	MEASUREMENT_MODE (DD Name: Measurement Mode)	Simple	Unsigned8	1	S	R/W	R-0017

Table F-12: Transducer block 1 standard flow transducer block parameters -- size, access, and Modbus register columns (continued)

Index	Parameter mnemonic standard flow transducer block parameters	Message type	Data type/structure	Size	Store/rate (hz)	Access	Modbus register / coil
11	FLOW_DIRECTION (DD Name : Flow Direction)	Simple	Unsigned8	1	S	R/W	NA
12	ZERO_POINT (DD Name: Zero Point)	Simple	Float	4	S	R/W	R-0233
13	ZERO_POINT_ADJUST (DD Name: Zero Calibration)	Simple	Unsigned8	1	N	R/W	NA
14	ZERO_POINT_UNIT (DD Name: Zero Point Unit)	Simple	Unsigned16	2	S	R/W	NA
15	NOMINAL_SIZE (DD Name: Nominal Size)	Simple	Float	4	S	R/W	NA
16	NOMINAL_SIZE_UNITS (DD Name: Nominal Size Units)	Simple	Unsigned16	2	S	R/W	NA

Table F-12: Transducer block 1 standard flow transducer block parameters -- size, access, and Modbus register columns (continued)

Index	Parameter mnemonic standard flow transducer block parameters	Message type	Data type/structure	Size	Store/rate (hz)	Access	Modbus register / coil
17	VOLUME_FLOW (DD Name : Volume Flow Rate)	RECORD	101	5	D	R/W	NA
18	VOLUME_FLOW_UNITS (DD Name : Volume Flow Units)	Simple	Unsigned16	2	S	R/W	R-0042
19	PA_VOLUME_FLOW_LO_LIMIT (DD Name : Volume Flow Low Limit)	Simple	Float	4	S	R/W	
20	PA_VOLUME_FLOW_HI_LIMIT (DD Name : Volume Flow High Limit)	Simple	Float	4	S	R/W	
21	MASS_FLOW (DD Name : Mass Flow Rate)	RECORD	101	5	D	R	R-0247

Table F-12: Transducer block 1 standard flow transducer block parameters -- size, access, and Modbus register columns (continued)

Index	Parameter mnemonic standard flow transducer block parameters	Message type	Data type/structure	Size	Store/rate (hz)	Access	Modbus register / coil
22	MASS_FLOW_UNITS (DD Name : Mass Flow Units)	Simple	Unsigned16	2	S	R/W	R-0039
23	PA_MASS_FLOW_LOW_LIMIT (DD Name : Mass Flow Low Limit)	Simple	Float	4	S	R/W	
24	PA_MASS_FLOW_HI_LIMIT (DD Name : Mass Flow High Limit)	Simple	Float	4	S	R/W	
25	DENSITY (DD Name : Density)	RECORD	101	5	D	R	R-0003
26	DENSITY_UNITS (DD Name : Density Units)	Simple	Unsigned16	2	S	R/W	R-0040

Table F-12: Transducer block 1 standard flow transducer block parameters -- size, access, and Modbus register columns (continued)

Index	Parameter mnemonic standard flow transducer block parameters	Message type	Data type/structure	Size	Store/rate (hz)	Access	Modbus register / coil
27	PA_DENSITY _LOW_LIMIT (DD Name : Density Low Limit)	Simple	Float	4	S	R/W	
28	PA_DENSITY _HI_LIMIT (DD Name : Density High Limit)	Simple	Float	4	S	R/W	
29	TEMPERATURE (DD Name : Temperature)	RECORD	101	5	D	R	R-251
30	TEMPERATURE _UNITS (DD Name : Temperature Units)	Simple	Unsigned16	2	S	R/W	R-0041
31	PA_TEMPERATUR E _LO_LIMIT (DD Name : Temperature Low Limit)	Simple	Float	4	S	R/W	

Table F-12: Transducer block 1 standard flow transducer block parameters -- size, access, and Modbus register columns (continued)

Index	Parameter mnemonic standard flow transducer block parameters	Message type	Data type/structure	Size	Store/rate (hz)	Access	Modbus register / coil
32	PA_TEMPERATUR E _HI_LIMIT (DD Name : Temperature High Limit)	Simple	Float	4	S	R/W	

Transducer block 1: manufacturer-specific variables (33-48)

The first table focuses on definitions, default values, and the enumerated list of values allowed for each parameter (33-48), while [Table F-14](#) provides the Modbus register column and other relevant values.

Table F-13: Transducer block 1 manufacturer-specific parameters -- definitions, defaults, and range of values

Index	Parameter mnemonic manufacturer specific parameters	Definition	Default value	Enumerated list of values /range
33	SNS_Damping FlowRate (DD Name : Flow Damping)	Flow rate (Mass and Volume) internal damping (seconds)	0.8	0.0 to 60.0 sec
34	SNS_DampingTemp (DD Name : Temperature Damping)	Temperature internal damping (seconds)	4.8	0.0 to 80.0 sec

Table F-13: Transducer block 1 manufacturer-specific parameters -- definitions, defaults, and range of values (continued)

Index	Parameter mnemonic manufacturer specific parameters	Definition	Default value	Enumerated list of values /range
35	SNS_Damping Density (DD Name : Density Damping)	Density internal damping (seconds)	1.6	N/A/0.0 to 60.0 sec
36	SNS_MassMeter Factor (DD Name : Mass Factor)	Mass Rate Factor	1.0	0.8 to 1.2
37	SNS_DensMeter Factor (DD Name : Density Factor)	Density Factor	1.0	0.8 to 1.2
38	SNS_VolMeter Factor (DD Name : Volume Factor)	Volume Rate Factor	1.0	0.8 to 1.2
39	SNS_VolumeFlow Cutoff (DD Name : Volume Cutoff)	Volume flow cutoff for internal totalizers	0.0-	0 to sensor limit
40	SNS_LowDensity Cutoff (DD Name : Density Cutoff)	Density cutoff for internal totalizers	0.0-	0.0 to 0.5
41	EMPTY			

Table F-13: Transducer block 1 manufacturer-specific parameters -- definitions, defaults, and range of values (continued)

Index	Parameter mnemonic manufacturer specific parameters	Definition	Default value	Enumerated list of values /range
42	EMPTY			
43	EMPTY			
44	EMPTY			
45	EMPTY			
46	EMPTY			
47	EMPTY			
48	EMPTY			

Table F-14: Transducer block 1 manufacturer-specific parameters -- size, access, and Modbus register columns

Index	Parameter mnemonic manufacturer specific parameters	Message type	Data type/ structure	Size	Store/ rate (hz)	Access	Modbus register / coil
33	SNS_Damping FlowRate (DD Name : Flow Damping)	VARIABLE	Float	4	N-CP	R/W	R-189-190
34	SNS_Damping Temp (DD Name : Temperature Damping)	VARIABLE	Float	4	N-CP	R/W	R-191-192

Table F-14: Transducer block 1 manufacturer-specific parameters -- size, access, and Modbus register columns (continued)

Index	Parameter mnemonic manufacturer specific parameters	Message type	Data type/ structure	Size	Store/ rate (hz)	Access	Modbus register / coil
35	SNS_Damping Density (DD Name : Density Damping)	VARIABLE	Float	4	N-CP	R/W	R-193-194
36	SNS_MassMeter Factor (DD Name : Mass Factor)	VARIABLE	Float	4	N-CP	R/W	R-279-280
37	SNS_DensMeter Factor (DD Name : Density Factor)	VARIABLE	Float	4	N-CP	R/W	R-283-284
38	SNS_VolMeter Factor (DD Name : Volume Factor)	VARIABLE	Float	4	N-CP	R/W	R-281-282
39	SNS_VolumeFlow Cutoff (DD Name : Volume Cutoff)	VARIABLE	Float	4	N-CP	R/W	R-197-198
40	SNS_LowDensity Cutoff (DD Name : Density Cutoff)	VARIABLE	Float	4	N-CP	R/W	R-149-150
41	EMPTY						

Table F-14: Transducer block 1 manufacturer-specific parameters -- size, access, and Modbus register columns (continued)

Index	Parameter mnemonic manufacturer specific parameters	Message type	Data type/ structure	Size	Store/ rate (hz)	Access	Modbus register / coil
42	EMPTY						
43	EMPTY						
44	EMPTY						
45	EMPTY						
46	EMPTY						
47	EMPTY						
48	EMPTY						

Transducer block 1: totalizers (49-61)

The first table focuses on definitions, default values, and the enumerated list of values allowed for each parameter (49-61), while [Table F-16](#) provides the Modbus register column and other relevant values.

Table F-15: Transducer block 1 totalizers -- definitions, defaults, and range of values

Index	Parameter mnemonic totalizer-specific parameters	Definition	Default value	Enumerated list of values /range
49	EMPTY			
50	EMPTY			
51	EMPTY			
52	EMPTY			
53	EMPTY			
54	SNS_MassTotal (DD Name : Mass Total)	Mass Total	0	N/A

Table F-15: Transducer block 1 totalizers -- definitions, defaults, and range of values (continued)

Index	Parameter mnemonic totalizer-specific parameters	Definition	Default value	Enumerated list of values /range
55	SSNS_VolTotal (DD Name : Volume Total)	Volume Total	0	N/A
56	SNS_MassInventory (DD Name : Mass Inventory)	Mass Inventory	0	N/A
57	SNS_VolInventory (DD Name : Volume Inventory)	Volume Inventory	0	N/A
58	SNS_MassTotalUnits (DD Name: Mass Total/Inv Units)	Standard or special mass total and mass inventory unit	g/s	0000 = None 1088 = Kg 1089 = g 1092 = metric tons 1094 = lbs 1095 = short tons 1096 = long tons

Table F-15: Transducer block 1 totalizers -- definitions, defaults, and range of values (continued)

Index	Parameter mnemonic totalizer-specific parameters	Definition	Default value	Enumerated list of values /range
59	SNS_VolTotalUnits (DD Name: Volume Total/Inv Units)	Standard or special volume total or mass inventory unit	l/s	0000 = None 1034 = m ³ 1036 = cm ³ 1038 = l 1043 = ft ³ 1048 = gal 1049 = ImpGal 1051 = bbl 1641 = Beer bbl
60	SNS_ResetMassInv (DD Name: Reset Mass Inventory)	Reset Mass Inventory ("On" = Reset, "Off" = N/A)	-	0X00 = None 0X01 = Reset
61	SNS_ResetVolInv (DD Name: Reset Volume Inventory)	Reset Volume Inventory ("On" = Reset, "Off" = N/A)	-	0x00 = None 0X01 = Reset

Table F-16: Transducer block 1 totalizers -- size, access, and Modbus register columns

Index	Parameter mnemonic totalizer-specific parameters	Message type	Data type/ structure	Size	Store/ rate (hz)	Access	Modbus register / coil
49	EMPTY						
50	EMPTY						
51	EMPTY						
52	EMPTY						

**Table F-16: Transducer block 1 totalizers -- size, access, and Modbus register columns
(continued)**

Index	Parameter mnemonic totalizer-specific parameters	Message type	Data type/ structure	Size	Store/ rate (hz)	Access	Modbus register / coil
53	EMPTY						
54	SNS_MassTotal (DD Name : Mass Total)	VARIABLE	101	5	D/20	R	R-0259-0260
55	SSNS_VolTotal (DD Name : Volume Total)	VARIABLE	101	5	D/20	R	R-0261-0262
56	SNS_MassInventory (DD Name : Mass Inventory)	VARIABLE	101	5	D/20	R	R-263-264
57	SNS_VolInventory (DD Name : Volume Inventory)	VARIABLE	101	5	D/20	R	R-0265-0266
58	SNS_MassTotal Units (DD Name: Mass Total/Inv Units)	ENUM	Unsigned16	2	N	R	R-0045
59	SNS_VolTotalUnits (DD Name: Volume Total/Inv Units)	ENUM	Unsigned16	2	N	R	R-0046

Table F-16: Transducer block 1 totalizers -- size, access, and Modbus register columns (continued)

Index	Parameter mnemonic totalizer-specific parameters	Message type	Data type/ structure	Size	Store/ rate (hz)	Access	Modbus register / coil
60	SNS_ResetMassInv (DD Name: Reset Mass Inventory)	METHOD	Unsigned8	1	D	R/W	Coil – 0192
61	SNS_ResetVolInv (DD Name: Reset Volume Inventory)	METHOD	Unsigned8	1	D	R/W	Coil – 0193

Transducer block 1: gas process variables (62-81)

The first table focuses on definitions, default values, and the enumerated list of values allowed for each parameter (62-81), while [Table F-18](#) provides the Modbus register column and other relevant values.

Table F-17: Transducer block 1 gas process variables -- definitions, defaults, and range of values

Index	Parameter mnemonic gas process parameters	Definition	Default value	Enumerated list of values /range
62	SNS_EnableGSV (DD Name: Enable Gas Std Volume Flow And Total)	Enable/Disable Gas Standard Volume Flow and Totals	0x00	0x00 = disabled 0x01 = enabled
63	SNS_GSV_GasDens (DD Name: Gas Std Density)	Gas Density used to calculate Reference Volume Gas Flow and Totals	0.0752 lb/ft ³	Density Sensor limits

Table F-17: Transducer block 1 gas process variables -- definitions, defaults, and range of values (continued)

Index	Parameter mnemonic gas process parameters	Definition	Default value	Enumerated list of values /range
64	SNS_GSV_VolFlow (DD Name: Gas Std Volume Flow Rate)	Reference Volume Gas Flow Rate (not valid when API or ED is enabled)	0	N/A
65	SNS_GSV_VolTot (DD Name: GSV Total)	Reference Volume Gas Total (not valid when API or ED is enabled)	0	N/A
66	SNS_GSV_VolInv (DD Name: GSV Inventory)	Reference Volume Gas Inventory (not valid when API or ED is enabled)	0	N/A

Table F-17: Transducer block 1 gas process variables -- definitions, defaults, and range of values (continued)

Index	Parameter mnemonic gas process parameters	Definition	Default value	Enumerated list of values /range
67	SNS_GSV_FlowUnits	Gas Standard Volume Flow Engineering Units	SCFM	1360 = SCFM 1361 = SCFH 1522 = Nm ³ /s 1523 = Nm ³ /m 1524 = Nm ³ /h 1525 = Nm ³ /d 1527 = Sm ³ /s 1528 = Sm ³ /m 1529 = Sm ³ /h 1530 = Sm ³ /d 1532 = NL/s 1533 = NL/m 1534 = NL/h 1535 = NL/d 1537 = SL/s 1538 = SL/m 1539 = SL/h 1540 = SL/d 1604 = SCFS 1605 = SCFD

Table F-17: Transducer block 1 gas process variables -- definitions, defaults, and range of values (continued)

Index	Parameter mnemonic gas process parameters	Definition	Default value	Enumerated list of values /range
68	SNS_GSV_TotalUnits (DD Name: GSV Total /Inv Units)	Gas Standard Volume Total and Inventory Engineering Unit	SCF	0000 = None 1053 = SCF 1521 = Nm ³ 1526 = Sm ³ 1531 = NL 1536 = SL
69	SNS_GSV_FlowCutoff (DD Name: Gas Std Vol Flow Cutoff)	Gas Standard Volume Low Flow Cutoff	---	Must be >= 0.0
70	SNS_ResetGSVolTotal (DD Name: Reset Gas Std Volume Total)	Reset Gas Standard Volume Total ("On" = Reset, "Off" = N/A)	---	0x00 = No Effect 0x01 = Reset
71	SNS_ResetAPIGSVInv (DD Name: Reset Gas Std Volume Inventory)	Reset API/GSV Inventory ("On" = Reset, "Off" = N/A)	0x00	0x00 = No Effect 0x01 = Reset
72	FRF_StartMeterVer (DD Name: Start On-Line Meter Verification)	Start On-Line Meter Verification	0x00	0x00 = No Effect 0x01 = Start On-Line Meter Verification
73	FRF_MV_Index	FCF Datalog Index	0x00	(0-19, 0 = most recent run)
74	FRF_MV_Counter	FCF Datalog Item 1: Run Number	0x00	

Table F-17: Transducer block 1 gas process variables -- definitions, defaults, and range of values (continued)

Index	Parameter mnemonic gas process parameters	Definition	Default value	Enumerated list of values /range
75	FRF_MV_Status	FCF Datalog Item 5: Status Abort States are compressed to fit in 3 bits	0x00	Bit7 = FCF pass/fail Bits6-4 = state, Bits3-0 = Abort code
76	FRF_MV_Time	FCF Datalog Item 2: Time Initiated (in running seconds)	0x00	N/A
77	FRF_MV_LPO_Norm	FCF Datalog Item 3: LPO Normalized Data	0x00	N/A
78	FRF_MV_RPO_Norm	FCF Datalog Item 4: RPO Normalized Data	0x00	N/A
79	FRF_MV_FirstRun_Time	MV Timers: Time Until First Run in Hours	0x00	N/A
80	FRF_MV_Elapse_Time	MV Timers: Time between each run after the first run initiated in hours	0x00	N/A
81	FRF_MV_Time_Left	MV Timers: Time left until next run in hours	0x00	N/A

Table F-18: Transducer block 1 gas process variables -- size, access, and Modbus register columns

Index	Parameter mnemonic gas process parameters	Message type	Data type/ structure	Size	Store/ rate (hz)	Access	Modbus register / coil
62	SNS_EnableGSV (DD Name: Enable Gas Std Volume Flow And Total)	ENUM	Unsigned8	1	S	R/W	coil-0078

Table F-18: Transducer block 1 gas process variables -- size, access, and Modbus register columns (continued)

Index	Parameter mnemonic gas process parameters	Message type	Data type/ structure	Size	Store/ rate (hz)	Access	Modbus register / coil
63	SNS_GSV _GasDens (DD Name: Gas Std Density)	VARIABLE	Float	4	N-CP	R/W	R-0453-0454
64	SNS_GSV _VolFlow (DD Name: Gas Std Volume Flow Rate)	VARIABLE	101	5	D/20	R	R-0455-0456
65	SNS_GSV_VolTot (DD Name: GSV Total)	VARIABLE	101	5	D/20	R	R-0457-0458
66	SNS_GSV_VolInv (DD Name: GSV Inventory)	VARIABLE	101	5	D/20	R	R-0459-0460
67	SNS_GSV _FlowUnits	ENUM	Unsigned16	2	S	R/W	R-2601
68	SNS_GSV _TotalUnits	ENUM	Unsigned16	2	S	R	R-2602
69	SNS_GSV _FlowCutoff	VARIABLE	Float	4	N-CP	R/W	R-461-462
70	SNS_Reset GSVolTotal (DD Name: Reset Gas Std Volume Total)	METHOD	Unsigned8	1	D	R/W	Coil-0063

Table F-18: Transducer block 1 gas process variables -- size, access, and Modbus register columns (continued)

Index	Parameter mnemonic gas process parameters	Message type	Data type/ structure	Size	Store/ rate (hz)	Access	Modbus register / coil
71	SNS_ResetAPI GSVInv (DD Name: Reset Gas Std Volume Inventory)	METHOD	Unsigned8	1	D	R/W	Coil-0194
72	FRF_Start MeterVer (DD Name: Start On-Line Meter Verification)	VARIABLE	Unsigned8	1	D	R/W	Coil – 0190
73	FRF_MV_Index	VARIABLE	Unsigned16	2	D	R/W	R-2984
74	FRF_MV_Counter	VARIABLE	Unsigned16	2	N-CP	R	R-2985
75	FRF_MV_Status	VARIABLE	Unsigned16	2	N-CP	R	R-2986
76	FRF_MV_Time	VARIABLE	Unsigned32	4	N-CP	R	R-2987–2988
77	FRF_MV _LPO_Norm	VARIABLE	Float	4	N-CP	R	R-2989–2990
78	FRF_MV _RPO_Norm	VARIABLE	Float	4	N-CP	R	R-2991–2992
79	FRF_MV _FirstRun_Time	VARIABLE	Float	4	N-CP	R/W	R-2993–2994
80	FRF_MV _Elapse_Time	VARIABLE	Float	4	N-CP	R/W	R-2995–2996
81	FRF_MV _Time_Left	VARIABLE	Float	4	D	R	R-2997–2998

Transducer block 1: calibration block variables (82-109)

The first table focuses on definitions, default values, and the enumerated list of values allowed for each parameter (82-109), while [Table F-20](#) provides the Modbus register column and other relevant values.

Table F-19: Transducer block 1 calibration block variables -- definitions, defaults, and range of values

Index	Parameter mnemonic calibration block variables	Definition	Default value	Enumerated list of values /range
82	SNS_FlowCalTempCoeff (DD Name: Flow Temp Coeff (FT))	Temperature coefficient for flow	5.13	>= 0.0
83	SNS_MaxZeroingTime (DD Name: Zero Time)	Maximum zeroing time	20	5 to 300
84	SNS_AutoZeroStdDev (DD Name: Zero Std Dev)	Standard deviation of auto zero	--	N/A
85	SNS_AutoZeroValue (DD Name: Zero Offset)	Present flow signal offset at zero flow in μ sec	--	-5.0 to 5.0
86	SNS_FailedCal (DD Name: Zero Failed Value)	Value of the zero if the zero cal failed	--	N/A
87	SNS_K1Cal (DD Name: Low Density Cal)	Perform low-density calibration	-	0x00= None 0x01 = Start Cal
88	SNS_K2Cal (DD Name: High Density Cal)	Perform high-density calibration	-	0x00= None 0x01 = Start Cal
89	SNS_FdCal (DD Name: Flowing Density Cal)	Perform flowing-density calibration	-	0x00= None 0x01 = Start Cal

Table F-19: Transducer block 1 calibration block variables -- definitions, defaults, and range of values (continued)

Index	Parameter mnemonic calibration block variables	Definition	Default value	Enumerated list of values /range
90	SNS_Tseries D3Cal (DD Name: D3 Density Cal)	Perform third point calibration	-	0x00= None 0x01 = Start Cal
91	NS_Tseries D4Cal (DD Name: D4 Density Cal)	Perform fourth point calibration	-	0x00= None 0x01 = Start Cal
92	SNS_K1 (DD Name: K1)	Density calibration constant 1 (μsec)	1000.0	1000 to 50000
93	SNS_K2 (DD Name: K2)	Density calibration constant 2 (μsec)	50000.0	1000 to 50000
94	SNS_FD (DD Name: FD)	Flowing Density calibration constant	-	>= 0.0
95	SNS_TseriesK3 (DD Name: K3)	Density calibration constant 3 (μsec)	-	0, or 1000 to 50000
96	SNS_TseriesK4 (DD Name: K4)	Density calibration constant 4 (μsec)	-	0, or 1000 to 50000
97	SNS_D1 (DD Name: D1)	Density 1 (g/cc)	-	Density Limits (and < 0.05 if T-series)
98	SNS_D2 (DD Name: D2)	Density 2 (g/cc)	1.0	Density Limits, and must be 1.0 +/-0.1 for T-series
99	SNS_CalValForFD (DD Name: FD Value)	Flowing Density (g/cc)	-	>= 0
100	SNS_TSeriesD3 (DD Name: D3)	Density 3 (g/cc)	-	Density Limits, and must be at least +/- 0.1 away from D2 and d3 > 0.6 g/cc

Table F-19: Transducer block 1 calibration block variables -- definitions, defaults, and range of values (continued)

Index	Parameter mnemonic calibration block variables	Definition	Default value	Enumerated list of values /range
101	SNS_TSeriesD4 (DD Name: D4)	Density 4 (g/cc)	-	Density Limits, and must be at least +/-0.1 away from D2 and D3 And $d3 < > 0$ and $d4 > 0.6$ g/cc
102	SNS_DensityTempCoeff (DD Name: Density Temp Coeff (DT))	Density temperature coefficient	4.44	-20.0 to 20.0
103	SNS_TSeriesFlowTGCO (DD Name: FTG)	T-Series: Flow TG Coefficient (FTG)	0.0	N/A
104	SNS_TSeriesFlowFQCO (DD Name: FFQ)	T-Series : Flow FQ Coefficient (FFQ)	0.0	N/A
105	SNS_TSeriesDensTGCO (DD Name: DTG)	T-Series: Density TG Coefficient (DTG)	0.0	N/A
106	SNS_TSeriesDensFQCO1 (DD Name: DFQ1)	T-Series: Density FQ Coefficient #1 (DFQ1)	0.0	N/A
107	SNS_TSeriesDensFQCO2 (DD Name: DFQ2)	T-Series: Density FQ Coefficient #2 (DFQ2)	0.0	N/A
108	SNS_TempCalOffset (DD Name: Temperature Offset)	Temperature calibration offset	0.0	N/A
109	SNS_TempCalSlope (DD Name: Temperature Slope)	Temperature calibration slope	1.0	N/A

Table F-20: Transducer block 1 calibration block variables -- size, access, and Modbus register columns

Index	Parameter mnemonic calibration block variables	Message type	Data type/ structure	Size	Store /rate (hz)	Access	Modbus register / coil
82	SNS_FlowCal TempCoeff (DD Name: Flow Temp Coeff (FT))	VARIABLE	Float	4	N-CP	R/W	R-409-410
83	SNS_Max ZeroingTime (DD Name: Zero Time)	VARIABLE	Unsigned16	2	N-CP	R/W	R-0136
84	SNS_Auto ZeroStdDev (DD Name: Zero Std Dev)	VARIABLE	Float	4	D	R	R-0231-232
85	SNS_Auto ZeroValue (DD Name: Zero Offset)	VARIABLE	Float	4	N-CP	R/W	R-233-234
86	SNS_FailedCal (DD Name: Zero Failed Value)	VARIABLE	Float	4	S	R	R-0235-236
87	SNS_K1Cal (DD Name: Low Density Cal)	METHOD	Unsigned8	1	D	R/W	Coil-0013
88	SNS_K2Cal (DD Name: High Density Cal)	METHOD	Unsigned8	1	D	R/W	Coil-0014
89	SNS_FdCal (DD Name: Flowing Density Cal)	METHOD	Unsigned8	1	D	R/W	Coil-0018

Table F-20: Transducer block 1 calibration block variables -- size, access, and Modbus register columns (continued)

Index	Parameter mnemonic calibration block variables	Message type	Data type/ structure	Size	Store /rate (hz)	Access	Modbus register / coil
90	SNS_Tseries D3Cal (DD Name: D3 Density Cal)	METHOD	Unsigned8	1	D	R/W	Coil-0044
91	SNS_Tseries D4Cal (DD Name: D4 Density Cal)	METHOD	Unsigned8	1	D	R/W	Coil-0045
92	SNS_K1 (DD Name: K1)	VARIABLE	Float	1	N-CP	R/W	R-159-160
93	SNS_K2 (DD Name: K2)	VARIABLE	Float	2	N-CP	R/W	R-161-162
94	SNS_FD (DD Name: FD)	VARIABLE	Float	2	N-CP	R/W	R303-304
95	NS_TseriesK3 (DD Name: K3)	VARIABLE	Float	2	N-CP	R/W	R-0503
96	SNS_TseriesK4 (DD Name: K4)	VARIABLE	Float	4	N-CP	R/W	R-0519
97	SNS_D1 (DD Name: D1)	VARIABLE	Float	4	N-CP	R/W	R-0155-0156
98	SNS_D2 (DD Name: D2)	VARIABLE	Float	4	N-CP	R/W	R-0157-0158
99	SNS_CalValForFD (DD Name: FD Value)	VARIABLE	Float	4	D	R/W	R277-278
100	SNS_TSeriesD3 (DD Name: D3)	VARIABLE	Float	4	N-CP	R/W	R-509

Table F-20: Transducer block 1 calibration block variables -- size, access, and Modbus register columns (continued)

Index	Parameter mnemonic calibration block variables	Message type	Data type/ structure	Size	Store /rate (hz)	Access	Modbus register / coil
101	SNS_TSeriesD4 (DD Name: D4)	VARIABLE	Float	4	N-CP	R/W	R-511
102	SNS_DensityTempCoeff (DD Name: Density Temp Coeff (DT))	VARIABLE	Float	4	N-CP	R/W	R-0163-164
103	SNS_TSeriesFlowTGCO (DD Name: FTG)	VARIABLE	Float	4	N-CP	R/W	R-505
104	SNS_TSeriesFlowFQCO (DD Name: FFQ)	VARIABLE	Float	4	N-CP	R/W	R-507
105	SNS_TSeriesDensTGCO (DD Name: DTG)	VARIABLE	Float	4	N-CP	R/W	R-513
106	SNS_TSeriesDensFQCO1 (DD Name: DFQ1)	VARIABLE	Float	4	N-CP	R/W	R-515
107	SNS_TSeriesDensFQCO2 (DD Name: DFQ2)	VARIABLE	Float	4	N-CP	R/W	R-517
108	SNS_TempCalOffset (DD Name: Temperature Offset)	VARIABLE	Float	4	N-CP	R/W	R-0413-0414

Table F-20: Transducer block 1 calibration block variables -- size, access, and Modbus register columns (continued)

Index	Parameter mnemonic calibration block variables	Message type	Data type/ structure	Size	Store /rate (hz)	Access	Modbus register / coil
109	SNS_Temp CalSlope (DD Name: Temperature Slope)	VARIABLE	Float	4	N-CP	R/W	R-0411-0412

Transducer block 1: temperature compensation values (110-111)

The first table focuses on definitions, default values, and the enumerated list of values allowed for each parameter (110-111), while [Table F-22](#) provides the Modbus register column and other relevant values.

Table F-21: Transducer block 1 temperature compensation variables -- definitions, defaults, and range of values

Index	Parameter mnemonic temperature compensation variables	Definition	Default value	Enumerated list of values /range
110	SNS_Enable ExtTemp (DD Name: Enable Disable Ext Temp)	Enable/Disable External Temp for API/ED (See 449/450)	0x00	0x00 = Disable 0x01 = Enable

Table F-21: Transducer block 1 temperature compensation variables -- definitions, defaults, and range of values (continued)

Index	Parameter mnemonic temperature compensation variables	Definition	Default value	Enumerated list of values /range
111	SNS_External TempInput (The data base item is the same as TEMPERATURE – index 29 parameter) (DD Name: External Temp calibration input)	External temperature calibration input	---	Temp. sensor limits

Table F-22: Transducer block 1 temperature compensation variables -- size, access, and Modbus register columns

Index	Parameter mnemonic temperature compensation variables	Msg type	Data type/ structure	Size	Store/ rate (hz)	Access	Modbus register / coil
110	SNS_Enable ExtTemp (DD Name: Enable Disable Ext Temp)	METHOD	Unsigned8	1	D	R/W	Coil-0086

Table F-22: Transducer block 1 temperature compensation variables -- size, access, and Modbus register columns (continued)

Index	Parameter mnemonic temperature compensation variables	Msg type	Data type/structure	Size	Store/rate (hz)	Access	Modbus register / coil
111	SNS_External TempInput (The data base item is the same as TEMPERATURE – index 29 parameter) (DD Name: External Temp calibration input)	RECORD	101	5	D	R/W	R-0449-0450

Transducer block 1: pressure compensation values (112-129)

The first table focuses on definitions, default values, and the enumerated list of values allowed for each parameter (112-129), while Table F-24 provides the Modbus register column and other relevant values.

Table F-23: Transducer block 1 pressure compensation variables -- definitions, defaults, and range of values

Index	Parameter mnemonic pressure compensation variables	Definition	Default value	Enumerated list of values /range
112	SNS_Enable PresComp (DD Name: Pressure Compensation Enable /Disable)	Enable/Disable Pressure Compensation	0	0x00 = Disable 0x01 = Enable

Table F-23: Transducer block 1 pressure compensation variables -- definitions, defaults, and range of values (continued)

Index	Parameter mnemonic pressure compensation variables	Definition	Default value	Enumerated list of values /range
113	SNS_ExternalPresInput (DD Name : External Pressure calibration input)	Pressure	---	0 to 10,000 bar
114	SNS_Pressure (The data base item is same as SNS_ExternalPres Inputparameter) (DD Name : External Read Pressure)	Pressure	----	

Table F-23: Transducer block 1 pressure compensation variables -- definitions, defaults, and range of values (continued)

Index	Parameter mnemonic pressure compensation variables	Definition	Default value	Enumerated list of values /range
115	SNS_PressureUnits (DD Name : Pressure Units)	Pressure Unit	g/cm3	0000 = None 1148 = inch water @ 68F 1146 = inch water @ 60F 1156 = inch HG @ 0C 1154 = ft water @ 68F 1151 = mm water @ 68F 1158 = mm HG @ 0C 1141 = psi 1137 = bar 1138 = millibar 1144 = g/cm ² 1145 = kg/cm ² 1130 = pascals 1133 = kilo pascals 1139 = torr @ 0C 1140 = atmospheres 1147 = InH2O(4C)

Table F-23: Transducer block 1 pressure compensation variables -- definitions, defaults, and range of values (continued)

Index	Parameter mnemonic pressure compensation variables	Definition	Default value	Enumerated list of values /range
				1150 = mmH2O(4C) 1132 = MPA
116	SNS_FlowPresComp (DD Name: Flow Factor)	Pressure correction factor for flow	0.0	-0.1 to 0.1
117	SNS_DensPresComp (DD Name: Density factor)	Pressure correction factor for density	0.0	-0.1 to 0.1
118	SNS_FlowCalPres (DD Name: Cal Pressure)	Flow calibration pressure	0.0	>= 0.0
119	SNS_FlowZero RestoreFactory (DD Name: Restore Factory Zero)	Restore Factory Zero		0x00 = None 0x01 = Restore
120	DB_SNS_Auto ZeroFactory	Factory flow signal offset at zero flow (units of uSec)	---	N/A
121	AO_BLK_COMP (DD: Name: AO Compensation)	The Pressure / Temp. compensation selector parameter that decides the Temp. / Pressure compensation to be done using AO block or using Modbus or Transducer Block.	---	0 – Temp / Pressure Compensation through Modbus / Transducer Block 1 – Temp / Pressure through AO Block

Table F-23: Transducer block 1 pressure compensation variables -- definitions, defaults, and range of values (continued)

Index	Parameter mnemonic pressure compensation variables	Definition	Default value	Enumerated list of values /range
122	SNS_MflowBaseUnit	Base mass unit for special mass unit	Unit_gm = 60	UNIT_gm = 60 UNIT_kg = 61 UNIT_MetTon = 62 UNIT_lb = 63 UNIT_ShTon = 64 UNIT_LTon = 65
123	SNS_MflowBaseTime	Base time unit for special mass unit	Unit_sec = 51	UNIT_min = 50 UNIT_sec = 51 UNIT_hr = 52 UNIT_day = 53
124	SNS_VflowBaseUnit	Base volume unit for special volume unit	Unit_liter = 41	UNIT_gal = 40 UNIT_liter = 41 UNIT_ImpGal = 42 UNIT_CuMtr = 43 UNIT_bbl = 46 UNIT_CuFt = 112 UNIT_beer_bbl = 170
125	SNS_VflowBaseTime	Base time unit for special volume unit	Unit_sec = 51	UNIT_min = 50 UNIT_sec = 51 UNIT_hr = 52 UNIT_day = 53

Table F-23: Transducer block 1 pressure compensation variables -- definitions, defaults, and range of values (continued)

Index	Parameter mnemonic pressure compensation variables	Definition	Default value	Enumerated list of values /range
126	SNS_GSVflow BaseUnit	Base gas standard volume unit	UNIT_Std CuFt = 168	UNIT_StdLiter = 171 UNIT_NormLiter = 167 UNIT_StdCuMtr = 172 UNIT_NormCuMtr = 166 UNIT_StdCuFt = 168
127	SNS_GSVflow BaseTime	Base time unit for special gas standard volume unit	Unit_sec = 51	UNIT_min = 50 UNIT_sec = 51 UNIT_hr = 52 UNIT_day = 53
128	SYS_MasterReset	Master reset	false	0x00 = None 0x01 = Master reset
129	EMPTY			

Table F-24: Transducer block 1 pressure compensation variables -- size, access, and Modbus register columns

Index	Parameter mnemonic pressure compensation variables	Data Type /Structure	Size	Store/ rate (hz)	Msg type	Access	Modbus register / coil
112	SNS_Enable PresComp (DD Name: Pressure Compensation Enable /Disable)	Unsigned8	1	D	ENUM	R/W	Coil-0082
113	SNS_External PresInput (DD Name : External Pressure calibration input)	101	5	D	RECORD	R/W	R-0451-452
114	SNS_Pressure (The data base item is the same as SNS_ExternalPres Inputparameter) (DD Name : External Read Pressure)	101	5	D	RECORD	R	R-0451-452
115	SNS_PressureUnits (DD Name : Pressure Units)	Unsigned16	2	S	ENUM	R/W	R-0044
116	SNS_FlowPresComp (DD Name: Flow Factor)	Float	4	N-CP	VARIABLE	R/W	R-267-268

Table F-24: Transducer block 1 pressure compensation variables -- size, access, and Modbus register columns (continued)

Index	Parameter mnemonic pressure compensation variables	Data Type /Structure	Size	Store/ rate (hz)	Msg type	Access	Modbus register / coil
117	SNS_DensPresComp (DD Name: Density factor)	Float	4	N-CP	VARIABLE	R/W	R-269-270
118	SNS_FlowCalPres (DD Name: Cal Pressure)	Float	4	N-CP	VARIABLE	R/W	R-271-272
119	SNS_FlowZeroRestoreFactory (DD Name: Restore Factory Zero)	Unsigned8	1	D	METHOD	R/W	Coil-0243
120	DB_SNS_AutoZeroFactory	Float	4	N	VARIABLE	R	R-2673
121	AO_BLK_COMP (DD: Name: AO Compensation)	U8	1	D	VARIABLE	R/W	R-2276
122	SNS_MflowBaseUnit	Unsigned8	1	N	ENUM	R/W	R-132
123	SNS_MflowBaseTime	Unsigned8	1	N	ENUM	R/W	R-133
124	SNS_VflowBaseUnit	Unsigned8	1	N	ENUM	R/W	R-134
125	SNS_VflowBaseTime	Unsigned8	1	N	ENUM	R/W	R-135
126	SNS_GSVflowBaseUnit	Unsigned8	1	N	ENUM	R/W	R2603
127	SNS_GSVflowBaseTime	Unsigned8	1	N	ENUM	R/W	R-2604
128	SYS_MasterReset	Unsigned8	1	D	METHOD	R/W	Coil- 42
129	EMPTY						

F.2.3 Transducer block 1: diagnostic block

The following tables show the parameters for transducer block 1, the diagnostic block.

Diagnostic block slug flow parameters (130-132)

The first table focuses on definitions, default values, and the enumerated list of values allowed for each parameter, while [Table F-26](#) provides the Modbus register column and other relevant values.

Table F-25: Diagnostic block slug flow setup parameters -- definitions, defaults, and range of values

Index	Parameter mnemonic slug flow setup parameters	Definition	Default value	Enumerated list of values /range
130	SNS_SlugDuration (DD Name: Slug Duration)	Slug duration (seconds)	1.0	0 to 60
131	SNS_SlugLo (DD Name : Slug Low Limit)	Low Density limit (g/cc).	0.0	Density limits
132	SNS_SlugHi (DD Name : Slug High Limit)	High Density limit (g/cc)	5.0	Density limits

Table F-26: Diagnostic block slug flow setup parameters -- size, access, and Modbus register columns

Index	Parameter mnemonic slug flow setup parameters	Message type	Data type/ structure	Size	Store/ rate (hz)	Access	Modbus register / coil
130	SNS_SlugDuration (DD Name: Slug Duration)	VARIABLE	Float	4	N-CP	R/W	R-0141-142

Table F-26: Diagnostic block slug flow setup parameters -- size, access, and Modbus register columns (continued)

Index	Parameter mnemonic slug flow setup parameters	Message type	Data type/ structure	Size	Store/ rate (hz)	Access	Modbus register / coil
131	SNS_SlugLo (DD Name : Slug Low Limit)	VARIABLE	Float	4	N-CP	R/W	R-201-202
132	SNS_SlugHi (DD Name : Slug High Limit)	VARIABLE	Float	4	N-CP	R/W	R-199-200

Diagnostic block discrete event variables (133-138)

The first table focuses on definitions, default values, and the enumerated list of values allowed for each parameter, while [Table F-28](#) provides the Modbus register column and other relevant values.

Table F-27: Diagnostic block discrete event variables -- definitions, defaults, and range of values

Index	Parameter mnemonic discrete event variables	Definition	Default value	Enumerated list of values /range
133	DB_SNS_ MflowFactor	Special mass unit conversion factor	1.0	R/W
134	DB_SNS _VflowFactor	Special volume unit conversion factor	1.0	R/W
135	DB_SNS_GSV flowFactor	Special gas standard volume unit conversion factor	1.0	R/W
136	EMPTY			
137	EMPTY			
138	EMPTY			

Table F-28: Diagnostic block discrete event variables -- size, access, and Modbus register columns

Index	Parameter mnemonic discrete event variables	Message type	Data type/ structure	Size	Store/ rate (hz)	Access	Modbus register / coil
133	DB_SNS _MflowFactor	VARIABLE	Float	4	N	R/W	R-237-238
134	DB_SNS _VflowFactor	VARIABLE	Float	4	N	R/W	R-239-240
135	DB_SNS _GSVflowFactor	VARIABLE	Float	4	N	R/W	R-2605-2606
136	EMPTY						
137	EMPTY						
138	EMPTY						

Diagnostic block alarm status variables (139-159)

The first table focuses on definitions, default values, and the enumerated list of values allowed for each parameter, while [Table F-30](#) provides the Modbus register column and other relevant values.

Table F-29: Diagnostic block alarm status variables -- definitions, defaults, and range of values

Index	Parameter mnemonic alarm status variables	Definition	Default value	Enumerated list of values / range
139	PA_StatusWords1 (DD Name: Alarm One Status)	Status Word 1	-	0x0001 = Core EEPROM Checksum Error 0x0002 = Core RAM Test Error 0x0004 = Not Used 0x0008 = Sensor Failure 0x0010 = Temp OOR 0x0020 = Cal Failed 0x0040 = Other Failure 0x0080 = Xmitter Init 0x0100 = Not Used 0x0200 = Not Used 0x0400 = Simulation Mode Active (A132) 0x0800 = Not Used 0x1000 = Not Used 0x2000 = Not Used 0x4000 = Not Used 0x8000 = Fault

Table F-29: Diagnostic block alarm status variables -- definitions, defaults, and range of values (continued)

Index	Parameter mnemonic alarm status variables	Definition	Default value	Enumerated list of values / range
140	PA_StatusWords2 (DD Name: Alarm Two Status)	Status Word 2	-	0x0001 = Not Used 0x0002 = Not Used 0x0004 = Not Used 0x0008 = Not Used 0x0010 = Density OOR 0x0020 = Drive OOR 0x0040 = Not used 0x0080 = Not Used 0x0100 = NV err (CP) 0x0200 = RAM err (CP) 0x0400 = Sensor Failure 0x0800 = Temp OOR 0x1000 = Input OOR 0x2000 = Not Used 0x4000 = Xmitter not Char 0x8000 = Not Used

Table F-29: Diagnostic block alarm status variables -- definitions, defaults, and range of values (continued)

Index	Parameter mnemonic alarm status variables	Definition	Default value	Enumerated list of values / range
141	PA_StatusWords3 (DD Name: Alarm Three Status)	Status Word 3	-	0x0001 = Simulation Enabled 0x0002 = Power Reset 0x0004 = Xmitter Init 0x0008 = Sensor/Xmtr Write Failure omm (A28) 0x0010 = Not Used 0x0020 = Not Used 0x0040 = Not Used 0x0080 = Sensor/Xmtr Communication Failure (A26) 0x0100 = Cal Failed 0x0200 = Cal Fail: Low 0x0400 = Cal Fail: High 0x0800 = Cal Fail: Noisy 0x1000 = Xmtr Failed 0x2000 = Data Loss Possible 0x4000 = Cal in Progress 0x8000 = Slug Flow

Table F-29: Diagnostic block alarm status variables -- definitions, defaults, and range of values (continued)

Index	Parameter mnemonic alarm status variables	Definition	Default value	Enumerated list of values / range
142	PA_StatusWords4 (DD Name: Alarm Four Status)	Status Word 4	-	0x0001 = API: Temp OOR 0x0002 = API: Dens OOR 0x0004 = Line RTD OOR 0x0008 = Meter RTD OOR 0x0010 = Reverse Flow 0x0020 = Factory Config. Data Invalid 0x0040 = ED: bad curve 0x0080 = LMV Override Active 0x0100 = ED: Extrap error 0x0200 = Need cal factor 0x0400 = EEPROM Checksum Error 0x0800 = RAM Test Error 0x1000 = Xmitter not Char 0x2000 = Core configuration database corrupt (CP) 0x4000 = Core powerdown totals corrupt 0x8000 = Core program corrupt

Table F-29: Diagnostic block alarm status variables -- definitions, defaults, and range of values (continued)

Index	Parameter mnemonic alarm status variables	Definition	Default value	Enumerated list of values / range
143	PA_StatusWords5 (DD Name: Alarm Five Status)	Status Word 5	-	0x0001 = Core Protected Boot Sector Fault 0x0002 = Not Used 0x0004 = Not Used 0x0008 = Not Used 0x0010 = Not Used 0x0020 = Not Used 0x0040 = D3 in progress 0x0080 = D4 in progress 0x0100 = Not Used 0x0200 = Not Used 0x0400 = Temp slope in progress 0x0800 = Temp offset in progress 0x1000 = FD in progress 0x2000 = D2 in progress 0x4000 = D1 in progress 0x8000 = Zero in progress

Table F-29: Diagnostic block alarm status variables -- definitions, defaults, and range of values (continued)

Index	Parameter mnemonic alarm status variables	Definition	Default value	Enumerated list of values / range
144	PA_StatusWords6 (DD Name: Alarm Six Status)	Status Word 6	-	0x0001 = Not Used 0x0002 = Not Used 0x0004 = Not Used 0x0008 = Not Used 0x0010 = Not Used 0x0020 = Not Used 0x0040 = Not Used 0x0080 = Not Used 0x0100 = Not Used 0x0200 = Not Used 0x0400 = Not Used 0x0800 = Not Used 0x1000 = Not Used 0x2000 = Not Used 0x4000 = Not Used 0x8000 = Incorrect Board Type (A30)

Table F-29: Diagnostic block alarm status variables -- definitions, defaults, and range of values (continued)

Index	Parameter mnemonic alarm status variables	Definition	Default value	Enumerated list of values / range
145	PA_StatusWords7 (DD Name: Alarm Seven Status)	Status Word 7	-	0x0001 = K1/FCF combination Unrecognized. 0x0002 = Warming Up 0x0004 = Low Power (A31) 0x0008 = Tube Not Full (A33) 0x0010 = Meter Verification / Outputs in fault (A32) 0x0020 = Meter Verification / Outputs at last value (A131) 0x0040 = Not Used 0x0080 = NVM Initialized (transmitter) x0100 = Not Used 0x0200 = Not Used 0x0400 = Not Used 0x0800 = Not Used 0x1000 = Not Used 0x2000 = Not Used 0x4000 = Not Used 0x8000 = Meter Verification aborted (A35)

Table F-29: Diagnostic block alarm status variables -- definitions, defaults, and range of values (continued)

Index	Parameter mnemonic alarm status variables	Definition	Default value	Enumerated list of values / range
146	PA_StatusWords8 (DD Name: Alarm Eight Status)	Status Word 8	-	0x0001 = Not used 0x0002 = Not Used 0x0004 = Not Used 0x0008 = Not Used 0x0010 = Not Used 0x0020 = Not Used 0x0040 = Not Used 0x0080 = Not Used 0x0100 = Not Used 0x0200 = Not Used 0x0400 = Not Used 0x0800 = Not Used 0x1000 = Not Used 0x2000 = Not Used 0x4000 = Not Used 0x8000 = Not Used
147	SYS_DigComm FaultAction Code (DD Name Digital Comm Fault Action)	Fault Limit Code	0	0 = Upscale 1 = Downscale 2 = Zero 3 = NAN 4 = Flow goes to zero 5 = None

Table F-29: Diagnostic block alarm status variables -- definitions, defaults, and range of values (continued)

Index	Parameter mnemonic alarm status variables	Definition	Default value	Enumerated list of values / range
148	DB_SYS_Timeout ValueLMV (DD Name : Last Measured Value Timeout)	Last Measure Value Fault Timeout	0	0 to 60

Table F-29: Diagnostic block alarm status variables -- definitions, defaults, and range of values (continued)

Index	Parameter mnemonic alarm status variables	Definition	Default value	Enumerated list of values / range
149	UNI_Alarm_Index (DD Name: Alarm N Index)	Alarm Index	0	0 = Reserved 1 = NVM Failure 2 = RAM error /ROM error 3 = Sensor Fail 4 = Temp. Overrange 5 = Input Overrange 6 = Transmitter not characterized 7 = Reserved 8 = Dens. Overrange 9 = Xmitter Init 10= Cal Failed 11= Cal Fail: Low 12= Cal Fail: High 13= Cal Fail: Noisy 14= Transmitter Fail 15= Reserved 16= Line RTD Over Range 17= Meter RTD Over Range 18= EEPROM Error (Transmitter) 19= RAM Error (Transmitter) 20= Unconfig – K1 21 = Unrecognized / Unentered sensor type

Index	Parameter mnemonic alarm status variables	Definition	Default value	Enumerated list of values / range
				22 = NV Err (CP) 23= NV Err (CP) 24= NV Err (CP) 25= Boot Fail (CP) 26= Sensor/Xmtr Communication Failure (A26) 27= Security Breach 28= Sensor/Xmtr Write Failure (A28) 29= Internal Communication Failure 30= Hardware / Software Incompatible 31 = Low power 32 = Meter Verification Fault Alarm 33 = Tube not full 34-41 = Undefined 42= Drive Overrange 43 = Data Loss Possible 44= Cal in Progress 45= Slug Flow 46= Undefined 47= Power Reset4 48-55= Reserved 56= API: Temp OOL 57= API:Density OOL

Table F-29: Diagnostic block alarm status variables -- definitions, defaults, and range of values (continued)

Index	Parameter mnemonic alarm status variables	Definition	Default value	Enumerated list of values / range
				58-59= Reserved 60= ED: Unable to fit curve data 61= ED: Extrapolation alarm 62-70= Reserved 71 = Meter Verification Info Alarm 72 = Simulation Mode. 73- 139 = Undefined
150	SYS_Alarm Severity (DD Name : Alarm Severity)	Alarm Severity	0	0 = Ignore 1 = Info 2 = Fault
151	SYS_AlarmStatus (DD Name : Alarm Status)	Alarm Status (write 0 to acknowledge alarm) bit #0 = active (0=no, 1=yes) bit #1 = unacknowledged (0=no, 1=yes)	--	Between 0 to 3
152	SYS_AlarmCount (DD Name : Alarm N Count)	Alarm n count(inactive to active transition)	----	N/A
153	SYS_AlarmPosted (DD Name : Alarm N Last Posted)	Alarm Last Posted (seconds since January 1, 1996)	----	N/A

Table F-29: Diagnostic block alarm status variables -- definitions, defaults, and range of values (continued)

Index	Parameter mnemonic alarm status variables	Definition	Default value	Enumerated list of values / range
154	SYS_Alarm Cleared (DD Name : Alarm N Last Cleared)	Alarm Last cleared (seconds since January 1, 1996)	----	N/A
155	SYS_AckAlarm (DD Name : Acknowledge)	Acknowledge alarm (write alarm index to acknowledge the alarm) 1=A1, ..., 39=A39, 40=A100, ..., 70=A130)	----	Enum list is same as Alarm Index – R1237
156	SYS_AckAllAlarms (DD Name : Acknowledge All)	Acknowledge All Alarms	----	0x00 = Not used 0x01 = Acknowledge
157	SYS_Clear AlarmHistory (DD Name: Reset Alarm History)	Reset Alarm History (“On” = reset, “Off” = N/A)	----	0x00 = Not used 0x01 = Reset
158	EMPTY			
159	EMPTY			

Table F-30: Diagnostic block alarm status variables -- size, access, and Modbus register columns

Index	Parameter mnemonic alarm status variables	Message type	Data type/ structure	Size	Store/ rate (hz)	Access	Modbus register / coil
139	PA_StatusWords1 (DD Name: Alarm One Status)	ENUM	BIT _ENUMERATED	2	D/20	R	R-419
140	PA_StatusWords2 (DD Name: Alarm Two Status)	ENUM	BIT _ENUMERATED	2	D/20	R	R-420
141	PA_StatusWords3 (DD Name: Alarm Three Status)	ENUM	BIT _ENUMERATED	2	D/20	R	R-421
142	PA_StatusWords4 (DD Name: Alarm Four Status)	ENUM	BIT _ENUMERATED	2	D/20	R	R-422
143	PA_StatusWords5 (DD Name: Alarm Five Status)	ENUM	BIT _ENUMERATED	2	D/20	R	R-423
144	PA_StatusWords6 (DD Name: Alarm Six Status)	ENUM	BIT _ENUMERATED	2	D/20	R	R-424
145	PA_StatusWords7 (DD Name: Alarm Seven Status)	ENUM	BIT _ENUMERATED	2	D/20	R	R-433

Table F-30: Diagnostic block alarm status variables -- size, access, and Modbus register columns (continued)

Index	Parameter mnemonic alarm status variables	Message type	Data type/ structure	Size	Store/ rate (hz)	Access	Modbus register / coil
146	PA_StatusWords8 (DD Name: Alarm Eight Status)	ENUM	BIT _ENUMERATED	2	D/20	R	R-434
147	SYS_DigComm FaultActionCode (DD Name Digital Comm Fault Action)	ENUM	Unsigned16	2	S	R/W	R-124
148	DB_SYS_ TimeoutValueLMV (DD Name : Last Measured Value Timeout)	VARIABLE	Unsigned16	2	N-CP	R/W	R-314
149	UNI_Alarm_Index (DD Name: Alarm N Index)	ENUM	Unsigned8	1	D	R/W	R-1237
150	SYS_Alarm Severity (DD Name : Alarm Severity)	ENUM	Unsigned8	1	S	R/W	R-1238
151	SYS_AlarmStatus (DD Name : Alarm Status)	Unsigned 8	BIT _ENUMERATED	1	D20	R/W	R-1239

Table F-30: Diagnostic block alarm status variables -- size, access, and Modbus register columns (continued)

Index	Parameter mnemonic alarm status variables	Message type	Data type/ structure	Size	Store/ rate (hz)	Access	Modbus register / coil
152	SYS_AlarmCount (DD Name : Alarm N Count)	VARIABLE	Unsigned16	2	N	R	R-1240
153	SYS_AlarmPosted (DD Name : Alarm N Last Posted)	VARIABLE	Unsigned32	4	N	R	R1241-1242
154	SYS_Alarm Cleared (DD Name : Alarm N Last Cleared)	VARIABLE	Unsigned32	4	N	R	R1243-1244
155	SYS_AckAlarm (DD Name : Acknowledge)	VARIABLE	Unsigned16	2	D	R/W	R-2623
156	SYS_AckAllAlarms (DD Name : Acknowledge All)	METHOD	Unsigned8	1	D	R/W	Coil-0241
157	SYS_Clear AlarmHistory (DD Name: Reset Alarm History)	METHOD	Unsigned8	1	D	R/W	Coil-0053
158	EMPTY						
159	EMPTY						

Diagnostic block diagnostic variables (160-219)

The first table focuses on definitions, default values, and the enumerated list of values allowed for each parameter, while [Table F-32](#) provides the Modbus register column and other relevant values.

Table F-31: Diagnostic block diagnostic variables -- definitions, defaults, and range of values

Index	Parameter mnemonic diagnostic variables	Definition	Default value	Enumerated list of values /range
160	SNS_DriveGain (DD Name: Drive Gain)	Drive Gain	----	
161	SNS_RawTubeFreq (DD Name: Tube Frequency)	Raw Tube Period	0	N/A
162	SNS_LiveZeroFlow (DD Name : Live Zero Flow)	Live Zero (Mass Flow)	0	N/A
163	SNS_LPOamplitude (DD Name : LPO Amplitude)	Left Pickoff Voltage	0	N/A
164	SNS_RPOamplitude (DD Name : RPO Amplitude)	Right Pickoff Voltage	0	N/A
165	SNS_BoardTemp (DD Name : Board Temperature)	Board Temperature (degC)	0	N/A
166	SNS_MaxBoardTemp (DD Name: Maximum electronic temperature)	Maximum electronics temperature	0	N/A

Table F-31: Diagnostic block diagnostic variables -- definitions, defaults, and range of values (continued)

Index	Parameter mnemonic diagnostic variables	Definition	Default value	Enumerated list of values /range
167	SNS_MinBoardTemp (DD Name: Minimum electronic temperature)	Minimum electronics temperature	0	N/A
168	SNS_AveBoardTemp (DD Name: Average board temperature)	Average electronics temperature	0	N/A
169	SNS_MaxSensorTemp (DD Name: Maximum Sensor temperature)	Maximum sensor temperature	0	N/A
170	SNS_MinSensorTemp (DD Name: Minimum Sensor temperature)	Minimum sensor temperature	0	N/A
171	SNS_AveSensorTemp (DD Name: Average Sensor temperature)	Average sensor temperature	0	N/A
172	SNS_WireRTDRes (DD Name: 9 wire cable RTD)	9-wire cable RTD Resistance (ohms)	0	N/A

Table F-31: Diagnostic block diagnostic variables -- definitions, defaults, and range of values (continued)

Index	Parameter mnemonic diagnostic variables	Definition	Default value	Enumerated list of values /range
173	SNS_LineRTDRes (DD Name: Meter RTD Resistance)	Meter RTD Resistance (ohms)	0	N/A
174	SYS_PowerCycleCount (DD Name: Power Cycle Count)	Number of core processor power cycles	0	N/A
175	SYS_PowerOnTimeSec (DD Name: Power On Time)	Power on time(Seconds since last reset)	---	N/A
176	SNS_InputVoltage (DD Name: Input_Voltage)	Input Voltage(Volts)	---	N/A
177	SNS_TargetAmplitude (DD Name: Target Amplitude)	Actual Target Amplitude (mV/Hz) (Pre 700 2.1, Actual & Override)	---	N/A
178	SNS_CaseRTDRes (DD Name: Case RTD Resistance)	Case RTD Resistance (ohms)	---	N/A
179	SYS_RestoreFactoryConfig (DD Name: Restore Factory Configuration)	Restore Factory Configuration ("On"=restore, "Off"=N/A)	---	0x00 = no action 0x01 = Restore

Table F-31: Diagnostic block diagnostic variables -- definitions, defaults, and range of values (continued)

Index	Parameter mnemonic diagnostic variables	Definition	Default value	Enumerated list of values /range
180	SYS_ResetPowerOnTime (DD Name: Reset Power On Time)	Reset power-on time	---	0x00 = no action 0x01 = Reset
181	FRF_EnableFCFValidation (DD Name: FCF Verification)	Enable FCF Verification 0=disable 1=normal enable 2=Factory Verification of Air 3=Factory Verification of Water 4=debug	---	0x0000 = Disable 0x0001 = Normal Enable 0x0002 = Factory Verification of Air 0x0003 = Factory Verification of Water 0x0004 = Debug
182	FRF_FaultAlarm (DD Name: FCF Verification Alarm)	Output state during FCF Verification 0=Last Value 1=Fault	---	N/A
183	DB_FRF_StiffnessLimit (DD Name: Stiffness limit Set point)	Stiffness Limit Set point	0.04	0 < Stiffness limit <= 1
184	FRF_AlgoState (DD Name: Algorithm State)	Algorithm State (1 through 18)	---	N/A

Table F-31: Diagnostic block diagnostic variables -- definitions, defaults, and range of values (continued)

Index	Parameter mnemonic diagnostic variables	Definition	Default value	Enumerated list of values /range
185	FRF_AbortCode (DD Name: Abort Code)	Abort Code	---	0=No error 1=Manual Abort 2=Watchdog Timeout 3=Frequency Drift 4=High Peak Drive Voltage 5=High Drive Current Standard Deviation 6=High Drive Current Mean Value 7=Drive loop reported error 8=High Delta T Standard Deviation 9=High Delta T Value 10=State Running
186	FRF_StateAtAbort (DD Name: State At Abort)	State at Abort	---	N/A
187	DB_FRF_StiffOutLimLpo (DD Name: LPO Stiffness out of limit)	Stiffness out of limits LPO 0=No 1=Yes	---	N/A
188	DB_FRF_StiffOutLimRpo (DD Name: RPO Stiffness out of limit)	Stiffness out of limits RPO 0=No 1=Yes	---	N/A

Table F-31: Diagnostic block diagnostic variables -- definitions, defaults, and range of values (continued)

Index	Parameter mnemonic diagnostic variables	Definition	Default value	Enumerated list of values /range
189	FRF_Progress (DD Name: Progress)	Progress (% Complete)	---	N/A
190	FRF_AbortCodDB_FRF _StiffnessLpo_Mean (DD Name: Stiffness LPO)	Stiffness LPO – current data means	---	N/A
191	DB_FRF_Stiffness Rpo_Mean (DD Name: Stiffness RPO)	Stiffness RPO – current data means	---	N/A
192	DB_FRF_Damping_Mean (DD Name: Mean Damping)	Damping – current data means	---	N/A
193	DB_FRF_MassLpo_Mean (DD Name: Mean Mass LPO)	Mass LPO – current data means	---	N/A
194	DB_FRF_MassRpo_Mean (DD Name: Mean Mass RPO)	Mass RPO – current data means	---	N/A
195	DB_FRF_StiffnessLpo _StdDev (DD Name: Stiffness LPO)	Stiffness LPO – current data std dev	---	N/A
196	DB_FRF_Stiffness Rpo_StdDev (DD Name: Stiffness RPO)	Stiffness RPO – current data std dev	---	N/A

Table F-31: Diagnostic block diagnostic variables -- definitions, defaults, and range of values (continued)

Index	Parameter mnemonic diagnostic variables	Definition	Default value	Enumerated list of values /range
197	DB_FRF_Damping_StdDev (DD Name: Std Deviation Damping)	Damping – current data std dev	---	N/A
198	DB_FRF_MassLpo_StdDev (DD Name: Std Deviation Mass LPO)	Mass LPO – current data std dev	---	N/A
199	DB_FRF_MassRpo_StdDev (DD Name: Std Deviation Mass RPO)	Mass RPO – current data std dev	---	N/A
200	DB_FRF_StiffnessLpo_AirCal (DD Name: Factory Cal Stiffness LPO)	Stiffness LPO – factory cal air means	---	N/A
201	DB_FRF_StiffnessRpo_AirCal (DD Name: Factory Cal Stiffness RPO)	Stiffness RPO – factory cal air means	---	N/A
202	DB_FRF_Damping_AirCal (DD Name: Damping Factory Cal Air)	Damping – factory cal air means	---	N/A
203	DB_FRF_MassLpo_AirCal (DD Name: Mass LPO Air Cal)	Mass LPO – factory cal air means	---	N/A

Table F-31: Diagnostic block diagnostic variables -- definitions, defaults, and range of values (continued)

Index	Parameter mnemonic diagnostic variables	Definition	Default value	Enumerated list of values /range
204	DB_FRF_MassRpo_AirCal (DD Name: Mass RPO Air Cal)	Mass RPO – factory cal air means	---	N/A
205	DB_FRF_Stiffness Lpo_WaterCal (DD Name: Stiffness LPO Water Cal)	Stiffness LPO – cal water means	---	N/A
206	DB_FRF_Stiffness Rpo_WaterCal (DD Name: Stiffness RPO Water Cal)	Stiffness RPO – cal water means	---	N/A
207	DB_FRF_Damping _WaterCal (DD Name: Damping Water Cal)	Damping – factory cal water means	---	N/A
208	DB_FRF_MassLpo _WaterCal (DD Name: Mass LPO Water Cal)	Mass LPO – factory cal water means	---	N/A
209	DB_FRF_MassRpo _WaterCal (DD Name: Mass RPO Water Cal)	Mass RPO – factory cal air means	---	N/A
210	SNS_DriveCurrent (DD Name: Drive Current)	Drive Current (mA)	---	N/A

Table F-31: Diagnostic block diagnostic variables -- definitions, defaults, and range of values (continued)

Index	Parameter mnemonic diagnostic variables	Definition	Default value	Enumerated list of values /range
211	SNS_SensorFailure TimeoutTime (DD Name: Sensor Failure Time Out)	Sensor Failure Time out (1/16sec units)	---	N/A
212	SNS_MassFlowHiLim	Absolute value of the upper range mass flow of the sensor	---	N/A
213	SNS_TempFlowHiLim	Absolute value of the upper range temperature of the sensor	---	N/A
214	SNS_DensityHiLim	Absolute value of the upper range density of the sensor	---	N/A
215	SNS_VolumeFlowHiLim	Absolute value of the upper range volume flow of the sensor	---	N/A
216	SNS_MassFlowLoLim	Absolute value of the lower range mass flow of the sensor	---	N/A
217	SNS_TempFlowLoLim	Absolute value of the lower range temperature of the sensor	---	N/A
218	SNS_DensityLoLim	Absolute value of the lower range density of the sensor	---	N/A
219	SNS_VolumeFlowLoLim	Absolute value of the lower range volume flow of the sensor	---	N/A

Table F-32: Diagnostic block diagnostic variables --- size, access, and Modbus register columns

Index	Parameter mnemonic diagnostic variables	Message type	Data type/ structure	Size	Store/ rate (hz)	Access	Modbus register / coil
160	SNS_DriveGain (DD Name : Drive Gain)	RECORD	101	5	D	R	R-291-292
161	SNS_RawTubeFreq (DD Name: Tube Frequency)	VARIABLE	Float	4	D20	R	R-285-286
162	SNS_LiveZeroFlow (DD Name : Live Zero Flow)	VARIABLE	Float	4	D20	R	R-293-294
163	SNS_LPOamplitude (DD Name : LPO Amplitude)	VARIABLE	Float	4	D20	R	R-287-288
164	SNS_RPOamplitude (DD Name : RPO Amplitude)	VARIABLE	Float	4	D20	R	R-289-290
165	SNS_BoardTemp (DD Name : Board Temperature)	VARIABLE	Float	4	D20	R	R-383-384
166	SNS_Max BoardTemp (DD Name: Maximum electronic temperature)	VARIABLE	Float	4	D20	R	R-463

Table F-32: Diagnostic block diagnostic variables -- size, access, and Modbus register columns (continued)

Index	Parameter mnemonic diagnostic variables	Message type	Data type/ structure	Size	Store/ rate (hz)	Access	Modbus register / coil
167	SNS_Min BoardTemp (DD Name: Minimum electronic temperature)	VARIABLE	Float	4	D20	R	R-465
168	SNS_Ave BoardTemp (DD Name: Average board temperature)	VARIABLE	Float	4	D20	R	R-467
169	SNS_Max SensorTemp (DD Name: Maximum Sensor temperature)	VARIABLE	Float	4	D20	R	R-435-436
170	SNS_MinSensorTemp (DD Name: Minimum Sensor temperature)	VARIABLE	Float	4	D20	R	R-437-438

Table F-32: Diagnostic block diagnostic variables -- size, access, and Modbus register columns (continued)

Index	Parameter mnemonic diagnostic variables	Message type	Data type/ structure	Size	Store/ rate (hz)	Access	Modbus register / coil
171	SNS_Ave SensorTemp (DD Name: Average Sensor temperature)	VARIABLE	Float	4	D20	R	R-439-440
172	SNS_WireRTDRes (DD Name: 9 wire cable RTD)	VARIABLE	Float	4	D20	R	R-469
173	SNS_LineRTDRes (DD Name: Meter RTD Resistance)	VARIABLE	Float	4	D20	R	R-475
174	SYS_Power CycleCount (DD Name: Power Cycle Count)	VARIABLE	Unsigned16	2	D	R	R-497
175	SYS_PowerOn TimeSec (DD Name: Power On Time)	VARIABLE	Unsigned32	4	N	R	R-2625-2626
176	SNS_InputVoltage (DD Name: Input_Voltage)	VARIABLE	Float	4	D	R	R0385-0386

Table F-32: Diagnostic block diagnostic variables -- size, access, and Modbus register columns (continued)

Index	Parameter mnemonic diagnostic variables	Message type	Data type/ structure	Size	Store/ rate (hz)	Access	Modbus register / coil
177	SNS_Target Amplitude (DD Name: Target Amplitude)	VARIABLE	Float	4	D	R	R-395-396
178	SNS_CaseRTDRes (DD Name: Case RTD Resistance)	VARIABLE	Float	4	D	R	R-473-474
179	SYS_Restore FactoryConfig (DD Name: Restore Factory Configuration)	METHOD	Unsigned8	1	D	R/W	Coil-0247
180	SYS_ResetPower OnTime (DD Name: Reset Power On Time)	METHOD	Unsigned8	1	D	R/W	Coil-242
181	FRF_Enable FCFValidation (DD Name: FCF Verification)	ENUM	Unsigned16	2	D	R/W	R-3000
182	FRF_FaultAlarm (DD Name: FCF Verification Alarm)	VARIABLE	Unsigned16	1	D	R/W	R-3093

Table F-32: Diagnostic block diagnostic variables -- size, access, and Modbus register columns (continued)

Index	Parameter mnemonic diagnostic variables	Message type	Data type/ structure	Size	Store/ rate (hz)	Access	Modbus register / coil
183	DB_FRF_StiffnessLimit (DD Name: Stiffness limit Set point)	VARIABLE	Float	4	N-CP	R/W	R-3147
184	FRF_AlgoState (DD Name: Algorithm State)	VARIABLE	Unsigned16	2	D	R	R-3001
185	FRF_AbortCode (DD Name: Abort Code)	ENUM	Unsigned16	2	D	R	R-3002
186	FRF_StateAtAbort (DD Name: State At Abort)	VARIABLE	Unsigned16	2	D	R	R-3003
187	DB_FRF_StiffOutLimLpo (DD Name: LPO Stiffness out of limit)	VARIABLE	Unsigned16	2	D	R	R-3004
188	DB_FRF_StiffOutLimRpo (DD Name: RPO Stiffness out of limit)	VARIABLE	Unsigned16	2	D	R	R-3005
189	FRF_Progress (DD Name: Progress)	VARIABLE	Unsigned16	2	S	R	R-3020

Table F-32: Diagnostic block diagnostic variables -- size, access, and Modbus register columns (continued)

Index	Parameter mnemonic diagnostic variables	Message type	Data type/ structure	Size	Store/ rate (hz)	Access	Modbus register / coil
190	FRF_AbortCodDB _FRF_Stiffness Lpo_Mean (DD Name: Stiffness LPO)	VARIABLE	Float	4	D	R	R-3101, R-3100
191	DB_FRF_Stiffness Rpo_Mean (DD Name: Stiffness RPO)	VARIABLE	Float	4	D	R	R-3103, R-3100
192	DB_FRF _Damping_Mean (DD Name: Mean Damping)	VARIABLE	Float	4	D	R	R-3105, R-3100
193	DB_FRF _MassLpo_Mean (DD Name: Mean Mass LPO)	VARIABLE	Float	4	D	R	R-3107, R-3100
194	DB_FRF _MassRpo_Mean (DD Name: Mean Mass RPO)	VARIABLE	Float	4	D	R	R-3109, R-3100
195	DB_FRF_Stiffness Lpo_StdDev (DD Name: Stiffness LPO)	VARIABLE	Float	4	D	R	R-3101, R-3100
196	DB_FRF_Stiffness Rpo_StdDev (DD Name: Stiffness RPO)	VARIABLE	Float	4	D	R	R-3103, R-3100

Table F-32: Diagnostic block diagnostic variables -- size, access, and Modbus register columns (continued)

Index	Parameter mnemonic diagnostic variables	Message type	Data type/ structure	Size	Store/ rate (hz)	Access	Modbus register / coil
197	DB_FRF_Damping _StdDev (DD Name: Std Deviation Damping)	VARIABLE	Float	4	D	R	R-3105, R-3100
198	DB_FRF_Mass Lpo_StdDev (DD Name: Std Deviation Mass LPO)	VARIABLE	Float	4	D	R	R-3107, R-3100
199	DB_FRF_Mass Rpo_StdDev (DD Name: Std Deviation Mass RPO)	VARIABLE	Float	4	D	R	R-3109, R-3100
200	DB_FRF_Stiffness Lpo_AirCal (DD Name: Factory Cal Stiffness LPO)	VARIABLE	Float	4	D	R	R-3101, R-3100
201	DB_FRF_Stiffness Rpo_AirCal (DD Name: Factory Cal Stiffness RPO)	VARIABLE	Float	4	D	R	R-3103, R-3100
202	DB_FRF _Damping_AirCal (DD Name: Damping Factory Cal Air)	VARIABLE	Float	4	D	R	R-3105, R-3100

Table F-32: Diagnostic block diagnostic variables -- size, access, and Modbus register columns (continued)

Index	Parameter mnemonic diagnostic variables	Message type	Data type/ structure	Size	Store/ rate (hz)	Access	Modbus register / coil
203	DB_FRF _MassLpo_AirCal (DD Name: Mass LPO Air Cal)	VARIABLE	Float	4	D	R	R-3107, R-3100
204	DB_FRF _MassRpo_AirCal (DD Name: Mass RPO Air Cal)	VARIABLE	Float	4	D	R	R-3109, R-3100
205	DB_FRF_Stiffness Lpo_WaterCal (DD Name: Stiffness LPO Water Cal)	VARIABLE	Float	4	D	R	R-3101, R-3100
206	DB_FRF_Stiffness Rpo_WaterCal (DD Name: Stiffness RPO Water Cal)	VARIABLE	Float	4	D	R	R-3103, R-3100
207	DB_FRF_Damping _WaterCal (DD Name: Damping Water Cal)	VARIABLE	Float	4	D	R	R-3105, R-3100

Table F-32: Diagnostic block diagnostic variables -- size, access, and Modbus register columns (continued)

Index	Parameter mnemonic diagnostic variables	Message type	Data type/ structure	Size	Store/ rate (hz)	Access	Modbus register / coil
208	DB_FRF_Mass Lpo_WaterCal (DD Name: Mass LPO Water Cal)	VARIABLE	Float	4	D	R	R-3107, R-3100
209	DB_FRF_Mass Rpo_WaterCal (DD Name: Mass RPO Water Cal)	VARIABLE	Float	4	D	R	R-3109, R-3100
210	SNS_DriveCurrent (DD Name: Drive Current)	VARIABLE	Float	4	D/20	R	R-0401
211	SNS_SensorFailure TimeoutTime (DD Name: Sensor Failure Time Out)	VARIABLE	Unsigned16	2	N-CP	R/W	R-0399
212	SNS_MassFlow HiLim	SIMPLE	Float	4	N-CP	R	R-0165
213	SNS_TempFlow HiLim	SIMPLE	Float	4	N-CP	R	R-0167
214	SNS_DensityHiLim	SIMPLE	Float	4	N-CP	R	R-0169
215	SNS_VolumeFlow HiLim	SIMPLE	Float	4	N-CP	R	R-0171
216	SNS_MassFlow LoLim	SIMPLE	Float	4	N-CP	R	R-0173

Table F-32: Diagnostic block diagnostic variables -- size, access, and Modbus register columns (continued)

Index	Parameter mnemonic diagnostic variables	Message type	Data type/ structure	Size	Store/ rate (hz)	Access	Modbus register / coil
217	SNS_TempFlow LoLim	SIMPLE	Float	4	N-CP	R	R-0175
218	SNS_DensityLoLim	SIMPLE	Float	4	N-CP	R	R-0177
219	SNS_VolumeFlow LoLim	SIMPLE	Float	4	N-CP	R	R-0179

Diagnostic block LDO variables (220-254)

The first table focuses on definitions, default values, and the enumerated list of values allowed for each parameter, while [Table F-34](#) provides the Modbus register column and other relevant values.

Table F-33: Diagnostic block LDO variables -- definitions, defaults, and range of values

Index	Parameter mnemonic LDO variables	Definition	Default value	Enumerated list of values / range
220	UI_EnableLdo TotalizerReset (DD Name: Totalizer Reset)	Enable/Disable LDO Totalizer Reset	0x01	0x00 = disabled 0x01 = enabled
221	UI_EnableLdo TotalizerStartStop (DD Name: Start/ Stop Totals)	Enable/Disable LDO Totalizer Start/Stop option	0x01	0x00 = disabled 0x01 = enabled
222	UI_EnableLdo AutoScrol (DD Name: Auto Scroll)Y	Enable/Disable LDO Auto Scroll Feature	0x00	0x00 = disabled 0x01 = enabled

Table F-33: Diagnostic block LDO variables -- definitions, defaults, and range of values (continued)

Index	Parameter mnemonic LDO variables	Definition	Default value	Enumerated list of values / range
223	UI_EnableSecurity (DD Name: Offline Password)	Enable/Disable LDO Offline Menu Feature	0x01	0x00 = disabled 0x01 = enabled
224	UI_EnableSecurity (DD Name: Offline Password)	Enable/Disable LDO Offline Password	0x00	0x00 = disabled 0x01 = enabled
225	UI_EnableLdo AlarmMenu (DD Name: Alarm Menu)	Enable/Disable LDO Alarm Menu	0x01	0x00 = disabled 0x01 = enabled
226	UI_EnableLdo AckAllAlarms (DD Name: ACK All Alarms)	Enable/Disable LDO Acknowledge All alarms Feature	0x01	0x00 = disabled 0x01 = enabled
227	UI_OfflinePassword (DD Name: Enter Offline Password)	LDO offline password	1234	0 – 9999
228	UI_AutoScrollRate (DD Name: ScrollPeriod)	LDO Scroll rate	10	Between 1 to 30
229	UI_BacklightOn (DD Name: BackLight)	LDO Backlight Control	0x01	0x00 = off 0x01 = on

Table F-33: Diagnostic block LDO variables -- definitions, defaults, and range of values (continued)

Index	Parameter mnemonic LDO variables	Definition	Default value	Enumerated list of values / range
230	UNI_UI_ProcVarIndex (DD Name: Display Variable	Process Variable Code (n = 0...94)	---	0 = Mass Flow Rate 1 = Temperature 2 = Mass Total 3 = Density 4 = Mass Inventory 5 = Line (Gross) Volume Flow Rate 6 = Line (Gross) Volume Total 7 = Line (Gross) Volume Inventory 8-11 = Not used 12 = Status Word 1 13 = Status Word 2 14 = Status Word 3 15 = API: Temp Corrected Density 16 = API: Temp Corrected (Standard) Volume Flow 17 = API: Temp Corrected (Standard) Volume Total 18 = API: Temp Corrected (Standard) Volume Inventory

Index	Parameter mnemonic LDO variables	Definition	Default value	Enumerated list of values / range
				19= API: Batch Weighted Average Density 20= API: Batch Weighted Average Temperature 21= Enhanced Density At Reference 22= Enhanced Density (Fixed SG Units) 23= Enhanced Density: Standard Volume Flow Rate 24= Enhanced Density: Standard Volume Total 25= Enhanced Density: Standard Volume Inventory 26= Enhanced Density: Net Mass Flow Rate 27= Enhanced Density: Net Mass Total 28= Enhanced Density: Net Mass Inventory 29= Enhanced Density: Net Volume Flow Rate 30= Enhanced Density: Net Volume Total 31= Enhanced Density: Net Volume Inventory 32= Enhanced Density: Concentration

Index	Parameter mnemonic LDO variables	Definition	Default value	Enumerated list of values / range
				33= API: CTL 34 = Raw Mass Total, MSD (Double) 35 = Raw Mass Total, LSD (Double) 36 = Raw API: Temp/ Pressure Corrected Volume Total, MSD (Double) 37= Raw Line (Gross) Volume Total, LSD (Double) 38 = Raw API: Temp/ Pressure Corrected Volume Total, MSD (Double) 39 = Raw API: Temp/ Pressure Corrected Volume Total, LSD (Double) 40 = Raw Enhanced Density: Standard Volume Total, MSD (Double) 41 = Raw Enhanced Density: Standard Volume Total, LSD (Double) 42 = Raw Enhanced Density: Net Mass

Index	Parameter mnemonic LDO variables	Definition	Default value	Enumerated list of values / range
				Total, MSD (Double) 43 = Raw Enhanced Density: Net Mass Total, LSD (Double) 44 = Raw Enhanced Density: Net Volume Total MSD (Double) 46=Raw Tube Frequency 47= Drive Gain 48= Case Temperature (T-Series) 49= LPO Amplitude 50= RPO Amplitude 51= Board Temperature 52= Input Voltage 53= Externally read Pressure 54= Mechanical Zero 55= Externally read Temperature 56= Enhanced Density: Density (Fixed Baume Units)/ Enhanced Density: Density (Special Density Units) 57 = Discrete Event 58 = Discrete Event 2 59 = Discrete Event 3

Index	Parameter mnemonic LDO variables	Definition	Default value	Enumerated list of values / range
				60 = Discrete Event 4 61 = Discrete Event 5 62= Gas Standard Volume Flow Rate 63= Gas Standard Volume Total 64= Gas Standard Volume Inventory 65 = Status word 4 66 = Raw Gas Standard Volume Total, MSD (Double) 67 = Raw Gas Standard Volume Total, LSD (Double) 68 = Not used 69= Live Zero 70-101= Not used 102 = Forward/Reverse Indication 103 = Calibration in Progress 104 = Fault Condition Indication 105-112 = Not used 113-156 = MF

Table F-33: Diagnostic block LDO variables -- definitions, defaults, and range of values (continued)

Index	Parameter mnemonic LDO variables	Definition	Default value	Enumerated list of values / range
				157-255 = Not Used
231	UI_NumDecimals (DD Name: No. of Decimals)	For Totals, the number of digits to the right of the decimal point to display on LDO	-	0 to 5

Table F-33: Diagnostic block LDO variables -- definitions, defaults, and range of values (continued)

Index	Parameter mnemonic LDO variables	Definition	Default value	Enumerated list of values / range
232	UI_ProcessVariables (LDO_VAR_1_CODE) (DD Name: Display Variable 1)	Display the Variable #1 associated with the code on the LDO	0	0 = Mass Flow Rate 1 = Temperature 2 = Mass Total 3 = Density 4 = Mass Inventory 5 = Volume Flow Rate 6 = Volume Total 7 = Volume Inventory 8 – 11 = Not used 12 = Status Word 1 13 = Status Word 2 14 = Status Word 3 15 = API: Corr Density 16 = API: Corr Vol Flow 17 = API: Corr Vol Total 18 = API: Corr Vol Inv 19 = API: Avg Density 20 = API: Avg Temp 21 = ED: Density At Ref 22 = ED: Density (SGU) 23 = ED: Std Vol Flow Rate 24 = ED: Std Vol Total 25 = ED: Std Vol Inventory 26 = ED: Net Mass Flow 27 = ED: Net Mass Total

Index	Parameter mnemonic LDO variables	Definition	Default value	Enumerated list of values / range
				28 = ED: Net Mass Inv 29 = ED: Net Vol Flow Rate 30 = ED: Net Vol Total 31 = ED: Net Vol Inventory 32 = ED: Concentration 33 = API: CTL 34 = Raw Mass Total, MSD (Double) 35 = Raw Mass Total, LSD (Double) 36 = Raw API: Temp/ Pressure Corrected Volume Total MSD, (Double) 37 = Raw Line (Gross) VolumeTotal LSD, (Double) 38 = Raw API: Temp/ Pressure Corrected Volume Total MSD, (Double) 39 = Raw API: Temp/ Pressure Corrected Volume Total LSD, (Double) 40 = Raw Enhanced Density: Standard Volume

Index	Parameter mnemonic LDO variables	Definition	Default value	Enumerated list of values / range
				Total, MSD (Double) 41 = Raw Enhanced Density: Standard Volume Total, LSD (Double) 42 = Raw Enhanced Density: Net Mass Total, MSD (Double) 43 = Raw Enhanced Density: Net Mass Total, LSD (Double) 44 = Raw Enhanced Density: Net Volume Total, MSD (Double) 45 = Raw Enhanced Density: Net Volume Total, LSD (Double) 46 = Raw Tube Frequency 47 = Drive Gain 48 = Case Temperature 49 = LPO Amplitude 50 = RPO Amplitude 51 = Board Temperature 52 = Input Voltage 53 = Ext. Input Pressure 54 = Mechanical Zero 55 = Ext. Input Temp 56 = ED: Density (Baume)

Index	Parameter mnemonic LDO variables	Definition	Default value	Enumerated list of values / range
				57-61 = Not used 62 = Gas Std Vol Flow 63 = Gas Std Vol Total 64 = Gat Std Vol Inventory 65-68 = Not used 69 = Live Zero 70 – 255 = Not used

Table F-33: Diagnostic block LDO variables -- definitions, defaults, and range of values (continued)

Index	Parameter mnemonic LDO variables	Definition	Default value	Enumerated list of values / range
233	UI_ProcessVariables (LDO_VAR_2_CODE) (DD Name: Display Variable 2)	Display the Variable #2 associated with the code on the LDO	2	0 = Mass Flow Rate 1 = Temperature 2 = Mass Total 3 = Density 4 = Mass Inventory 5 = Volume Flow Rate 6 = Volume Total 7 = Volume Inventory 8 – 11 = Not used 12 = Status Word 1 13 = Status Word 2 14 = Status Word 3 15 = API: Corr Density 16 = API: Corr Vol Flow 17 = API: Corr Vol Total 18 = API: Corr Vol Inv 19 = API: Avg Density 20 = API: Avg Temp 21 = ED: Density At Ref 22 = ED: Density (SGU) 23 = ED: Std Vol Flow Rate 24 = ED: Std Vol Total 25 = ED: Std Vol Inventory 26 = ED: Net Mass Flow 27 = ED: Net Mass Total

Index	Parameter mnemonic LDO variables	Definition	Default value	Enumerated list of values / range
				28 = ED: Net Mass Inv 29 = ED: Net Vol Flow Rate 30 = ED: Net Vol Total 31 = ED: Net Vol Inventory 32 = ED: Concentration 33 = API: CTL 34 = Raw Mass Total, MSD (Double) 35 = Raw Mass Total, LSD (Double) 36 = Raw API: Temp/ Pressure Corrected Volume Total, MSD (Double) 37 = Raw Line (Gross) Volume Total, LSD (Double) 38 = Raw API: Temp/ Pressure Corrected Volume Total, MSD (Double) 39 = Raw API: Temp/ Pressure Corrected Volume Total, LSD (Double) 40 = Raw Enhanced Density: Standard Volume Total, MSD (Double)

Index	Parameter mnemonic LDO variables	Definition	Default value	Enumerated list of values / range
				41 = Raw Enhanced Density: Standard Volume Total, LSD (Double) 42 = Raw Enhanced Density: Net Mass Total, MSD (Double) 43 = Raw Enhanced Density: Net Mass Total, LSD (Double) 44 = Raw Enhanced Density: Net Volume Total, MSD (Double) 45 = Raw Enhanced Density: Net Volume Total, LSD (Double) 46 = Raw Tube Frequency 47 = Drive Gain 48 = Case Temperature 49 = LPO Amplitude 50 = RPO Amplitude 51 = Board Temperature 52 = Input Voltage 53 = Ext. Input Pressure 54 = Mechanical Xero 55 = Ext. Input Temp 56 = ED: Density (Baume) 57 = Discrete Event 1

Index	Parameter mnemonic LDO variables	Definition	Default value	Enumerated list of values / range
				58 = Discrete Event 2 59 = Discrete Event 3 60 = Discrete Event 4 61 = Discrete Event 5 62 = Gas Std Vol Flow 63 = Gas Std Vol Total 64 = Gas Std Vol Inventory 65 = Status word 4 66 = Raw Gas Standard Volume Total, MSD (Double) 67 = Raw Gas Standard Volume Total, LSD (Double) 68 = Not used 69 = Live Zero 70-101 = Not used 102 = Forward/Reverse Indication 103 Calibration in Progress 104 = Fault Condition Indication 105-112 = Not used 113-156 = MF 157-255 = Not used

Table F-33: Diagnostic block LDO variables -- definitions, defaults, and range of values (continued)

Index	Parameter mnemonic LDO variables	Definition	Default value	Enumerated list of values / range
234	UI_ProcessVariables (LDO_VAR_3_CODE) (DD Name: Display Variable 3)	Display the Variable #3 associated with the code on the LDO	5	Same as LDO_VAR_2_CODE
235	UI_ProcessVariables (LDO_VAR_4_CODE) (DD Name: Display Variable 4)	Display the Variable #4 associated with the code on the LDO	6	Same as LDO_VAR_2_CODE
236	UI_ProcessVariables (LDO_VAR_5_CODE) (DD Name: Display Variable 5)	Display the Variable #5 associated with the code on the LDO	3	Same as LDO_VAR_1_CODE
237	UI_ProcessVariables (LDO_VAR_6_CODE) (DD Name: Display Variable 6)	Display the Variable #6 associated with the code on the LDO	1	Same as LDO_VAR_1_CODE
238	UI_ProcessVariables (LDO_VAR_7_CODE) (DD Name: Display Variable 7)	Display the Variable #7 associated with the code on the LDO	251	Same as LDO_VAR_1_CODE
239	UI_ProcessVariables (LDO_VAR_8_CODE) (DD Name: Display Variable 8)	Display the Variable #8 associated with the code on the LDO	251	Same as LDO_VAR_1_CODE

Table F-33: Diagnostic block LDO variables -- definitions, defaults, and range of values (continued)

Index	Parameter mnemonic LDO variables	Definition	Default value	Enumerated list of values / range
240	UI_ProcessVariables (LDO_VAR_9_CODE) (DD Name: Display Variable 9)	Display the Variable #9 associated with the code on the LDO	251	Same as LDO_VAR_1_CODE
241	UI_ProcessVariables (LDO_VAR_10_CODE) (DD Name: Display Variable 10)	Display the Variable #10 associated with the code on the LDO	251	Same as LDO_VAR_1_CODE
242	UI_ProcessVariables (LDO_VAR_11_CODE) (DD Name: Display Variable 11)	Display the Variable #11 associated with the code on the LDO	251	Same as LDO_VAR_1_CODE
243	UI_ProcessVariables (LDO_VAR_12_CODE) (DD Name: Display Variable 12)	Display the Variable #12 associated with the code on the LDO	251	Same as LDO_VAR_1_CODE
244	UI_ProcessVariables (LDO_VAR_13_CODE) (DD Name: Display Variable 13)	Display the Variable #13 associated with the code on the LDO	251	Same as LDO_VAR_1_CODE
245	UI_ProcessVariables (LDO_VAR_14_CODE) (DD Name: Display Variable 14)	Display the Variable #14 associated with the code on the LDO	251	Same as LDO_VAR_1_CODE

Table F-33: Diagnostic block LDO variables -- definitions, defaults, and range of values (continued)

Index	Parameter mnemonic LDO variables	Definition	Default value	Enumerated list of values / range
246	UI_ProcessVariables (LDO_VAR_15_CODE) (DD Name: Display Variable 15)	Display the Variable #15 associated with the code on the LDO	251	Same as LDO_VAR_12_CODE
247	UI_Update Period msec (DD: Name: Update Period)	Display update period in milliseconds.	200ms	Between 100 to 10,000
248	EMPTY		251	
249	UI_Language (DD: Name: Language)	Display language selection	English	0 = English 1 = German 2 = French 3 = Not used 4 = Spanish
250	UI_FixStatusLED (DD: Name: Status LED)	Simulate the Status LED	0x0000	0 = unfix 1 = green 2 = red 3 = yellow 4 = off (add 4 to flash)
251	EMPTY			
252	EMPTY			
253	EMPTY			
254	Transducer Block1 VIEW1			

Table F-34: Diagnostic block LDO variables --- size, access, and Modbus register columns

Index	Parameter mnemonic LDO variables	Message type	Data type/ structure	Size	Store/ rate (hz)	Access	Modbus register / coil
220	UI_EnableLdo TotalizerReset (DD Name: Totalizer Reset)	ENUM	Unsigned8	1	S	R/W	Coil-0094
221	UI_EnableLdo TotalizerStartStop (DD Name: Start/ Stop Totals)	ENUM	Unsigned8	1	S	R/W	Coil-0091
222	UI_EnableLdo AutoScrol (DD Name: Auto Scroll)	ENUM	Unsigned8	1	S	R/W	Coil-0095
223	UI_EnableLdo OfflineMenu (DD Name: Offline Menu)	ENUM	Unsigned8	1	S	R/W	C-0096
224	UI_EnableSecurity (DD Name: Offline Password)	ENUM	Unsigned8	1	S	R/W	C-0097
225	UI_EnableLdo AlarmMenu (DD Name: Alarm Menu)	ENUM	Unsigned8	1	S	R/W	C-0098
226	UI_Enabeldo AckAllAlarms (DD Name: Ack All Alarms)	ENUM	Unsigned8	1	S	R/W	C-0099

Table F-34: Diagnostic block LDO variables -- size, access, and Modbus register columns (continued)

Index	Parameter mnemonic LDO variables	Message type	Data type/ structure	Size	Store/ rate (hz)	Access	Modbus register / coil
227	UI_OfflinePassword (DD Name: Enter Offline Password)	VARIABLE	Unsigned16	2	S	R/W	R-1115
228	UI_AutoScrollRate (DD Name: ScrollPeriod)	VARIABLE	Unsigned16	2	S	R/W	R-1116
229	UI_BacklightOn (DD Name: BackLight)	ENUM	Unsigned8	1	S	R/W	Coil-0050
230	UNI_UI _ProcVarIndex (DD Name: Display Variable)	ENUM	Unsigned8	1	D	R/W	R- 1367
231	UI_NumDecimals (DD Name: No. of Decimals)	VARIABLE	Unsigned8	1	S	R/W	R- 1368
232	UI_ProcessVariables (LDO_VAR_1_CODE) (DD Name: Display Variable 1)	ENUM	Unsigned16	2	S	R/W	R- 1117
233	UI_ProcessVariables (LDO_VAR_2_CODE) (DD Name: Display Variable 2)	ENUM	Unsigned16	2	S	R/W	R- 1118

Table F-34: Diagnostic block LDO variables --- size, access, and Modbus register columns (continued)

Index	Parameter mnemonic LDO variables	Message type	Data type/ structure	Size	Store/ rate (hz)	Access	Modbus register / coil
234	UI_ProcessVariables (LDO_VAR_3_CODE) (DD Name: Display Variable 3)	ENUM	Unsigned16	2	S	R/W	R- 1119
235	UI_ProcessVariables (LDO_VAR_4_CODE) (DD Name: Display Variable 4)	ENUM	Unsigned16	2	S	R/W	R- 1120
236	UI_ProcessVariables (LDO_VAR_5_CODE) (DD Name: Display Variable 5)	ENUM	Unsigned16	2	S	R/W	R- 1121
237	UI_ProcessVariables (LDO_VAR_6_CODE) (DD Name: Display Variable 6)	ENUM	Unsigned16	2	S	R/W	R-1122
238	UI_ProcessVariables (LDO_VAR_7_CODE) (DD Name: Display Variable 7)	ENUM	Unsigned16	2	S	R/W	R-1123
239	UI_ProcessVariables (LDO_VAR_8_CODE) (DD Name: Display Variable 8)	ENUM	Unsigned16	2	S	R/W	R-1124

Table F-34: Diagnostic block LDO variables --- size, access, and Modbus register columns (continued)

Index	Parameter mnemonic LDO variables	Message type	Data type/ structure	Size	Store/ rate (hz)	Access	Modbus register / coil
240	UI_ProcessVariables (LDO_VAR_9_CODE) (DD Name: Display Variable 9)	ENUM	Unsigned16	2	S	R/W	R-1125
241	UI_ProcessVariables (LDO_VAR_10_CODE) (DD Name: Display Variable 10)	ENUM	Unsigned16	2	S	R/W	R-1126
242	UI_ProcessVariables (LDO_VAR_11_CODE) (DD Name: Display Variable 11)	ENUM	Unsigned16	2	S	R/W	R-1127
243	UI_ProcessVariables (LDO_VAR_12_CODE) (DD Name: Display Variable 12)	ENUM	Unsigned16	2	S	R/W	R-1128
244	UI_ProcessVariables (LDO_VAR_13_CODE) (DD Name: Display Variable 13)	ENUM	Unsigned16	2	S	R/W	R-1129

Table F-34: Diagnostic block LDO variables --- size, access, and Modbus register columns (continued)

Index	Parameter mnemonic LDO variables	Message type	Data type/ structure	Size	Store/ rate (hz)	Access	Modbus register / coil
245	UI_ProcessVariables (LDO_VAR_14_CODE) (DD Name: Display Variable 14)	ENUM	Unsigned16	2	S	R/W	R-1130
246	UI_ProcessVariables (LDO_VAR_15_CODE) (DD Name: Display Variable 15)	ENUM	Unsigned16	2	S	R/W	R-1131
247	UI_UpdatePeriod msec DD Name UPDATE PERIOD:	VARIABLE	Unsigned16	2	S	R/W	R-2621
248	EMPTY						
249	UI_Language DD Name: LANGUAGE	ENUM	Unsigned16	2	S	R/W	R-1359
250	STATUS_LED_TEST DD Name: STATUS LED	ENUM	Unsigned16	2	D	R/W	R-5006
251	EMPTY						
252	EMPTY						
253	EMPTY						
254	Transducer Block1 VIEW1						

F.2.4 Transducer block 1 object and views

Transducer block 1 object

The following table shows the transducer block 1 object.

- Transducer block 1 object: [Table F-35](#)
- Transducer block view #1: [Table F-36](#)
- Transducer block view #2: [Table F-37](#)

Table F-35: Transducer block 1 object

Slot/ Index	Element name	Data type	Size in bytes	Value
Slot 11/ Index 0	Reserved	Unsigned 8	1	250 (default)
	Block_Object	Unsigned 8	1	03
	Parent_Class	Unsigned 8	1	03
	Class	Unsigned 8	1	03
	DD_Reference	Unsigned 32	4	00 ,00, 00, 00 (reserved)
	DD_Revision	Unsigned 16	2	00 ,00 (reserved)
	Profile	Octet string	2	64 02 (compact class B)
	Profile_Revision	Unsigned 16	2	03 01 (3.01)
	Execution_Time	Unsigned 8	1	00 (for future use)
	Number-Of_Parameters	Unsigned 16	2	00 254 (Maximum number of Transducer Block 1 Parameters)
	Address_of_View_1	Unsigned 16	2	11 254 (slot, index)
	Number_of_Views	Unsigned 8	1	01 (1 view)

Transducer block 1 (measurement, calibration, and diagnosis) views

The following tables show the views for transducer block 1.

Table F-36: Transducer block view -- standard PA parameters

OD index	Parameter mnemonic -- standard PA parameters	View 1	View 2	View 3	View 4
0	BLOCK_OBJECT				
1	ST_REV	2			
2	TAG_DESC				
3	STRATEGY				
4	ALERT_KEY				

Table F-36: Transducer block view -- standard PA parameters (continued)

OD index	Parameter mnemonic -- standard PA parameters	View 1	View 2	View 3	View 4
5	TARGET_MODE				
6	MODE_BLK	3			
7	ALARM_SUM	8			
	Overall sum of bytes in View Object	13			

Table F-37: Transducer block 1 view -- standard flow transducer block parameters

OD index	Parameter mnemonic -- standard parameters	View 1	View 2	View 3	View 4
21	MASS FLOW	5			
25	DENSITY	5			
29	TEMPERATURE	5			
254	Overall sum of bytes in View Object (+ 13 Standard parameters bytes)	15 + 13			

F.2.5 Transducer block 2 (device information, API, CM) parameters

The following tables show the parameters for transducer block 2.

Transducer block 2 standard PA parameters (0-7)

The first table focuses on definitions, default values, and the enumerated list of values allowed for each parameter, while [Table F-39](#) provides the Modbus register column and other relevant values.

Table F-38: Transducer block 2 standard PA parameters -- definitions, defaults, and range of values

Index	Parameter mnemonic standard PA parameters	Definition	Default value	Enumerated list of values /range
0	BLOCK_OBJECT	This object contains the characteristics of the block.	----	NA

Table F-38: Transducer block 2 standard PA parameters -- definitions, defaults, and range of values (continued)

Index	Parameter mnemonic standard PA parameters	Definition	Default value	Enumerated list of values /range
1	ST_REV	A block has static block parameters that are not changed by the process. Values are assigned to this parameter during the configuration of optimization. The value of ST_REV increases by 1 after every change of a static block parameter.	0	NA
2	TAG_DESC	Every block can be assigned a textual TAG description. The TAG_DESC must be unambiguous and unique in the field bus system.	''	NA
3	STRATEGY	Grouping of function block. The STRATEGY field can be used to group blocks.	0	NA
4	ALERT_KEY	This parameter contains the identification number of the plant unit.	0	NA
5	TARGET_MODE	This parameter contains desired mode normally set by a control application of an operator. The modes are valid alternatively only; for example, only one mode can be set at one time. A write access to this parameter with more than one mode is out of the range of the parameter and has to be rejected.	AUTO (*0x08)	AUTO (0x8)
6	MODE_BLK	This parameter contains the current mode and the permitted and normal mode of the block.	----	NA
7	ALARM_SUM	This parameter contains the current states of the block alarms.	0,0,0,0	NA

Table F-39: Transducer block 2 standard PA parameters -- size, access, and Modbus register columns

Index	Parameter mnemonic standard PA parameters	Message type	Data type/ structure	Size	Store/ rate (hz)	Access	Modbus register / coil
0	BLOCK_OBJECT	RECORD	DS-32	20	S	R	NA
1	ST_REV	SIMPLE	Unsigned16	2	N	R	NA
2	TAG_DESC	SIMPLE	OCTET string	32	S	R/W	NA
3	STRATEGY	SIMPLE	Unsigned16	2	S	R/W	NA
4	ALERT_KEY	SIMPLE	Unsigned8	1	S	R/W	NA
5	TARGET_MODE	SIMPLE	Unsigned8	1	S	R/W	NA
6	MODE_BLK	RECORD	DS-37	3	D	R	NA
7	ALARM_SUM	RECORD	DS-42	8	D	R	NA

Transducer block 2 device information block: transmitter data (8-9)

The first table focuses on definitions, default values, and the enumerated list of values allowed for each parameter, while [Table F-41](#) provides the Modbus register column and other relevant values.

Table F-40: Transducer block 2 device information block: transmitter data -- definitions, defaults, and range of values

Index	Parameter device information block transmitter data	Definition	Default value	Enumerated list of values /range
8	SYS_FeatureKey (DD Name: Enabled Features)	Enabled Features	-	0x0000 = standard 0x0800 = Meter Verification 0x0008 = Enh. Density 0x0010 = API
9	SYS_CEQ_Number (DD Name: CP ETO)	Model 2700 Transmitter CEQ Number	SW Rev	NA

Table F-41: Transducer block 2 device information block: transmitter data -- size, access, and Modbus register columns

Index	Parameter device information block transmitter data	Message type	Data type/ structure	Size	Store/ rate (hz)	Access	Modbus register / coil
8	SYS_FeatureKey (DD Name: Enabled Features)	String	BIT _ENUMERATE D	2	N	R	R-5000
9	SYS_CEQ_Number (DD Name: CP ETO)	VARIABLE	Unsigned16	2	N	R/W	R-5005

Transducer block 2 device information block: sensor data (10-28)

The first table focuses on definitions, default values, and the enumerated list of values allowed for each parameter, while [Table F-43](#) provides the Modbus register column and other relevant values.

Table F-42: Transducer block 2 device information block: sensor data -- definitions, defaults, and range of values

Index	Parameter device information block sensor data	Definition	Default value	Enumerated list of values /range
10	SNS_Sensor SerialNum (DD Name : Sensor Serial Number)	Sensor serial number	0	≥=0 ≤=16777215.0f
11	SNS_SensorType (DD Name: Sensor Model Number)	Sensor type (i.e. F200, CMF025)	""	NA
12	SNS_Sensor TypeCode (DD Name: Sensor Type Code)	Sensor type code	0	0 = Curve Tube 1 = Straight Tube

Table F-42: Transducer block 2 device information block: sensor data -- definitions, defaults, and range of values (continued)

Index	Parameter device information block sensor data	Definition	Default value	Enumerated list of values /range
13	NS_SensorMaterial (DD Name : Sensor Material)	Sensor Material	0	0 = None 3 = Hastelloy C-22 4 = Monel 5 = Tantalum 6 = Titanium 19 = 316L stainless steel 23 = Inconel 252 = Unknown 253 = Special
14	SNS_LinerMaterial (DD Name : Sensor Liner)	Liner Material	0	0 = None 10 = PTFE (2larms) 11 = Halar 16 = Tefzel 251 = None 252 = Unknown 253 = Special

Table F-42: Transducer block 2 device information block: sensor data -- definitions, defaults, and range of values (continued)

Index	Parameter device information block sensor data	Definition	Default value	Enumerated list of values /range
15	SNS_FlangeType (DD Name : Sensor Flange)	Flange Type	0	0 = ANSI 150 1 = ANSI 300 2 = ANSI 600 5 = PN 40 7 = JIS 10K 8 = JIS 20K 9 = ANSI 900 10 = Sanitary Clamp Fitting 11 = Union 12 = PN 100 252 = Unknown 253 = Special
16	SNS_MassFlow LoSpan (DD Name: Mass Minimum Span)	Mass flow minimum range	Calc	NA
17	SNS_TempFlow LoSpan (DD Name: Temp Minimum Span)	Temperature minimum range	Calc	NA
18	SNS_DensityLoSpan (DD Name: Density Minimum Span)	Density minimum range (g/cc)	Calc	NA

Table F-42: Transducer block 2 device information block: sensor data -- definitions, defaults, and range of values (continued)

Index	Parameter device information block sensor data	Definition	Default value	Enumerated list of values /range
19	SNS_Volume FlowLoSpan (DD Name: Volume Minimum Span)	Volume flow minimum range	Calc	NA
20	SYS_BoardRevision	Board Revision		NA
21	SNS_Hart DeviceID(0) (DD Name: Hart Device ID - 0)	Hart device ID. Mapped with R122 of core		NA
22	SNS_Hart DeviceID(1) (DD Name: Hart Device ID - 1)	Hart device ID. Mapped with R122 of core		NA
23	PA_Preamble_Length	Configures the device preamble number	EIGHT_B YTE = 3	ONE_BYTE = 0 TWO_BYTE = 1 FOUR_BYTE = 2 EIGHT_BYTE = 3
24	EMPTY			
25	EMPTY			
26	EMPTY			
27	EMPTY			
28	EMPTY			

Table F-43: Transducer block 2 device information block: sensor data - size, access, and Modbus register columns

Index	Parameter device information block sensor data	Message type	Data type/ structure	Size	Store /rate (hz)	Access	Modbus register / coil
10	SNS_Sensor SerialNum (DD Name : Sensor Serial Number)	VARIABLE	Unsigned32	4	N	R/W	R-0127-128
11	SNS_SensorType (DD Name: Sensor Model Number)	String	OCTET string	16	N-CP	R/W	R-0425
12	SNS_Sensor TypeCode (DD Name: Sensor Type Code)	ENUM	Unsigned16	2	N	R/W	R-1139
13	NS_SensorMaterial (DD Name : Sensor Material)	ENUM	Unsigned16	2	N-CP	R/W	R-0130
14	SNS_LinerMaterial (DD Name : Sensor Liner)	ENUM	Unsigned16	2	N-CP	R/W	R-0131
15	SNS_FlangeType (DD Name : Sensor Flange)	ENUM	Unsigned16	2	N-CP	R/W	R-0129
16	SNS_MassFlow LoSpan (DD Name: Mass Minimum Span)	VARIABLE	Float	4	D	R	R-181-182

Table F-43: Transducer block 2 device information block: sensor data - size, access, and Modbus register columns (continued)

Index	Parameter device information block sensor data	Message type	Data type/ structure	Size	Store /rate (hz)	Access	Modbus register / coil
17	SNS_TempFlow LoSpan (DD Name: Temp Minimum Span)	VARIABLE	Float	4	D	R	R-183-184
18	SNS_DensityLoSpan (DD Name: Density Minimum Span)	VARIABLE	Float	4	D	R	R-185-186
19	SNS_VolumeFlow LoSpan (DD Name: Volume Minimum Span)	VARIABLE	Float	4	D	R	R-187-188
20	SYS_BoardRevision	VARIABLE	Unsigned8	1	D	R	R-1163
21	SNS_Hart DeviceID(0) (DD Name: Hart Device ID - 0)	VARIABLE	Unsigned32	4	D	R	R-1187
22	SNS_Hart DeviceID(1) (DD Name: Hart Device ID - 1)	VARIABLE	Unsigned32	4	D	R	R-1188
23	PA_Preamble _Length	Simple	Unsigned8	1	N	R/W	R-7136
24	EMPTY			4			
25	EMPTY			4			
26	EMPTY			4			

Table F-43: Transducer block 2 device information block: sensor data - size, access, and Modbus register columns (continued)

Index	Parameter device information block sensor data	Message type	Data type/ structure	Size	Store /rate (hz)	Access	Modbus register / coil
27	EMPTY			4			
28	EMPTY			4			

Transducer block 2 petroleum measurement: API process variables (29-37)

The first table focuses on definitions, default values, and the enumerated list of values allowed for each parameter, while [Table F-45](#) provides the Modbus register column and other relevant values.

Table F-44: Transducer block 2 petroleum measurement: API process variables -- definitions, defaults, and range of values

Index	Parameter device information petroleum measurement API process variables	Definition	Default value	Enumerated list of values /range
29	SNS_API_CorrVolFlow (DD Name : PMI TC Volume Flow)	Temp Corrected Density	----	
30	SNS_API_CorrVolFlow (DD Name : PMI TC Volume Flow)	Temp Corrected (Standard) Volume Flow	---	
31	SNS_API_Ave CorrDensity (DD Name : PM Batch Weighted Average Density)	Batch Weighted Average Density	---	

Table F-44: Transducer block 2 petroleum measurement: API process variables -- definitions, defaults, and range of values (continued)

Index	Parameter device information petroleum measurement API process variables	Definition	Default value	Enumerated list of values /range
32	SNS_API_AveCorrTemp (DD Name : PM Batch Weighted Average Temperature)	Batch Weighted Average Temperature	---	
33	SNS_API_CTL (DD Name :PM CTL)	CTL	---	
34	SNS_API_CorrVolTotal (DD Name : PM TC Volume Total)	Temp Corrected (Standard) Volume Total	0	N/A
35	SNS_API_CorrVolInv (DD Name : PM TC Volume Inventory)	Temp Corrected (Standard) Volume Inventory	0	N/A
36	SNS_ResetApiRefVolTotal (DD Name : Reset PM TC Volume Total)	Reset API Reference Volume Total	-	0x00 = None 0x01 = Reset
37	SNS_ResetAPIGSVInv (DD Name: Reset PM Volume Inventory)	Reset API/GSV Inventory (“On” = Reset, “Off” = N/A)	0x00	0x00 = No effect 0x01 = Reset

Table F-45: Transducer block 2 petroleum measurement: API process variables -- size, access, and Modbus register columns

Index	Parameter device information petroleum measurement API process variables	Message type	Data type/ structure	Size	Store/ rate (hz)	Access	Modbus register / coil
29	SNS_API_CorrDensity (DD Name : PMI TC Density)	RECORD	101	5	D	R	R-0325-326
30	SNS_API_CorrVolFlow (DD Name : PMI TC Volume Flow)	RECORD	101	5	D	R	R-0331-332
31	SNS_API_AveCorrDensity (DD Name : PM Batch Weighted Average Density)	RECORD	101	5	D	R	R-0337-338
32	SNS_API_AveCorrTemp (DD Name : PM Batch Weighted Average Temperature)	RECORD	101	5	D	R	R-339-340
33	SNS_API_CTL (DD Name : PM CTL)	RECORD	101	5	D	R	R-0329-330
34	SNS_API_CorrVolTotal (DD Name : PM TC Volume Total)	VARIABLE	101	5	D/20	R	R-0333-0334

Table F-45: Transducer block 2 petroleum measurement: API process variables -- size, access, and Modbus register columns (continued)

Index	Parameter device information petroleum measurement API process variables	Message type	Data type/ structure	Size	Store/ rate (hz)	Access	Modbus register / coil
35	SNS_API_CorrVolInv (DD Name : PM TC Volume Inventory)	VARIABLE	101	5	D/20	R	R-0335-336
36	SNS_ResetApi RefVolTotal (DD Name : Reset PM TC Volume Total)	METHOD	Unsigned8	1	D	R/W	Coil-0058
37	SNS_Reset APIGSVInv (DD Name: Rest PM Volume Inventory)	METHOD	Unsigned8	1	D	R/W	Coil-0194

Transducer block 2 petroleum measurement: API setup data (38-46)

The first table focuses on definitions, default values, and the enumerated list of values allowed for each parameter, while [Table F-47](#) provides the Modbus register column and other relevant values.

Table F-46: Transducer block 2 petroleum measurement: API setup data -- definitions, defaults, and range of values

Index	Parameter device information petroleum measurement API setup data	Definition	Default value	Enumerated list of values /range
38	SNS_APIRefTemp (DD Name: PM Reference Temp)	API Reference Temp	15.0	0 to 100
39	SNS_APITEC (DD Name: PM Thermal Expansion Coeff)	API Thermal Expansion Coeff	0.001	≥ 0.000485
40	SNS_API2540 TableType (DD Name: PM2540 CTL Table Type)	API 2540 CTLTable Type	API_TABLE_53A	17=Table 5A 18=Table 5B 19= Table 5D 36= Table 6C 49= Table 23A 50= Table 23B 51= Table 23D 68= Table 24C 81 = Table 53A 82 = Table 53B 83 = Table 53D 100 = Table 54C
41	EMPTY			
42	EMPTY			
43	EMPTY			
44	EMPTY			
45	EMPTY			

Table F-46: Transducer block 2 petroleum measurement: API setup data -- definitions, defaults, and range of values (continued)

Index	Parameter device information petroleum measurement API setup data	Definition	Default value	Enumerated list of values /range
46	EMPTY			

Table F-47: Transducer block 2 petroleum measurement: API setup data -- size, access, and Modbus register columns

Index	Parameter device information petroleum measurement API setup data	Message type	Data type/ structure	Size	Store/ rate (hz)	Access	Modbus register / coil
38	SNS_APIRefTemp (DD Name: PM Reference Temp)	VARIABLE	Float	4	D	R/W	R-0319-0320
39	SNS_APITEC (DD Name: PM Thermal Expansion Coeff)	VARIABLE	Float	4	D	R/W	R-0323-0324
40	SNS_API2540 TableType (DD Name: PM2540 CTL Table Type)	ENUM	Unsigned16	2	D	R/W	R-0351
41							
42	EMPTY						
43	EMPTY						
44	EMPTY						

Table F-47: Transducer block 2 petroleum measurement: API setup data -- size, access, and Modbus register columns (continued)

Index	Parameter device information petroleum measurement API setup data	Message type	Data type/ structure	Size	Store/ rate (hz)	Access	Modbus register / coil
45	EMPTY						
46	EMPTY						

Transducer block 2: concentration measurement -- CM process variables (47-53)

The first table focuses on definitions, default values, and the enumerated list of values allowed for each parameter, while [Table F-49](#) provides the Modbus register column and other relevant values.

Table F-48: Transducer block 2: Concentration Measurement -- CM process variables -- definitions, defaults, and range of values

Index	Parameter concentration measurement CM process variables	Definition	Default value	Enumerated list of values /range
47	SNS_ED_RefDens (DD Name : CM Density at Reference)	Density At Reference	----	RECORD
48	SNS_ED_SpecGrav (DD Name : CM Specific Gravity)	Density (Fixed SG Units)	----	RECORD
49	SNS_ED_StdVolFlow (DD Name : CM TC Volume Flow)	Standard Volume Flow Rate	----	RECORD
50	SNS_ED_NetMassFlow (DD Name : CM Net Mass Flow)	Net Mass Flow Rate	----	RECORD

Table F-48: Transducer block 2: Concentration Measurement -- CM process variables -- definitions, defaults, and range of values (continued)

Index	Parameter concentration measurement CM process variables	Definition	Default value	Enumerated list of values /range
51	SNS_ED_NetVolFlow (DD Name : CM Net Volume Flow)	Net Volume Flow Rate	----	RECORD
52	SNS_ED_Conc (DD Name : Concentration)	Concentration	----	RECORD
53	SNS_ED_SpecDens (DD Name : CM Density (Baume))	Density (Fixed Baume Units)	----	RECORD

Table F-49: Transducer block 2: Concentration Measurement -- CM process variables-- size, access, and Modbus register columns

Index	Parameter concentration measurement CM process variables	Message type	Data type/ structure	Size	Store /rate (hz)	Access	Modbus register / coil
47	SNS_ED_RefDens (DD Name : CM Density at Reference)	RECORD	101	5	D	R	R-0963
48	SNS_ED_SpecGrav (DD Name : CM Specific Gravity)	RECORD	101	5	D	R	R-0965
49	SNS_ED_StdVolFlow (DD Name : CM TC Volume Flow)	RECORD	101	5	D	R	R-0967
50	SNS_ED_NetMassFlow (DD Name : CM Net Mass Flow)	RECORD	101	5	D	R	R-0973

Table F-49: Transducer block 2: Concentration Measurement -- CM process variables-- size, access, and Modbus register columns (continued)

Index	Parameter concentration measurement CM process variables	Message type	Data type/ structure	Size	Store /rate (hz)	Access	Modbus register / coil
51	SNS_ED_NetVolFlow (DD Name : CM Net Volume Flow)	RECORD	101	5	D	R	R-0979
52	SNS_ED_Conc (DD Name : Concentration)	RECORD	101	5	D	R	R-0985
53	SNS_ED_SpecDens (DD Name : CM Density (Baume))	RECORD	101	5	D	R	R-0987

Transducer block 2: concentration measurement -- CM totals (54-65)

The first table focuses on definitions, default values, and the enumerated list of values allowed for each parameter, while [Table F-51](#) provides the Modbus register column and other relevant values.

Table F-50: Transducer block 2: Concentration Measurement -- CM totals -- definitions, defaults, and range of values

Index	Parameter concentration measurement CM totals	Definition	Default value	Enumerated list of values / range
54	SNS_ED_StdVolTotal (DD Name : CM TC Volume Total)	Standard Volume Total	0	NA
55	SNS_ED_StdVolInv (DD Name : CM TC Volume Inventory)	Standard Volume Inventory	0	NA
56	SNS_ED _NetMassTotal (DD Name : CM Net Mass Total)	Net Mass Total	0	NA

Table F-50: Transducer block 2: Concentration Measurement -- CM totals -- definitions, defaults, and range of values (continued)

Index	Parameter concentration measurement CM totals	Definition	Default value	Enumerated list of values / range
57	SNS_ED_NetMassInv (DD Name : CM Net Mass Inventory)	Net Mass Inventory	0	NA
58	SNS_ED_NetVolTotal (DD Name : CM Net Volume Total)	Net Volume Total	0	NA
59	SNS_ED_NetVolInv (DD Name : CM Net Volume Inventory)	Net Volume Inventory	0	NA
60	SNS_Reset EDRefVolTotal (DD Name : Reset CM TC Volume Total)	Reset ED Standard Volume Total	-	0x00 = None 0x01 = Reset
61	SNS_Reset EDNetMassTotal (DD Name : Reset CM Net Mass Total)	Reset ED Net Mass Total	-	0x00 = None 0x01 = Reset
62	SNS_Reset EDNetVolTotal (DD Name : Reset CM Net Volume Total)	Reset ED Net Volume Total	-	0x00 = None 0x01 = Reset
63	SNS_ResetEDVolInv (DD Name: Reset Volume Inventory At Reference Temp)	Reset ED Volume Inventory ("On" = Reset, "Off" = N/A)		0x00 = No Effect 0x01 = Reset
64	SNS_Reset EDNetMassInv (DD Name: Reset Net Mass Inventory)	Reset ED Net Mass Inventory ("On" = Reset, "Off" = N/A)		0x00 = No Effect 0x01 = Reset

Table F-50: Transducer block 2: Concentration Measurement -- CM totals -- definitions, defaults, and range of values (continued)

Index	Parameter concentration measurement CM totals	Definition	Default value	Enumerated list of values / range
65	SNS_Reset EDNetVolInv (DD Name: Reset Net Volume Inventory)	Reset ED Net Volume Inventory ("On" = Reset, "Off" = N/A)		0x00 = No Effect 0x01 = Reset

Table F-51: Transducer block 2: Concentration Measurement -- CM totals -- size, access, and Modbus register columns

Index	Parameter concentration measurement CM totals	Message type	Data type/ structure	Size	Store/ rate (hz)	Access	Modbus register / coil
54	SNS_ED_StdVolTotal (DD Name : CM TC Volume Total)	VARIABLE	Float	4	D/20	R	R-0969
55	SNS_ED_StdVolInv (DD Name : CM TC Volume Inventory)	VARIABLE	Float	4	D/20	R	R-0971
56	SNS_ED_NetMassTotal (DD Name : CM Net Mass Total)	VARIABLE	Float	4	D/20	R	R-0975
57	SNS_ED_NetMassInv (DD Name : CM Net Mass Inventory)	VARIABLE	Float	4	D/20	R	R-0977
58	SNS_ED_NetVolTotal (DD Name : CM Net Volume Total)	VARIABLE	Float	4	D/20	R	R-0981

Table F-51: Transducer block 2: Concentration Measurement -- CM totals -- size, access, and Modbus register columns (continued)

Index	Parameter concentration measurement CM totals	Message type	Data type/ structure	Size	Store/ rate (hz)	Access	Modbus register / coil
59	SNS_ED_NetVolInv (DD Name : CM Net Volume Inventory)	VARIABLE	Float	4	D/20	R	R-0983
60	SNS_Reset EDRefVolTotal (DD Name : Reset CM TC Volume Total)	METHOD	Unsigned8	1	S	R/W	Coil-0059
61	SNS_Reset EDNetMassTotal (DD Name : Reset CM Net Mass Total)	METHOD	Unsigned8	1	S	R/W	Coil-0060
62	SNS_Reset EDNetVolTotal (DD Name : Reset CM Net Volume Total)	METHOD	Unsigned8	1	S	R/W	Coil-0060
63	SNS_ResetEDVolInv (DD Name: Reset Volume Inventory At Reference Temp)	METHOD	Unsigned8	1	S	R/W	Coil-0195
64	SNS_Reset EDNetMassInv (DD Name: Reset Net Mass Inventory)	METHOD	Unsigned8	1	S	R/W	Coil-0196

Table F-51: Transducer block 2: Concentration Measurement -- CM totals -- size, access, and Modbus register columns (continued)

Index	Parameter concentration measurement CM totals	Message type	Data type/ structure	Size	Store/ rate (hz)	Access	Modbus register / coil
65	SNS_Reset EDNetVollnv (DD Name: Reset Net Volume Inventory)	METHOD	Unsigned8	1	S	R/W	Coil-0197

Transducer block 2: concentration measurement -- CM setup data (66-102)

The first table focuses on definitions, default values, and the enumerated list of values allowed for each parameter, while [Table F-53](#) provides the Modbus register column and other relevant values.

Table F-52: Transducer block 2: Concentration Measurement -- CM setup data-- definitions, defaults, and range of values

Index	Parameter concentration measurement CM setup data	Definition	Default value	Enumerated list of values /range
66	SNS_ED_CurveLock (DD Name: Lock/Unlock ED Curves)	Lock Enhanced Density Tables	1	0x00 = not locked 0x01 = locked

Table F-52: Transducer block 2: Concentration Measurement -- CM setup data-- definitions, defaults, and range of values (continued)

Index	Parameter concentration measurement CM setup data	Definition	Default value	Enumerated list of values /range
67	SNS_ED_Mode (DD Name: Derived Variable)	Enhanced Density Mode	Mass Conc. (Dens)	0 = None 1 = Dens @ Ref Temp 2 = Specific Gravity 3 = Mass Conc (Dens) 4 = Mass Conc (SG) 5 = Volume Conc (Dens) 6 = Volume Conc (SG) 7 = Concentration (Dens) 8 = Concentration (SG)
68	SNS_ED_ActiveCurve (DD Name: Active Calculation Curve)	Active Calculation Curve	0	0 through 5
69	UNI_ED_CurveIndex (DD Name: Curve Configured)	Curve Configuration Index (n)	---	0 through 5
70	UNI_ED_TemplIndex (DD Name: Curve Temperature Isotherm Index (X-Axis))	Curve Temperature Isotherm Index (x-axis)	---	0 through 5

Table F-52: Transducer block 2: Concentration Measurement -- CM setup data-- definitions, defaults, and range of values (continued)

Index	Parameter concentration measurement CM setup data	Definition	Default value	Enumerated list of values /range
71	UNI_ED_ConcIndex (DD Name: Curve Concentration Index (Y-Axis))	Curven Concentration Index (y-axis)	---	0 through 5
72	SNS_ED_TempISO (DD Name: Curve N (6*5) Temp Isotherm X Value (X-Axis))	Curven (6x5) Temperature Isothermx Value (x-axis)	---	N/A
73	SNS_ED _DensAtTempISO (DD Name: Curve N (6*5) Density @ Temp Isotherm X, Concentration Y)	Curven (6x5) Density @ Temperature IsothermX, ConcentrationY	---	N/A
74	SNS_ED _DensAtTempCoeff (DD Name: Curve N (6*5) Coeff @ Temp Isotherm X, Concentration Y)	Curven (6x5) Coeff @ Temperature IsothermX, ConcentrationY	---	N/A
75	SNS_ED_ConcLabel55 (DD Name: Curve N (6*5) Concentration Y Value (Label For Y-Axis))	Curven (6x5) ConcentrationY Value (Label for y-axis)	---	N/A

Table F-52: Transducer block 2: Concentration Measurement -- CM setup data-- definitions, defaults, and range of values (continued)

Index	Parameter concentration measurement CM setup data	Definition	Default value	Enumerated list of values /range
76	SNS_ED_DensAtConc (DD Name: Curve N (5*1) Density @ Concentration Y (At Ref Temp))	Curven (5x1) Density at ConcentrationY (at Ref Temp)	---	N/A
77	SNS_ED _DensAtConcCoeff (DD Name: Curve N (5*1) Coeff @ Concentration Y (At Ref Temp))	Curven (5x1) Coeff at ConcentrationY (at Ref Temp)	---	N/A
78	SNS_ED_ConcLabel51 (DD Name: Curve N (5*1) Concentration Y Value (Y-Axis))	Curven (5x1) ConcentrationY Value (y- axis))	---	N/A
79	SNS_ED_RefTemp (DD Name: Curve N Reference Temperature)	Curven Reference Temperature	---	Temp. sensor Limits
80	SNS_ED _SGWaterRefTemp (DD Name: Curve N Water Reference Temperature)	Curven SG Water Reference Temperature	---	Temp. sensor Limits
81	SNS_ED _SGWaterRefDens (DD Name: Curve N Water Reference Density)	Curven SG Water Reference Density	---	Density Limits

Table F-52: Transducer block 2: Concentration Measurement -- CM setup data-- definitions, defaults, and range of values (continued)

Index	Parameter concentration measurement CM setup data	Definition	Default value	Enumerated list of values /range
82	SNS_ED_SlopeTrim (DD Name: Curve N Trim Slope)	Curven Slope Trim	---	0.8 to 1.2
83	SNS_ED_OffsetTrim (DD Name: Curve N Trim Offset)	Curven Offset Trim	---	None
84	SSNS_ED _ExtrapAlarmLimit (DD Name: Curve N Alarm Limit (%))	Curven Extrapolation Alarm Limit: %	---	0 to 270
85	SNS_ED_CurveName (DD Name: Curve N Curve Name)	Curven ASCII String – Name of Curve – 12 chars supported	---	N/A
86	SNS_ED_MaxFitOrder (DD Name: Curve Fit Max Order)	Maximum Fit Order for 5x5 curve	---	2, 3, 4, 5
87	SNS_ED_FitResults (DD Name: Curve N Fit Results)	Curven Curve Fit Results	---	0 = Good 1 = Poor 2 = Failed 3 = Empty

Table F-52: Transducer block 2: Concentration Measurement -- CM setup data-- definitions, defaults, and range of values (continued)

Index	Parameter concentration measurement CM setup data	Definition	Default value	Enumerated list of values /range
88	SNS_ED _ConcUnitCode (DD Name: Curve N Concentration Units)	Curven Concentration Units Code	---	1110 = Degrees Twaddell 1426= Degrees Brix 1111= Deg Baume (heavy) 1112= Deg Baume (light) 1343=% sol/wt 1344=% sol/vol 1427= Degrees Balling 1428= Proof Per Volume 1429 = Proof Per mass 1346 = Percent Plato
89	SNS_ED_ExpectedAcc (DD Name: Curve N Curve Fit Expected Accuracy)	Curven Curve Fit Expected Accuracy	---	
90	SNS_ED_ResetFlag (DD Name: Reset All Curve Information)	Reset All Enhanced Density Curve Information	1	0x00 = Not used 0x01 =Reset
91	SNS_ED_Enable DensLowExtrap (DD Name: Enable Density Low)	Enable Dens Low Extrap (Enhanced Density Extrap Alarm)	1	0x00 = Disable 0x01 = Enable

Table F-52: Transducer block 2: Concentration Measurement -- CM setup data-- definitions, defaults, and range of values (continued)

Index	Parameter concentration measurement CM setup data	Definition	Default value	Enumerated list of values /range
92	SNS_ED_Enable DensHighExtrap (DD Name: Enable Density High)	Enable Dens High Extrap (Enhanced Density Extrap Alarm)	1	0x00 = Disable 0x01 = Enable
93	SNS_ED_Enable TempLowExtrap (DD Name: Enable Temperature Low)	Enable Temp Low Extrap (Enhanced Denisty Extrap Alarm)	1	0x00 = Disable 0x01 = Enable
94	SNS_ED_Enable TempHighExtrap (DD Name: Enable Temperature High)	Enable Temp High Extrap (Enhanced Denisty Extrap Alarm)	1	0x00 = Disable 0x01 = Enable
95	DB_SNS_Puck DeviceTypeCode (DD Name: Puck Device Type)	Device Type Code for attached Core		40 = 700 CP 50 = 80 CP
96	SNS_ED_ConcUnits	Curven Concentration Units	{'N','O','N','E',' ',' ',' ',' '}	N/A
97	SNS_MflowText	Special unit massflow text	{'N','O','N','E',' ',' ',' ',' '}	N/A
98	SNS_MtotText	Special unit massTotal text	{'N','O','N','E',' ',' ',' ',' '}	N/A
99	SNS_VflowText	Special unit Volume Flow text	{'N','O','N','E',' ',' ',' ',' '}	N/A
100	SNS_VtotText	Special unit Volume text	{'N','O','N','E',' ',' ',' ',' '}	N/A
101	SNS_GSVflowText	Special unit GSV Volume Flow text	{'N','O','N','E',' ',' ',' ',' '}	N/A

Table F-52: Transducer block 2: Concentration Measurement -- CM setup data-- definitions, defaults, and range of values (continued)

Index	Parameter concentration measurement CM setup data	Definition	Default value	Enumerated list of values /range
102	SNS_GSVtotText	Special unit Volume Total text	{'N','O','N','E' ;';';';';'}	N/A
103	SNS_StartStopTotals (DD Name: Start/Stop All Totalizers)	Start/Stop all Totalizers	0x01	0x00 = Stop Totals 0x01 = Start Totals
104	SNS_ResetAllTotal	Reset all totals	-	0x00 = None 0x01 = Reset
105	SNS_Reset AllInventories	Reset all Inventories	-	0x00 = None 0x01 = Reset
106	SNS_ResetMassTotal (DD Name: Reset Mass Total)	Reset Mass Total	-	0x00 = None 0x01 = Reset
107	SNS_ResetLineVolTotal (DD Name: Reset Volume Total)	Reset Volume Total	-	0x00 = None 0x01 = Reset
108	EMPTY			
109	Transducer Block 2 View 1			

Table F-53: Transducer block 2: Concentration Measurement -- CM setup data -- size, access, and Modbus register columns

Index	Parameter concentration measurement CM setup data	Message type	Data type/ structure	Size	Store/ rate (hz)	Access	Modbus register / coil
66	SNS_ED_CurveLock (DD Name: Lock/Unlock ED Curves)	ENUM	Unsigned8	1	S	R/W	Coil-0085
67	SNS_ED_Mode (DD Name: Derived Variable)	ENUM	Unsigned16	2	N-CP	R/W	R-0524
68	SNS_ED_ActiveCurve (DD Name: Active Calculation Curve)	VARIABLE	Unsigned16	2	N-CP	R/W	R-0523
69	UNI_ED_CurveIndex (DD Name: Curve Configured)	VARIABLE	Unsigned8	1	D	R/W	R-0527
70	UNI_ED_TempIndex (DD Name: Curve Temperature Isotherm Index (X-Axis))	VARIABLE	Unsigned8	1	D	R/W	R-0528
71	UNI_ED_ConcIndex (DD Name: Curve Concentration Index (Y-Axis))	VARIABLE	Unsigned8	1	D	R/W	R-0529

Table F-53: Transducer block 2: Concentration Measurement -- CM setup data -- size, access, and Modbus register columns (continued)

Index	Parameter concentration measurement CM setup data	Message type	Data type/ structure	Size	Store/ rate (hz)	Access	Modbus register / coil
72	SNS_ED_TempISO (DD Name: Curve N (6*5) Temp Isotherm X Value (X-Axis))	VARIABLE	Float	4	N-CP	R/W	R-0531
73	SNS_ED _DensAtTempISO (DD Name: Curve N (6*5) Density @ Temp Isotherm X, Concentration Y)	VARIABLE	Float	4	N-CP	R/W	R-0533
74	SNS_ED_Dens AtTempCoeff (DD Name: Curve N (6*5) Coeff @ Temp Isotherm X, Concentration Y)	VARIABLE	Float	4	D	R	R-0535
75	SNS_ED _ConcLabel55 (DD Name: Curve N (6*5) Concentration Y Value (Label For Y-Axis))	VARIABLE	Float	4	N-CP	R/W	R-0537
76	SNS_ED _DensAtConc (DD Name: Curve N (5*1) Density @ Concentration Y (At Ref Temp))	VARIABLE	Float	4	N-CP	R/W	R-0539

Table F-53: Transducer block 2: Concentration Measurement -- CM setup data -- size, access, and Modbus register columns (continued)

Index	Parameter concentration measurement CM setup data	Message type	Data type/ structure	Size	Store/ rate (hz)	Access	Modbus register / coil
77	SNS_ED_Dens AtConcCoeff (DD Name: Curve N (5*1) Coeff @ Concentration Y (At Ref Temp))	VARIABLE	Float	4	D	R	R-0541
78	SNS_ED _ConcLabel51 (DD Name: Curve N (5*1) Concentration Y Value (Y-Axis))	VARIABLE	Float	4	N-CP	R/W	R-0543
79	SNS_ED_RefTemp (DD Name: Curve N Reference Temperature)	VARIABLE	Float	4	N-CP	R/W	R-0545
80	SNS_ED_SG WaterRefTemp (DD Name: Curve N Water Reference Temperature)	VARIABLE	Float	4	N-CP	R/W	R-0547
81	SNS_ED_SG WaterRefDens (DD Name: Curve N Water Reference Density)	VARIABLE	Float	4	N-CP	R/W	R-0549
82	SNS_ED_SlopeTrim (DD Name: Curve N Trim Slope)	VARIABLE	Float	4	N-CP	R/W	R-0551

Table F-53: Transducer block 2: Concentration Measurement -- CM setup data -- size, access, and Modbus register columns (continued)

Index	Parameter concentration measurement CM setup data	Message type	Data type/ structure	Size	Store/ rate (hz)	Access	Modbus register / coil
83	SNS_ED_OffsetTrim (DD Name: Curve N Trim Offset)	VARIABLE	Float	4	N-CP	R/W	R-0553
84	SSNS_ED _ExtrapAlarmLimit (DD Name: Curve N Alarm Limit (%))	VARIABLE	Float	4	N-CP	R/W	R-0555
85	SNS_ED_CurveName (DD Name: Curve N Curve Name)	VARIABLE	OCTET string	12	N-CP	R/W	R-2771- 2776
86	SNS_ED _MaxFitOrder (DD Name: Curve Fit Max Order)	VARIABLE	Unsigned16	2	N-CP	R/W	R-0564
87	SNS_ED_FitResults (DD Name: Curve N Fit Results)	ENUM	Unsigned16	2	D	R	R-0569
88	SNS_ED _ConcUnitCode (DD Name: Curve N Concentration Units)	ENUM	Unsigned16	2	N-CP	R/W	R-0570
89	SNS_ED _ExpectedAcc (DD Name: Curve N Curve Fit Expected Accuracy)	VARIABLE	Float	4	D	R	R-0571
90	SNS_ED_ResetFlag (DD Name: Reset All Curve Information)	METHOD	Unsigned8	1	N-CP	R/W	Coil-249

Table F-53: Transducer block 2: Concentration Measurement -- CM setup data -- size, access, and Modbus register columns (continued)

Index	Parameter concentration measurement CM setup data	Message type	Data type/ structure	Size	Store/ rate (hz)	Access	Modbus register / coil
91	SNS_ED_Enable DensLowExtrap (DD Name: Enable Density Low)	METHOD	Unsigned8	1	N-CP	R/W	Coil-250
92	SNS_ED_Enable DensHighExtrap (DD Name: Enable Density High)	METHOD	Unsigned8	1	N-CP	R/W	Coil-251
93	SNS_ED_Enable TempLowExtrap (DD Name: Enable Temperature Low)	METHOD	Unsigned8	1	N-CP	R/W	Coil-252
94	SNS_ED_Enable TempHighExtrap (DD Name: Enable Temperature High)	METHOD	Unsigned8	1	N-CP	R/W	Coil-253
95	DB_SNS_Puck DeviceTypeCode (DD: Name: Puck Device Type)	VARIABLE	Unsigned16	2	D/20	R	R-1162
96	SNS_ED_ConcUnits	VARIABLE	String	8	N-CP	R/W	R- 573-576
97	SNS_MflowText	String	OCTET STRING	8	N	R/W	R-52-55
98	SNS_MtotText	String	OCTET string	8	N	R/W	R-56-59

Table F-53: Transducer block 2: Concentration Measurement -- CM setup data -- size, access, and Modbus register columns (continued)

Index	Parameter concentration measurement CM setup data	Message type	Data type/ structure	Size	Store/ rate (hz)	Access	Modbus register / coil
99	SNS_VflowText	String	OCTET string	8	N	R/W	R- 60-63
100	SNS_VtotText	String	OCTET string	8	N	R/W	R-64-67
101	SNS_GSVflowText	String	OCTET string	8	N	R/W	R2607-2610
102	SNS_GSVtotText	String	OCTET string	8	N	R/W	R2611-2614
103	SNS_StartStopTotals DD Name: Start/Stop All Totalizers	METHOD	Unsigned8	1	D	R/W	Coil-0002
104	SNS_ResetAllTotal	METHOD	Unsigned8	1	D	R/W	Coil-0003
105	SNS_Reset AllInventories	METHOD	Unsigned8	1	D	R/W	Coil-0004
106	SNS_ResetMassTotal DD Name: Reset Mass Total	METHOD	Unsigned8	1	D	R/W	Coil-0056
107	SNS_Reset LineVolTotal DD Name: Reset Volume Total	METHOD	Unsigned8	1	D	R/W	Coil-0057
108	EMPTY						
109	Transducer Block 2 View 1						

F.2.6 Transducer block 2 object and views

The following tables show the transducer block 2 object and views.

Transducer block 2 object

- Transducer block 2 object:: [Table F-54](#)

- Transducer block 2 view #1: [Table F-55](#)
- Transducer block 2 view #2: [Table F-56](#)

Table F-54: Transducer block 2 object

Slot/ Index	Element name	Data type	Size in bytes	Value
Slot 12/ Index 0	Reserved	Unsigned 8	1	250 (default)
	Block_Object	Unsigned 8	1	03
	Parent_Class	Unsigned 8	1	03
	Class	Unsigned 8	1	128 (manufacturer-specific class)
	DD_Reference	Unsigned 32	4	00,00,00,00 (reserved)
	DD_Revision	Unsigned 16	2	00,00 (reserved)
	Profile	Octet string	2	64 02 (compact class B)
	Profile_Revision	Unsigned 16	2	03 01 (3.01)
	Execution_Time	Unsigned 8	1	00 (for future use)
	Number-Of_Parameters	Unsigned 16	2	00 98(Maximum number of Transducer Block 2 Parameters)
	Address_of_View_1	Unsigned 16	2	12 98 (slot, index)
	Number_of_VIEWS	Unsigned 8	1	01 (1 view)

Transducer block 2 (device information, API, and CM) views

The following tables show the views for transducer block 2.

Table F-55: Transducer block 2 view #1 -- standard parameters

OD index	Parameter mnemonic -- standard parameters	View 1	View 2	View 3	View 4
0	BLOCK_OBJECT				
1	ST_REV	2			
2	TAG_DESC				
3	STRATEGY				
4	ALERT_KEY				
5	TARGET_MODE				
6	MODE_BLK	3			

Table F-55: Transducer block 2 view #1 -- standard parameters (continued)

OD index	Parameter mnemonic -- standard parameters	View 1	View 2	View 3	View 4
7	ALARM_SUM	8			
	Overall sum of bytes in View Object	13			

Table F-56: Transducer block 2 view #2 -- standard parameters

OD index	Parameter mnemonic -- standard parameters	View 1	View 2	View 3	View 4
98	Overall sum of bytes in View Object (+ 13 Standard parameters bytes)	13			

F.2.7 I & M functions

The following tables show the parameters for I & M functions.

I & M IM-Default parameter

The following tables show the values for the IM-Default parameter. The first table focuses on definitions, default values, and the enumerated list of values allowed, while [Table F-58](#) provides the Modbus register column and other relevant values.

Note

The index entry for all items in this topic is 255.

Table F-57: I & M values for IM-Default parameter -- definitions, defaults, and range of values in sub-index 65000

Definition I&M 0 (Mandatory)	Default value	Enumerated list of values /range
HEADER -Reserved	0x00	---
MANUFACTURER_ID – Identification code of the Manufacturer of the PA Device	0x00	---
ORDER_ID –Order No. of the Device	2700S Profibus PA	---
SERIAL_NO –Production Serial No. of the device	----	---
HARDWARE_REVISION –Revision No. of the Hardware	0xFFFF	---
SOFTWARE_REVISION –Software or Firmware revision	----	---

Table F-57: I & M values for IM-Default parameter -- definitions, defaults, and range of values in sub-index 65000 (continued)

Definition I&M 0 (Mandatory)	Default value	Enumerated list of values /range
REV_COUNTER – According to /I&M/. The REV_COUNTER is incremented if a parameter content with static attribute in the according slot has Changed. Slot 0 carries a REV_COUNTER that counts all changes of static parameters of the whole device.	0	---
PROFILE_ID –Profile type of supporting Profile	0x9700	---
PROFILE_SPECIFIC_TYPE –Specific Profile Type	0x01 0x01	---
M_VERSION –Implemented version of I & M function	0x01 0x01	---
IM_SUPPORTED –Indicated Availability of I & M Records	0x00 0x07	---

Table F-58: I & M values for IM-Default parameter -- size, access, and Modbus register columns in sub-index 65000

Definition I&M 0 (Mandatory)	Message type VARIABLE	Data type/ structure OCTET string	Size 64	Store /rate (hz)	Access R	Modbus register / coil --
HEADER	String	Octet string	10	S	R	Hard Coded
MANUFACTURER_ID	VARIABLE	Unsigned16	2	S	R	Physical Block Index 26 DEVICE_MAN_ID
ORDER_ID	String	Visible string	20	S	R	R 2545 – 2554

Table F-58: I & M values for IM-Default parameter -- size, access, and Modbus register columns in sub-index 65000 (continued)

Definition I&M 0 (Mandatory)	Message type VARIABLE	Data type/ structure OCTET string	Size 64	Store /rate (hz)	Access R	Modbus register / coil --
SERIAL_NO.	String	Visible string	16	S	R	Physical Block Index 28 – DEVICE_SER_NUM
HARDWARE _REVISION	VARIABLE	Unsigned16	2	S	R	0xFFFF
SOFTWARE _REVISION	VARIABLE	1Char 3 Unsigned8	4	S	R	V 0xFF 0xFF 0xFF
REV_COUNTER	VARIABLE	Unsigned16	2	S	R	Sum of ST_REV of all Blocks such as: TB1 + TB2+ AI1+AI2 +AI3+AI4+ TOT1+TOT2 +TOT3+TOT4 + AO1+AO2
PROFILE_ID	VARIABLE	Unsigned16	2	S	R	Hard Coded
PROFILE_SPECIFIC_TY PE	VARIABLE	Octet string	2	S	R	Byte 0:BLOCK _OBJECT.BlockObje ct Byte 1:BLOCK_OBJECT .ParentClass
M_VERSION	VARIABLE	2 – Unsigned8	2	S	R	Hard Coded

Table F-58: I & M values for IM-Default parameter -- size, access, and Modbus register columns in sub-index 65000 (continued)

Definition I&M 0 (Mandatory)	Message type VARIABLE	Data type/ structure OCTET string	Size 64	Store /rate (hz)	Access R	Modbus register / coil --
IM_SUPPORTED	VARIABLE	Octet string	2	S	R	Hard Coded

I & M values for IM-1 parameter

The following tables show the values for the IM-1 parameter. The first table focuses on definitions, default values, and the enumerated list of values allowed, while [Table F-60](#) provides the Modbus register column and other relevant values.

Note

The index entry for all items in this topic is 255.

Table F-59: I & M values for IM-1 parameter -- definitions, defaults, and range of values in sub-index 65001

Definition I&M 1 (Mandatory)	Default value ---	Enumerated list of values /range
HEADER -Manufacture Specific	0x00	----
TAG_FUNCTION –Device Identification Tag	Blank 0x20	---
TAG LOCATION –Device Identification Tag	Blank 0x20	---

Table F-60: I & M values for IM-1 parameter -- size, access, and Modbus register columns in sub-index 65001

Definition I&M 1 (Mandatory)	Message type VARIABLE	Data type/ structure OCTET string	Size	Store/ rate (hz)	Access R	Modbus register / coil --
HEADER - Manufacture Specific	String	OCTET string	10	S	R	Hard Coded

Table F-60: I & M values for IM-1 parameter -- size, access, and Modbus register columns in sub-index 65001 (continued)

Definition I&M 1 (Mandatory)	Message type VARIABLE	Data type/ structure OCTET string	Size	Store/ rate (hz)	Access R	Modbus register / coil --
TAG_FUNCTION -Device Identification Tag	String	Visible string	32	S	R	Physical Block Index 18 TAG_DESC
TAG LOCATION -Device Identification Tag	String	Visible string	22	S	R	Hard Coded

I & M values for IM-2 parameter

The following tables show the values for the IM-2 parameter. The first table focuses on definitions, default values, and the enumerated list of values allowed, while [Table F-62](#) provides the Modbus register column and other relevant values.

Note

The index entry for all items in this topic is 255.

Table F-61: I & M values for IM-2 parameter -- definitions, defaults, and range of values in sub-index 65002

Definition I&M 2 (Mandatory)	Default value ---	Enumerated list of values /range
HEADER -Manufacture Specific	0x00	----
Date – Date of installation of PA Device	Blank 0x20	---
Reserved	0x00	----

Table F-62: I & M values for IM-2 parameter -- size, access, and Modbus register columns in sub-index 65002

Definition I&M 2 (Mandatory)	Message type VARIABLE	Data type/ structure OCTET string	Size	Store/ rate (hz)	Access R	Modbus register / coil --
HEADER -Manufacture Specific	String	OCTET string	10	S	R	Hard Coded
Date -Date of installation of PA Device	String	Visible string	16	S	R	Physical Block Index 38 DEVICE _INSTALL_DATE
Reserved	String	OCTET string	38	S	R	---

I & M values for the PA_IM_0 parameter

The following tables show the values for the PA_IM_0 parameter. The first table focuses on definitions, default values, and the enumerated list of values allowed, while [Table F-64](#) provides the Modbus register column and other relevant values.

Note

The index entry for all items in this topic is 255.

Table F-63: I & M values for PA_IM_0 parameter -- definitions, defaults, and range of values in sub-index 65016

Definition	Default value	Enumerated list of values /range
Header – Reserved	0x00	Hard Coded
PA_IM_VERSION – Version of the process device profile specific extensions of I&M Octet 1 (MSB) = major version number, for example 1 of version 1.0 Octet 2 (LSB) = minor version number, for example 0 of version 1.0	0x01 0x00	Hard Coded
HARDWARE_REVISION – Hardware Revision according to Physical Component	Blank	Physical Block – Index-25

Table F-63: I & M values for PA_IM_0 parameter -- definitions, defaults, and range of values in sub-index 65016 (continued)

Definition	Default value	Enumerated list of values /range
SOFTWARE_REVISION – Firmware Revision of the according Physical Component	Blank	Physical Block – Index-24
Reserved		
PA_IM_SUPPORTED	0x00 0x00	Hard Coded

Table F-64: I & M values for PA_IM_0 parameter -- size, access, and Modbus register columns in sub-index 65016

Definition I&M 2	Message type	Data type / structure	Size	Store /rate (hz)	Access	Modbus register / coil --
Header – Reserved	String	OCTET string	10	S	R	Hard Coded
PA_IM_VERSION	VARIABLE	Unsigned8	2	S	R	Hard Coded
HARDWARE_REVISION	String	Visible string	16	S	R	Physical Block Index 25
SOFTWARE_REVISION	String	Visible string	16	S	R	Physical Block Index 24
Reserved			18			
PA_IM_SUPPORTED	String	OCTET string	2	S	R	Hard Coded

F.2.8 Analog Input (AI) function block parameters

The following tables show the parameters for AI function block.

AI standard PA parameters (16-25)

The following tables show the parameters for the AI standard PA parameters (16-25). The first table focuses on definitions, default values, and the enumerated list of values allowed

for each parameter, while [Table F-66](#) provides the Modbus register column and other relevant values.

Table F-65: AI function block standard PA parameters -- definitions, defaults, and range of values

Index	Parameter Mnemonic Standard Parameters	Definition	Default value	Enumerated list of values /range
16	BLOCK_OBJECT	This object contains the characteristics of the block.	----	NA
17	ST_REV	A block has static block parameters that are not changed by the process. Values are assigned to this parameter during the configuration of optimization. The value of ST_REV increases by 1 after every change of a static block parameter.	0	NA
18	TAG_DESC	Every block can be assigned a textual TAG description. The TAG_DESC must be unambiguous and unique in the field bus system.	''	NA
19	STRATEGY	Grouping of function block. The STRATEGY field can be used to group blocks.	0	NA
20	ALERT_KEY	This parameter contains the identification number of the plant unit.	0	NA
21	TARGET_MODE	This parameter contains desired mode normally set by a control application of an operator. The modes are valid alternatively only; for example, only one mode can be set at one time. A write access to this parameter with more than one mode is out of the range of the parameter and has to be rejected.	AUTO (0x08)	0x8 -- Auto 0x10 – Manual 0x80 – Out of Service
22	MODE_BLK	This parameter contains the current mode and the permitted and normal mode of the block.	----	NA
23	ALARM_SUM	This parameter contains the current states of the block alarms.	0,0,0,0	NA
24	BATCH	This parameter is intended to be used in Batch applications in line with IEC 61512 Part1. Only Function Blocks carry this parameter. There is no algorithm necessary within a Function Block.	0,0,0,0	NA

Table F-65: AI function block standard PA parameters -- definitions, defaults, and range of values (continued)

Index	Parameter Mnemonic Standard Parameters	Definition	Default value	Enumerated list of values /range
25	Reserved			

Table F-66: AI block standard PA parameters -- size, access, and Modbus register columns

Index	Parameter Mnemonic Standard Parameters	Message type	Data type/ structure	Size	Store/ rate (hz)	Access	Modbus register / coil
16	BLOCK_OBJECT	RECORD	DS-32	20	Cst	R	NA
17	ST_REV	SIMPLE	Unsigned16	2	N	R	NA
18	TAG_DESC	SIMPLE	OCTET string	32	S	R/W	NA
19	STRATEGY	SIMPLE	Unsigned16	2	S	R/W	NA
20	ALERT_KEY	SIMPLE	Unsigned8	1	S	R/W	NA
21	TARGET_MODE	SIMPLE	Unsigned8	1	S	R/W	R-1506
22	MODE_BLK	RECORD	DS-37	3	D	R	R-1507
23	ALARM_SUM	RECORD	DS-42	8	D	R	NA
24	BATCH	RECORD	DS-67	10	S	R/W	NA
25	RESERVED						

AI function block standard parameters (26-61)

The following tables show the parameters for the AI function block parameters (26-61). The first table focuses on definitions, default values, and the enumerated list of values allowed for each parameter, while [Table F-68](#) provides the Modbus register column and other relevant values.

Table F-67: AI function block standard parameters -- definitions, defaults, and range of values

Index	Parameter device information block transmitter data	Definition	Default value	Enumerated list of values /range
26	OUT (DD Name: AI Out)	The Function Block parameter OUT contains the current measurement value in a vendor-specific or configuration-adjusted engineering unit and the belonging state in AUTO MODE. The Function Block parameter OUT contains the value and status set by an operator in MAN MODE.	----	NA
27	PV_SCALE (DD Name: AI PV Scale)	Conversion of the Process Variable into percent using the high and low scale values.	100.00	NA
28	OUT_SCALE (DD Name: AI Out Scale)	Scale of the Process Variable	100.00	NA
29	LIN_TYPE (DD Name: AI Linearization Type)	Type linearization.	1	NA
30	CHANNEL (DD Name: AI Channel)	Reference to the active Transducer Block which provides the measurement value to the Function Block.	---	NA
31	Reserved			
32	PV_FTIME (DD Name: AI PV Filter Time)	Filter time of the Process Variable.	0	NA
33	Reserved			
34	Reserved			

Table F-67: AI function block standard parameters -- definitions, defaults, and range of values (continued)

Index	Parameter device information block transmitter data	Definition	Default value	Enumerated list of values /range
35	ALARM_HYS (DD Name: AI Alarm Hys)	Hysteresis	0.5% of the range	N/A
36	Reserved			
37	HI_HI_LIM (DD Name: AI Hi Hi Lim)	Value for upper limit of alarms	Max Value	N/A
38	Reserved			
39	HI_LIM (DD Name: AI Hi Lim)	Value for upper limit of warnings	Max Value	N/A
40	Reserved			
41	LO_LIM (DD Name: AI Lo Lim)	Value for lower limit of warnings	Min Value	N/A
42	Reserved			
43	LO_LO_LIM (DD Name: AI Lo Lo Lim)	Value for the lower limit of alarms	Min Value	N/A
44	Reserved			
45	Reserved			
46	Reserved			
47	Reserved			
48	Reserved			

Table F-67: AI function block standard parameters -- definitions, defaults, and range of values (continued)

Index	Parameter device information block transmitter data	Definition	Default value	Enumerated list of values /range
49	Reserved			
50	SIMULATE (DD Name: AI Simulate)	For commissioning and test purposes the input value from the Transducer Block in the Analog Input Function Block AI-FB can be modified.	Disable	N/A
51	Reserved			
52	Reserved			
53	Reserved			
54	Reserved			
55	Reserved			
56	Reserved			
57	Reserved			
58	Reserved			
59	Reserved			
60	Reserved			
61	AI BLOCK VIEW1			

Table F-68: AI function block standard parameters -- size, access, and Modbus register columns

Index	Parameter device information block transmitter data	Message type	Data type/ structure	Size	Store/ rate (hz)	Access	Modbus register / coil
26	OUT (DD Name: AI Out)	RECORD	101	5	D	R/W Can be written only in Manual Mode.	NA
27	PV_SCALE (DD Name: AI PV Scale)	ARRAY	Float	8	S	R/W	NA
28	OUT_SCALE (DD Name: AI Out Scale)	RECORD	DS-36	11	S	R/W	R-1509 (Only units)
29	LIN_TYPE (DD Name: AI Linearization Type)	SIMPLE	Unsigned8	1	S	R/W	R-1510
30	CHANNEL (DD Name: AI Channel)	SIMPLE	Unsigned16	2	S	R/W	R-1508
31	Reserved						
32	PV_FTIME (DD Name: AI PV Filter Time)	SIMPLE	Float	4	S	R/W	N/A
33	Reserved						
34	Reserved						

Table F-68: AI function block standard parameters -- size, access, and Modbus register columns (continued)

Index	Parameter device information block transmitter data	Message type	Data type/ structure	Size	Store/ rate (hz)	Access	Modbus register / coil
35	ALARM_HYS (DD Name: AI Alarm Hys)	SIMPLE	Float	4	S	R/W	N/A
36	Reserved						
37	HI_HI_LIM (DD Name: AI Hi Hi Lim)	SIMPLE	Float	4	S	R/W	N/A
38	Reserved						
39	HI_LIM (DD Name: AI Hi Lim)	SIMPLE	Float	4	S	R/W	N/A
40	Reserved						
41	LO_LIM (DD Name: AI Lo Lim)	SIMPLE	Float	4	S	R/W	N/A
42	Reserved						
43	LO_LO_LIM (DD Name: AI Lo Lo Lim)	SIMPLE	Float	4	S	R/W	N/A
44	Reserved						
45	Reserved						
46	Reserved						
47	Reserved						
48	Reserved						

Table F-68: AI function block standard parameters -- size, access, and Modbus register columns (continued)

Index	Parameter device information block transmitter data	Message type	Data type/ structure	Size	Store/ rate (hz)	Access	Modbus register / coil
49	Reserved						
50	SIMULATE (DD Name: AI Simulate)	RECORD	DS-50	6	S	R/W	N/A
51	Reserved						
52	Reserved						
53	Reserved						
54	Reserved						
55	Reserved						
56	Reserved						
57	Reserved						
58	Reserved						
59	Reserved						
60	Reserved						
61	AI BLOCK VIEW1						

F.2.9 Analog input block objects and views

The following tables show the analog input block object and views. There are four AI blocks.

Analog input block objects

- AI block objects: [Table F-69](#)
- AI block view #1: [Table F-70](#)
- AI block view #2: [Table F-71](#)

Table F-69: Analog Input block objects

Slot/ Index	Element name	Data type	Size in bytes	Value
Slots 1, 2, 3, 5 /Index 16	Reserved	Unsigned 8	1	250 (default)
	Block_Object	Unsigned 8	1	02 (function block)
	Parent_Class	Unsigned 8	1	01 (input)
	Class	Unsigned 8	1	01 (AI)
	DD_Reference	Unsigned 32	4	00 ,00, 00, 00 (reserved)
	DD_Revision	Unsigned 16	2	00 ,00 (reserved)
	Profile	Octet string	2	64 02 (compact class B)
	Profile_Revision	Unsigned 16	2	03 01 (3.01)
	Execution_Time	Unsigned 8	1	00 (for future use)
	Number-Of_Parameters	Unsigned 16	2	00 45 (Maximum number of AI Block Parameters)
	Address_of_View_1	Unsigned 16	2	AI1 = 01 61 (slot, index) AI2 = 02 61 (slot, index) AI3 = 03 61 (slot, index) AI4 = 05 61 (slot, index)
	Number_of_Views	Unsigned 8	1	01 (1 view)

AI function block views

The following tables show the views for the AI block.

Table F-70: AI block view #1

OD index	Parameter mnemonic -- standard parameters	View 1	View 2	View 3	View 4
16	BLOCK_OBJECT				
17	ST_REV	2			
18	TAG_DESC				
19	STRATEGY				
20	ALERT_KEY				
21	TARGET_MODE				
22	MODE_BLK	3			

Table F-70: AI block view #1 (continued)

OD index	Parameter mnemonic -- standard parameters	View 1	View 2	View 3	View 4
23	ALARM_SUM	8			
	Overall sum of bytes in View Object	13			

Table F-71: AI block view #2 -- standard parameters

OD index	Parameter mnemonic -- standard parameters	View 1	View 2	View 3	View 4
26	Out	5			
61	Overall sum of bytes in View Object (+ 13 Standard parameters bytes)	5 + 13			

F.2.10 AO function block parameters

The following tables show the parameters for A0 function block.

A0 standard PA parameters (16-24)

The following tables show the parameters for the A0 standard PA parameters (16-24). The first table focuses on definitions, default values, and the enumerated list of values allowed for each parameter, while [Table F-73](#) provides the Modbus register column and other relevant values.

Table F-72: A0 standard PA parameters -- definitions, defaults, and range of values

Index	Parameter mnemonic Standard PA parameters	Definition	Default value	Enumerated list of values /range
16	BLOCK_OBJECT	This object contains the characteristics of the block.	----	NA
17	ST_REV	A block has static block parameters that are not changed by the process. Values are assigned to this parameter during the configuration of optimization. The value of ST_REV increases by 1 after every change of a static block parameter.	0	NA

**Table F-72: A0 standard PA parameters -- definitions, defaults, and range of values
(continued)**

Index	Parameter mnemonic Standard PA parameters	Definition	Default value	Enumerated list of values /range
18	TAG_DESC	Every block can be assigned a textual TAG description. The TAG_DESC must be unambiguous and unique in the field bus system.	''	NA
19	STRATEGY	Grouping of function block. The STRATEGY field can be used to group blocks.	0	NA
20	ALERT_KEY	This parameter contains the identification number of the plant unit.	0	NA
21	TARGET_MODE	This parameter contains desired mode normally set by a control application of an operator. The modes are valid alternatively only; for example, only one mode can be set at one time. A write access to this parameter with more than one mode is out of the range of the parameter and has to be rejected.	AUTO (0x08)	0x8 -- Auto 0x10 – Manual 0x80 – Out of Service
22	MODE_BLK	This parameter contains the current mode and the permitted and normal mode of the block.	---	NA
23	ALARM_SUM	This parameter contains the current states of the block alarms.	0,0,0,0	NA
24	BATCH	This parameter is intended to be used in Batch applications in line with IEC 61512Part1. Only Function Blocks carry this parameter. There is no algorithm necessary within a Function Block.	0,0,0,0	NA

Table F-73: A0 standard PA parameters -- size, access, and Modbus register columns

Index	Parameter mnemonic Standard PA parameters	Message type	Data type/structure	Size	Store/rate (hz)	Access	Modbus register / coil
16	BLOCK_OBJECT	RECORD	DS-32	20	Cst	R	NA
17	ST_REV	SIMPLE	Unsigned16	2	N	R	NA
18	TAG_DESC	SIMPLE	OCTET STRING	32	S	R/W	NA
19	STRATEGY	SIMPLE	Unsigned16	2	S	R/W	NA
20	ALERT_KEY	SIMPLE	Unsigned8	1	S	R/W	NA
21	TARGET_MODE	SIMPLE	Unsigned8	1	S	R/W	R-2295
22	MODE_BLK	RECORD	DS-37	3	D	R	R-2296
23	ALARM_SUM	RECORD	DS-42	8	D	R	NA
24	BATCH	RECORD	DS-67	10	S	R/W	NA

A0 function block standard PA parameters (25-61)

The following tables show the parameters for the A0 standard PA parameters (25-61). The first table focuses on definitions, default values, and the enumerated list of values allowed for each parameter, while [Table F-75](#) provides the Modbus register column and other relevant values.

Table F-74: A0 function block standard parameters -- definitions, defaults, and range of values

Index	Parameter information A0 function block standard parameters	Definition	Default value	Enumerated list of values /range
25	SP (DD Name: AO Set Point)	Set point	----	NA
26	Reserved			

Table F-74: AO function block standard parameters -- definitions, defaults, and range of values (continued)

Index	Parameter information AO function block standard parameters	Definition	Default value	Enumerated list of values /range
27	PV_SCALE (DD Name: AO PV Scale)	Conversion of the PV in engineering units to PV in percent as the input value of the Function Block.	100, .00%	NA
28	READBACK (DD Name: AO ReadBack Value)	The actual position of the final control element within the travel span (between OPEN and CLOSE position) in units of PV_SCALE.	----	NA
29	Reserved			
30	Reserved			
31	Reserved			
32	Reserved			
33	Reserved			
34	Reserved			
35	Reserved			
36	Reserved			
37	IN_CHANNEL (DD Name: AO IN Channel)	Reference to the active Transducer Block and its parameter that provides the actual position of the final control element.	---	N/A

Table F-74: AO function block standard parameters -- definitions, defaults, and range of values (continued)

Index	Parameter information AO function block standard parameters	Definition	Default value	Enumerated list of values /range
38	OUT_CHANNEL (DD Name: AO OUT Channel)	Reference to the active Transducer Block and its parameter that provides the position value for the final control element.	----	N/A
39	FSAFE_TIME (DD Name: AO Fail Safe Time)	Time in seconds from detection of failure of the actual used set point (SP = BAD or RCAS_IN <> GOOD) to the action of the block if the condition still exists.	0	N/A

Table F-74: A0 function block standard parameters -- definitions, defaults, and range of values (continued)

Index	Parameter information A0 function block standard parameters	Definition	Default value	Enumerated list of values /range
40	FSAFE_TYPE (DD Name: AO Fail Safe Type)	Defines reaction of the device, if a failure of the actual used set point is still detected after FSAFE_TIME or if the status of actual used set point is Initiate FailSafe.	2	<p>0: value FSAFE_VALUE is used as set point status of OUT = UNCERTAIN – Substitute Value</p> <p>1: use last valid set point status of OUT = UNCERTAIN – Last usable Value or B–D – No communication, no LUV</p> <p>2: actuator goes to fail-safe position defined by ACTUATOR_ACTION (only useful for actuators with spring return) status of OUT = B–D – non specific</p>
41	FSAFE_VALUE (DD Name: AO Fail Safe Value)	Set point is used if FSAFE_TYPE = 1 and FSAFE is activated.	0	N/A
42	Reserved			
43	Reserved			
44	Reserved			
45	Reserved			
46	Reserved			

Table F-74: AO function block standard parameters -- definitions, defaults, and range of values (continued)

Index	Parameter information AO function block standard parameters	Definition	Default value	Enumerated list of values /range
47	POS_D (DD Name: AO POS_D)	The current position of the valve	---	0: not initialized 1: closed 2: opened 3: intermediate
48	Reserved			
49	CHECK_BACK (DD Name: AO Check Back)	Detailed information of the device, bitwise coded. More than one message is possible at once.	----	N/A
50	CHECK_BACK_MASK (DD Name: AO Check Back Mask)	Definition of supported CHECK_BACK information bits.	---	0: not supported 1: supported
51	SIMULATE (DD Name: AO Simulate)	For commissioning and maintenance reasons, it is possible to simulate the READBACK by defining the value and the status.	Disabled	N/A

Table F-74: AO function block standard parameters -- definitions, defaults, and range of values (continued)

Index	Parameter information AO function block standard parameters	Definition	Default value	Enumerated list of values /range
52	INCREASE_CLOSE (DD Name: AO Increase Close)	Direction of positioned in mode Rcas and Auto	0	0: rising (increasing of set point input results in OPENING of the valve) 1: falling (increasing of set point input results in CLOSING of the valve)
53	OUT (DD Name: AO Out)	This parameter is the process variable of the AO Block in engineering units in AUTO mode and is the value specified by the operator in Manual mode.	----	N/A
54	OUT_SCALE (DD Name: AO Out Scale)	Scale of the Process Variable.	---	N/A
55	Reserved			
56	Reserved			
57	Reserved			
58	Reserved			
59	Reserved			
60	Reserved			
61	Reserved			
62	Reserved			

Table F-74: AO function block standard parameters -- definitions, defaults, and range of values (continued)

Index	Parameter information AO function block standard parameters	Definition	Default value	Enumerated list of values /range
63	Reserved			
64	Reserved			
65	AO BLOCK VIEW1			

Table F-75: AO function block standard parameters -- size, access, and Modbus register columns

Index	Parameter information AO function block standard parameters	Message type	Data type/ structure	Size	Store/ rate (hz)	Access	Modbus register / coil
25	SP (DD Name: AO Set Point)	RECORD	101	5	D	R/W	NA
26	Reserved						
27	PV_SCALE (DD Name: AO PV Scale)	RECORD	DS-36	11	S	R/W	R-2298 (Only units)
28	READBACK (DD Name: AO Readback Value)	RECORD	101	5	D	R	NA
29	Reserved						
30	Reserved						
31	Reserved						
32	Reserved						
33	Reserved						
34	Reserved						

Table F-75: AO function block standard parameters -- size, access, and Modbus register columns (continued)

Index	Parameter information AO function block standard parameters	Message type	Data type/ structure	Size	Store/ rate (hz)	Access	Modbus register / coil
35	Reserved						
36	Reserved						
37	IN_CHANNEL (DD Name: AO IN Channel)	SIMPLE	Unsigned16	2	S	R/W	R-2297
38	OUT_CHANNEL (DD Name: AO OUT Channel)	SIMPLE	Unsigned16	2	S	----	R-2275 -- AO Out Channel R-2299 -- AO Out Scale Units R2298 -- AO PV Scale Units
39	FSAFE_TIME (DD Name: AO Fail Safe Time)	SIMPLE	Float	4	S	R/W	N/A
40	FSAFE_TYPE (DD Name: AO Fail Safe Type)	SIMPLE	Unsigned8	1	S	R/W	N/A
41	FSAFE_VALUE (DD Name: AO Fail Safe Value)	SIMPLE	Float	4	S	R/W	N/A
42	Reserved						
43	Reserved						

Table F-75: AO function block standard parameters -- size, access, and Modbus register columns (continued)

Index	Parameter information AO function block standard parameters	Message type	Data type/ structure	Size	Store/ rate (hz)	Access	Modbus register / coil
44	Reserved						
45	Reserved						
46	Reserved						
47	POS_D (DD Name: AO POS_D)	RECORD	102	2	D	R	N/A
48	Reserved						
49	CHECK_BACK (DD Name: AO Check Back)	SIMPLE	Octet String	3	D	R	N/A
50	CHECK_BACK_MASK (DD Name: AO Check Back Mask)	SIMPLE	Octet String	3	Cst	R	N/A
51	SIMULATE (DD Name: AO Simulate)	RECORD	DS-50	6	S	R/W	N/A
52	INCREASE_CLOSE (DD Name: AO Increase Close)	SIMPLE	Unsigned8	1	S	R/W	N/A
53	OUT (DD Name: AO Out)	RECORD	101	5	D	R/W (Can be written only in Manual Mode.)	N/A

Table F-75: AO function block standard parameters -- size, access, and Modbus register columns (continued)

Index	Parameter information AO function block standard parameters	Message type	Data type/ structure	Size	Store/ rate (hz)	Access	Modbus register / coil
54	OUT_SCALE (DD Name: AO Out Scale)	RECORD	DS-36	11	S	R/W	N/A
55	Reserved						
56	Reserved						
57	Reserved						
58	Reserved						
59	Reserved						
60	Reserved						
61	Reserved						
62	Reserved						
63	Reserved						
64	Reserved						
65	AO BLOCK VIEW1						

F.2.11 Analog output block objects and views

The following tables show the AO block object and views. There are two AO blocks, with separate slot assignments.

Analog blocks 1 and 2 output block object

- AO block objects: [Table F-76](#)
- AO block in channel values (slots) [Table F-77](#)
- AO block out channel values (slots) [Table F-78](#)
- AO block view #1: [Table F-79](#)
- AO block view #2: [Table F-80](#)

Table F-76: Analog Output blocks 1 and 2 block object

Slot/ Index	Element name	Data type	Size in bytes	Value
Slot 9 /Index 16	Reserved	Unsigned 8	1	250 (default)
	Block_Object	Unsigned 8	1	02 (function block)
	Parent_Class	Unsigned 8	1	02 (output)
	Class	Unsigned 8	1	01 (AO)
	DD_Reference	Unsigned 32	4	00 ,00, 00, 00 (reserved)
	DD_Revision	Unsigned 16	2	00 ,00 (reserved)
	Profile	Octet string	2	64 02 (compact class B)
	Profile_Revision	Unsigned 16	2	03 01 (3.01)
	Execution_Time	Unsigned 8	1	00 (for future use)
	Number-Of_Parameters	Unsigned 16	2	00 49 (Maximum number of AO1 Block Parameters)
	Address_of_View_1	Unsigned 16	2	AO1 = 09 65 (slot, index) AO2 = 10 65 (slot, index)
	Number_of_Views	Unsigned 8	1	01 (1 view)

AO block channel assignments

Table F-77: AO block In channel values

In channel slot	In channel index	In channel value	Corresponding TB process variable
11 (0x0B)	29(0x1D)	0x0B1D	Temperature
11 (0x0B)	114(0x72)	0x0B72	Pressure

Table F-78: AO block out channel values

Out channel slot	Out channel slot	Out channel slot	Corresponding TB process variable
11 (0x0B)	111(0x6F)	0x0B6F	Temperature
11 (0x0B)	113(0x71)	0x0B71	Pressure

AO function block views

The following tables show the views for the AO block.

Table F-79: AO block view #1

OD index	Parameter mnemonic -- standard parameters	View 1	View 2	View 3	View 4
16	BLOCK_OBJECT				
17	ST_REV	2			
18	TAG_DESC				
19	STRATEGY				
20	ALERT_KEY				
21	TARGET_MODE				
22	MODE_BLK	3			
23	ALARM_SUM	8			
	Overall sum of bytes in View Object	13			

Table F-80: AO block view #2 -- standard parameters

OD index	Parameter mnemonic -- standard parameters	View 1	View 2	View 3	View 4
28	READBACK	5			
47	POS_D	2			
49	CHECK_BACK	3			
61	Overall sum of bytes in View Object (+ 13 Standard parameters bytes)	10+13			

F.2.12 Totalizer block parameters

Totalizer standard PA parameters (16-25)

The following tables show the parameters for the Totalizer block standard PA parameters (16-25). The first table focuses on definitions, default values, and the enumerated list of values allowed for each parameter, while [Table F-82](#) provides the Modbus register column and other relevant values.

Table F-81: Totalizer standard PA parameters -- definitions, defaults, and range of values

Index	Parameter Mnemonic Standard PA Parameters	Definition	Default value	Enumerated list of values /range
16	BLOCK_OBJECT	This object contains the characteristics of the block.	----	NA
17	ST_REV	A block has static block parameters that are not changed by the process. Values are assigned to this parameter during the configuration of optimization. The value of ST_REV increases by 1 after every change of a static block parameter.	0	NA
18	TAG_DESC	Every block can be assigned a textual TAG description. The TAG_DESC must be unambiguous and unique in the field bus system.	''	NA
19	STRATEGY	Grouping of function block. The STRATEGY field can be used to group blocks.	0	NA
20	ALERT_KEY	This parameter contains the identification number of the plant unit.	0	NA
21	TARGET_MODE	This parameter contains desired mode normally set by a control application of an operator. The modes are valid alternatively only; for example, only one mode can be set at one time. A write access to this parameter with more than one mode is out of the range of the parameter and has to be rejected.	AUTO (0x08)	0x8 -- Auto 0x10 – Manual 0x80 – Out of Service
22	MODE_BLK	This parameter contains the current mode and the permitted and normal mode of the block.	---	NA
23	ALARM_SUM	This parameter contains the current states of the block alarms.	0,0,0,0	NA
24	BATCH	This parameter is intended to be used in Batch applications in line with IEC 61512 Part1. Only Function Blocks carry this parameter. There is no algorithm necessary within a Function Block.	0,0,0,0	NA
25	Reserved			

Table F-82: Totalizer standard PA parameters -- size, access, and Modbus register columns

Index	Parameter Mnemonic Standard PA Parameters	Message type	Data type/structure	Size	Store/rate (hz)	Access	Modbus register / coil
16	BLOCK_OBJECT	RECORD	DS-32	20	S	R	NA
17	ST_REV	SIMPLE	Unsigned16	2	N	R	NA
18	TAG_DESC	SIMPLE	OCTET STRING	32	S	R/W	NA
19	STRATEGY	SIMPLE	Unsigned16	2	S	R/W	NA
20	ALERT_KEY	SIMPLE	Unsigned8	1	S	R/W	NA
21	TARGET_MODE	SIMPLE	Unsigned8	1	S	R/W	R-2287
22	MODE_BLK	RECORD	DS-37	3	D	R	R-2288
23	ALARM_SUM	RECORD	DS-42	8	D	R	NA
24	BATCH	RECORD	DS-67	10	S	R/W	NA
25	Reserved						

Totalizer standard parameters (26-53)

The following tables show the parameters for the Totalizer block standard parameters (26-53). The first table focuses on definitions, default values, and the enumerated list of values allowed for each parameter, while [Table F-84](#) provides the Modbus register column and other relevant values.

Table F-83: Totalizer function block standard parameters -- definitions, defaults, and range of values

Index	Parameter mnemonic totalizer function block standard parameters	Definition	Default value	Enumerated list of values /range
26	TOTAL (DD Name: TOT Total)	The Function Block parameter TOTAL contains the integrated quantity of the rate parameter provided by CHANNEL and the associated status.	0	NA

Table F-83: Totalizer function block standard parameters -- definitions, defaults, and range of values (continued)

Index	Parameter mnemonic totalizer function block standard parameters	Definition	Default value	Enumerated list of values /range
27	UNIT_TOT (DD Name: TOT Total Units)	Unit of the totalized quantity	direct integral of the channel value unit	NA
28	CHANNEL (DD Name: TOT Channel)	Reference to the active Transducer Block, which provides the measurement value to the Function Block.	---	NA
29	SET_TOT (DD Name: TOT Set Total)	Reset of the internal value of the FB algorithm to 0, or set this value to PRESET_TOT.	0: TOTALIZE	0: TOTALIZE 1: RESET 2: PRESET
30	MODE_TOT (DD Name: TOT Mode Total)	This Function Block parameter governs the behavior of the totalization.	0: BALANCED	0: BALANCED 1: POS_ONLY 2: NEG_ONLY 3: HOLD
31	FAIL_TOT (DD Name: TOT Fail Total)	Fail-safe mode of the Totalizer Function Block. This parameter governs the behavior of the Function Block during the occurrence of input values with BAD status.	0: RUN	0: RUN 1: HOLD 2: MEMORY
32	PRESET_TOT (DD Name: TOT Preset Total)	This value is used as a preset for the internal value of the FB algorithm. The value is effective if using the SET_TOT function.	0	NA

Table F-83: Totalizer function block standard parameters -- definitions, defaults, and range of values (continued)

Index	Parameter mnemonic totalizer function block standard parameters	Definition	Default value	Enumerated list of values /range
33	ALARM_HYS (DD Name: TOT Alarm Hys)	Hysteresis	0	NA
34	HI_HI_LIM (DD Name: TOT Hi Hi Lim)	Value for upper limit of alarms	Max Value	NA
35	HI_LIM (DD Name: TOT Hi Lim)	Value for upper limit of warnings	Max Value	N/A
36	LO_LIM (DD Name: TOT Lo Lim)	Value for lower limit of warnings	Min Value	NA
37	LO_LO_LIM (DD Name: TOT Lo Lo Lim)	Value for the lower limit of alarms	Min Value	N/A
38	Reserved			
39	Reserved			
40	Reserved			
41	Reserved			
42	Reserved			
43	Reserved			
44	Reserved			
45	Reserved			
46	Reserved			
47	Reserved			
48	Reserved			

Table F-83: Totalizer function block standard parameters -- definitions, defaults, and range of values (continued)

Index	Parameter mnemonic totalizer function block standard parameters	Definition	Default value	Enumerated list of values /range
49	Reserved			
50	Reserved			
51	Reserved			
52	Totalizer Selection (DD Name: TOT Selection)	Selection of Totalizer operation mode	0	0 – Standard (Profile Specific) 1 – Internal Mass Total 2 – Internal Volume Total 3 – Internal Mass Inventory 4 – Internal volume Inventory 5 – Internal GSV Total 6 – Internal GSV Inventory 7 – Internal API CorrVol Total 8 – Internal API CorrVol Inventory 9 – Internal ED_StdVolTotal 10 – Internal ED_StdVolInv 11 – Internal ED_NetMassTotal 12 – Internal ED_NetMassInv 13 – Internal ED_NetVolTotal 14 – Internal ED_NetVolInv
53	TOTALIZER BLOCK VIEW1			

Table F-84: Totalizer function block standard parameters -- size, access, and Modbus register columns

Index	Parameter mnemonic totalizer function block standard parameters	Message type	Data type/ structure	Size	Store/ rate (hz)	Access	Modbus register / coil
26	TOTAL (DD Name: TOT Total)	RECORD	101	5	N	R/W Can be written only in Manual Mode.	NA
27	UNIT_TOT (DD Name: TOT Total Units)	SIMPLE	Unsigned16	2	S	R/W	R-2290
28	CHANNEL (DD Name: TOT Channel)	SIMPLE	Unsigned16	2	S	R/W	R-2289
29	SET_TOT (DD Name: TOT Set Total)	SIMPLE	Unsigned8	1	N	R/W	R-2292
30	MODE_TOT (DD Name: TOT Mode Total)	SIMPLE	Unsigned8	1	N	R/W	R-2293
31	FAIL_TOT (DD Name: TOT Fail Total)	SIMPLE	Unsigned8	1	S	R/W	N/A
32	PRESET_TOT (DD Name: TOT Preset Total)	SIMPLE	Float	4	S	R/W	N/A
33	ALARM_HYS (DD Name: TOT Alarm Hys)	SIMPLE	Float	4	S	R/W	N/A

Table F-84: Totalizer function block standard parameters -- size, access, and Modbus register columns (continued)

Index	Parameter mnemonic totalizer function block standard parameters	Message type	Data type/ structure	Size	Store/ rate (hz)	Access	Modbus register / coil
34	HI_HI_LIM (DD Name: TOT Hi Hi Lim)	SIMPLE	Float	4	S	R/W	N/A
35	HI_LIM (DD Name: TOT Hi Lim)	SIMPLE	Float	4	S	R/W	N/A
36	LO_LIM (DD Name: TOT Lo Lim)	SIMPLE	Float	4	S	R/W	N/A
37	LO_LO_LIM (DD Name: TOT Lo Lo Lim)	SIMPLE	Float	4	S	R/W	N/A
38	Reserved						
39	Reserved						
40	Reserved						
41	Reserved						
42	Reserved						
43	Reserved						
44	Reserved						
45	Reserved						
46	Reserved						
47	Reserved						
48	Reserved						
49	Reserved						
50	Reserved						
51	Reserved						

Table F-84: Totalizer function block standard parameters -- size, access, and Modbus register columns (continued)

Index	Parameter mnemonic totalizer function block standard parameters	Message type	Data type/ structure	Size	Store/ rate (hz)	Access	Modbus register / coil
52	Totalizer Selection (DD Name: TOT Selection)	SIMPLE	Unsigned8	1	S	R/W	R-2291
53	TOTALIZER BLOCK VIEW1						

F.2.13 Totalizer block objects and function block views

The following tables show the totalizer block object and views. There are four totalizer blocks, each with its own slot.

Totalizer block objects

- Totalizer block object: : [Table F-85](#)
- Totalizer block view #1: [Table F-86](#)
- Totalizer block view #2: [Table F-87](#)
- Totalizer block channel assignments [Table F-88](#)

Table F-85: Totalizer block object

Slot/ Index	Element name	Data type	Size in bytes	Value
Slots 04, 06, 07, and 08/	Reserved	Unsigned 8	1	250 (default)
	Block_Object	Unsigned 8	1	02 (function block)
	Parent_Class	Unsigned 8	1	05 (calculation class)
Index 16	Class	Unsigned 8	1	08 (TOT)
	DD_Reference	Unsigned 32	4	00 ,00, 00, 00 (reserved)
	DD_Revision	Unsigned 16	2	00 ,00 (reserved)
	Profile	Octet string	2	64 02 (compact class B)
	Profile_Revision	Unsigned 16	2	03 01 (3.01)
	Execution_Time	Unsigned 8	1	00 (for future use)

Table F-85: Totalizer block object (continued)

Slot/ Index	Element name	Data type	Size in bytes	Value
	Number-Of_Parameters	Unsigned 16	2	00 37 (Maximum number of Totalizer Blocks 1-4 Parameters)
	Address_of_View_1	Unsigned 16	2	<ul style="list-style-type: none"> • TOT1 = 04 53 (slot, index) • TOT2 = 06 53 (slot, index) • TOT3 = 07 53 (slot, index) • TOT4 = 08 53 (slot, index)
	Number_of_VIEWS	Unsigned 8	1	01 (1 view)

Totalizer function block views

The following tables show the totalizer function block views.

Table F-86: Totalizer block view #1

OD index	Parameter mnemonic -- standard parameters	View 1	View 2	View 3	View 4
16	BLOCK_OBJECT				
17	ST_REV	2			
18	TAG_DESC				
19	STRATEGY				
20	ALERT_KEY				
21	TARGET_MODE				
22	MODE_BLK	3			
23	ALARM_SUM	8			
	Overall sum of bytes in View Object	13			

Table F-87: Totalizer block view #2

OD index	Parameter mnemonic -- standard parameters	View 1	View 2	View 3	View 4
26	TOTAL DIAGNOSIS	5			
53	Overall sum of bytes in View Object (+ 13 Standard parameters bytes)	5 + 13			

Table F-88: Totalizer block channel assignments

Channel value			Process variable
Slot	Index	Value	
11 (0x0B)	17 (0x11)	0x0B11	Volume flow
11 (0x0B)	21 (0x15)	0x0B15	Mass flow
11 (0x0B)	25 (0x19)	0x0B19	Density
11 (0x0B)	29 (0x1D)	0x0B1D	Temperature
11 (0x0B)	64 (0x40)	0x0B40	Gas Standard Volume Flow
11 (0x0B)	114 (0x072)	0x0B72	Pressure
11 (0x0B)	160 (0xA0)	0x0BA0	Drive Gain
12 (0x0C)	29 (0x1D)	0x0C1D	API Corrected Density
12 (0x0C)	30 (0x1E)	0x0C1E	API Corrected Volume Flow
12 (0x0C)	31 (0x1F)	0x0C1F	API Average Corrected Density
12 (0x0C)	32 (0x20)	0x0C20	API Average Corrected Temp
12 (0x0C)	33 (0x21)	0x0C21	API CTL
12 (0x0C)	47 (0x2F)	0x0C2F	ED Reference Density
12 (0x0C)	48 (0x30)	0x0C30	ED Specific Gravity
12 (0x0C)	49 (0x31)	0x0C31	ED Standard Volume Flow
12 (0x0C)	50 (0x32)	0x0C32	ED Net Mass Flow
12 (0x0C)	51 (0x33)	0x0C33	ED Net Volume Flow
12 (0x0C)	52 (0x34)	0x0C34	ED Concentration
12 (0x0C)	53 (0x35)	0x0C35	ED Baume

G NE53 history

This appendix documents the change history of the Model 2700 transmitter with PROFIBUS-PA software.

The following table describes the change history of the transmitter software. Operating instructions are English versions. Instructions in other languages have different part numbers but matching revision letters.

Table G-1: Transmitter software change history

Date	Software version	Type	Change	Document revision
09/2000	1.0	Initial release	NA	20000327 Rev. A
08/2001	1.1	Software improvements	Expanded the ability to control totalizers through multiple communication protocols	20000327 Rev. B
02/2002	2.0	Software improvements	<ul style="list-style-type: none"> Improved the handling of RS-485 communication via the service port Improved the user experience with the display Expanded the ability to control totalizers through multiple communication protocols Tightened data synchronization when accessing data via different communication tools. Enhanced volume flow functionality 	20000327 Rev. C 20000327 Rev. C through 20000327 Rev. D 20000327 Rev. C
		Feature additions	Expanded the ability to control totalizers through multiple communication protocols	through 20000327 Rev. E
08/2008	2.2	Software improvements	<ul style="list-style-type: none"> Improved the user experience with the display Increased immunity to line noise 	20000327 Rev. F

Table G-1: Transmitter software change history (continued)

Date	Software version	Type	Change	Document revision
		Feature additions	<ul style="list-style-type: none"> Added drive gain as an Analog Input channel Added the ability to configure blocks without putting them in Out of Service mode. Added improved diagnostic reporting. Added density cutoffs 	
10/2009	3.0	Software improvements	<ul style="list-style-type: none"> Improved EDD more closely matches ProLink III Added petroleum measurement application Added enhanced density application Improved consistency with other Micro Motion 2700 transmitters 	20000327 Rev. FA
		Feature additions	<ul style="list-style-type: none"> Added compatibility with enhanced core processor Added gas standard volume measurement. Added configurable alarm severity Added meter verification Expanded LDO capability 	
10/2010	3.1	Feature additions	<ul style="list-style-type: none"> Added support for Smart Meter Verification Expanded LDO capability 	20000327 Rev. FB
10/2010	3.2	Software improvements	<ul style="list-style-type: none"> Maintenance release 	20000327 Rev. FB
07/2016	4.0	Software improvements	<ul style="list-style-type: none"> Added support to configurable preambles Added alarm A106 Moved some parameters from Transducer Block 1 to Transducer Block 2 per the PROFIBUS specification since they were mapped to reserved indexes. 	20000327 Rev. FC
		Feature additions	<ul style="list-style-type: none"> Added special unit support 	

Table G-1: Transmitter software change history (continued)

Date	Software version	Type	Change	Document revision
08/2017	4.0	Feature additions	<ul style="list-style-type: none"> • Added index entries in "Transducer block 1: standard flow parameters (8-30)". • The R48 register has been mapped to Serial Number (Index 28 DEVICE_SER_NUM) in Physical Block Parameters. 	20000327 Rev. FD



20000327
Rev. FD
2018

Micro Motion Inc. USA

Worldwide Headquarters
7070 Winchester Circle
Boulder, Colorado USA 80301
T +1 303-527-5200
T +1 800-522-6277
F +1 303-530-8459
www.emerson.com

Micro Motion Europe

Emerson Automation Solutions
Neonstraat 1
6718 WX Ede
The Netherlands
T +31 (0) 70 413 6666
F +31 (0) 318 495 556
www.micromotion.nl

Micro Motion Asia

Emerson Automation Solutions
1 Pandan Crescent
Singapore 128461
Republic of Singapore
T +65 6363-7766
F +65 6770-8003

Micro Motion United Kingdom

Emerson Automation Solutions
Emerson Process Management Limited
Horsfield Way
Bredbury Industrial Estate
Stockport SK6 2SU U.K.
T +44 0870 240 1978
F +44 0800 966 181

©2018 Micro Motion, Inc. All rights reserved.

The Emerson logo is a trademark and service mark of Emerson Electric Co. Micro Motion, ELITE, ProLink, MVD and MVD Direct Connect marks are marks of one of the Emerson Automation Solutions family of companies. All other marks are property of their respective owners.

MICRO MOTION™

