

890 Series Loading Arm Counterbalance

H32469PA
 March 2012

The 890 Series Hi-Load Counterbalance represents the best available technology in loading arm counterbalancing. Today's applications demand higher spring loads to accommodate longer reaches and additional equipment that is commonly specified on loading arms. The 890 delivers by providing roughly 50% more spring capacity than our previous generation counterbalance.



890 Series Counterbalance

BENEFITS

- **Easy, Precise Adjustment** – A simple turn of adjustment bolt provides finite adjustment to tune your loading arm to desired balance point.
- **No Special Tools Required** – Standard Socket Wrench
- **Wide Range of Motion** – 80° of motion (55° up and 25° down)
- **Stable Balancing** – Through the entire range of motion
- **Integral Upward & Downward Travel Stops** – Fully adjustable to limit the range to your application
- **Safe, Robust Design** – Tested under full-load conditions for over 100,000 cycles with no degradation in performance

SPECIFICATIONS

Type: Right-Hand/Left-Hand Hi-Load Loading Arm Counter Balance

Working Temperature Range: -50° F - 176° F (-46° C to +80° C)

SELECTION GUIDE

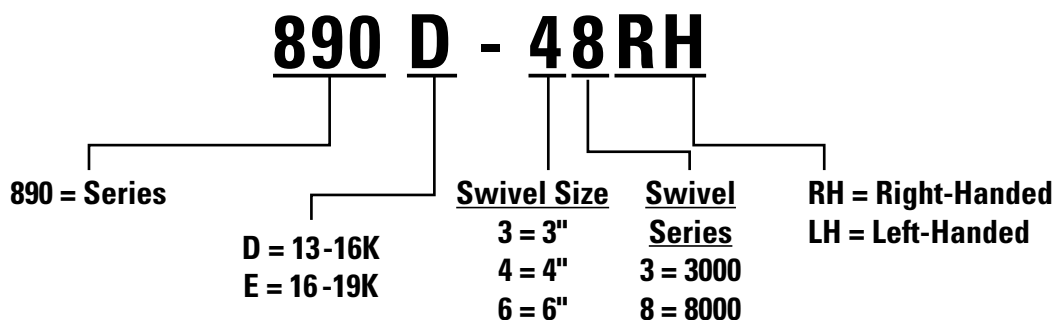

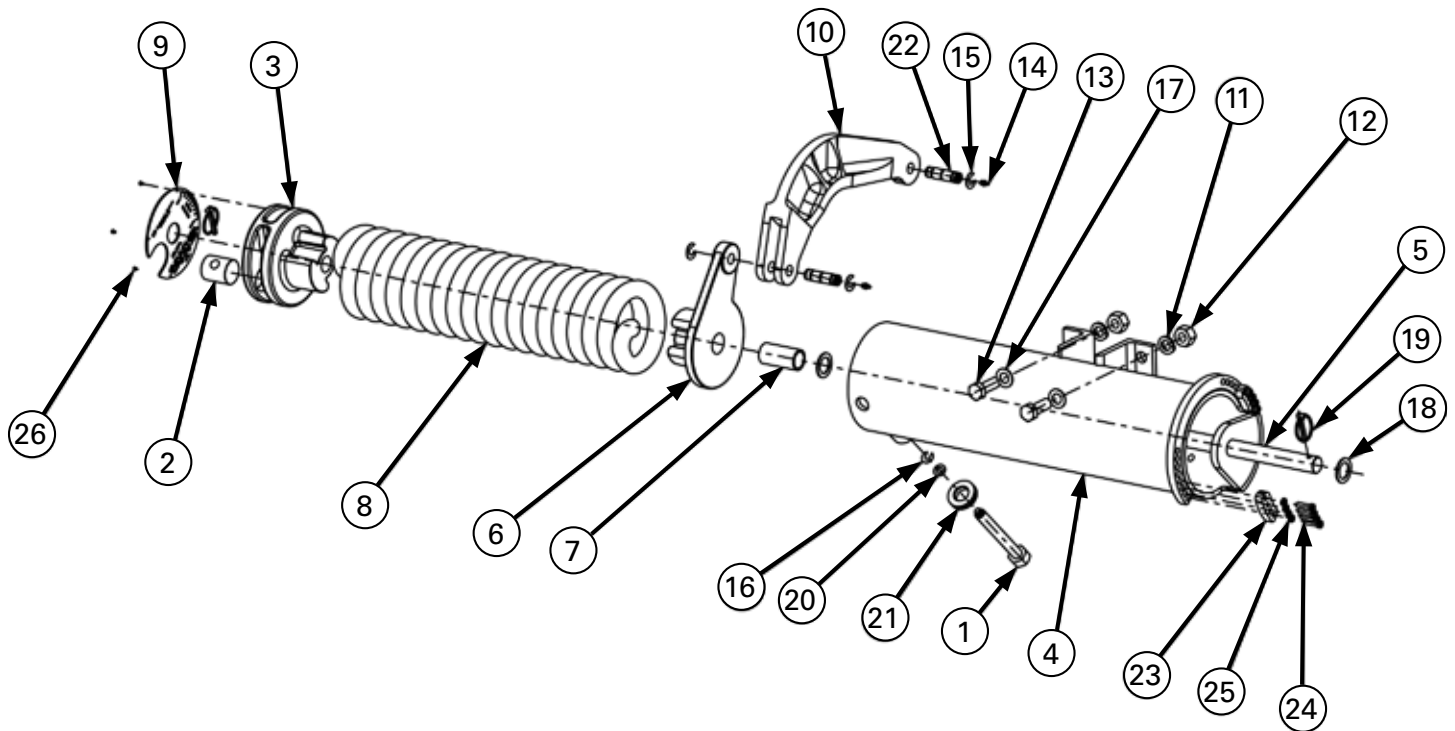

• **Note:** 890D, Right-Handed Spring Assembly Shown. Some part numbers would vary for other spring sizes and orientations. Consult factory for assistance.

#	Qty	Description	890D-48RH	890D-48LH	890E-48RH	890E-48LH
1	1	Bolt, Adjustment, 890 HLTS, SST	C-21557-M	C-21557-M	C-21557-M	C-21557-M
2	1	Nut, Barrel, 890 HLTS, SST	C-21399-M	C-21399-M	C-21399-M	C-21399-M
3	1	End Cap, 890 HLTS, DI	C-21401-DI	C-21401-DI	C-21401-DI	C-21401-DI
4	1	Housing Assy, 890 HLTS, Lo Temp CST/ SST, RH, 4"	C-21588	C-21564	C-21588	C-21564
5	1	Shaft, 890 HLTS, SST	C-21558-M	C-21558-M	C-21558-M	C-21558-M
6	1	Spring Arm, 890 HLTS, RH, DI	C-21404-DI	C-21496-DI	C-21404-DI	C-21496-DI
7	1	Bushing, Spring Arm, 890 HLTS, BRZ	C-21405-M	C-21405-M	C-21405-M	C-21405-M
8	1	Torsion Spring (Spring Coil Color)	C-21465-M (White)	C-21466-M (Black)	C-21406-M (Blue)	C-21407-M (Green)
9	1	Nameplate, 890 HLTS, Alum	C-21495-M	C-21495-M	C-21495-M	C-21495-M
10	1	Link Arm, DI	E-20041-DI	E-20041-DI	E-20041-DI	E-20041-DI
11	4	Lockwasher, CP, 5/8"	H-02507-M	H-02507-M	H-02507-M	H-02507-M
12	4	Nut, 5/8-11	H-04740-M	H-04740-M	H-04740-M	H-04740-M
13	4	Screw, Hex Cap, CST, ZP, 5/8"-11 x 1-3/4"	H-05910-M	H-05910-M	H-05910-M	H-05910-M
14	2	Grease Fitting, SST, 1/4-28	H-06713-M	H-06713-M	H-06713-M	H-06713-M
15	4	Retaining Ring, CST, 5/8"	H-30321-M	H-30321-M	H-30321-M	H-30321-M
16	1	Retaining Ring, SST	H-30345-M	H-30345-M	H-30345-M	H-30345-M
17	4	Washer, Flat	H-30361-M	H-30361-M	H-30361-M	H-30361-M
18	2	Washer, Flat, CP/ZP, 1"	H-32280-M	H-32280-M	H-32280-M	H-32280-M
19	2	Pin, Linch, CST ZP, 1-4"	H-32281-M	H-32281-M	H-32281-M	H-32281-M
20	1	Washer, Flat, CP/ZP, 5/8"	H-32388-M	H-32388-M	H-32388-M	H-32388-M
21	1	Washer, Spherical, CST ZP, 5/8"	H-32393-M	H-32393-M	H-32393-M	H-32393-M
22	2	Pin, Link Arm, Greasable, SST, 5/8"	H-32394-M	H-32394-M	H-32394-M	H-32394-M
23	2	Bumper Stop, 890 HLTS, CST	H-32421-M	H-32421-M	H-32421-M	H-32421-M
24	8	Screw, Cap, Socket Head, ZP, 5/16"-18	H-31278-M	H-31278-M	H-31278-M	H-31278-M
25	8	Washer, Lock, ZP, 2 1/64"	H-03563-M	H-03563-M	H-03563-M	H-03563-M
26	4	Drive Screw, Type U, #4 X 3/16 LG, SST	H-32299-M	H-32299-M	H-32299-M	H-32299-M

IMPORTANT: OPW products should be used in compliance with applicable federal, state, provincial, and local laws and regulations. Product selection should be based on physical specifications and limitations and compatibility with the environment and materials to be handled. OPW MAKES NO WARRANTY OF FITNESS FOR A PARTICULAR USE. All illustrations and specifications in this literature are based on the latest product information available at the time of publication. OPW reserves the right to make changes at any time in prices, materials, specifications, and models and to discontinue models without notice or obligation.

UPWARD/DOWNWARD TRAVEL STOPS

The 890 is equipped with integral upward and downward travel stops. This allows you to limit the travel of your loading arm to avoid obstructions that may be at your site (e.g., overhead lighting or pipe racks).



Adjustment is very simple:
Position Bumper Stop(s) in the desired positions and secure with four (4) supplied cap screws and lock washers.

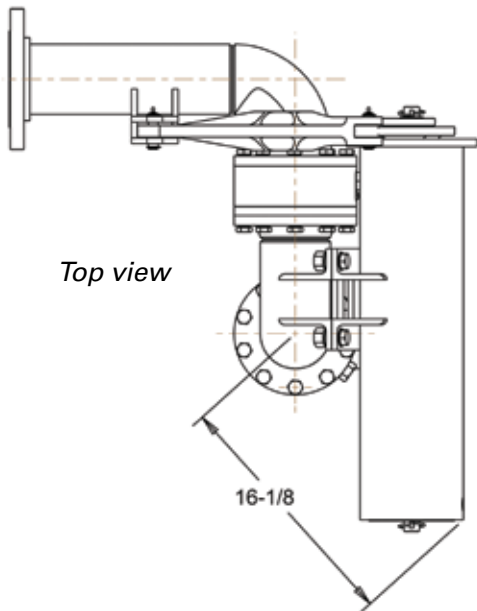

IMPORTANT: A minimum clearance of approximately 17" is required for the Spring balance to clear any obstruction.

ADJUSTMENT

When to Adjust:

- A. To raise loading arm higher or for more lifting action **INCREASE** torque
- B. To decrease loading arm vertical travel or to slow the rate at which the arm rises, **DECREASE** torque
- C. **Note:** Prior to any disassembly, Spring balance tension should be completely relieved to allow safe disassembly of level arm



ADJUSTMENT CONT.

Torque:

For more lifting action increase torque.

For less lifting action decrease torque.

Note: The ADJUSTMENT BOLT mechanism provides significant mechanical advantage during adjustment. It is recommended that the loading arm be raised to a minimum of 60° above horizontal during adjustment.

- Place 1-1/16" socket wrench on **ADJUSTMENT BOLT**.
- To **INCREASE** torque rotate **ADJUSTMENT BOLT** clockwise.
- To **DECREASE** torque rotate the **ADJUSTMENT BOLT** counter-clockwise.
- Release wrench and test loading arm lifting action.



Note: Prior to any loading arm disassembly, spring tension should be completely relieved.

Note: Right hand spring balance shown.

MAINTENANCE

LUBRICATION	<p>Pins [22] should be lubricated on an annual basis. Any bearing gel that meets local conditions would be acceptable.</p>
	<p>Shaft [5] should be lubricated on an annual basis.</p> <ol style="list-style-type: none"> 1. Raise loading arm to highest position to unload spring. Secure arm. 2. Mark end cap [3] position, and loosen adjustment bolt [1]. Adjustment bolt should move easily with spring unloaded. 3. Remove pin [19] and washer [18] from end cap side of shaft. 4. Move shaft [5] 2-inches from housing and cover extended shaft with grease. (Recommend heavy bearing grease such as Royal Purple, Thermasil T-100) 5. Complete maintenance in reverse order.

- Consider using an OPW Lock Down Unit with the 890 Spring.

SAFETY

DANGER! Before performing any maintenance, always secure the Loading Arm and remove all tension from the counterbalance – a torsion spring. The Loading Arm counterbalance spring contains a substantial amount of stored energy. You must relieve this energy before any disassembly. Failure to remove all tension from the counterbalance spring of the Loading Arm before maintenance may cause serious personal injury or death.



WARNING

Failure to follow these warnings could result in serious personal injury, property damage or product failure.

1) While installing and using the Loading Arm, always wear adequate personal protection, including hard hats, gloves, and steel-toed work boots. Failure to wear adequate personal protection may cause serious personal injury and death.

2) Always follow the procedures prescribed in this Document. Failing to follow the procedures prescribed may damage the Loading Arm and cause serious personal injury and death. Consult Loading Arm Installation, Maintenance & Safety Manual for more details.