

rotork[®]
Controls

LA-2500 Series
Instruction Manual

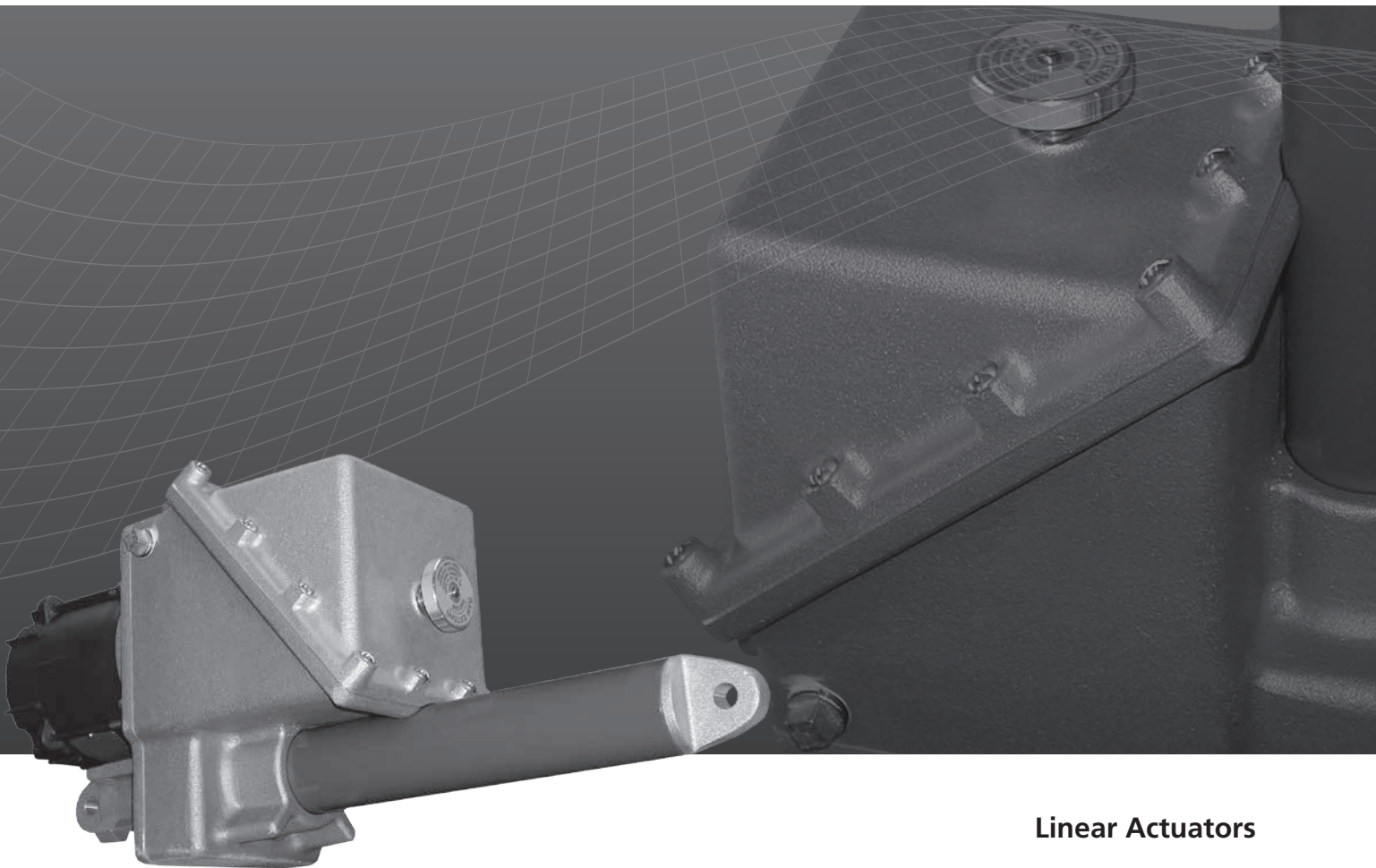

Linear Actuators

Redefining Flow Control

Contents

rotork® Controls

Section	Page
General Information	3
Product Specifications	5
Installation	6
Typical Wiring Diagram	8
Start-up and Calibration	11
LA-2520-D Amplifier Setup and Calibration	13
HART Calibration	14
HART Setup Information	15
Troubleshooting Guide	17
Repair and Maintenance	19
Parts Identification	23
Major Dimensions	33
Hazardous Locations	34

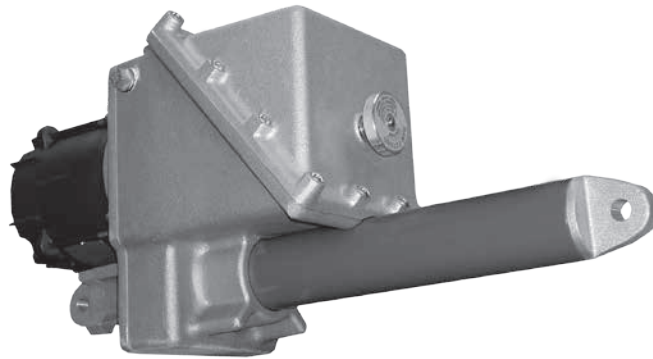

THIS MANUAL CONTAINS IMPORTANT SAFETY INFORMATION. PLEASE ENSURE IT IS THOROUGHLY READ AND UNDERSTOOD BEFORE INSTALLING, OPERATING OR MAINTAINING THE EQUIPMENT.

ALL SECTIONS WITH THE SYMBOL  MUST BE READ AND UNDERSTOOD.

FAILURE TO PROPERLY WIRE TORQUE/THRUST SWITCHES WILL RESULT IN ACTUATOR DAMAGE.

REFER TO THE SPECIFIC WIRING DIAGRAM SUPPLIED WITH YOUR ACTUATOR FOR CORRECT WIRING.

DUE TO WIDE VARIATIONS IN THE TERMINAL NUMBERING OF ACTUATOR PRODUCTS, ACTUAL WIRING OF THIS DEVICE SHOULD FOLLOW THE PRINT SUPPLIED WITH THE UNIT.

General Information

INTRODUCTION

Rotork Controls designs, manufactures, and tests its products to meet many national and international standards. For these products to operate within their normal specifications, they must be properly installed and maintained. The following instructions must be followed and integrated with your safety program when installing, using and maintaining Rotork Controls products:

- Read and save all instructions prior to installing, operating and servicing this product.
- If you do not understand any of the instructions, contact your Rotork Controls representative for clarification.
- Follow all warnings, cautions and instructions marked on, and supplied with, the product.
- Inform and educate personnel in the proper installation, operation and maintenance of the product.
- Install equipment as specified in Rotork Controls installation instructions and per applicable local and national codes. Connect all products to the proper electrical sources.
- To ensure proper performance, use qualified personnel to install, operate, update, tune and maintain the product.
- When replacement parts are required, ensure that the qualified service technician uses replacement parts specified by Rotork Controls. Substitutions may result in fire, electrical shock, other hazards, or improper equipment operation.
- Keep all product protective covers in place (except when installing, or when maintenance is being performed by qualified personnel), to prevent electrical shock, personal injury or damage to the actuator.

WARNING

Before installing the actuator, make sure that it is suitable for the intended application. If you are unsure of the suitability of this equipment for your installation, consult Rotork Controls prior to proceeding.

WARNING - SHOCK HAZARD

Installation and servicing must be performed only by qualified personnel.

WARNING - EXTERNAL CIRCUITS

Some are designed to be hazardous live (limit switches). Care must be taken during install.

WARNING - ELECTROSTATIC DISCHARGE

This electronic control is static-sensitive. To protect the internal components from damage, never touch the printed circuit cards without using electrostatic discharge (ESD) control procedures.

WARNING - CONDUIT TEMPERATURE

CONDUIT TEMPERATURE COULD REACH 105 °C at a 60 ° ambient.

RECEIVING/INSPECTION

Carefully inspect for shipping damage. Damage to the shipping carton is usually a good indication that it has received rough handling. Report all damage immediately to the freight carrier and Rotork Controls, Inc.

Unpack the product and information packet – taking care to save the shipping carton and any packing material should return be necessary. Verify that the items on the packing list or bill of lading agree with your own.

STORAGE

If the product will not be installed immediately, it should be stored in a clean, dry area where the ambient temperature is not less than -20 °F. The actuator should be stored in a non-corrosive environment. The actuator is not sealed to NEMA 4 until the conduit entries are properly connected.

EQUIPMENT RETURN

A Returned Goods authorization (RG) number is required to return any equipment for repair. This must be obtained from Rotork Controls. (Telephone: 414/461-9200) The equipment must be shipped, freight prepaid, to the following address after the RG number is issued:

Rotork Controls
5607 West Douglas Avenue
Milwaukee, Wisconsin 53218
Attn: Service Department

To facilitate quick return and handling of your equipment, include:

- RG Number on outside of box
- Company Name, Contact Person, Phone/Fax No.
- Address
- Repair Purchase Order Number
- Brief description of the problem

General Information

IDENTIFICATION LABEL

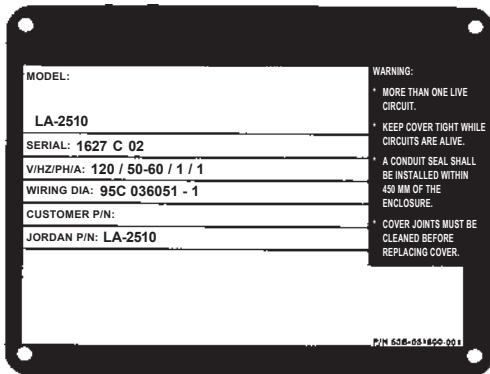

MODEL NUMBER: **LA25 10 Series**

SERIAL NUMBER: **1627 C 02**
 Sequential Number ——— Year Built
 ——— Month Built

ABBREVIATIONS USED IN THIS MANUAL

A or Amps	Ampere
AC	Alternating Current
°C	Degrees Celsius
CW	Clockwise
CCW	Counterclockwise
DC	Direct Current
°F	Degrees Fahrenheit
G	Earth Ground
Hz	Hertz
kg	Kilogram
L	Line (power supply)
lbs.	Pounds
lbf.	Lbs. Force
LVDT	Linear Variable Differential Transformer
mA	Milliamp
mfd	Microfarad
mm	Millimeters
N	Newton (force)
NEMA	National Electrical Manufacturing Association
Nm	Newton Meter
NPT	National Pipe Thread
Ph	Phase
PL	Position Limit Switch
RPM	Revolutions per Minute
sec.	Second
TL	Thrust Limit Switch
VAC	Volts AC
VDC	Volts DC
VR	Variable Resistance
W	Watt

GENERAL ACTUATOR DESCRIPTION

The LA-2520 series actuators are electrically operated, bi-directional linear devices. They are designed for strokes to 24 inches (610 mm) and thrusts to 1,600 lbf (7117 N) and include a manual override handwheel. The drive motor may be single or three phase.

Options Include:

- Up to four independently adjustable limit switches
- Integral or remote servo-amplifiers
- HART field communications
- Trunnion mounting
- 4 to 20mA position feedback
- Shaft bellows
- Paint/coatings

The LA-2500-N models include 120/240 VAC single phase models, 208/240/380/480 VAC three phase models. These actuators are controlled by “switched” power inputs or by a remotely-mounted servo-amplifier.

The LA-2500-D features an internally-mounted servoamplifier. It requires 120 VAC unswitched, single phase line voltage input and a DC analog command signal for a complete, closed-loop positioning system in a compact enclosure.

The HART option communicates with master controllers using the HART (Highway Addressable Remote Transducer) field communication protocol. The HART protocol allows commands, position feedback, and diagnostics to be sent digitally across one pair of current loop wires. Up to 15 actuators, transmitters and other field instruments may be connected to one HART current loop. HART is an open standard supported by the HART Communication Foundation.

LA-2500 Series Product Specifications

GENERAL SPECIFICATIONS

Speed / Thrust: inches per sec. (mm) / lbf. (N)
0.45/800 (11/3558)
0.9/800 (23/3558)
0.9/1200 (23/5338)
0.9/1600 (23/7117)

Stroke

6 to 24 in. (152 to 610 mm)

Lubrication & Type

Permanently lubricated, Chevron SRI Grease #2.

Gearing

Hardened steel spur gear train, self-locking acme screw.

Low Temperature

-40 °F to 150 °F. (-40 °C to 65 °C).

High Temperature

-40 °F to 225 °F. (-40 °C to 107 °C).

Environment Rating

Dust ignition-proof for Class II, Division I, Groups E, F and G, and Type 4 (IP65) indoor and outdoor.

Enclosure Material

Cast Aluminum Alloy.

Approximate Weight

105 lbs. (48 kg)

Mounting

Clevis mount in any position.
Trunnion (not available with 6 in. stroke).

Manual Handcrank

Permits local operation.

Thrust Limiting

Bi-directional (factory set and not adjustable).

Modulating Rate

(1% position changes) 1200 starts/hour

Clevis

Non-rotating front clevis (male).

ELECTRICAL SPECIFICATIONS

Power Requirements

Actuator Model	Input Power Volts/Phase/Hz	Current (Amps)	
		Run	Stall
LA-2510-N	240/480/3/50/60	3/1.5	7.5/3.75
	380/3/50	2.4	4.7
LA-2520-D	120/240/1/50/60	6/3	15/7.5
LA-2520-E	120/240/1/50/60	6/3	15/7.5
LA-2520-N	120/240/1/50/60	6/3	15/7.5

Voltage Tolerance

+/-10%

Conduit Entry:

1¼" NPT & ¾" NPT.

Field Wiring

To barrier terminal blocks.

Command Signal Inputs

HART protocol on locked 4 mA current loop for multidrop applications.

Position Feedback Signal

HART protocol on locked 4 mA current loop.

OPTIONS

Up to four auxiliary position limit switches

5A SPDT, 120/240 VAC

1000 Ohm Feedback Potentiometer

2 Watt Max. DC

4-20 mA Feedback Transmitter

Isolated, loop-powered 12-36 VDC at 25 mA.

Maximum Load (Ohms) = $\frac{\text{Power Supply Voltage} - 8}{0.020 \text{ A}}$

Installation

GENERAL INSTALLATION AND START-UP

Refer to the installation diagram provided with the unit for physical dimensions. Upon initial receipt of the actuator, the actuator clevis is taped to the actuator ram tube at the factory to prevent the actuator ram clevis from turning. If the tape is broken, or if the actuator clevis has been allowed to rotate during initial start-up, the limit switch settings will be affected.

Turning the clevis with the motor stopped will extend or retract the ram without turning the feedback limit switches.

Do not attempt to simply adjust the limit switches to correct the ram travel in the case of the clevis being turned. The unit must be recentered, per the instruction “Re-Centering Ram Travel” in this instruction manual.

Before powering-up the unit, verify the electrical connections again. While following the wiring print supplied with the unit, verify the direction and travel of the ram when power is applied. Also, verify that any feedback devices and other options (such as a heater) are operational. If the LA-2500 does not operate according to the print, re-check the interconnect wiring of the actuator. If problems still occur, follow the Troubleshooting Guide included in this manual. If the problem persists, contact a Rotork Controls service representative for further assistance.

MECHANICAL INSTALLATION

The LA-2520 series actuator uses a single phase reversible motor to produce torque at the motor pinion gear. The motor torque is increased (with a corresponding decrease in speed) through two stages of spur gearing. The final output spur gear is mounted on a ball bearing supported shaft with an acme screw thread profile on one end. Rotation of this screw shaft causes a mating nut to be pulled or pushed axially. The axial nut movement is transmitted through a tube to a clevis end, providing the final output thrust. Position feedback is provided by a fine pitch spur gear train operating the feedback accessories. Each actuator feedback assembly is provided with a minimum of two limit switches for end of travel sensing.

A thrust overload mechanism is provided to prevent damage to the actuator or driven mechanism in the event the operational thrust limit of the actuator is exceeded. The screw shaft incorporates a belleville spring pack, preloaded to the rated thrust of the actuator. When an overload condition is encountered, the spring pack compresses, allowing the acme screw to move axially. This axial motion of the acme screw activates the thrust limit switch assembly, de-energizing the motor in the direction of the overload ($110 \pm 10\%$ of rated load). To remove the overload condition, the actuator may be operated in the reverse direction, or it may be manually repositioned.

A manual override mechanism is provided for positioning the actuator in the event of power failure and/or during the initial installation. Operation of the manual override mechanism requires depressing the handwheel and turning it in the required direction.

Care must be used when positioning the actuator while it is under load or during a thrust limit condition, since the thrust limiting mechanism is not operational and excess output thrust can develop in such a case.

CAUTION: Do not energize the actuator during manual positioning or attempt to engage the manual handwheel while the unit is running. Rotation of the manual handwheel by the motor could inflict personal injury.

When the motor is de-energized, the unit maintains the last position. The shaft and all gears are lubricated during manufacturing with a high quality grease, which allows the actuator to be mounted in any position. Re-lubrication is not required under normal service conditions for the life of the unit, unless the actuator is disassembled and serviced.

A drag brake may be provided in the actuator to reduce the chance of the actuator to coast upon removal of power. The drag brake is factory pre-set and requires no adjustment. The drag brake is factory adjusted to limit the coast to less than $\frac{1}{4}$ " of travel.

The actuator should be mounted with steel pins (customer supplied) through the rear and front clevises. The rear clevis is normally the stationary end. The device to be positioned must not allow the front clevis to rotate when positioning, but will allow movement in and out. Side loading can lead to excessive operating thrust requirements which could cause premature bearing failure. The device to be positioned must not require greater thrust than the thrust rating of the actuator, or the thrust limit switches will be activated.

CAUTION: The actuator is supplied with an eyebolt designed for lifting the actuator. Never use the eyebolt for lifting the actuator while there is any other equipment attached or mounted to it.

Installation

RE-CENTERING RAM TRAVEL

Turn the output clevis ccw until the clevis is 4-8 inches from the ram tube. Apply power to the actuator to cause the ram to retract. Run the actuator in this direction until the PL2 limit switch trips open, de-energizing the motor. If the unit is wired properly, once the limit switch is tripped, the motor will be prevented from further powering the actuator in this direction. Make sure that the clevis is not contacting the ram tube, as tripping the thrust limit switch will have the same effect. If the clevis contacts the tube before PL2 is tripped, remove power to the actuator and turn the output clevis CCW again, positioning the clevis several inches from the ram tube.

Re-connect the power to the actuator and drive the actuator in the retract direction once again. When PL2 trips, turn the output clevis cw until it just touches the ram tube. Back off (less than 1/2") on the output clevis to put the clevis hole in the proper plane. Apply power to energize the motor in the extend direction. Prevent the output clevis from turning and allow the actuator to fully extend until PL1 trips. The actuator is now returned to factory pre-set limits.

The limit switches may be set for actuator travel settings which are less than those set by the factory, but may not be set for those which are more than those set by the factory. Readjustment of the limit switches can be accomplished by following the directions listed under "Limit Switches."

NOTE: PL1 is at the top of the feedback assembly.

ELECTRICAL INSTALLATION

The LA-2500 series actuator is typically provided with a single phase or three phase reversible electric motor. Check the available power supply to insure that it does not vary by more than 10% of the motor voltage rating. Low AC line voltage can cause the motor to stall and high line voltage can overheat the motor, thus reducing its lifespan.

ELECTRICAL WIRING

Only persons competent by virtue of their training or experience should be allowed to install, maintain and repair the LA-2500. Work undertaken must be carried out in accordance with instructions in the manual. The user and those persons working on this equipment should be familiar with their responsibilities under any statutory provisions relating to the Health and Safety of their workplace.

Located in the electrical housing of the LA-2500 is a wiring diagram specific to the actuator. Based on this wiring diagram, connect the 4-20 mA current command input, the 4-20 loop powered transmitter (position indication), the auxiliary position switch settings (if applicable), and the condensation heater (if applicable).

A suitable switch or circuit breaker, meeting the relevant requirements of IEC60947-1 and relevant requirements of IEC60947-3, must be included in the customer's installation of the actuator and connection of power. This device must not disconnect the protective earth conductor. The switch or circuit breaker must also be mounted as close to the actuator as possible and shall be marked that it is the disconnect device for the particular actuator.

When installing 3-phase actuators, the user must fit a 3-phase, forward/reversing motor starter with loss of phase protection and a class 10 overload. The overload must be sized according to the overcurrent protection requirements of the motor. Reference the motor plate or motor data sheet for this value. Additionally the overload must be sized to ensure that it trips within 10 seconds in a fault condition.

The power and all signal cables of the actuator must be screened or contained within conduit to comply with the EMC requirements.

The protective earth (ground) connection is located on the inside of the electrical housing near the conduit entry point (green ground screw with PE symbol). Connect the protective earth using the supplied ring terminal.

***NOTE: All external circuits must be provided with insulation suitable for the rated voltage whilst considering national regulations and statutory provisions.**

To maintain the NEMA 4 and Explosion Proof rating of the actuator, insure that proper conduit connections are used.

Next, insure SWL on the control board PCB, as indicated on the wiring diagram, is set in the proper position for the input voltage required by the application.

SINGLE PHASE START UP

The single phase motor position limit switches and torque limit switches are factory wired and tested. To check proper operation, manually position the actuator to approximately mid stroke and momentarily apply single phase voltage to terminals #1 and #2 (#1 is the motor common). The actuator must extend and trip PL1. When the actuator is running in the extend direction, hand trip PL1. The actuator must stop. Apply voltage to terminals #1 and #3. The actuator must retract and once again, hand trip PL2. The actuator must stop. If the actuator runs in the wrong direction or does not stop, check the wiring terminations of the wiring diagram.



Typical Wiring Diagram

LA-2500 / AD-8140

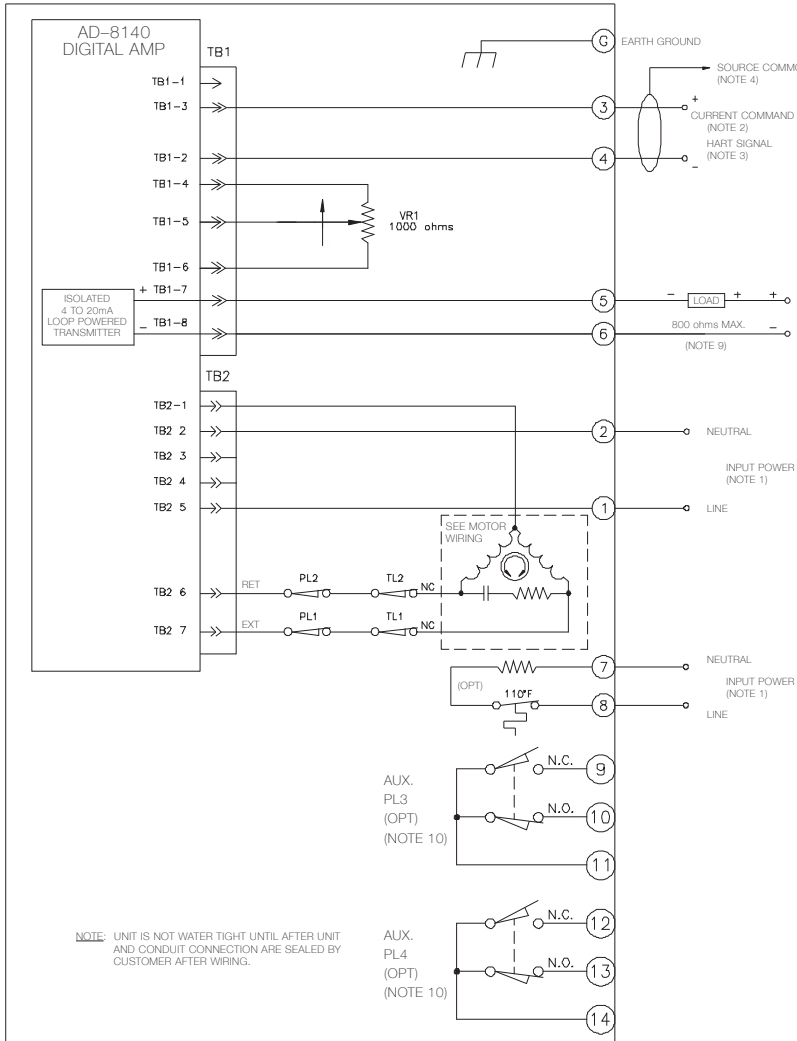

TYPICAL SWITCH CONFIGURATION

	COOLING	LIGHT-OFF	FIRING
PL1	A		
	B		
PL2	A		
	B		

RETRACTED EXTENDED

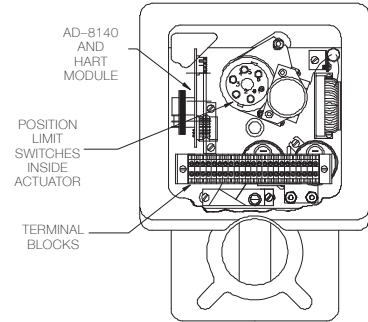

DIP SWITCH CONFIGURATIONS SW2

SWITCH	SWITCH POS	FUNCTION
1	ON (UP)	SINGLE POINT HART
	OFF (DOWN)	NOT USED
2	ON (UP)	NOT USED
	OFF (DOWN)	HART OPERATION
3	ON (UP)	LOS LOCK-IN-PLACE
	OFF (DOWN)	LOS GO TO PRESET POSITION
4	ON (UP)	DYNAMIC BRAKE ON
	OFF (DOWN)	DYNAMIC BRAKE OFF

MOTOR WIRING

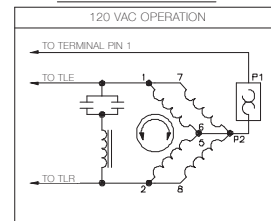

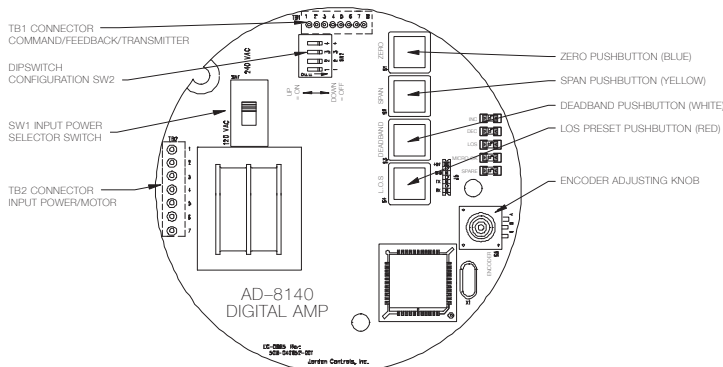

(REF: 23C-033093-001)
MOTOR SPECIFICATIONS

- VOLTAGE: 120 VAC 50/60 Hz
- HORSEPOWER: 1/2
- FULL LOAD CURRENT: 6.0 A AT 60 Hz, 7.6 A AT 50 Hz
- LOCKED ROTOR CURRENT: 15 A AT 60 Hz, 14.8 A AT 50 Hz
- FULL LOAD RPM: 1650 AT 60 Hz, 1380 AT 50 Hz
- NEMA FRAME: 58 W / SPECIAL NEMA TYPE C FRAME
- MOTOR OPERATING TEMP: 155 °C
- THERMAL OVERLOAD: INTERNAL & AUTOMATIC RESET
- INSULATION: CLASS F



Typical Wiring Diagram

- NOTES: REF: All rotation notes are viewed facing output shaft.
- WARNING! Before applying input power, check for proper selection of slide switch SW1. Operating voltage changes cannot be made simply by changing the position of the amplifier voltage switch. Motor and capacitor must be changed as well. Refer to actuator name plate for proper voltage.
- 1) INPUT POWER: For 120 VAC motor move slide switch (SW1) to the 120 VAC position. (See wiring)
For 240 VAC motor move slide switch (SW1) to the 240 VAC position. (See wiring)
For input power refer to actuator nameplate.
- 2) COMMAND: Current command input is 4–20mA applied to Terminal 3 POS (+) and Terminal 4 NEG (–)
- 3) HART SIGNAL: Feedback, setup, and diagnostics are performed using Hart communications protocol Version 6 via Terminals 3 & 4.
Hart load resistance internal to actuator.
- 4) SHIELDING: Shielded cable is required for all command and feedback signal wiring.
Terminate ground at source common.
- 5) COMMAND CALIBRATION: Apply low command to unit, normally 4mA. Depress S1 (blue) and S4 (red) until AUX LED illuminates.
Apply high command to unit, normally 20mA. Depress S2 (yellow) and S4 (red) until AUX LED illuminates.
- 6) CALIBRATION An increasing command signal will result in "EXT" of the output shaft. Set command signal to a minimum (4mA) and adjust zero to the desired position by holding down the S1 switch (blue) and rotating the adjusting knob until amplifier nulls just before the "RET" position limit "TRIPS". Set command signal to maximum (20mA) and adjust span to the desired position by holding down the S2 switch (yellow) and rotating the adjusting knob CW until amplifier nulls just before the "EXT" position limit "TRIPS". It may be necessary to repeat these steps until proper accuracy is achieved.
- REVERSE ACTING: For an increasing command resulting in "RET" set command signal to a minimum (4mA) and adjust zero to the desired position by holding down the S1 switch (blue) and rotating the adjusting knob until amplifier nulls just before the "EXT" position limit "TRIPS". Set command signal to maximum (20mA) and adjust span to the desired position by holding down the S2 switch (yellow) and rotating the adjusting knob until amplifier nulls just before the "RET" position limit "TRIPS". It may be necessary to repeat these steps until proper accuracy is achieved.
- 7) LOSS OF SIGNAL: If loss of signal go to preset is selected (SW2–3 in the OFF position), adjust preset by holding down the LOS pushbutton S4 (red) and rotating the adjusting knob to the desired position.
- 8) DEADBAND: Deadband adjusts the "sensitivity" of the servo loop. Depress and hold S3 switch (white) and turning the adjusting knob CW increases deadband. Depress.
- 9) TRANSMITTER: Input power to Terminal 5 POSITIVE (+) and 6 NEGATIVE (–) requires an external regulated power supply in the range of 12.0 (min.) to 36 VDC (max.) and a load (customer supplied) connected in series with the power supply as shown.
Transmitter signal will follow the command signal. (EX: INC command = INC feedback)
- $$\frac{\text{Power supply voltage} - 8 \text{ VDC}}{0.020\text{A max.}} = \text{load resistance}$$
- $$(0.020\text{A})^2 \times \text{load resistance} = \text{minimum WATT rating of resistor}$$
- Transmitter will produce an increasing signal as actuator moves toward SPAN, and decreasing signal as actuator moves toward ZERO.
- Apply low command to unit, normally 4mA. Depress S1 (blue) and S4 (red) until AUX LED illuminates. While holding switches rotate adjusting knob CW to increase 4mA point or CCW to decrease 4mA point. Apply high command to unit, normally 20mA. Depress S2 (yellow) and S4 (red) until AUX LED illuminates. While holding switches rotate adjusting knob CW to increase 20mA point or CCW to decrease 20mA point.
- 10) POSITION LIMITS: All position limits shown at mid-travel of the actuator.
Single-turn feedback assembly: PL1 and PL2 are wired to the N.O. contacts as shown.
AUX position limits may be used with single-turn feedback.
- 
- Multi-turn feedback assembly: PL1 and PL2 are wired to the N.C. contacts as shown.
AUX position limits NOI for use with multi-turn feedback.
- 
- 1) HEATER: Input power is required to the heater for condensation protection of the actuator.
REF. actuator nameplate for heater input voltage.
- 2) GROUND: Ground is identified by a green screw on housing of actuator. Ground is required.
- 3) INFORMATION: Refer to instruction manual for set-up instructions.



Typical Wiring Diagram

TYPICAL WIRING DIAGRAMS

LA-2520-N

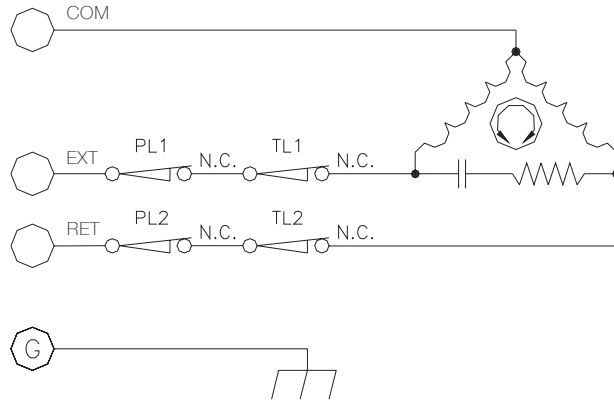

LA-2510-N SERIES ACTUATOR

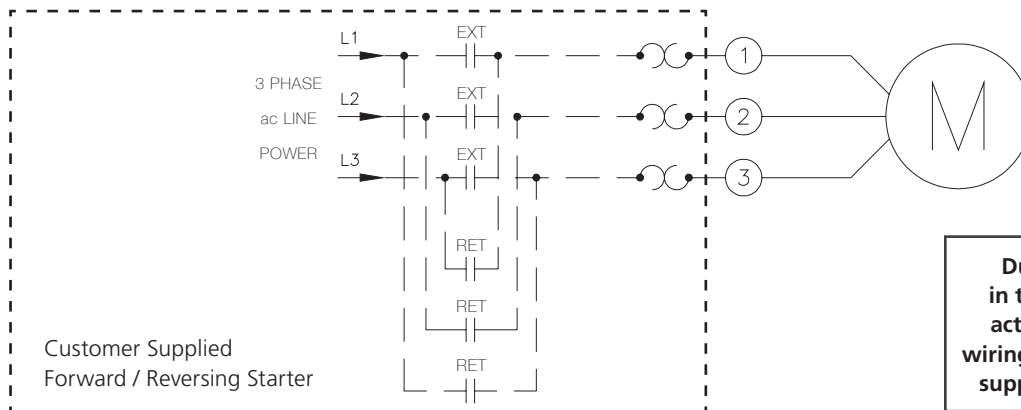

Due to wide variations in terminal numbering of actuator products, actual wiring should follow the print supplied with the actuator.

TYPICAL THREE PHASE CONTROLS SUPPLIED BY CUSTOMER

NOTE:
240 VAC Max.

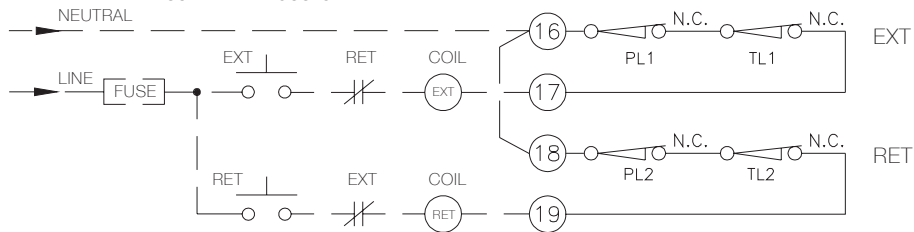

- Notes: 1. The thrust limit switches (TL1 & TL2) are factory set to trip if the thrust exceeds the actuator rating.
2. Shielded wire is required for command and position feedback signal wiring.

Start-up and Calibration

POSITION LIMIT SWITCH ADJUSTMENT WITH POTENTIOMETER

This limit switch assembly features two independently adjustable position limit switches. The setting of one switch does not affect the setting of the other. Limit switch PL1 is set to stop the actuator at the fully extended position. Limit switch PL2 is always set to stop the actuator at the fully retracted position. Each limit switch is activated by set screws. These set screws are mounted on a nut which moves longitudinally along a screw turned by the feedback gearing. Each limit switch becomes activated as the set screw trips it. To readjust the limit switches for the required actuator stroke length, the following method is recommended:

1. With no power applied to the circuits, connect an Ohm meter across the potentiometer wiper arm pin and the "zero" (retract) end of the pot.
2. Manually turn the handwheel until approximately 50 Ohms is read on the Ohm meter. This is the starting position for position limit switch adjustment.
3. Turn the front clevis CW until the clevis is approx. $\frac{1}{32}$ " from the outer support tube and the clevis hole is in the proper mounting plane.
4. Loosen the locknut and manually rotate the screw until it pushes against the limit switch, producing an audible "click." Re-tighten the locknut with moderate force to lock the screw in position.
5. Energize the motor and run the front clevis to the fully extended position. Do not allow the front clevis to rotate during this operation or the initial adjustments will change. Loosen the locknut of PL1 and manually rotate the screw until it activates the limit switch (the limit switch should be heard to activate). Re-tighten the locknut of the adjusting screw.
6. The end of travel position limit switches PL1 and PL2 are now set for the full stroke of the actuator.
7. Apply electrical power and run the actuator through its full range of motion to check for proper limit switch adjustment. Do not allow the front clevis to rotate during this operation.

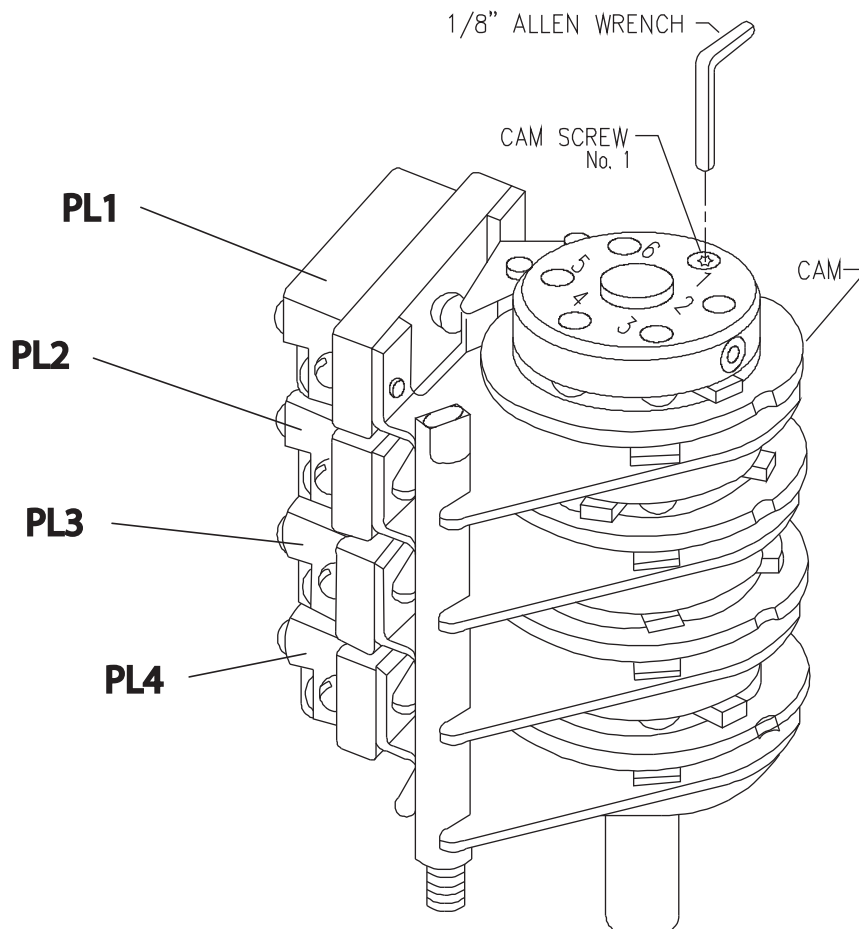

Start-up and Calibration

TWO (2), FOUR (4), OR SIX (6) OPTIONAL HEAVY DUTY LIMIT SWITCHES

This limit switch assembly features two, four, or six independently adjustable limit switches. The setting of one switch does not affect the settings of the others.

These switches are cam operated and each cam is independently adjusted for the desired position. Limit switch numbering is determined by counting from the top of the feedback assembly. The roller level of the limit switches ride on the low portion of the cam (dwell position), until the cam rotates and the high portion activates the switch. Adjustments to the switches should be set in accordance with this procedure:

1. With no power applied to the actuator, turn the manual handwheel until there is a slight gap ($1/32$ ") between the front clevis and the outer support tube.
2. Locate the set screw of PL2, which is in the hole marked "#2." Loosen this set screw a maximum of $1/2$ turn, using a long shaft $1/8$ " allen wrench. Manually rotate the cam CCW until the high part of the cam pushes against the roller lever of the limit switch, producing an audible "click." Hold the cam in this position and re-tighten the set screw to lock the cam in position.
3. Energize the actuator and drive the actuator to the fully extended position. Do not allow the front clevis to rotate during this operation or the initial adjustment will be affected. Loosen the set screw of PL1, which is in the hole marked "#1" on the end of the adaptor. Manually rotate the cam CW until the high part of the cam contacts the switch roller lever, producing an audible "click." Hold the cam in this position and re-tighten the set screw of the cam.
4. The end of travel limit switches PL1 and PL2 are now set for the full stroke of the actuator. If included, the additional limit switches may now be set for any intermediate positions within the actuator's range of movement.
5. Apply electrical power and run the actuator through its range of motion to check for proper limit switch adjustment. Do not allow the front clevis to rotate during this operation.
6. Relay contacts rated at 20 Amps, 120/240 VAC

POTENTIOMETER ALIGNMENT

If an optional single or tandem potentiometer is included with the unit, follow these instructions.

Position feedback is provided through the use of a potentiometer attached to the limit switch assembly. As the switches are driven by the actuator gearing, the potentiometer is simultaneously driven to provide position.

1. Establish if full extend or full retract is to be used for zero indication.
2. Make sure that the end of travel limit switches are correctly set.
3. Use an Ohm meter to monitor the position of the feedback potentiometer wiper to determine which end of the pot gives a low reading.
4. Loosen the set screws on the potentiometer and rotate it until 50 Ohms is read on the Ohm meter.
5. Re-tighten the set screws.

4 TO 20 mA TRANSMITTER ALIGNMENT

Before adjusting the output of the transmitter, refer to the limit switch and potentiometer alignment procedures. After the stroke length and the potentiometers are set, and the power supply and load are wired (per the installation wiring print), move the actuator to the fully retracted position. Adjust the Elevation trim pot to achieve 4.0 mA output. Run the actuator to the full extend position. Adjust the Range trim pot on the transmitter to 20.0 mA output. Repeat until interaction no longer occurs. For an increasing feedback signal with the actuator retracting, interchange blue and yellow leads. Re-calibration of the pot and transmitter may be necessary.

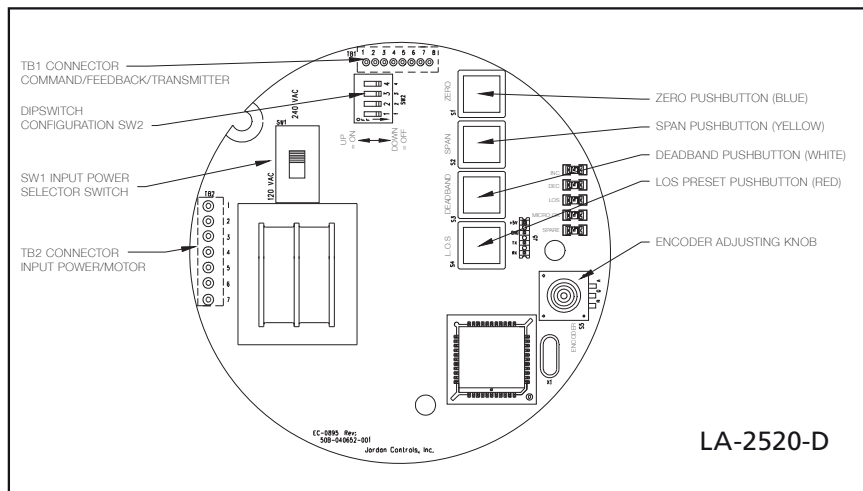

LA-2520-D Internal Amplifier Start-up and Calibration

Refer to diagram on previous page.

- 1) **Power.** Before applying AC power to TB2 set slide switch to the correct voltage (120/240 VAC). See input signal. Ensure dip switch setting meets installation requirements.

DIP SWITCH CONFIGURATIONS SW2		
Switch	Switch POS	Function
1	On (Up)	Current Command
	Off (Down)	0–5V/0–10V Voltage Command
2	On (Up)	0–5V Voltage Command
	Off (Down)	Current/0–10V Voltage Command
3	On (Up)	LOS Lock-In-Place
	Off (Down)	LOS Prest Position
4	On (Up)	Dynamic Brake On
	Off (Down)	Dynamic Brake Off

- 2) **Command Calibration.** This procedure calibrates the minimum and maximum command to the unit.
 - A) Set command signal to low level, normally 4 mA.
 - B) For AD-8140 amplifiers, depress ZERO pushbutton (S1) and LOS pushbutton (S4) until the SPARE LED illuminates. For AD-8240 amplifiers, depress ZERO pushbutton (S1) and LOS pushbutton (S4) until the LOS LED flashes.
 - C) Set command signal to high level, normally 20 mA.
 - D) For AD-8140 amplifiers, depress SPAN pushbutton (S2) and LOS pushbutton (S4) until the SPARE LED illuminates. For AD-8240 amplifiers, depress SPAN pushbutton (S2) and LOS pushbutton (S4) until the LOS LED flashes.
- 3) **Auto/Manual (Option).** If the unit has the Auto/ Manual switch option, place it in the auto position.
- 4) **Setpoints.** These are the end of travel extremes corresponding to the actuator output shaft positions for low (4 mA) and high (20 mA) command signal levels. They are set by the ZERO and SPAN pushbuttons and adjusting knob. All settings require the holding of a push button and the turning of the adjusting knob.
 - A) Set the command signal to lowest level, normally 4 mA.
 - B) Adjust LO setpoint (ZERO) by holding ZERO push button (S1) and turning adjusting knob to move actuator output shaft to desired position. Turn the adjusting knob CW to extend the output shaft for linear actuators, or rotate the output shaft CW for rotary actuators. Turn the adjusting knob CCW to retract the output shaft for linear actuators, or rotate the output shaft CCW for rotary actuators. Release button.

- C) Set the command signal to highest level, normally 20 mA.
 - D) Adjust HI setpoint (SPAN) by holding SPAN push button (S2) and turning adjusting knob to move actuator output shaft to desired position. Turn the adjusting knob CW to extend the output shaft for linear actuators, or rotate the output shaft CW for rotary actuators. Turn the adjusting knob CCW to retract the output shaft for linear actuators, or rotate the output shaft CCW for rotary actuators. Release button.
- 5) **Transmitter.** This adjustment sets the endpoints of the 4-20 mA transmitter to account for variations in accuracy of the input command.
 - A) Set command signal to low level, normally 4 mA.
 - B) For AD-8140 amplifiers, depress ZERO pushbutton (S1) and LOS pushbutton (S4) until the SPARE LED illuminates. For AD-8240 amplifiers, depress ZERO pushbutton (S1) and LOS pushbutton (S4) until the LOS LED flashes. While depressing pushbuttons, turn adjusting knob CW to increase the 4 mA point, or CCW to decrease the 4 mA point.
 - C) Set command signal to high level, normally 20 mA.
 - D) For AD-8140 amplifiers, depress SPAN pushbutton (S2) and LOS pushbutton (S4) until the SPARE LED illuminates. For AD-8240 amplifiers, depress SPAN pushbutton (S2) and LOS pushbutton (S4) until the LOS LED flashes. While depressing pushbuttons, turn adjusting knob CW to increase the 20 mA point, or CCW to decrease the 20 mA point.



LA-2520-D Internal Amplifier Start-up and Calibration

- 6) **Deadband.** This adjustment establishes the actuator servo sensitivity. It is factory set at 1% and should not be field adjusted. If the actuator begins to oscillate (Green and Yellow LEDs turn on and off rapidly), decrease the sensitivity by holding deadband push button (S3) and turning adjusting knob CW until oscillation stops. Release button.
- 7) **Loss of Signal Preset.** This adjustment establishes the position to which the actuator will travel upon a loss of command signal condition. To activate this setting, SW3 must be OFF. Adjust the setting by holding the LOS push button (S4) and turning the adjusting knob to set the preset position. Turn the adjusting knob CW to extend the output shaft for linear actuators, or rotate the output shaft CW for rotary actuators. Turn the adjusting knob CCW to retract the output shaft for linear actuators, or rotate the output shaft CCW for rotary actuators.
- 8) **AC incremental control (manual control).** A break in command signal is required when using AC Incremental Control. For actuator ram extension, apply 120 to 240 VAC to the white wire (L) and the black wire (N) until the desired extend position is reached. For auto control, there must be no voltage to the red, black and white wires. Refer to typical wiring diagram shown on p10.
- 9) **Verify all settings** by running the actuator through its travel range several times.

HART Calibration

CALIBRATION AND START-UP

The unit can be calibrated remotely using the handheld calibrator connected to the HART network.

1. Manually adjust the actuator to the closed position.
2. Mount the actuator. If it is necessary to align the clevis with the linkage, move the actuator toward the open position.
3. Connect power to the actuator.
4. Connect the HART handheld programmer across terminals 3 and 4 of the actuator. Turn on programmer. After the programmer finishes searching for HART devices, select the actuator.
5. Using the handheld programmer, disable the write protect by selecting the 'Enable Configuration Update' and if required, select 'Restore Factory Set Up'.
6. Apply the 4 mA input demand signal to the actuator and send the HART command: 'Set 4 mA Command Current Reference'.
7. Apply the 20 mA input demand signal applied to the actuator and send the HART command: 'Set 20 mA Command Current Reference'.
8. Move the actuator to the required closed position and then set this as the 'Lower Range'. Then, move the actuator to the required open position and then set this as the 'Upper Range'.
9. Set the 'Fixed Current Mode' to 4 mA. Measure the loop powered transmitter current and write this value to the actuator via the 'Adjust Transmitter Current Zero' command. Repeat this step until the measured output current is 4 mA.
10. Set the 'Fixed Current Mode' to 20 mA. Measure the loop powered transmitter current and write this value to the actuator via the 'Adjust Transmitter Current Span' command. Repeat this step until the measured output current is 20 mA.
11. Set the 'Fixed Current Mode' to 0 mA. The transmitter output current will now correspond to the actuator's position.
12. Deselect the 'Enable Configuration Update' mode.

HART Setup Information

HART Command Set - Universal Commands

COMMAND		DATA IN COMMAND		DATA IN REPLY	
Nbr.	Function	Byte	Function	Byte	Function
0	Read Unique Identifier		None	0 1 2 3 4 5 6 7 8 9-11 12 13 14-15 16	"254" (expansion) manufacturer identification code manufacturer's device type code number of preambles universal command revision transmitter specific command revision software revision hardware revision device function flags device ID number number of preambles max number of device variables configuration change counter extended field device status
1	Read Primary Variable		None	0 1-4	Position Units Code Position (Float)
2	Read Current and Percent of Range		None	0-3 4-7	Current in mA (Float) Percent of Range (Float)
3	Read Current and Dynamic Variables		None	0-3 4 5-8 9 10-13 14-18	Current in mA (Float) Position Units Code Position (Float) Setpoint Units Code Setpoint (Float) Unused
6	Write Polling Address	0 1	Polling Address Loop Current Mode	0 1	Polling Address Loop Current Mode
11	Read Unique Identifier Associated with Tag	0-5	Tag (Packed ASCII)	0-16	Same Response as Command 0 Read Unique Identifier
12	Read Message		None	0-23	Message (Packed ASCII)
13	Read Tag, Descriptor, Date		None	0-5 6-17 18-20	Tag (Packed ASCII) Descriptor (Packed ASCII) Date (Date)
14	Read PV Sensor Information		None	0-2 3 4-7 8-11 12-15	Unused Endpoints units code (Byte) Endpoint 1 (Float) Endpoint 0 (Float) Unused
15	Read Output Information		None	0 1 2 3-6 7-10 11-14 15 16-17	Unused Transfer Function Code Span and Zero units code Span (Float) Zero (Float) Unused (Float) Write-Protect Code Unused
16	Read Final Assembly Number		None	0-2	Final Assembly Number
17	Write Message	0-23	Message (Packed ASCII)	0-23	Message (Packed ASCII)
18	Write Tag, Descriptor, Date	0-5 6-17 18-20	Tag (Packed ASCII) Descriptor (Packed ASCII) Date (Date)	0-5 6-17 18-20	Tag (Packed ASCII) Descriptor (Packed ASCII) Date (Date)
19	Write Final Assembly Number	0-2	Final Assembly Number	0-2	Final Assembly Number



HART Setup Information

HART Command Set - Common Practice Commands

COMMAND		DATA IN COMMAND		DATA IN REPLY	
Nbr.	Function	Byte	Function	Byte	Function
36	Set Upper Range		None		None
37	Set Lower Range		None		None
38	Reset Configuration Changed Flag		None		None
41	Perform Self Test		None		None
48	Read additional transmitter status		None	0-5	Additional status
59	Write number of response preambles	0	Number of response preambles	0	Number of response preambles

HART Command Set - Device Specific Commands

COMMAND		DATA IN COMMAND		DATA IN REPLY	
Nbr.	Function	Byte	Function	Byte	Function
128	Read materials		None	0 1 2 3 4-6 7	Actuator series Force range Voltage input Stroke range Unused Factory service option
133	Set 4mA Command Current ref		None		None
134	Set 20mA Command Current ref		None		None
136	Restore factory setup		None		None
167	Enable configuration update	0	Enable	0	Enable
190	Transmitter Fixed Current Level	0-3	Fixed Current Level (mA)	0-3	Actual Current Level (mA)
191	Adjust Transmitter Current Zero	0-3	Measured Current Level (mA)	0-3	Actual Current Level (mA)
192	Adjust Transmitter Current Span	0-3	Measured Current Level (mA)	0-3	Actual Current Level (mA)

Troubleshooting Guide

TROUBLE	POSSIBLE CAUSE	REMEDY
Motor won't operate	a. No power to actuator	a. Check source, fuses, wiring
	b. Motor overheated and internal thermal switch tripped (single phase AC motors only)	b. Let motor cool and determine why overheating occurred (such as, excessive duty cycle or ambient temperature)
	c. Motor defective	c. Replace motor and determine cause of failure
	d. Both end of travel position limit switches open or one open and one defective	d. Adjust switch settings or replace defective switch
	e. Actuator ram stalled (mechanically jammed)	e. Check drive load for mechanical jam and correct cause
	f. Defective motor run capacitor (single phase AC motors only)	f. Replace capacitor
	g. Load exceeds actuator thrust rating	g. Reduce load or replace actuator with one with appropriate thrust rating
	h. Power applied to extend & retract at same time	h. Correct power input problem
	i. Amplifier defective	i. Replace amplifier
	j. Amplifier is in Loss of Signal	j. Check command signal to verify signal greater than 3.8 mA is present
	k. Amplifier deadband is too wide	k. Reduce deadband setting
Ram positions in wrong direction for extend and retract input power	a. Wiring to actuator incorrect	a. Correct field wiring
	b. Wiring from motor to terminals or switches is reversed	b. Correct internal actuator wiring
Motor hums, but does not run	a. Power applied to extend & retract at the same time	a. Correct power input problem
	b. Damaged power gearing	b. Repair gearing
	c. Defective motor run capacitor (single phase AC motors only)	c. Replace capacitor
	d. Damaged servo amplifier	d. Replace servo amplifier
Motor runs, but ram does not move	a. Defective power gearing	a. Repair gearing
	b. Screw drive nut stripped or pulled out of tube	b. Repair or replace screw drive nut
Motor does not shut off at limit switch	a. Switch wired wrong or is defective	a. Correct wiring or replace switch
	b. Switches are not aligned	b. Align switches

Troubleshooting Guide

TROUBLE	POSSIBLE CAUSE	REMEDY
Thrust limit switch operation	a. Thrust limit switch not properly wired to control circuit	a. Correct wiring per diagram
	b. Thrust limit switch collars loose or not properly adjusted	b. Adjust and tighten collars as required
	c. Thrust limit switch defective	c. Replace
	d. Thrust limit switch bent and binding	d. Replace shaft
	e. Thrust limit switch mounting or bushing is bent or damaged	e. Replace as required
	f. Thrust limit switch mounting block not aligned or secured	f. Align and secure blocks as required
	g. The actuator is overloaded	g. Remove overload
	a. Power not applied for other direction	a. Correct power problem
	b. Power always applied to one direction and electrically stalls when applied for opposite direction	b. Correct power problem
	c. Open limit switch for other direction	c. Adjust or replace limit switch as required
	d. Actuator is in thrust overload	d. Determine obstruction and correct
	e. Motor has an open winding	e. Replace motor
	f. Motor and feedback potentiometer are out of phase	f. Reverse potentiometer end leads
	g. Amplifier is defective	g. Replace amplifier
Poor response to command signal changes	a. Amplifier deadband is too wide	a. Reduce deadband setting
	b. Amplifier is defective	b. Replace amplifier
	c. Excessive noise on command signal	c. Reduce noise. Also ensure that command signal wiring is shielded with shield grounded at source common only
Actuator oscillates at setpoint	a. Amplifier deadband is too narrow	a. Increase deadband setting
	b. Amplifier is defective	b. Replace amplifier
	c. Excessive noise on command signal	c. Reduce noise. Also ensure that command signal wiring is shielded with shield grounded at source common only
Pot feedback signal not always present during actuator ram movement	a. Pot not aligned with end of travel extremes and is being driven through its dead region	a. Align pot to range of actuator
	b. Pot signal is erratic or nonexistent	b. Replace pot
Pot signal does not change as actuator operates	a. Defective pot	a. Replace pot
	b. Feedback gear not turning pot shaft	b. Check gearing engagement and set screw in gear hub
Pot signal is reversed for output ram direction	a. Pot is wired wrong	a. Reverse wiring from ends of pot at actuator terminal block
Water droplets inside of actuator	a. Condensation caused by temperature variations and humidity	a. Add heater and thermostat circuit and ensure that existing circuit is continuously energized. Check conduit entry and seal to prevent water from entering via the conduit
	b. Water entering actuator	b. Ensure rear cover gasket is in place and replace if defective. Also ensure all cover bolts are in place and tightened. Check conduit entry and seal to prevent water from entering via the conduit. Order optional bellows kit if needed

Note: For actuators controlled by servo-amplifiers, refer to that servo-amplifier's instruction manual for additional troubleshooting information.

Repair and Maintenance

HOUSING SEPARATION

1. Loosen the 12 cover screws and remove the feedback cover assembly.
2. Locate all motor wires. Record the wire numbers and termination points. Disconnect the motor wires.
3. Hold the handcrank shaft coupling and rotate the front clevis (manually) ccw until the clevis roll pin is at least ½ inch from the end of the outer support tube.
4. Using a ¼ inch diameter drift punch and hammer, remove the clevis roll pin. Pull the front clevis out of the inner tube. Check the pin holes in the tube for burrs, and remove as necessary. Check the o ring on the clevis and replace if damaged. Check the clevis for wear or cracks, and replace if necessary.
5. Remove the six socket head cap screws and lockwashers, which hold the housings together.
6. A. Using a rubber- or plastic-tipped mallet, separate the housings. There may be some resistance, as the housing are located to each other with dowel pins. **DO NOT use screwdrivers or other prying devices to separate the housings to avoid damaging machined surfaces.**
B. While guiding the motor wires and noting the locations of the power idle gear and the feedback gear assemblies, slowly separate the housings.
C. When the housing are sufficiently separated, remove the gear assemblies. Clean and inspect them.
D. Completely separate the housings into two sub-assemblies.
7. To re-assemble the housing, see “Actuator Housing Re-Assembly.”

MOTOR REPLACEMENT

1. Perform steps 1 through 6 of the Housing Separation procedure.
2. Remove the motor pinion gear retaining ring.
3. Slide the gear off of the motor shaft.
4. Remove the woodruff key from the motor shaft.
5. Remove the four bolts which hold the motor housing to the casting. **The motor outer shell is a tight fit to the casting. Take care not to damage machined surfaces.**
6. Removal of the motor can cause substantial damage, including the destruction of the motor. Ensure that removal is necessary before proceeding.
7. The motor shell can be removed from the housing by tapping it with a mallet. Or, the person repairing the unit may devise a clamp that fits around the motor with two long jack screws that push against the housing.
8. After the entire motor has been removed, clean the bearing bore hole and the outer machined surface for the motor shell.
9. A. Prior to installing the new motor, ensure that the housing bore for the motor shaft is clean.
B. Coat the machined surface of the housing, used to locate the motor shell, with Dow Corning High Vacuum Grease-Silicone Lubricant.
C. While guiding the motor wires through the housing and locating the motor bolt holes, mount the motor. A rubber or plastic mallet should be used to seat the motor. **DO NOT use the motor bolts to seat the motor. This may cause excessive pressure to, and the cracking of, the motor end casting.**
D. After properly seating the motor, tighten the four motor bolts evenly.
E. To check for proper positioning, manually spin the motor shaft. It must spin freely without dragging on the actuator housing.
10. Install the woodruff key and slide the motor pinion gear onto the motor shaft. **DO NOT FORCE the gear onto the shaft. This will cause it to become out-of-round.** Install the retaining ring.



Repair and Maintenance

SCREW SHAFT TRAVEL NUT REPLACEMENT

1. Perform steps 1 through 6 of the Housing Separation procedure.
2. Hold the screw gear to prevent the screw from rotating. Rotate the inner tube cw until the end of the tube almost contacts the screw gear.
3. Looking into the end of the inner tube, use a straight tip external retaining ring pliers to remove the retaining ring from the end of the screw shaft.
4. Remove the inner tube and travel nut from the screw shaft by rotating the tube ccw. The screw guide may fall out of the tube at some point during this removal. If it does not, remove it after the tube and nut have been removed from the screw.
5. A. Referring to the inner tube assembly, remove the retaining ring and the spacer.
B. Pull the nut out of the tube.
6. Being sure that the spacer and the key are in place, locate the key slot of the nut with the key, and push the nut into place.
7. Insert the outer spacer and the retaining ring.
8. Clean the screw shaft and apply a light coating of screw shaft grease EP-50. **DO NOT substitute.**
9. Install the inner tube assembly on the screw shaft by rotating the tube cw, threading the nut onto the screw. Continue threading until the end of the tube just touches the screw gear.
10. Install the screw guide and the retaining ring.
11. Rotate the tube ccw until the end of the tube is about two inches from the face of the screw gear.

TUBE SCRAPER, SEAL OR BEARING REPLACEMENT

1. Perform steps 1 through 6 of the Housing Separation procedure.
2. Referring to the outer tube assembly, remove the retaining ring, the scraper, the adaptor seal, the Teflon seals, and the bearings.
3. Inspect all parts, and replace any as necessary. Upon re-assembly, insert the parts into the tube in the reverse order of removal.

SCREW SHAFT OR SCREW SHAFT BEARING REPLACEMENT

1. Perform steps 1 through 4 of the Screw Shaft Travel Nut Replacement procedure.
2. Remove the four cap screws and lockwashers which hold the rear clevis to the housing. Remove the clevis and the clevis gasket.
3. Hold the screw gear to prevent rotation, and remove the hex head screw and washer.
4. Remove the screw shaft, bearings, and belleville washers from the housing.
5. Clean the bearing bore completely. Lubricate the wall of the bore lightly with Amoco Premium Grease No. 2.
6. Slide one bearing into the bottom of the bore. It must slide freely.
7. Lubricate the bearing end of the screw shaft and slide it into the housing. Push the bearing to the bottom of the bore.
8. Properly stack and insert the number of belleville washers and spacer needed (if they are used here). The number will depend upon the thrust requirement.
9. Insert the outer bearing.
10. Apply service-removable loctite to the threads of the hex head screw, and install with a belleville washer. Hold the screw gear to prevent it from rotating, and tighten the hex head screw until the belleville washer is fully collapsed.
11. Perform steps 8 to 11 of the Screw Shaft Travel Nut Replacement procedure.

Repair and Maintenance

GEAR REPLACEMENT AND COMPLETE LIMIT SWITCH ASSY REPLACEMENT

1. Perform steps 1 through 6 of the Housing Separation procedure.
2. Remove and inspect the power idler gear assembly and the feedback gear assemblies.
3. Check all bushings for wear and replace if needed.
4. Remove the gear from the limit switch assembly.
 - A. Ten Turn Assembly
 - Remove the three truss head screws which hold the limit switch frame to the housing.
 - Remove the limit switch assembly.
 - Transfer the wires (one at a time to ensure proper wiring) from the original assembly to the new one.
 - Install the new assembly retaining with three truss head screws.
 - Place the gear on the shaft and tighten. Then set the screws and rotate the gear slowly, until the lower limit switch (the switch closest to the housing) just trips.
 - B. Cam Operated Switch Assembly
 - Remove the woodruff key from the shaft.
 - Remove the switch plate anchor shaft.
 - Remove the entire switch assembly.
 - Transfer the wires (one at a time to ensure proper wiring) to the new switch assembly.
 - Re-install in the reverse order of the disassembly procedure.

LIMIT SWITCH REPLACEMENT

1. Ten Turn Feedback

The switches are mounted to the frame with slot head screws. Remove and replace the switch, then un-solder the wires from the original switch. Transfer and solder the wires to the new switch. Check the switch adjustments.
2. Cam Switch Feedback

The switches are mounted to the switch plates with slot head screws. Remove and replace the switch. Transfer the wires (one at a time to ensure proper wiring) from the original switch to the new one.

POTENTIOMETER REPLACEMENT

1. Ten Turn Feedback
 - A. Prior to removing the potentiometer, manually position the actuator to the full retract position. The lower switch on the feedback assembly should be just tripping.
 - B. Loosen the set screw located closest to the potentiometer in the aluminum multi-turn screw.
 - C. Loosen the pot body nut and remove the potentiometer.
 - D. Turn the shaft of the new potentiometer fully cw, then back it off 1/2 turn ccw.
 - E. Insert the new potentiometer into the frame with the body nut and lockwasher in place.
 - F. Tighten the pot body nut to ensure that the potentiometer is seated on the frame.
 - G. Tighten the set screw for the potentiometer shaft.
 - H. Loosen the pot body nut about 1/2 turn, or until the pot body is just loose enough to rotate.
 - I. Rotate the actuator manual over-ride shaft ccw until the switch adjust screw no longer touches the lower switch.
 - J. Rotate the manual over-ride shaft cw until the lower limit switch is just tripped.
 - K. Use a Ohm meter to measure the resistance from the pot wiper terminal to the CW terminal on the post. Rotate the pot body until a measurement of 50 Ohms is obtained (for a 1000 Ohm pot, or 5% of the total resistance for other than 1000 Ohm pots). Tighten the pot body nut. If all of the previous steps have been followed correctly, the post body should need to be moved only one turn or less.
 - L. With the lower limit switch just tripped and the pot set at 50 Ohms (or 5%), the actuator front clevis should be at full retract. If it is not, rotate the front clevis cw until the clevis just touches the outer support tube, then rotate the clevis slightly ccw until the clevis pin hole is in the desired plane. The gap from the end of the tube to the clevis should be no greater than 1/16 inch.



Repair and Maintenance

- M. Electrically or manually position the actuator to the full extend position. Monitor the feedback potentiometer with an Ohm meter. Do not allow the front clevis to rotate. The potentiometer resistance from the pot wiper terminal to its cw terminal should increase as the actuator extends. At full extend position, the upper limit switch will trip. The pot resistance from the wiper terminal to the ccw terminal should be 50 Ohms or more for a 1000 Ohm pot (5% or more for other values).
- 2. Cam Operated Limit Switch
 - A. Remove the two screws which hold the pot mounting plate to the limit switch assembly.
 - B. Remove the pot rod meeting plate assembly from the switch assembly.
 - C. Remove the gear from the pot shaft.
 - D. Remove the pot body nut and remove the pot from the plate.
 - E. Cut the shaft of the new potentiometer to the same length as the original shaft, install the new potentiometer on the plate, and place the gear in their proper position on the shaft.
 - F. Mount the assembly on the limit switch holder.
 - G. Transfer the wires (one at a time to ensure proper wiring) from the old potentiometer to the new one.
 - H. Calibrate per the instructions listed under "Potentiometer Alignment."

THRUST LIMIT SWITCH REPLACEMENT

1. Remove the terminal bracket assembly.
2. Remove the three screws which hold the thrust limit switch assembly to the housing, and pull the assembly out of the housing.
3. Remove and replace the thrust limit switch. **DO NOT loosen the thrust limit switch adjustment collars.**
4. Re-install the thrust limit assembly and the terminal bracket assembly.

ACTUATOR HOUSING RE-ASSEMBLY

1. Lubricate all bronze bushings with a few drops of SAE 10, 20, or 30 weight non-detergent oil.
2. Lubricate the tubes with Amoco Amolith Premium Grease No. 2.
3. Place the power idler gear in position on the motor side of the housing.
4. Place both feedback gears in position on the motor side of the housing.
5. Lubricate all gears with Amoco Amolith Premium Grease No. 2.
6. Place a new gasket on the feedback housing.
7. Guide the housings together. **DO NOT allow motor wires to be pinched. Make sure that the gear shafts go into the bushings.** It may be necessary to wiggle limit switch shaft gear and the manual handwheel shaft gear in order to mesh the teeth.
8. Insert the housing bolts and lockwashers.
9. Insert the front clevis with the o ring on it. Line up the pin hole while inserting.
10. Reconnect motor wires and insure they are properly phased for instructions listed under "Start Up" in the Electrical Installation section of this manual.
11. Align per instructions under "Subassembly Alignments".

Parts Identification

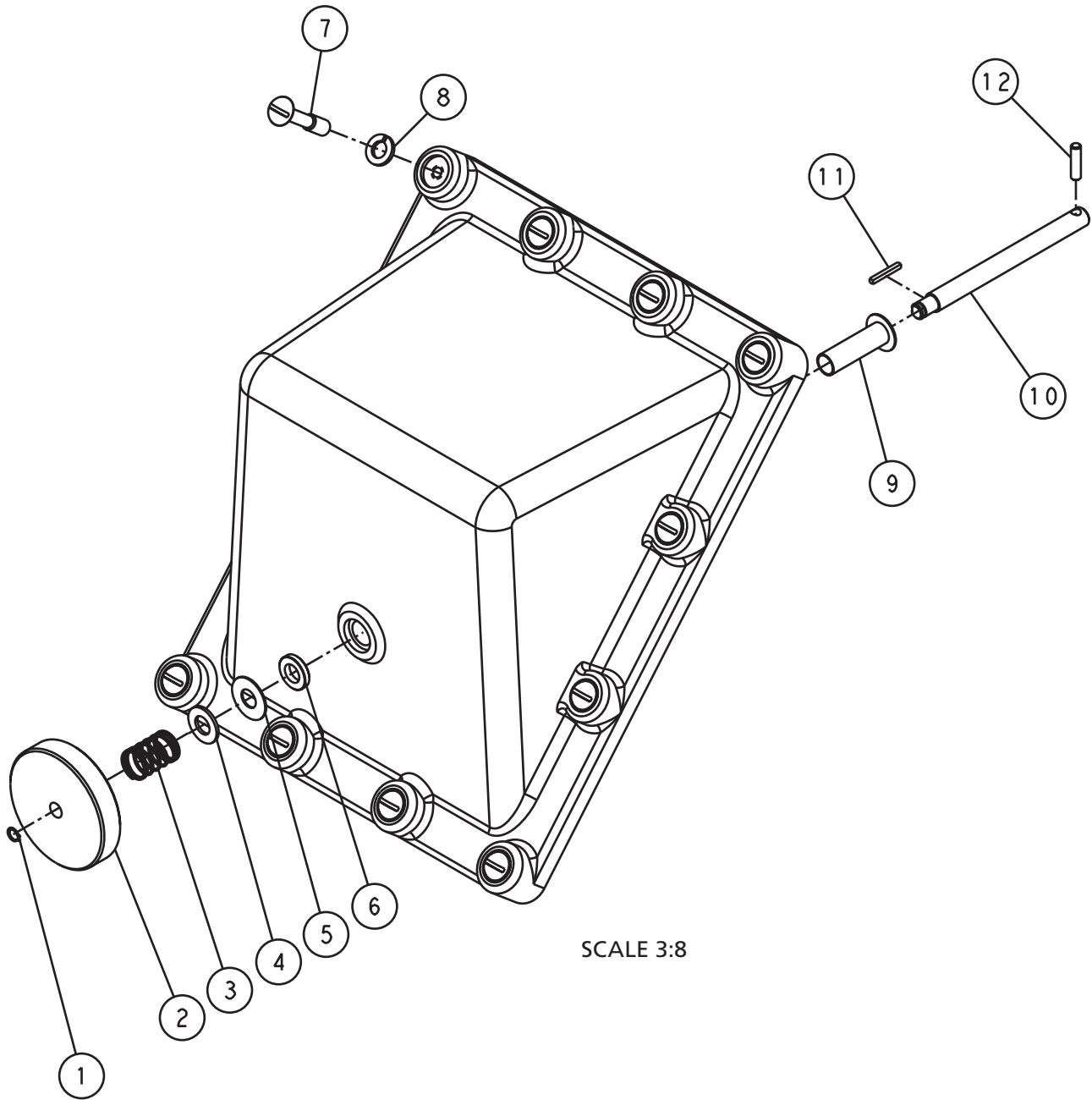

SCALE 3:8

ITEM NO.	DESCRIPTION	PART NUMBER	QTY.
1	Retaining Ring	58B-014183-031	1
2	Handcrank	61A-024164-001	1
3	Spring	20A-012308-001	1
4	Thrust Washer (Steel)	56B-004107-008	1
5	Thrust Washer (Bronze)	56B-004107-007	1
6	Seal	19B-003815-030	1
7	Captive Screw	54A-033354-001	12
8	Lockwasher	56A-015220-002	12
9	Bushing	18B-SP1988-035	1
10	Handcrank Shaft	62A-024163-002	1
11	Key	61B-010954-110	1
12	Dowel Pin	57A-015206-075	1

Parts Identification

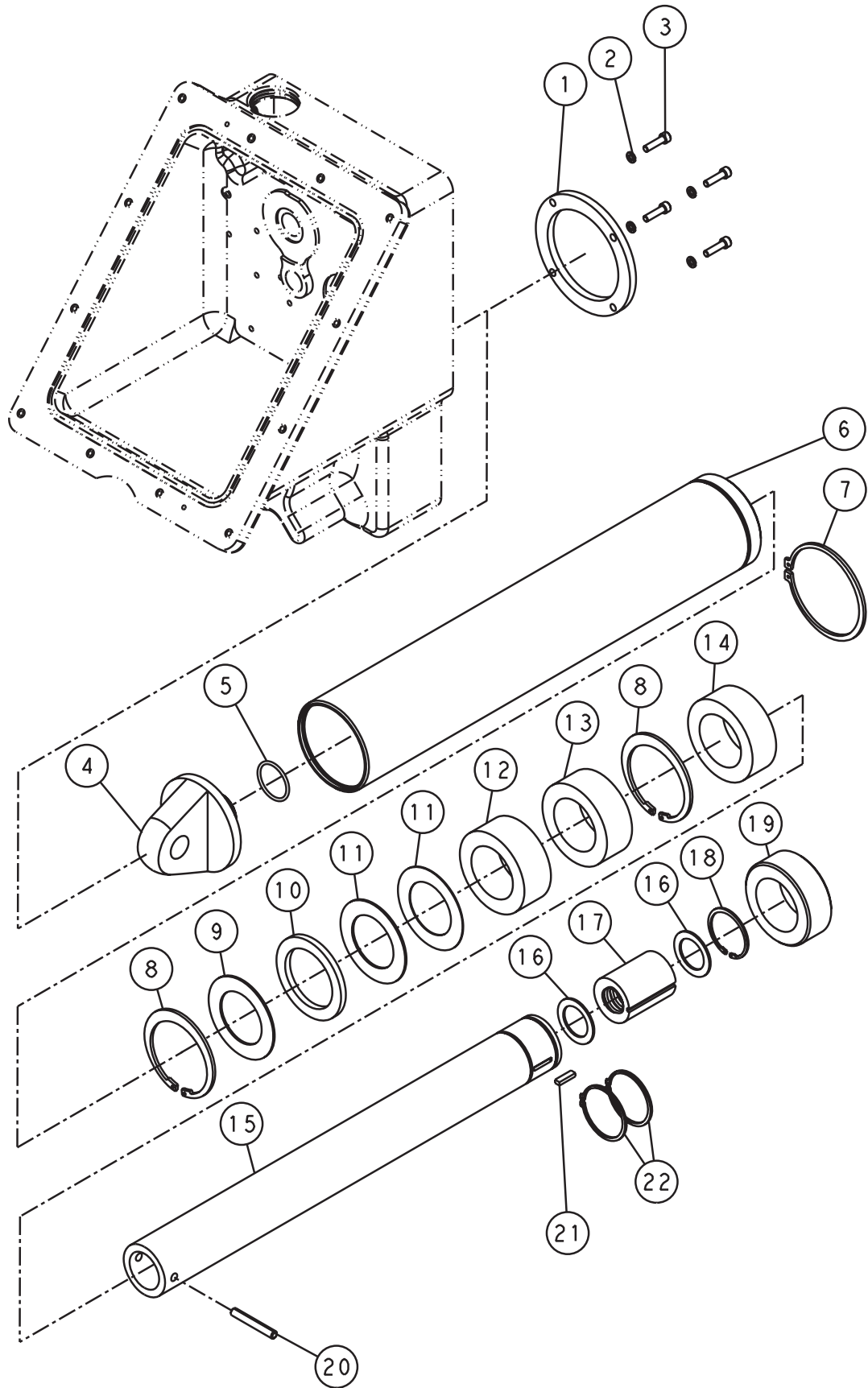

Parts Identification

ITEM NO.	DESCRIPTION	PART NUMBER	QTY.
1	Retaining; Outer Tube	61A-024170-001	1
2	Lockwasher	56A-015211-001	4
3	Bolt 1/4"-20 X 3/4"	54A-015060-075	4
4	Front Clevis; .88" Pin Hole	60A-015928-001	1
	Front Clevis; .75" Pin Hole	60A-015928-003	1
5	Front Clevis O-Ring	74B-010957-024	1
6	Outer Tube 6"	61B-030906-001	1
	Outer Tube 12" A Option	61B-030906-002	1
	Outer Tube 12" B Option	61B-030906-003	1
	Outer Tube 12" C & D Options	61B-030906-004	1
	Outer Tube 18"	61B-030906-005	1
	Outer Tube 24"	61B-030906-006	1
7	Ret. Ring; Outer Tube	58B-014183-300	1
8	Ret. Ring	58B-014184-275	2
9	Tube Scraper	61A-010846-001	1
10	Adapter Seal	61A-010845-001	1
11	Tube Seal	19A-010802-001	2
12	Tube Bearing	14A-009919-001	1
13	Tube Bearing	14A-028585-001	1
14	Buffer Ring	61A-011090-001	1, 2 or 3
15	Inner Tube 6"	61B-030905-001	1
	Inner Tube 12" A Option	61B-030905-002	1
	Inner Tube 12" B Option	61B-030905-003	1
	Inner Tube 12" C & D Option	61B-030905-004	1
	Inner Tube 18"	61B-030905-005	1
	Inner Tube 24"	61B-030905-006	1
16	Spacer; Drive Nut	74A-015926-001	2
17	Drive Nut	61A-013004-001	1
18	Ret. Ring	58B-014184-150	1
19	Tube Bearing	61A-009918-001	1
20	Roll Pin	57A-015215-175	1
21	Key	61A-012228-001	1
22	Ret. Ring	58B-014183-175	2



Parts Identification

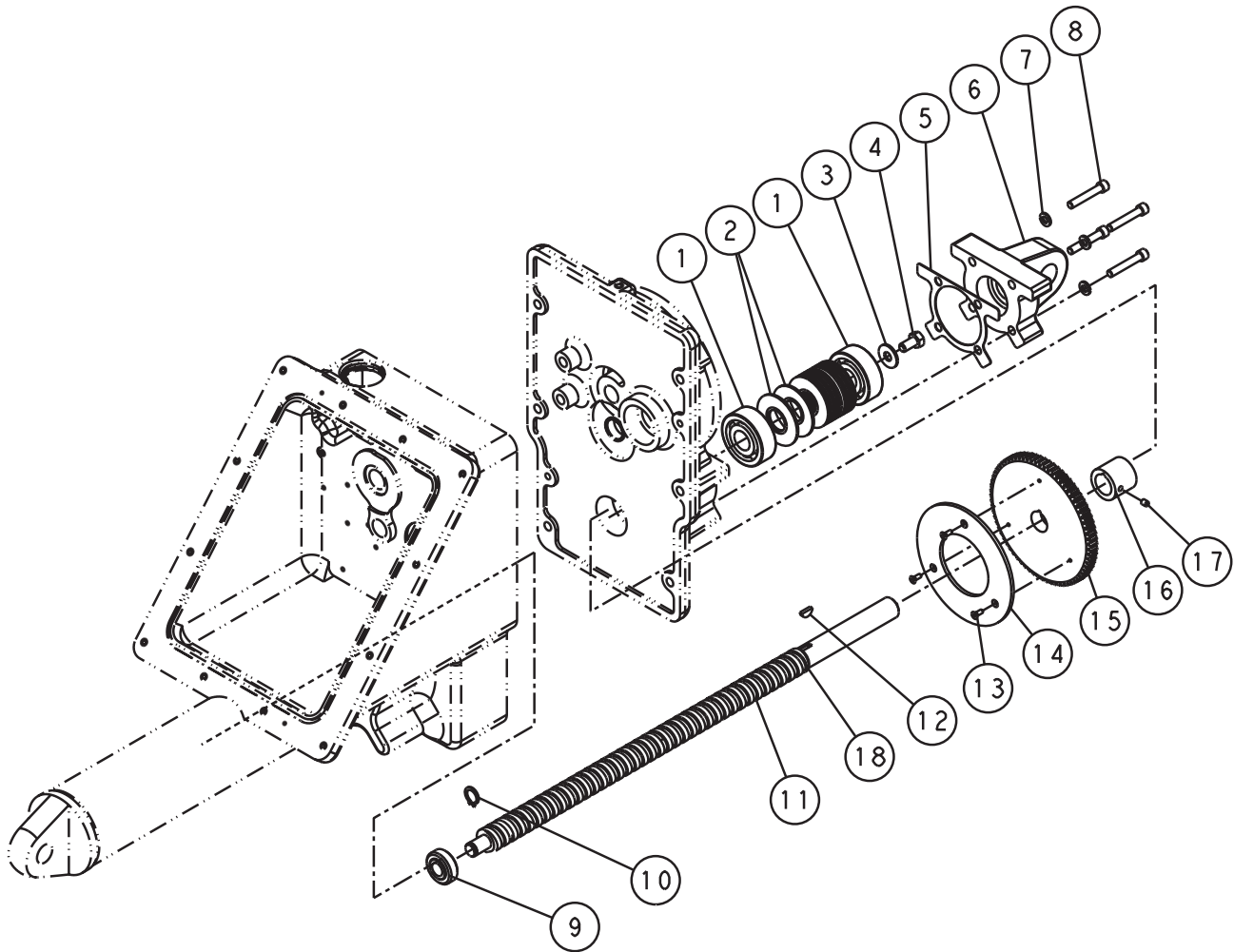

ITEM NO.	DESCRIPTION	PART NUMBER	QTY.
1	Bearing	17B-003813-033	2
2	Belleville Washers/Spacer	Consult Factory	N/A
3	Belleville Washer	56B-010462-021	1
4	Bolt 3/8"-16 x 1"	54A-015081-100	1
5	Gasket; Rear Clevis	13D-009727-004	1
6	Rear Clevis; .88 Dia. Hole	61A-030917-002	1
	Rear Clevis; .75 Dia. Hole	61A-030917-003	1
7	Lockwasher	56A-015211-001	4
8	Bolt 1/4"-20 x 1 1/2"	54A-015060-150	4
9	Screw Guide	14A-016140-001	1
10	Retaining Ring	58B-014183-050	1
	Screw Shaft 6"	62B-030904-001	1
	Screw Shaft 12" A Option	62B-030904-002	1
11	Scre Shaft 12" B Option	62B-030904-003	1
	Screw Shaft 12" C & D Options	62B-030904-004	1
	Screw Shaft 18"	62B-030904-005	1
	Screw Shaft 24"	62B-030904-006	1
12	Key	58B-016181-009	1
13	Flat Head Screw #632x3/8"	54A-015024-038	3
14	Wear Plate	61B-015922-001	1
15	Gear; Drive Screw	61B-025576-001	1
16	Spacer; Drive Screw	61A-015923-002	1
17	Set Screw #10 - 24x1/4"	54A-035808-025	1
18	Retaining Ring	58B-014186-075	1

Parts Identification

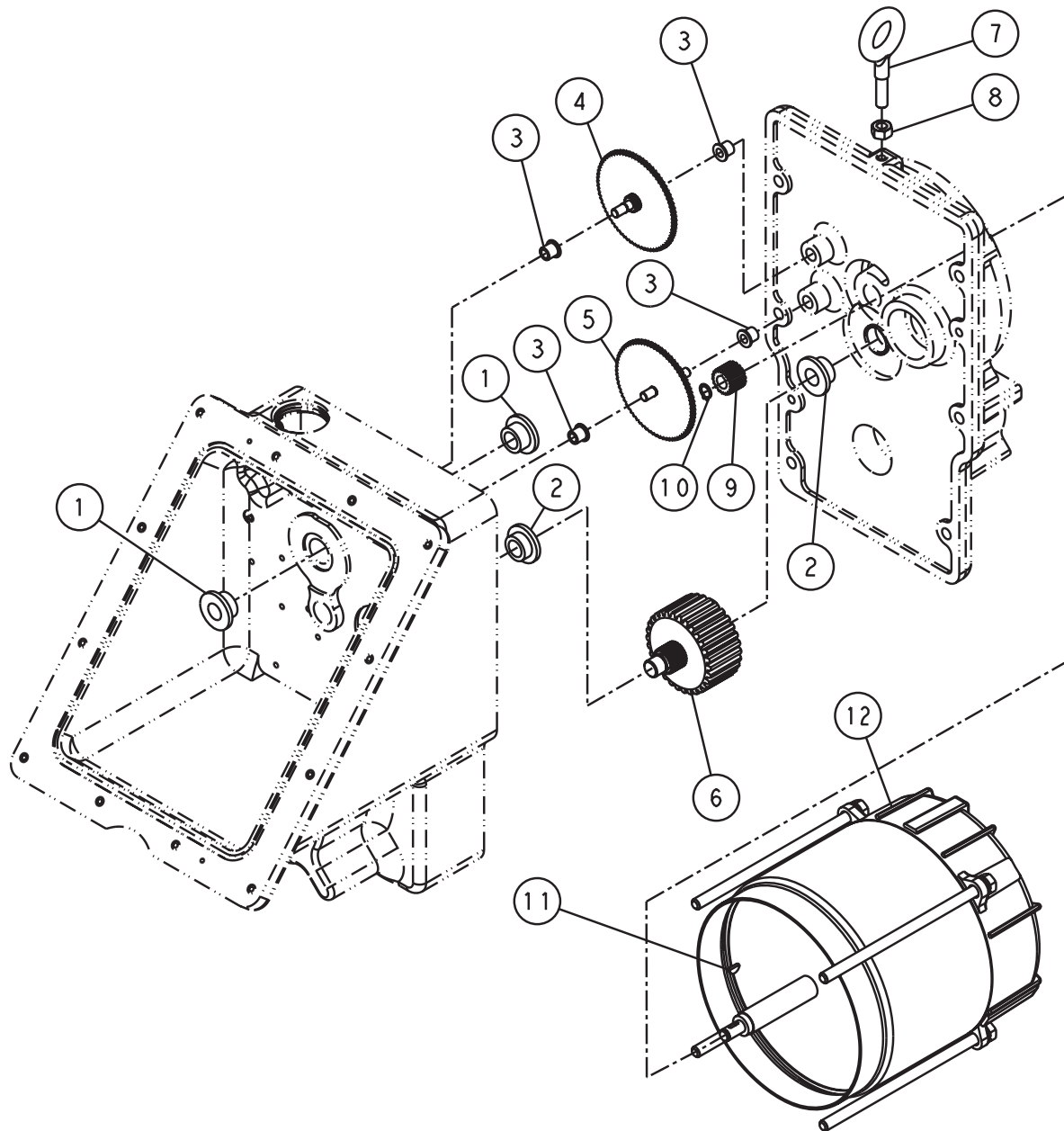

ITEM NO.	DESCRIPTION	PART NUMBER	QTY.
1	Bushing	18B-SP1988-024	2
2	Bushing	18B-SP1988-025	2
3	Bushing	18B-SP1988-006	4
4	2nd Stage F.B. Gear Assembly 6"	65A-024172-003	1
	2nd Stage F.B. Gear Assembly 12" A; B; C & D	65A-024172-001	1
	2nd Stage F.B. Gear Assembly 18" & 24"	65A-024172-002	1
5	1st Stage F.B. Gear Assembly	65A-009938-001	1
6	Power Idler Gear Assembly	65A-014927-001	1
7	Eye Bolt	58B-024244-002	1
8	Nut 3/8 - 16	55A-015088-001	1
9	Pinion	61A-025569-001	1
10	Ret. Ring	58B-014183-037	1
11	Key	58B-016181-006	1
12	Motor	Consult Factory	1

Parts Identification

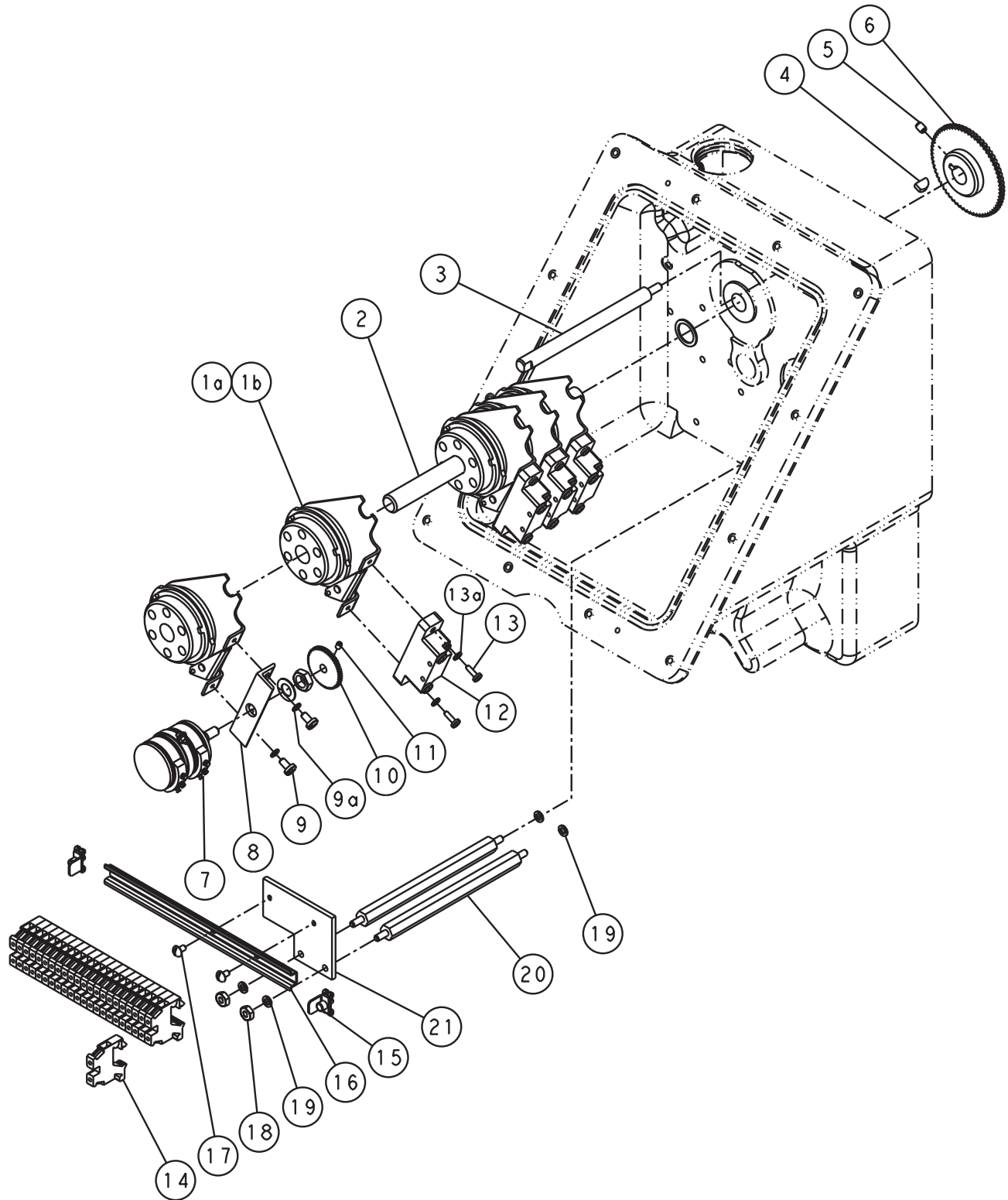

Parts Identification

ITEM NO.	DESCRIPTION	PART NUMBER	QTY.
1A	Cam Adaptor Assembly	68C-021664-001	1
1B	Switch Actuating Assembly AC Units	68B-021658-001	1
2	Switch Shaft; 6 Switches	62B-024188-003	1
3	Anchor Shaft; 6 Switches	62A-021667-004	1
4	Woodruff Key	61A-033186-001	1
5	Set Screw # 10 - 24x1/4"	54A-015047-025	2
6	Gear; Limit Switch Assembly 6"	16A-030911-001	1
	Gear; Limit Switch Assy. 12 A; B; C & D	16A-024171-001	1
	Gear; Limit Switch Assy. 18&24"	16A-030912-001	1
7	1K Potentiometer	34B-034915-001	1
	1K/1K Potentiometer	34B-034916-001	1
8	Potentiometer Mounting Bracket	61A-033462-001	1
9	Screw; 6 - 32 x 1/4"	54A-015023-025	2
	Lock Washer	56A-015180-002	2
10	Gear; Potentiometer	16B-003811-227	1
11	Set Screw 8 - 32x3/16	54A-015037-019	2
12	Switch; AC Units	46A-010017-001	1
13	Screw 6 - 32x1/2"	54A-015023-050	2
	Lock Washer	56A-015180-002	2
14	Terminal Block	43A-038449-001	As Req'd.
15	Clamp	43A-038446-001	2
16	Rail; Terminal Blocks	61A-038450-001	1
17	Screw 8 - 32 x 1/4"	54A-015033-025	2
18	Nut 8 - 32	55A-015038-001	2
19	Lock Washer	56A-015190-002	4
20	Stand-Off	43A-032935-006	2
21	Terminal Mounting Bracket	61A-030942-001	1



Parts Identification

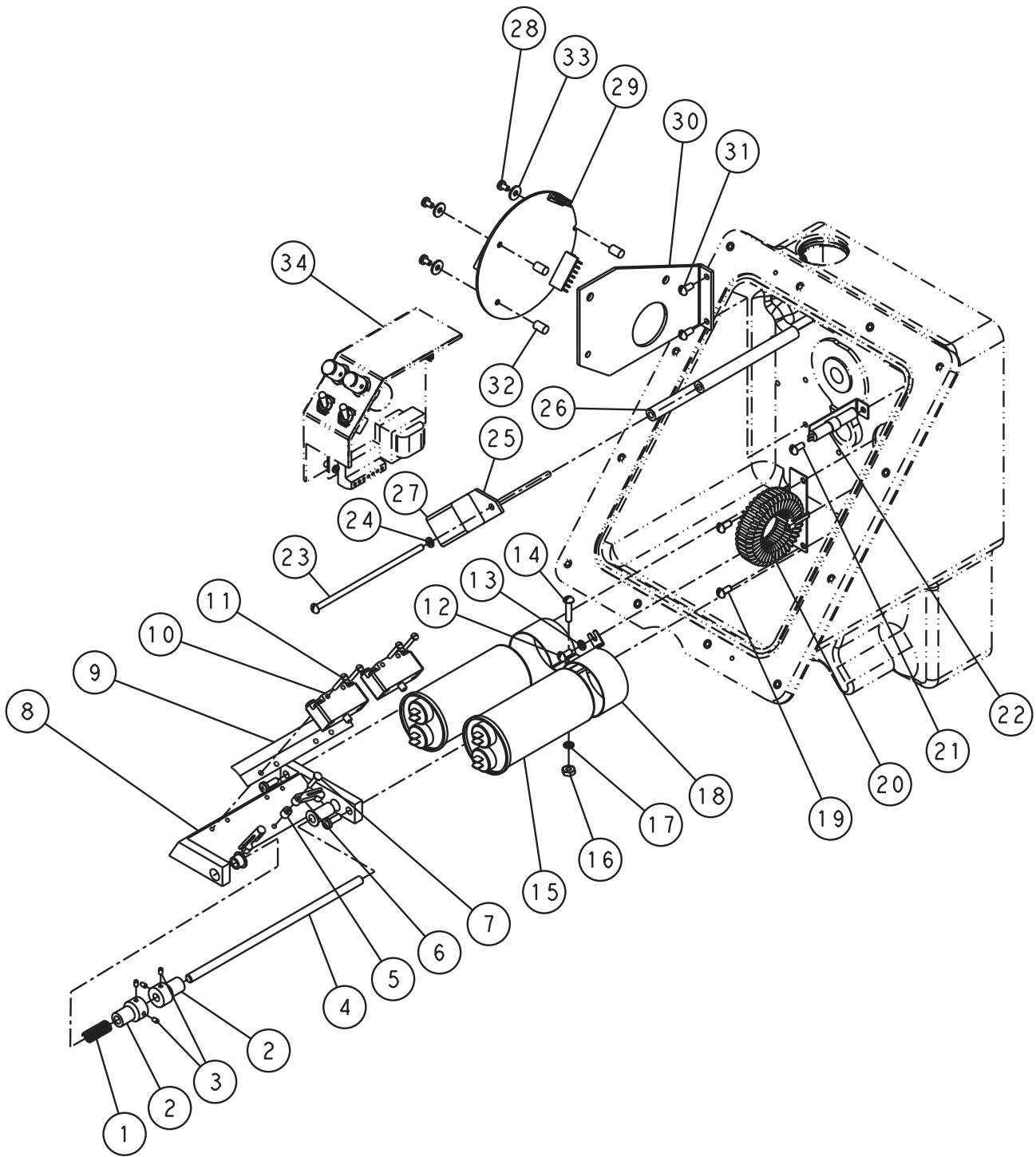

Parts Identification

ITEM NO.	DESCRIPTION	PART NUMBER	QTY.
1	Spring	20A-012010-001	1
2	Collar	61A-013746-001	2
3	Set Screw 10-24 x 3/16	54A-015047-019	4
4	Shaft	62A-016133-001	1
5	Spacer	61A-010031-001	2
6	Switch Activater	14A-009192-001	2
7	Rivet	58B-024244-080	2
8	Frame	60B-016247-001	1
9	Insulater	32A-013376-001	1
10	Switch	46A-010016-003	2
11	Screw #6-32 x 1"	54A-015023-100	4
12	Screw #8-32 x 3/8"	58B-024244-338	2
13	Lockwasher	56A-015190-002	2
14	Screw #8-32 x 5/8"	54A-015033-063	1
15	Capacitor 50UF	24B-029812-019	2
16	#8-32 Nut	55A-015038-001	1
17	Lockwasher	56A-015190-002	1
18	Bracket	13A-036108-001	2
19	Screw #8-32 x 5/16"	54A-015033-031	2
20	Inductor	68B-024980-001	1
21	Screw #8-32 x 5/16"	54A-015033-031	1
22	Heater 120 VAC	74A-016946-001	1
	Heater 240 VAC	74A-016946-002	1
23	Screw #8-32 x 4 1/2"	54A-015033-450	2
24	Lockwasher	56A-015190-002	2
25	Mounting Plate	61A-029137-001	1
26	Spacer	61B-SP1324-154	2
27	ST-4130 Transmitter	70A-019948-001	1
28	Screw #6-32 x 1/2"	54A-015023-050	3
29	AD-8140 Servo Amp. (Optional)	68C-041180-001	1
30	Bracket	61C-036142-001	1
31	Screw #8-32 x 3/8"	58B-024244-338	2
32	Spacer	61B-SP1324-190	3
33	Fibre Washer	56B-005479-002	3
34	EC-10870 Amplifier (Optional)	70C-039465-001	1



Parts Identification

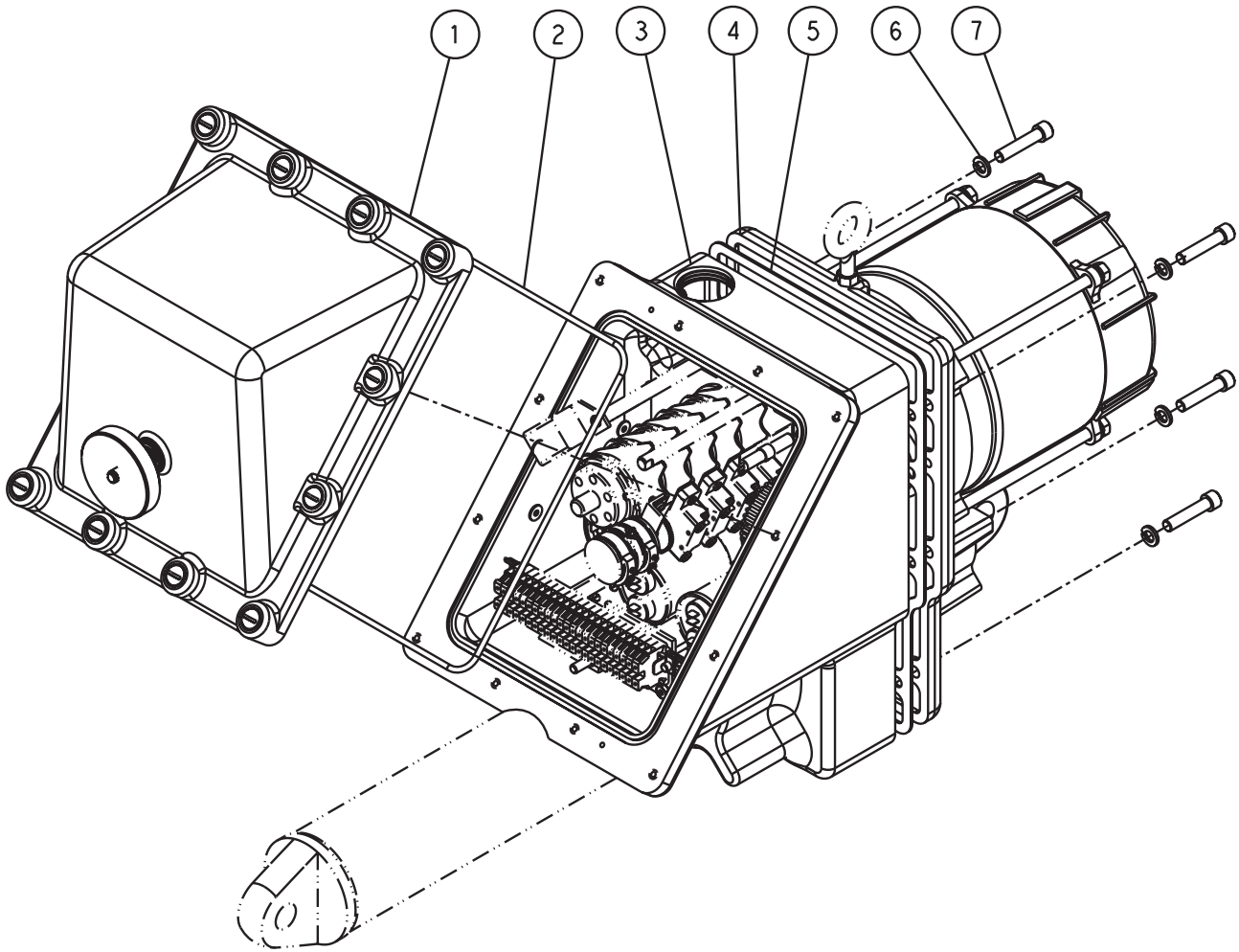

ITEM NO.	DESCRIPTION	PART NUMBER	QTY.
1	Electrical Cover	60C-030892-001	1
2	O-Ring	74A-035940-001	1
3	Feedback Housing	Consult Factory	1
4	Motor Housing	Consult Factory	1
5	Gasket	13C-030909-001	1
6	Lockwasher 5/16"	56A-015221-001	6
7	Bolt 5/16 - 18 x 1 1/2"	54A-015070-150	6
8	Handcrank Shaft	62A-024163-002	1
9	Key	61B-010954-110	1
10	Dowel Pin	57A-015206-075	1

Major Dimensions

THIS PRINT CERTIFIED TO BE CORRECT
 CUSTOMER: BARCOCK & WILCOX
 P.O. # BAX040064
 JORDAN# 74071-1&2 DATE: 5/8/06
 TAG: 4SG-MOT-1A1 THRU 1A5
 4SG-MOT-1B1 THRU 1B5
 4SG-MOT-1C1 THRU 1C5
 4SG-MOT-1D1 THRU 1D5
 4SG-MOT-1E1 THRU 1E5
 4SG-MOT-860 THRU 863

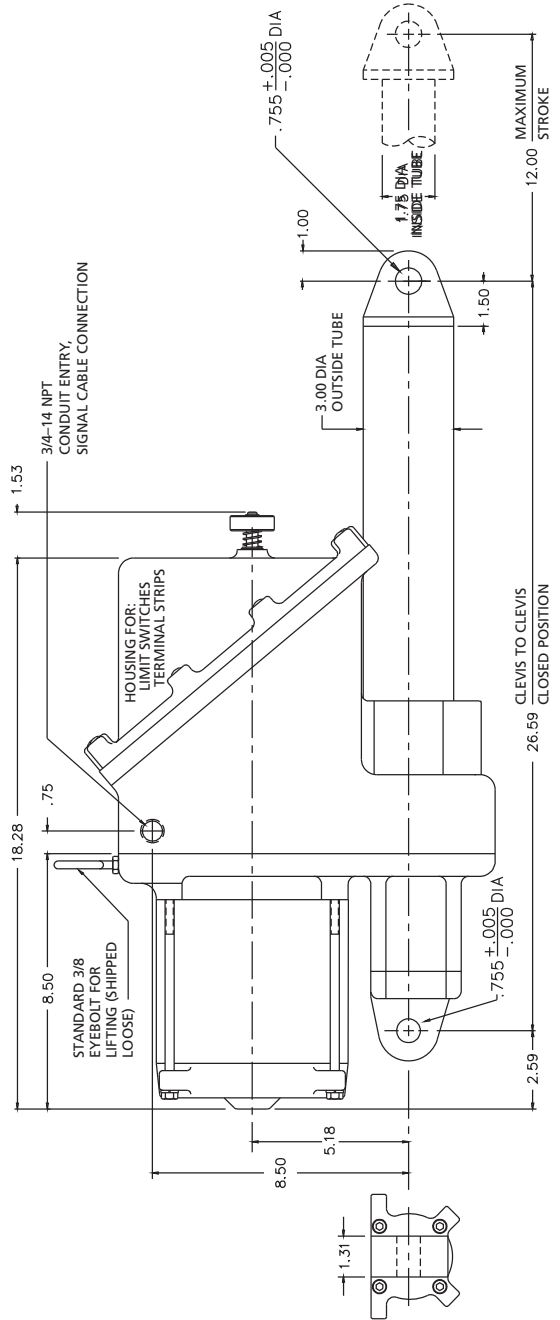
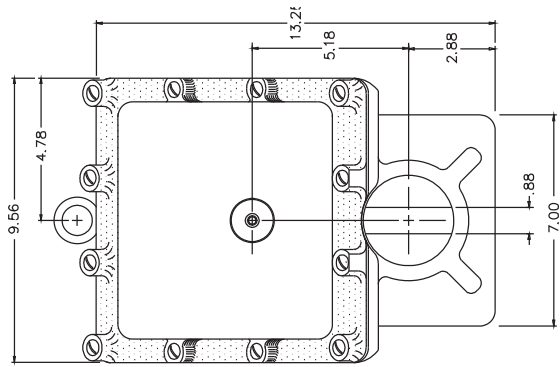
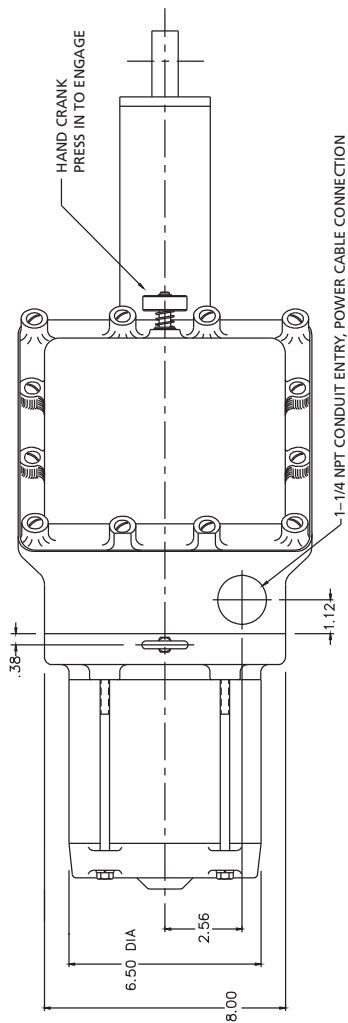

Hazardous Locations

NOTE: This section covers actuator installation in Hazardous locations. All guidelines must be followed except when specifically noted.

WARNING - SHOCK HAZARD

- EXPLOSION PROOF and DUST-IGNITION PROOF ACTUATORS are not explosion proof or dust-ignitionproof until final installation is complete. Hazardous location enclosures must be installed in accordance with The National Electric Code requirements as well as state and local codes.
- Actuators must be installed in accordance with IEC/EN 60079-14, Electrical apparatus for explosive atmospheres, Part 14. Electrical installations in hazardous areas (other than mines).
- Do not open while energized.
- Do not open while in flammable gas or dust atmosphere.

ENVIRONMENT

Standard Voltages:

120/240 VAC 6/3 A @ 60 Hz
7.6/3.8 A @ 50 Hz Single Phase





Temperature Limits:

-22 to 150 °F (-30 to 60 °C)
-4 to 140 °F (-20 to 60 °C)

IDENTIFICATION LABEL

An identification label is attached to each actuator. When ordering parts, requesting information or service assistance, please provide all of the label information.

ATEX LABEL

Rotork Process Controls <small>5807 WEST DOUGLAS AVENUE MILWAUKEE, WISCONSIN 53218 (414) 461-9200 Fax: (414) 461-1024 E-Mail: rpdinfo@rotork.com</small>		  1725 II2GD
MODEL: LA-2500		WARNINGS: DO NOT OPEN WHEN AN EXPLOSIVE ATMOSPHERE IS PRESENT CABLE ENTRIES CAN REACH 105°C IN AN AMBIENT OF 60°C ALL CABLE ENTRIES TAPPED 1/2" NPT 
SERIAL: 1234E03	<small>LAST TWO DIGITS OF SERIAL NUMBER DENOTE YEAR OF MANUFACTURE</small>	
V: Hz: PH: A:		
WIRING DIA:		
CUSTOMER P/N:		
CERTIFICATE No: Sira 09ATEX1263X		
RPC P/N: Gb		
Ex II 2GD EEx dIIB T4 Ta -20 to +60 °C		<small>PIN 53B-041591</small>
		

HAZARDOUS RATINGS

ATEX  II 2 GD

Ex dIIB T4 Gb T4
(Ta = -20 to 60 °C)

Actuator Characteristics relating to the hazardous environment:

- The actuator was designed in accordance to 94/9/EC
- The actuators are manufactured from aluminium alloy with stainless steel shafts and oilite bronze bushes and carbon steel fasteners.
- The lid securing screws must be steel quenched and tempered SAE grade 8 or optional stainless steel. Stainless steel property class A4-80.
- All external seals are manufactured from Nitrile which is suitable for use in an ambient temperature range of -20 to 60 °C.
- The user must insure that the operating environment and any materials surrounding the actuator cannot lead to a reduction in the safe use of, or the protection afforded by, the actuator.
- Where appropriate, the user must ensure the actuator is suitably protected against its operating environment.

Hazardous Locations

INSTALLATION

Installation should be carried out by a competent person in accordance with IEC/EN 60079-14, Electrical apparatus for explosive atmospheres, part 14 (electrical installations in hazardous areas other than mines).

- Where cables enter the unit, suitably certified and appropriate cable glands or conduit entries must be used.
- All unused cable entry points must be sealed with a suitable certified and appropriate blanking element.
- Must use certified cable or conduit entries. Also the blanking of unused cable entry points must be done with suitable certified blanking elements.
- The lid securing screws must be steel quenched and tempered SAE grade 8 or optional stainless steel. Stainless steel property class A4-80.

CE Compliant Actuators

LA-2500 series actuators ordered as CE actuators will be supplied with a Document of Incorporation (DOI). The DOI indicates compliance to CE and that the actuator can be used in equipment that will be CE certified based on the application. There are requirements that the installer must meet to enable system compliance, and may vary based on the application.

1. Installation requirements described in this manual are met.
2. Insure that the external motor temperature does not exceed the temperature limits of the EN standard governing the installation.
3. Insure that the internal actuator temperature does not exceed 248 °F (120 °C).
4. Insure that EMC requirements of the system based on the CE standard governing the installation are met.
5. **The user must complete a risk assessment and implement whatever measures are required to ensure that the resultant system complies with all applicable legislation.**

MAINTENANCE

- Rotork Controls actuators are maintenance free. It is recommended that you remove the cover and visually inspect the actuator on an annual basis.
- Maintenance must be performed only by qualified personnel. Voltages hazardous to your health are applied to these actuators. De-energize all sources of power before removing actuator cover. Failure to follow these precautions may result in serious injury or death. ATEX approved actuators must be repaired and overhauled in accordance with IEC/EN 60079-19, Electrical apparatus for explosive atmospheres, Part 19. Repair and overhaul for apparatus used in explosive atmospheres (other than mines).
- Lubrication: The gearing is permanently lubricated. Re-lubrication is only required during repairs to the power gearing. The bronze bushings are lubricated with a few drops of SAE-10 or 20 NON-DETERGENT oil. Re-lubricate when repairs are made.



Hazardous Locations

In accordance with Clause 5.1 of IEC EN60079-1, the critical dimensions of the flame paths are:

	MAXIMUM GAP		MINIMUM GAP	
	inches	mm	inches	mm
Hand Crank Casting/Shaft	-0.0005	-0.01	-0.0025	-0.06
Hand Crank Shaft/Bushing	0.0040	0.10	0.0020	0.05
Feedback Shaft Casting/Bushing (Single Turn)	-0.0010	-0.03	-0.0030	-0.08
Feedback Shaft Bushing/Shaft (Single Turn)	0.0040	0.10	0.0010	0.03
Lower Hand Crank Sleeve/Bushing	-0.0005	-0.01	-0.0025	-0.06
Lower Hand Crank Sleeve/Casting	-0.0005	-0.01	-0.0025	-0.06
Lower Hand Crank Bushing/Shaft	0.0075	0.19	0.0020	0.05
Thrust Shaft Casting/Bushing	0.0020	0.05	0.0000	0
Thrust Shaft Bushing/Shaft	0.0030	0.08	0.0010	0.03
Motor Shaft Motor/Casting	0.0059	0.15	0.0047	0.12
Bell Housing Motor/Casting	0.0030	0.08	0.0000	0
Feedback-Motor Casting Mtr Casting/Feedback Casting	0.0030	0.08	0.0010	0.03
Upper O-ring Seal Seal/Casting Edge	0.0000	0.00	0.0000	0
Lower O-ring Seal Seal/Machined Diameter	0.0000	0.00	0.0000	0
Bell Housing Bell Housing/Motor Frame	0.0030	0.08	-0.0010	-0.03
Feedback Shaft Casting/Bushing (10 Turn)	-0.0010	-0.03	-0.0030	-0.08
Feedback Shaft Bushing/Shaft (10 Turn)	0.0040	0.10	0.0010	0.03

Notes



Notes



Notes



rotork®

Redefining Flow Control

www.rotork.com

A full listing of our worldwide sales and service network is available on our website.

Rotork plc
Brassmill Lane, Bath, UK
tel +44 (0)1225 733200
fax +44 (0)1225 333467
email mail@rotork.com

USA
Rotork Controls
tel +1 (585) 247 2304
fax +1 (585) 247 2308
email info@rotork.com

Scan with your smart phone
for more information on
this product range



PUB045-004-00
Issue 09/15

As part of a process of on-going product development, Rotork reserves the right to amend and change specifications without prior notice. Published data may be subject to change. For the very latest version release, visit our website at www.rotork.com

The name Rotork is a registered trademark. Rotork recognises all registered trademarks. Published and produced in the UK by Rotork Controls Limited. POWDG1015